

WITH
CUMULATIVE INDEX

Rudolf F. Graf
&
William Sheets

Encyclopedia of
**ELECTRONIC
CIRCUITS**

Volume 6

TAB

The
Electronics
Authority

Encyclopedia of

ELECTRONIC CIRCUITS

Volume 6

To Russell
May you always be as self-confident as you are today.

Patent notice

Purchasers and other users of this book are advised that several projects described herein could be proprietary devices covered by letters patent owned or applied for. Their inclusion in this book does not, by implication or otherwise, grant any license under such patents or patent rights for commercial use. No one participating in the preparation or publication of this book assumes responsibility for any liability resulting from unlicensed use of information contained herein.

Encyclopedia of

ELECTRONIC CIRCUITS

Volume 6

Rudolf F. Graf
&
William Sheets

McGraw-Hill

New York San Francisco Washington, D.C. Auckland Bogotá
Caracas Lisbon London Madrid Mexico City Milan
Montreal New Delhi San Juan Singapore
Sydney Tokyo Toronto



©1996 by **Rudolf F. Graf & William Sheets**.
Published by The McGraw-Hill Companies, Inc.

Printed in the United States of America. All rights reserved. The publisher and the authors take no responsibility for the use of any of the materials or methods described in this book, nor for the products thereof.

pbk 1 2 3 4 5 6 7 8 9 0 FGR/FGR 9 0 0 9 8 7 6

hc 1 2 3 4 5 6 7 8 9 0 FGR/FGR 9 0 0 9 8 7 6

Product or brand names used in this book may be trade names or trademarks. Where we believe that there may be proprietary claims to such trade names or trademarks, the name has been used with an initial capital or it has been capitalized in the style used by the name claimant. Regardless of the capitalization used, all such names have been used in an editorial manner without any intent to convey endorsement of or other affiliation with the name claimant. Neither the author nor the publisher intends to express any judgment as to the validity or legal status of any such proprietary claims.

Library of Congress Cataloging-in-Publication Data **(Revised for vol. 6)**

Graf, Rudolf F.

The encyclopedia of electronics circuits

Authors for v. 6- : Rudolf F. Graf & William
Sheets.

Includes bibliographical references and indexes.

1. Electronic circuits—Encyclopedias. I. Sheets,

William. II. Title

TK7867G66 .1985 621.3815 .84-26772

ISBN 0-8306-0938-5 (v. 1)

ISBN 0-8306-1938-0 (pbk. : v. 1)

ISBN 0-8306-3138-0 (pbk. : v. 2)

ISBN 0-8306-3138-0 (v. 2)

ISBN 0-8306-3348-0 (pbk. : v. 3)

ISBN 0-8306-7348-2 (v. 3)

ISBN 0-8306-3895-4 (pbk. : v. 4)

ISBN 0-8306-3896-2 (v. 4)

ISBN 0-07-011077-8 (pbk. : v. 5)

ISBN 0-07-011076-X (v. 5)

ISBN 0-07-011275-4 (v. 6)

ISBN 0-07-011276-2 (pbk. : v. 6)

McGraw-Hill books are available at special quantity discounts to use as premiums and sales promotions, or for use in corporate training programs. For more information, please write to the Director of Special Sales, McGraw-Hill, 11 West 19th Street, New York, NY 10011. Or contact your local bookstore.

Acquisitions editor: Roland S. Phelps

Editorial team: Lori Flaherty, Executive Editor

Andrew Yoder, Book Editor

Joann Woy, Indexer

Production team: Katherine G. Brown, Director

Rose McFarland, Desktop Operator

Nancy Mickley, Proofreading

Design team: Jaclyn J. Boone, Designer

Katherine Lukaszewicz, Associate Designer

EL1
0112762

Contents

Introduction	ix
1 AGC and ALC Circuits	1
2 Air-Flow Circuits	4
3 Alarm and Security Circuits	7
4 Amateur Circuits	17
5 Amateur Television (ATV) Circuits	33
6 Amplifier Circuits	46
7 A/D Converter Circuits	58
8 Antenna Circuits	61
9 Attenuator Circuits	68
10 Audio Signal Amplifier Circuits	71
11 Audio Power Amplifier Circuits	83
12 Automotive Circuits	94
13 Battery Charger Circuits	105
14 Battery Monitor Circuits	114
15 Bridge Circuits	121
16 Buffer Circuits	124
17 Clock Circuits	129

18	Computer-Related Circuits	132
19	Continuity Circuits	142
20	Converter Circuits	146
21	Crystal Oscillator Circuits	156
22	Current Source and Sink Circuits	161
23	dc/dc Converter Circuits	164
24	Decoder Circuits	168
25	Delay Circuits	172
26	Detector Circuits	174
27	Differential Amplifier Circuits	185
28	Display Circuits	188
29	Driver Circuits	196
30	Electronic Lock Circuits	203
31	Fiber-Optics Circuits	206
32	Filter Circuits	208
33	Flasher Circuits and Blinkers	223
34	Flip-Flop Circuits	228
35	Frequency-to-Voltage Converter Circuits	231
36	Function Generator Circuits	234
37	Game Circuits	244
38	Humidity Sensor Circuits	255
39	Indicator Circuits	258
40	Infrared Circuits	261
41	Instrumentation Amplifier Circuits	272
42	Integrator Circuits	278
43	Interface Circuits	280
44	Inverter Circuits	282
45	Ion Circuits	286
46	Laser Circuits	289
47	Light-Controlled Circuits	297

48	Logic Circuits	313
49	Mathematical Circuits	317
50	Measuring and Test Circuits	327
51	Metronome Circuits	364
52	Miscellaneous Treasures	367
53	Mixer Circuits	392
54	Model and Hobby Circuits	394
55	Modulator Circuits	397
56	Morse-Code Circuits	404
57	Motor-Control Circuits	410
58	Multivibrator Circuits	417
59	Noise Circuits	420
60	Operational Amplifier Circuits	425
61	Oscillators (Audio)	432
62	Oscillators (Miscellaneous)	441
63	Oscillators (RF)	448
64	Oscilloscope Circuits	460
65	Photography-Related Circuits	465
66	Piezo Circuits	469
67	Power Line Circuits	471
68	Power Supply Circuits	476
69	Power Supply Circuits (High Voltage)	499
70	Power Supply Circuits (Multiple Output)	506
71	Power Supply Circuits (Variable Output)	514
72	Probe Circuits	520
73	Protection Circuits	525
74	Radar Detector Circuits	527
75	Radiation Detector Circuits	530
76	Receiving Circuits	534
77	Reference Circuits	559

78	Regulator Circuits	561
79	Relay Circuits	568
80	Sample-and-Hold Circuits	573
81	Sawtooth Generator Circuits	575
82	Scanner Circuits	578
83	Siren, Warbler and Wailer Circuits	581
84	Sound-Effects Circuits	585
85	Square-Wave Generator Circuits	593
86	Staircase Generator Circuits	595
87	Stepper Motor Circuits	600
88	Switching Circuits	603
89	Sync Circuits	615
90	Telephone-Related Circuits	619
91	Temperature-Related Circuits	629
92	Timer Circuits	648
93	Tone Control Circuits	651
94	Touch/Proximity Control Circuits	654
95	Tracer Circuits	658
96	Transmitter and Transceiver Circuits	660
97	Ultrasonic Circuits	666
98	Video Circuits	671
99	Voltage-Controlled Amplifier Circuits	684
100	Voltage-Controlled Oscillator Circuits	686
101	Voltage-Measuring Circuits	688
102	Waveform Generator Circuits	696
103	Waveguide Circuits	703
104	White-Noise Generator Circuits	705
	Sources	707
	Index	736
	About the Authors	789

Introduction

The enthusiastic reception of the first five volumes of *The Encyclopedia of Electronic Circuits* prompted the authors to produce this volume—the sixth in the popular series.

Taken together, the six volumes contain approximately 6000 circuits—by far the largest and broadest collection of practical electronic circuits available anywhere.

As in the other volumes, the 1000+ circuits presented here are arranged alphabetically, by category. All circuits in this volume, as well as those from the previous five volumes, are included in the index, which now has approximately 6000 entries.

We express sincere appreciation to the many electronic industry sources and publishers who graciously allowed us to utilize some of their materials. Their cooperation is gratefully acknowledged.

Once again, it gives us great pleasure to extend our sincerest thanks to Loretta Gonsalves-Battiste, a fine lady whose skill at the computer and willingness to work long and hard made on-time delivery of the manuscript for this book possible.

Rudolf F. Graf & William Sheets
September 1995

1

AGC and ALC Circuits

The sources of the following circuits are contained in the Sources section, which begins on page 707. The figure number in the box of each circuit correlates to the entry in the Sources section.

AGC Audio Preamp
3-MHz Low-Noise AGC System
IF AGC Network
Audio Leveler

AGC AUDIO PREAMP

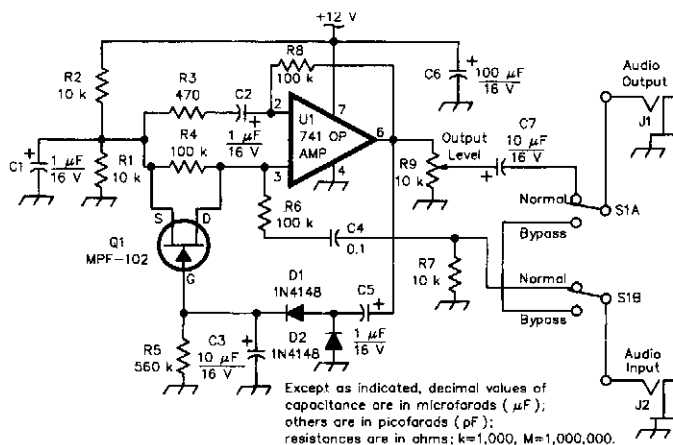

QST

Fig. 1-1

The circuit uses an easily obtained 741 op amp set for an internal gain of about 200. A portion of the op amp's output signal is rectified by the 1N4148 diodes, then filtered and fed to the gate of the FET input shunting circuit. As the output rises, more and more input shunting takes place. That is, more of the input signal is bypassed, effectively keeping the output level constant.

The circuit offers a 100:1 limiting action. The input level can change over a 100:1 ratio with little or no effect on the output level. The output level itself can be set from less than unity all the way up to nearly the gain of the amplifier, making the circuit usable in other applications as well.

3-MHz LOW-NOISE AGC SYSTEM

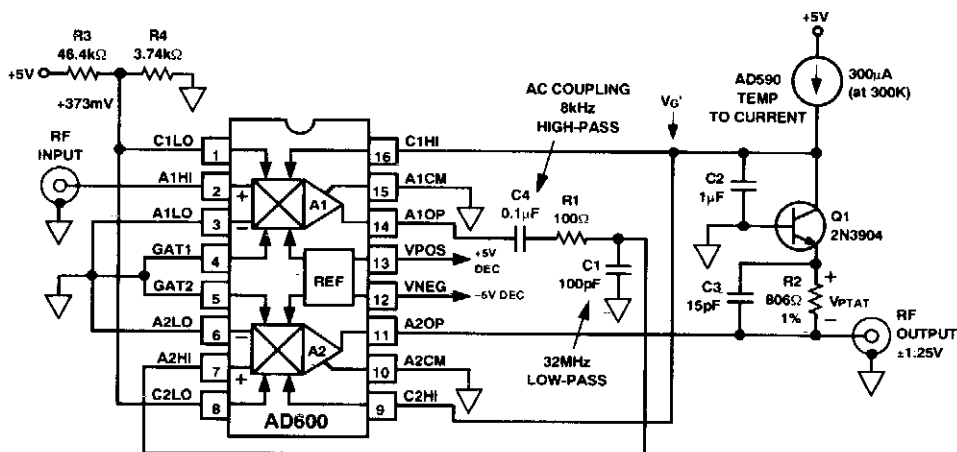

ANALOG DIALOG

Fig. 1-2

The AD600 dual voltage-controlled amplifier in this circuit provides a 3-MHz AGC system with 80-dB range.

IF AGC NETWORK

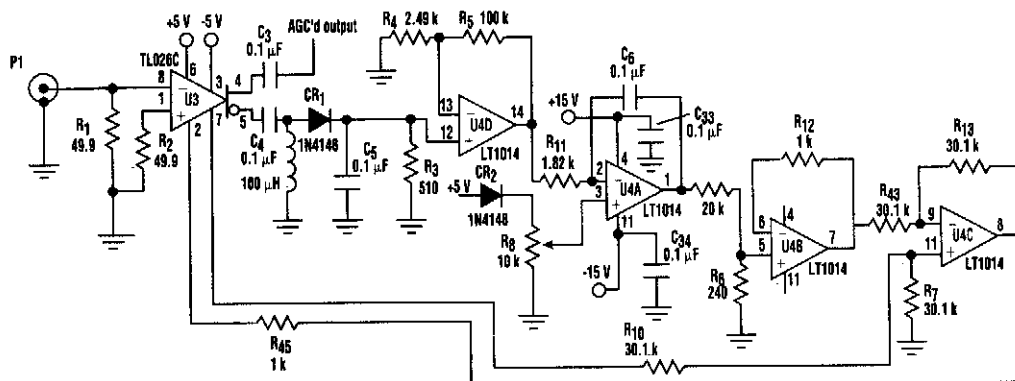

ELECTRONIC DESIGN

Fig. 1-3

A simple IF AGC circuit that features wide dynamic range and excellent linearity can be achieved with two chips: TI's TL026C voltage-controlled amplifier IC and Linear Technology's LT1014 (or any other similar basic quad op amp).

AUDIO LEVELER

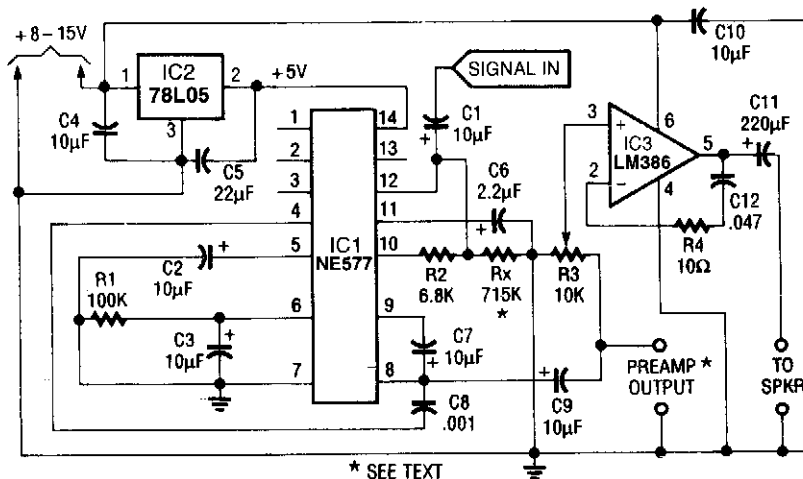

1994 EXPERIMENTERS HANDBOOK

Fig. 1-4

A low power programmable compandor chip, the Signetics NE577 IC is used. Incoming audio is compressed, rectified and conditioned so that the input signal level always remains about the noise level. The compressor is an ALC circuit that outputs a constant level and the expander part of the IC is not used.

2

Air-Flow Circuits

The sources of the following circuits are contained in the Sources section, which begins on page 707. The figure number in the box of each circuit correlates to the entry in the Sources section.

Hot-Wire Anemometer
Electronic Anemometer
Air Flow Detector

HOT-WIRE ANEMOMETER

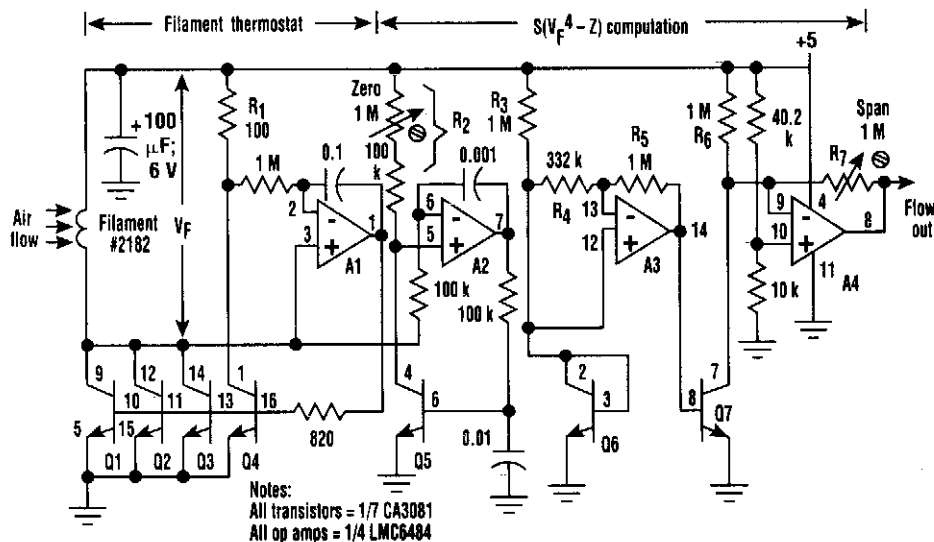

ELECTRONIC DESIGN

Fig. 2-1

An anemometer can be realized by utilizing the inherent transconductance match of transistors in the array, instead of passive series resistances, to control filament current. As a result, as A1 serves the collector current of Q4 and thereby the voltage across R1, it simultaneously adjusts the filament (a 2182-type incandescent lamp denuded of its glass envelope) voltage, V_f . The ratio of the filament to R1 current is stably maintained by the identical temperature and operating points of Q1 through Q4. The net result is that A1 drives the filament temperature to the value that causes filament resistance to equal $R1/3 = 33 \Omega$. This is about double the cold resistance of the filament and therefore, assuming tungsten wire with a 0.0045/degree coefficient of resistance, represents a filament operating temperature of around 230°C. This is hot enough that moderate changes in ambient temperature are unimportant factors in filament power demand, but not so hot as to cause the filament to burn.

Rail-to-rail input amplifier A2 continuously serves the collector current of Q5 to V_f/R_2 , making the V_{bc} of Q5 a logarithmic function of V_f . A3 multiplies this log by 4 and applies the product of Q7. Q7 does the antilog function so that its collector current is proportional to the fourth power of V_f . Thus, by King's law, it's proportional to air speed in the vicinity of the filament. This current is offset and scaled by A4 to produce a voltage output that, thanks to the rail-to-rail output capability of the LMC6484, can range from 0.01 to 4.99 V. Full-scale air speed can be adjusted, using R7, to any value in the range of 1 to 10 meters/s.

ELECTRONIC ANEMOMETER

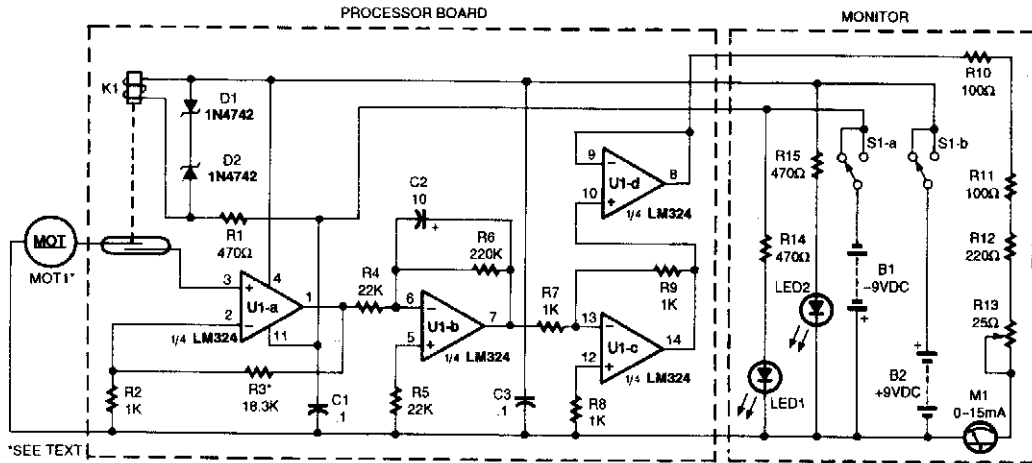

POPULAR ELECTRONICS

Fig. 2-2

A motor used as a generator is used as a transducer to generate a dc voltage that is proportional to wind speed. K1 prevents the transducer voltages from being applied to the circuit if no dc power is present. U1A through U1D is a dc amplifier, integrator, and buffer. This circuit drives the meter M1. The processor board is mounted in a housing along with the generator M1.

AIR FLOW DETECTOR

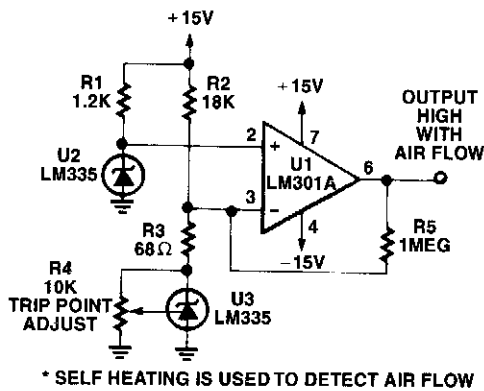

POPULAR ELECTRONICS

Fig. 2-3

The self heating of a semiconductor that is cooled by airflow is used as a sensing method.

3

Alarm and Security Circuits

The sources of the following circuits are contained in the Sources section, which begins on page 707. The figure number in the box of each circuit correlates to the entry in the Sources section.

- Burglar Alarm Circuit
- Auto Security System Transmitter
- Home Security System
- Auto Security System Receiver
- Flashing Brake Light for Motorcycles
- Car Alarm Decoy
- Motorcycle Alarm
- Simple Bike Horn
- Door Ajar Indicator
- Motorcycle Burglar Alarm
- Horn Circuit for Motorcycle Use

BURGLAR ALARM CIRCUIT

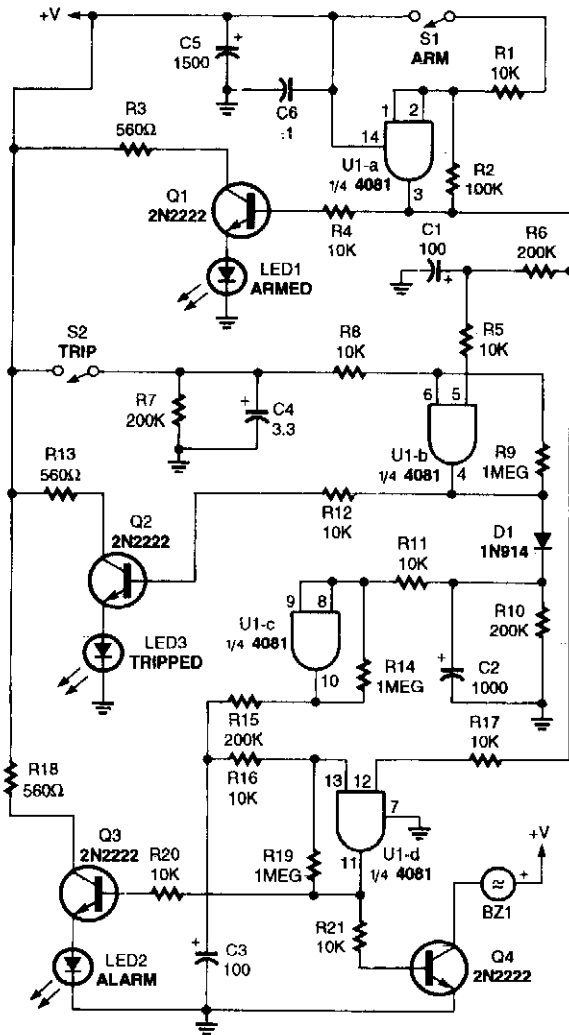

POPULAR ELECTRONICS

Fig. 3-1

This alarm circuit is built around a single 4081 (CMOS) quad AND gate. It offers an exit and entry delay (around automatically reset two minutes after tripping, provided that the trip input is not left high).

The arming switch must go high to arm or low to disarm. After arming, U1-a begins to charge C1 via R6. Around 20 seconds later (after the exit delay), C1 has a sufficient charge to produce a high at the pin-5 input of U1-b. Also, when the circuit is armed, Q1 is turned on to indicate arming, and one input of U1-d is brought high.

After the exit delay times out, if the trip input opens, it causes an output on gate U1-b. Transistor Q1 is turned on, lighting the trip indicator (LED3), C2 instantly charges, and the output of U1-c goes high. At that point, C3 begins charging to provide the entry delay.

After 20 seconds, C3 has sufficient charge to produce a high at pin 13 of U1-d. That forces U1-d's output high, turning Q3 and Q4 on, which activates the alarm indicator (LED2) and sounder (BZ1), respectively. If disarmed after a trip pulse, but before the 20-second, entry delay time out, pin 12 of U1-d goes low, so the gate's output does not go high and the alarm does not sound.

Components C2 and R10 hold U1-c on for around 2 minutes and 20 seconds to provide the two-minute alarm. After C2's charge drops below half of the supply voltage, U1-c's output goes low, awaiting another trip pulse to set it off again.

AUTO SECURITY SYSTEM TRANSMITTER

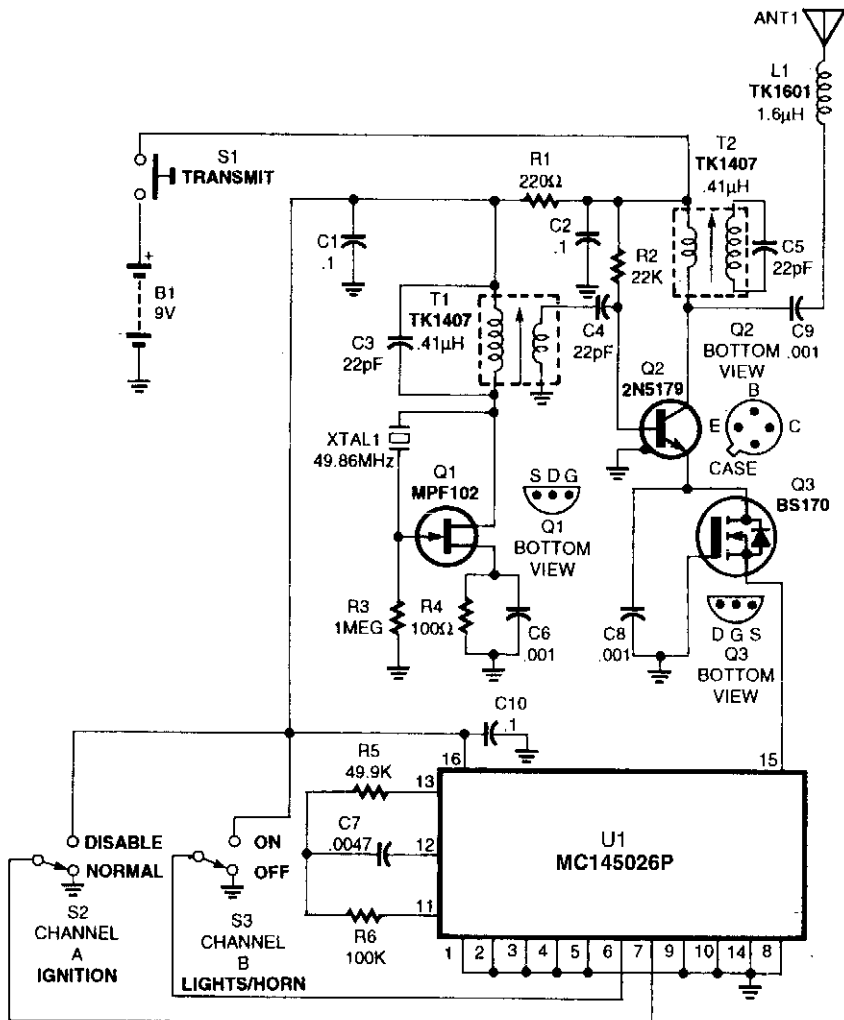

This transmitter operates at 49 MHz and uses an M145026 programmable digital encoder to generate a unique digital code, depending on the positions of S2 and S3, to control ignition and lights or horn. Q1 is the oscillator, Q2 the power amplifier. The antenna is a 36-inch whip or wire antenna.

HOME SECURITY SYSTEM

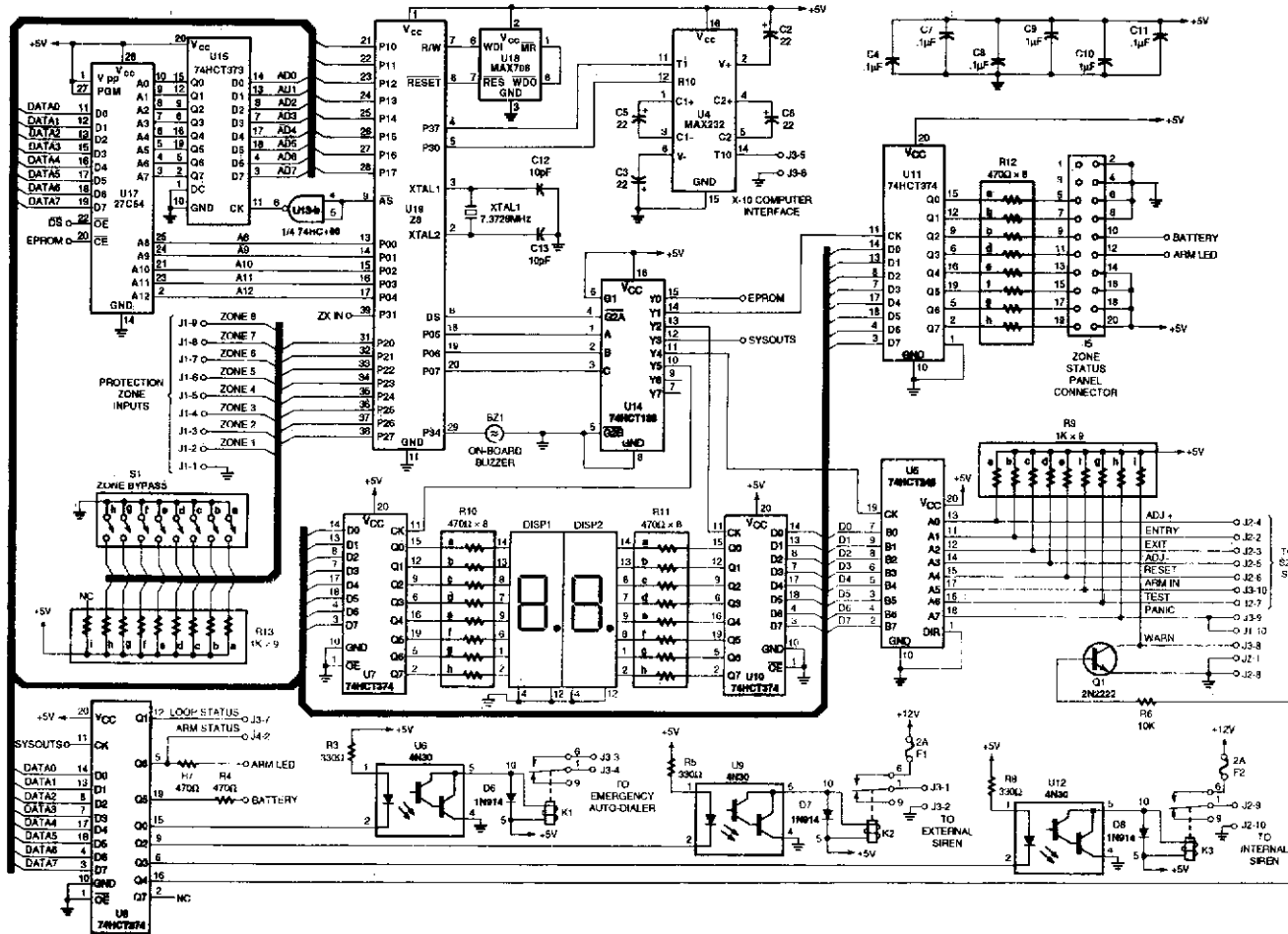

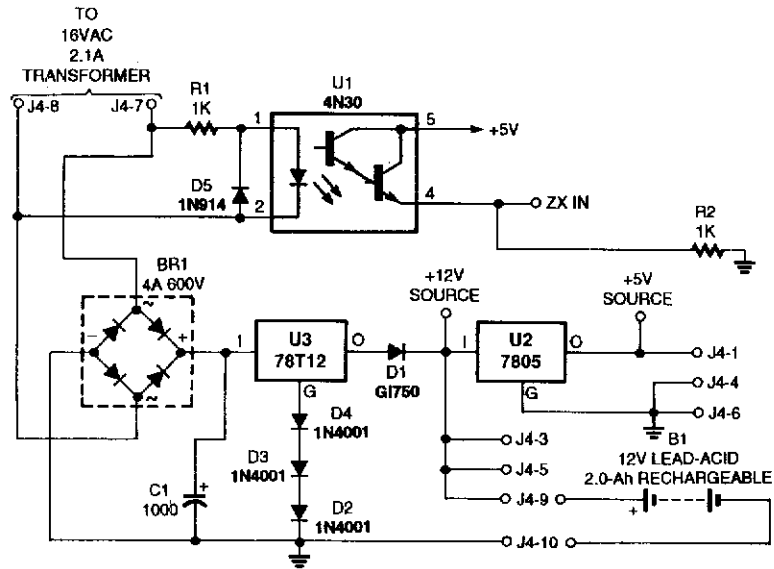

POPULAR ELECTRONICS

Fig. 3-3

At the heart of the main-control unit is U16, Zilog's Z8-8-bit microcontroller, which receives its program instruction from U17, a 27C64 8K x 8 EPROM. The home security system in its most basic form, features eight individual protection zones, adjustable entry and exit delays, a panic switch (for emergency situations), automatic system reset, support for an auto-dialer (which, in case of emergency, dials pre-programmed telephone numbers), it's X-10 compatible (allowing it to control house lights and appliances), has a backup battery (to keep the system on-line during a power failure), and there is also an optional zone-status panel that is used to individually show the condition of each protection zone.

This system's power supply provides 12 Vdc for the sirens and digital keypad, and 5 Vdc for the on-board electronics, while also providing a constant 12-V output that's used to charge the backup-battery.

AUTO SECURITY SYSTEM RECEIVER

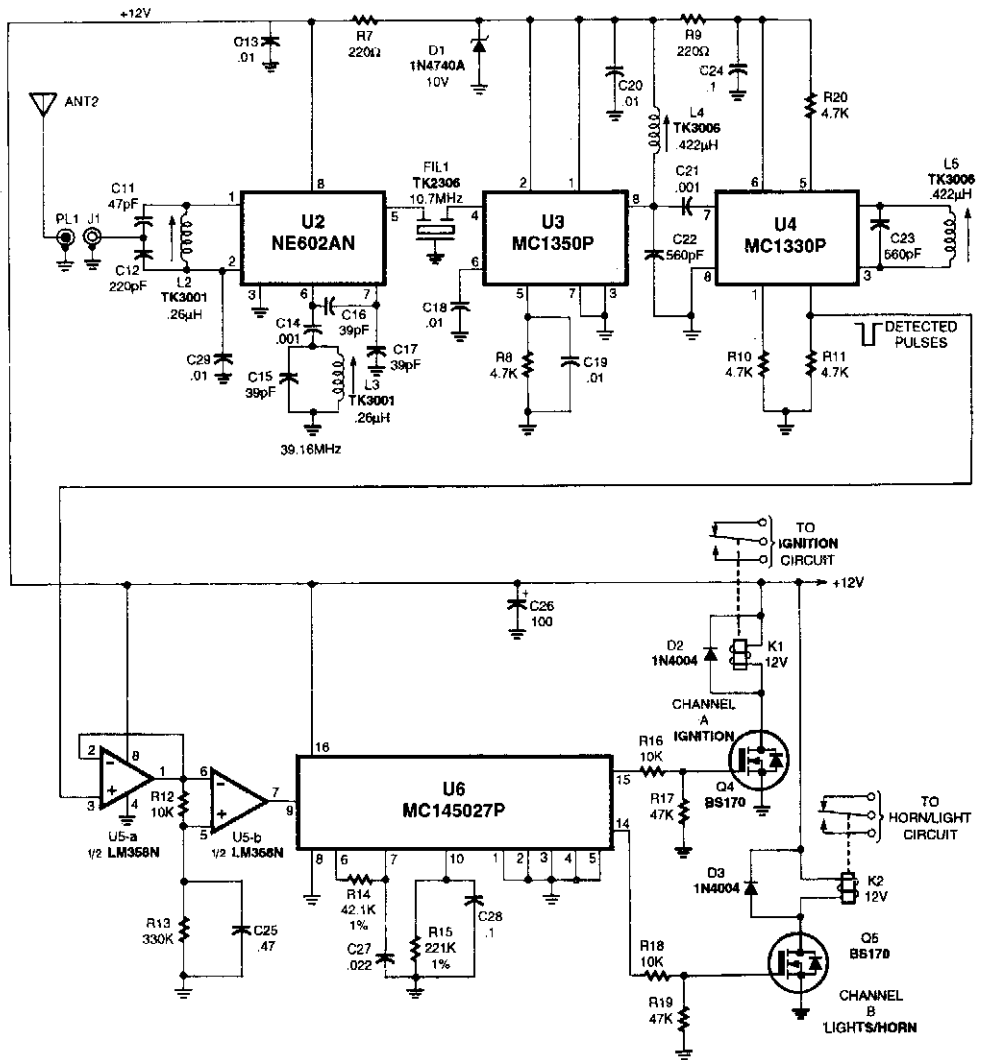

This receiver is a superheterodyne type tuned to 49 MHz. U2 is a mixer, followed by a 10.7-MHz filter and two-stage IF (U3, U4) and detector. The encoded received RF pulse signal from the antenna produces detected pulse from the MC1330P. These pulses are amplified by U5 and fed to decoder IC U6, and MC1450278. Two channels are available at the output, which drives K1 and K2.

FLASHING BRAKE LIGHT FOR MOTORCYCLES

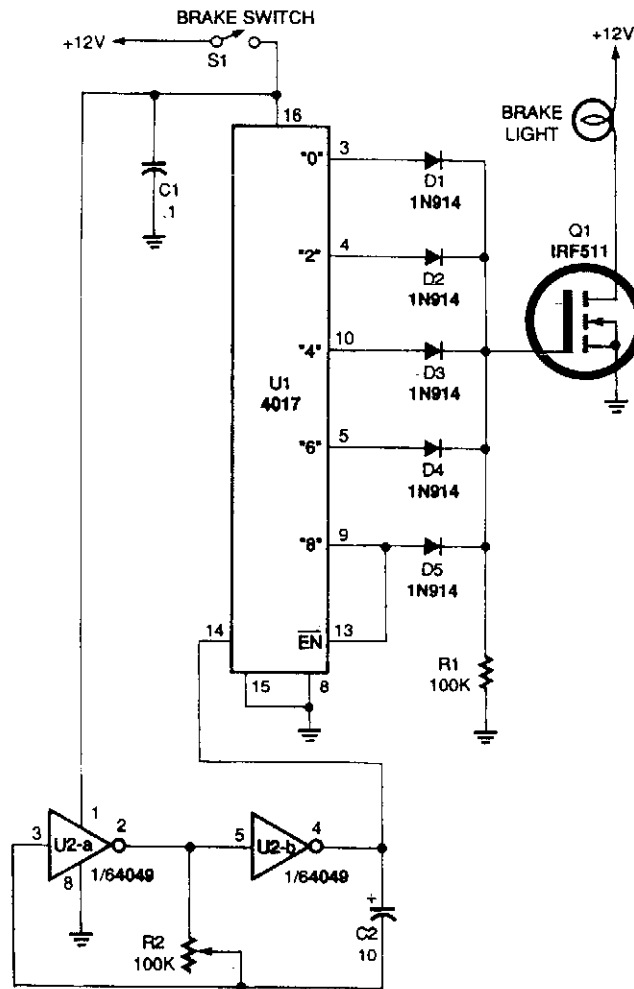

POPULAR ELECTRONICS

Fig. 3-5

When brake-light switch S1 is closed, power is applied to U1 and U2. Two inverters of U2, a 4049 hex inverting buffer, are connected in a low-frequency oscillator circuit that feeds clock pulses into U1, a 4017 decade counter/divider. Outputs 0, 2, 4, 6, and 8 of U1 are coupled to the gate of Q1 through a 1N914 diode. As the 4017 counts down, it turns the brake light on and off four times and then leaves it on until the brake switch is released. The on/off rate can be set by potentiometer R2; for best results, the on/off rate should be set so that it is rapid.

CAR ALARM-DECOY

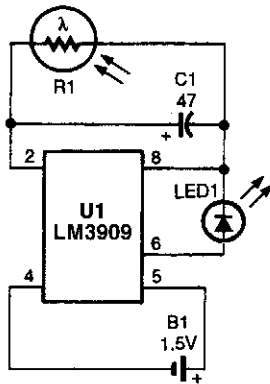

The device will simulate the presence of a burglar alarm in automobiles or homes. Mount R1 where daylight can fall on it. During darkness, LED1 flashes, making potential intruders think an alarm system is installed.

POPULAR ELECTRONICS

Fig. 3-6

MOTORCYCLE ALARM

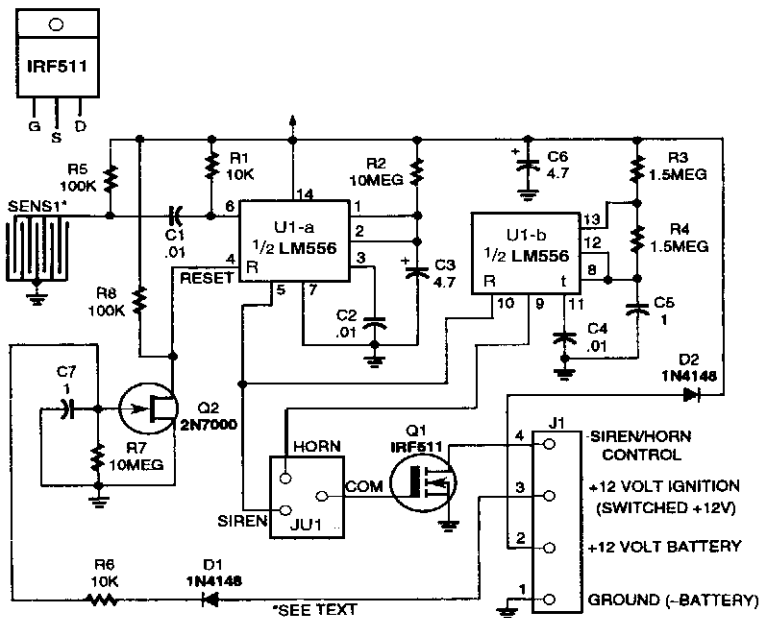

POPULAR ELECTRONICS

Fig. 3-7

A dual timer is used to generate a long pulse, which gates a second timer, producing a square wave (nonsymmetrical) and controls the on/off time of the horn. Siren operation can be selected with a jumper. In this case, the output of Q1 will be continuously on and not cycled. Sensor S1 is a row of adjacent circuit board traces with a stainless steel ball bearing laying on them. Any movement causes momentary shorting and opening of the circuit, triggering U1-a.

SIMPLE BIKE HORN

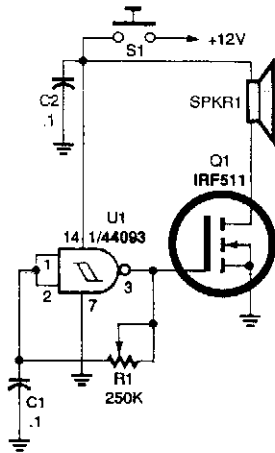

The horn circuit uses only one gate of a 4093 quad 2-input NAND Schmitt trigger, U1, connected in a simple, low-frequency, square-wave oscillator circuit. The oscillator's output, at pin 3, drives the gate of Q1. The drain of that FET drives a small horn speaker.

Potentiometer R1 can be adjusted to set the horn's output frequency. Some horn speakers are frequency sensitive, so play with the oscillator's frequency control for the best or loudest sound.

POPULAR ELECTRONICS

Fig. 3-8

DOOR AJAR INDICATOR

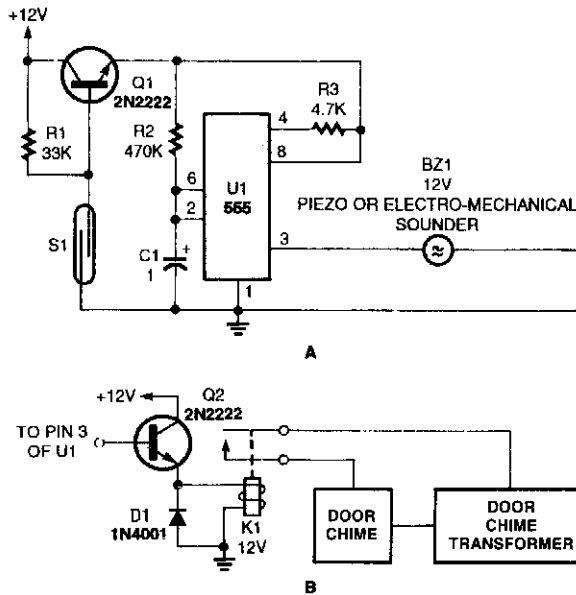

POPULAR ELECTRONICS

Fig. 3-9

This simple sounder (A) makes a good door annunciator. If the buzzer is replaced with the circuit in B, the annunciator can be made more pleasant to the ear.

MOTORCYCLE BURGLAR ALARM

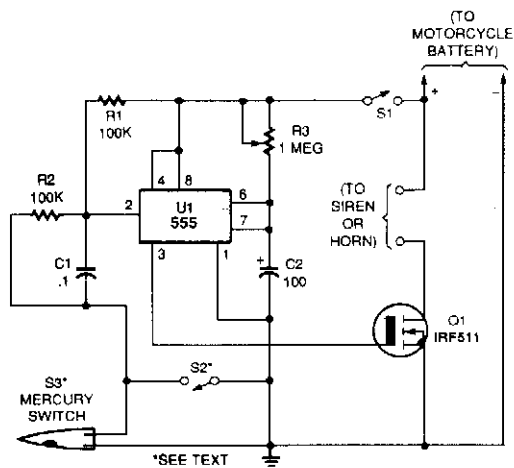

A 555 IC is connected in a one-shot timer circuit that turns on a FET transistor and either a siren or the bike's horn for a preset time period. Switch S1 is used as an on/off switch.

Closing either of two switches, S2 and S3, will trigger the IC. When either switch closes, pin 2 of U1 goes low. That triggers the IC to produce a positive output at pin 3 and sounds the alarm for the time period set by R3. The mercury switch, S3, is the switch that activates the alarm should anyone move your bike. Switch S2 can be used as a panic switch.

POPULAR ELECTRONICS

Fig. 3-10

HORN CIRCUIT FOR MOTORCYCLE USE

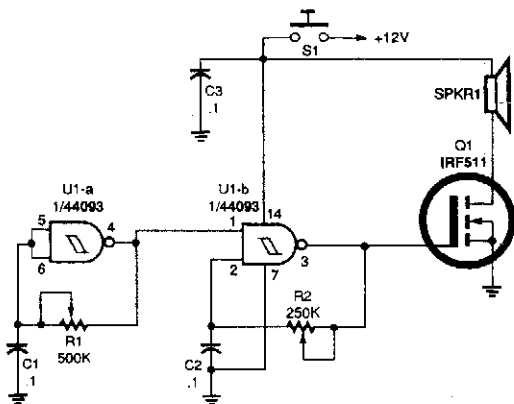

Gates U1-a and U1-b of the 4093 quad 2-input NAND Schmitt trigger are connected in variable, low-frequency, square-wave oscillator circuits. The output of gate U1-a is connected to one of the inputs of gate U1-b. The square-wave output of gate U1-a modulates oscillator U1-b, producing a two-tone output. A really interesting sound can be produced by carefully adjusting potentiometers R1 and R2.

POPULAR ELECTRONICS

Fig. 3-11

4

Amateur Circuits

The sources of the following circuits are contained in the Sources section, which begins on page 707. The figure number in the box of each circuit correlates to the entry in the Sources section.

1.2-kW 144-MHz Amplifier Power Supply
1.2-kW 144-MHz Amplifier Control Circuitry
1.2-kW 144-MHz Linear Amplifier
Four-Stage 75-Meter SSB Superhet Receiver
Improved CW Transmitter Keying Circuit
One-Chip AFSK Generator
Programmable CW Identifier
Audible SWR Detector Adapter
Audio Breakout Box
One-Watt CW Transmitter
PTT Control from Receiver Audio
Transceiver Memory Backup
80-Meter SSB Receiver
CW Audio Filter
RF Line Sampler/Coupler
Battery Pack and Reverse Polarity Protection
Simple Identifier
Transmit Keyer Interface Circuits
Mobile Radio On-Alarm Timer

1.2-KW 144-MHz AMPLIFIER POWER SUPPLY

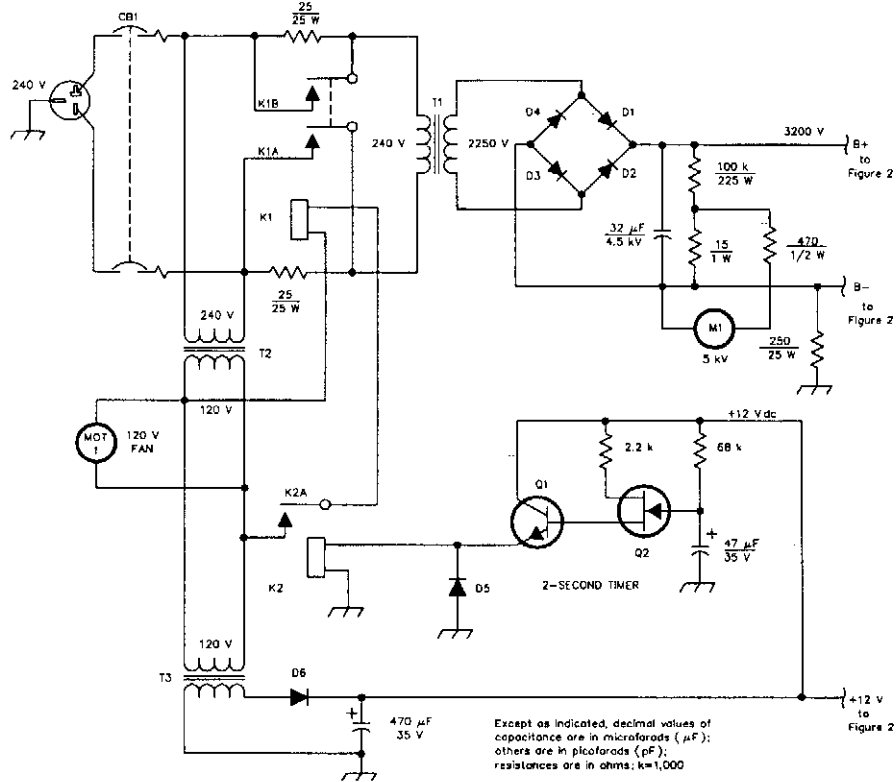

Schematic diagram of the high-voltage power supply recommended for use with the power amplifier.

D1-D4—Strings of 4 each, 1000-PIV, 3-A diodes, 1N5408 or equivalent
K1—DPST relay, 120-V ac coil, 240-V ac, 20-A contacts (Midland Floss 187-321200 or equivalent)
K2—SPDT miniature relay, 12-V dc coil (Radio Shack 275-248 or equivalent)
M1—High-voltage meter, 5 kV dc full scale

(1-mA meter movement used with series resistors shown in drawing)
MOT1—Cooling fan, Torin TA-300 or equivalent
Q1—2N2222A or equivalent
Q2—MPF102 or equivalent
S1—20-A hydraulic/magnetic circuit breaker (Potter and Brumfield W68X2Q12-20 or equivalent)

T1—High-voltage power transformer, 240-V primary, 2250-V, 1.2-A secondary (Avatar AV-538 or equivalent)
T2—Stepdown transformer, Jameco 112125, 240-V to 120-V, 100 VA
T3—Power transformer, Jameco 104379, 120-V primary, 16.4 V, 1-A secondary (half used)

QST

Fig. 4-1

A schematic diagram of the high-voltage power supply recommended for use with the power transformer. This power supply can also be used for other equipment with similar requirements. **CAUTION:** hazardous high voltages.

1.2-kW 144-MHz AMPLIFIER CONTROL CIRCUITRY

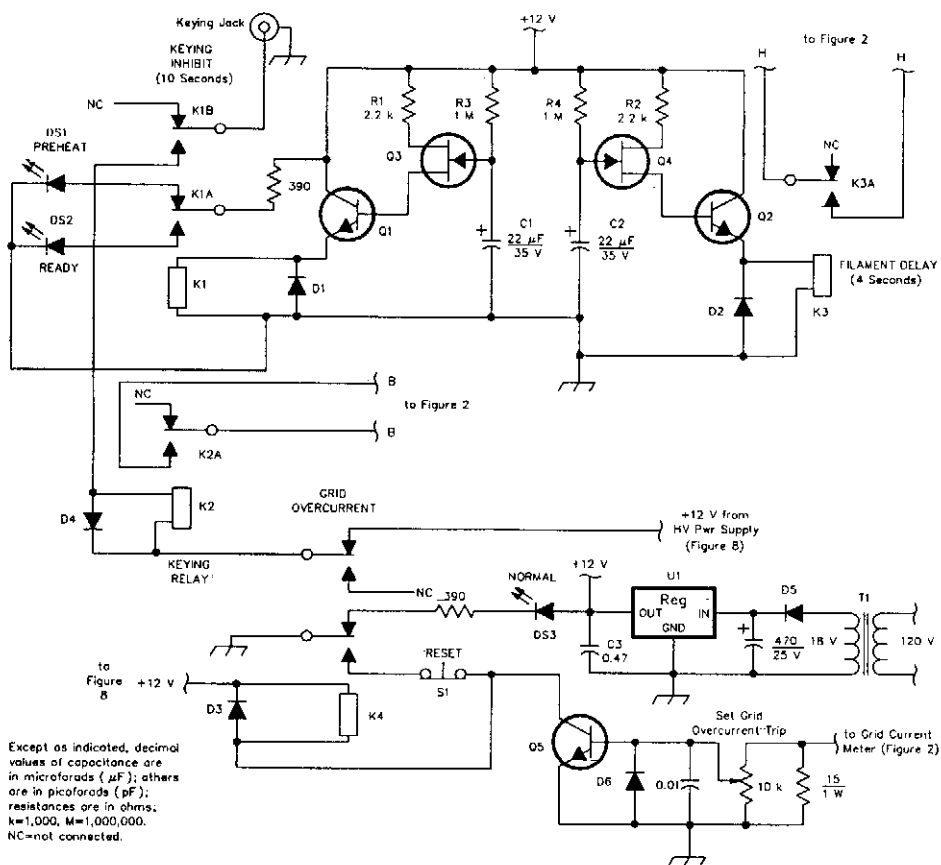

QST

Fig. 4-2

Schematic diagram of the amplifier-control circuits.

1.2-kW 144-MHz LINEAR AMPLIFIER

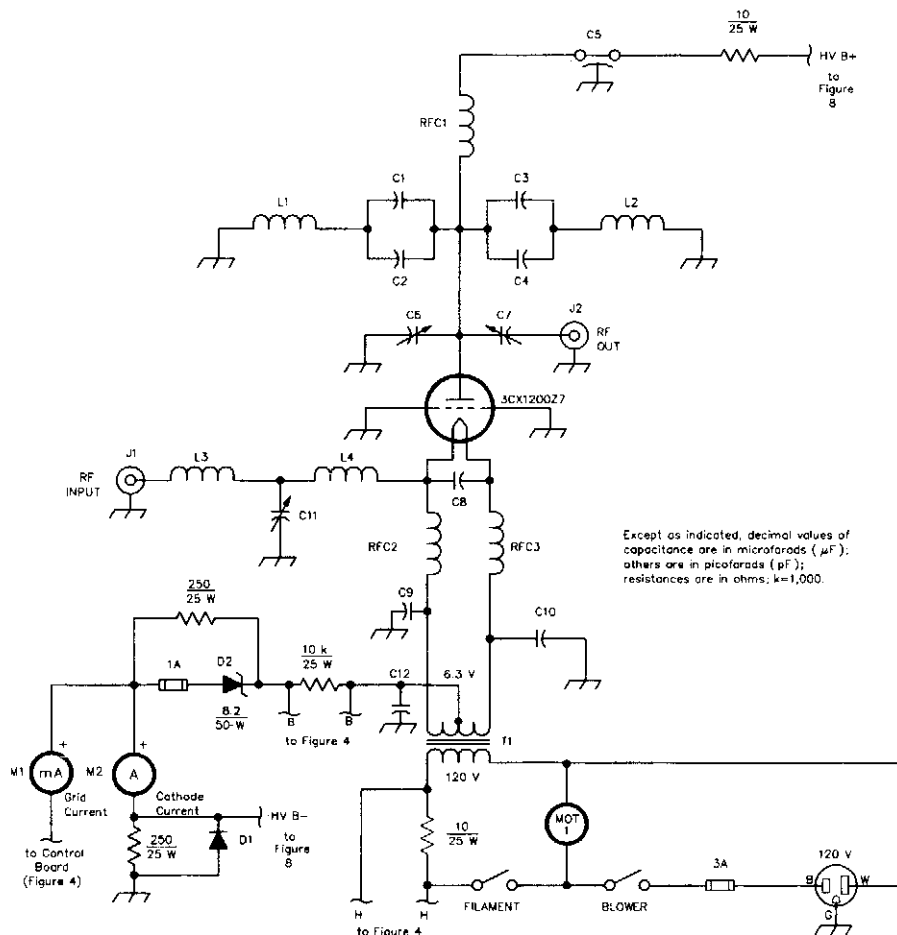

C1-C4—100 pF, 5 kV, type 850
 C5—1000 pF, 5 kV
 C6—Anode-tuning capacitor; see text and Figure 5 for details
 C7—Output-loading capacitor; see text and Figure 7 for details
 C8-C10—1000-pF silver mica, 500 V
 C11—30-pF air variable
 C12—0.01 μF , 1 kV
 D1—1000 PIV, 3-A diode, 1N5408 or equiv
 D2—8.2-V, 50-W Zener diode, ECG 5249A
 J1—Chassis-mount BNC connector
 J2—Type-N connector fitted to output coupling assembly (see Figure 7)
 L1, L2—Plate lines; see text and Figure 6 for details
 L3—5 t no. 14, $\frac{1}{2}$ -inch diameter, close wound
 L4—3 t no. 14, $\frac{5}{8}$ -inch diameter, $\frac{1}{4}$ -inch spacing
 RFC1—7 t no. 14, $\frac{5}{8}$ -inch diameter, $1\frac{1}{8}$ inch long

RFC2, RFC3—10 t no. 12, $\frac{5}{8}$ -inch diameter, 2 inches long
 T1—Filament transformer. Primary: 120 V; secondary: 6.3 V, 25 A, center tapped
 Available from Avatar Magnetics (Ronald C. Williams, W9JVF, 240 Tamara Trail, Indianapolis, IN 46217, 317-783-1211); part number AV-539
 M1—Grid milliammeter, 200 mA dc full scale
 M2—Cathode ammeter, 2 A dc full scale
 MOT1—140 free-air cfm, 120-V ac blower, Dayton 4C442 or equivalent.
 Sources for some of the "hard to get parts" include:
 Fair Radio Sales, 1016 E Eureka, Lima, OH 45802, tel 419-227-6573
 Surplus Sales of Nebraska, 1502 Jones Street, Omaha, NE 68102, tel 402-346-4750.

QST

Fig. 4-3

Schematic diagram of the 2-meter amplifier.

FOUR-STAGE 75-METER SSB SUPERHET RECEIVER

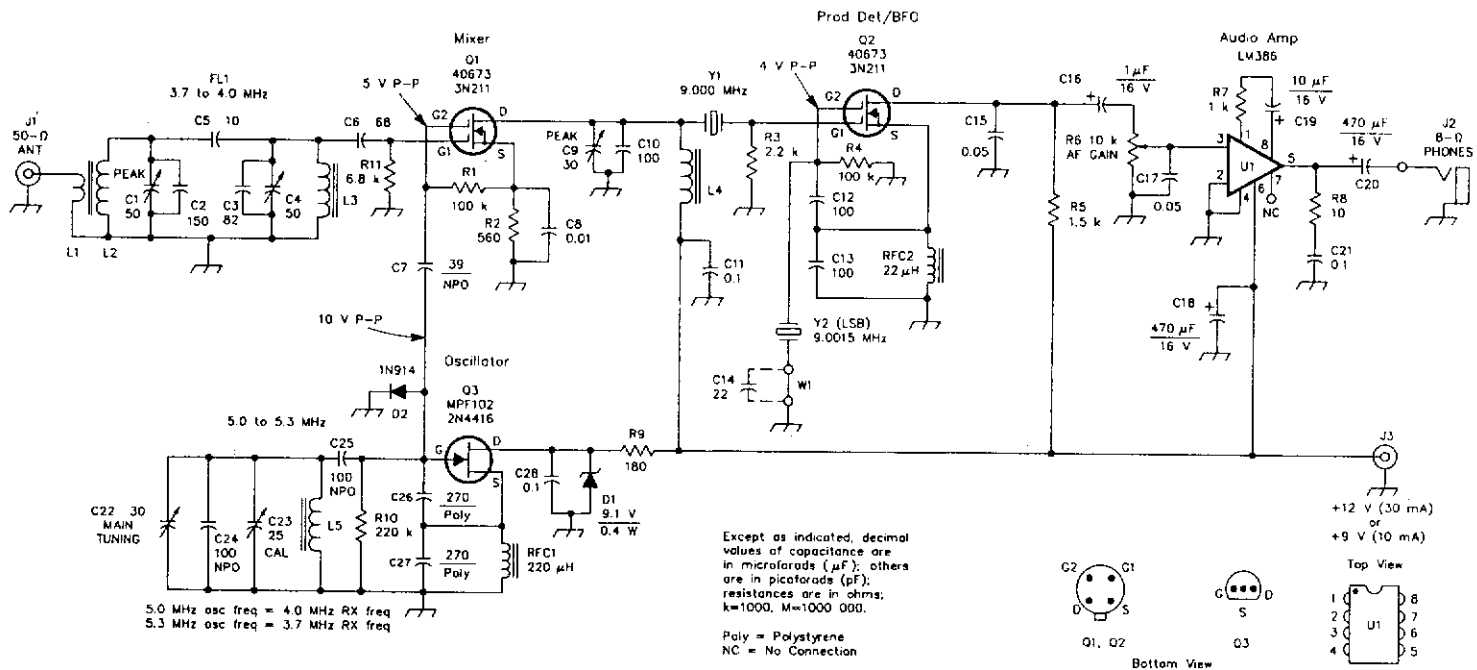

QST

Fig. 4-4

A simple superhet receiver for SSB reception in the 75-meter amateur band is shown. Y1 acts as a crystal filter.

IMPROVED CW TRANSMITTER KEYING CIRCUIT

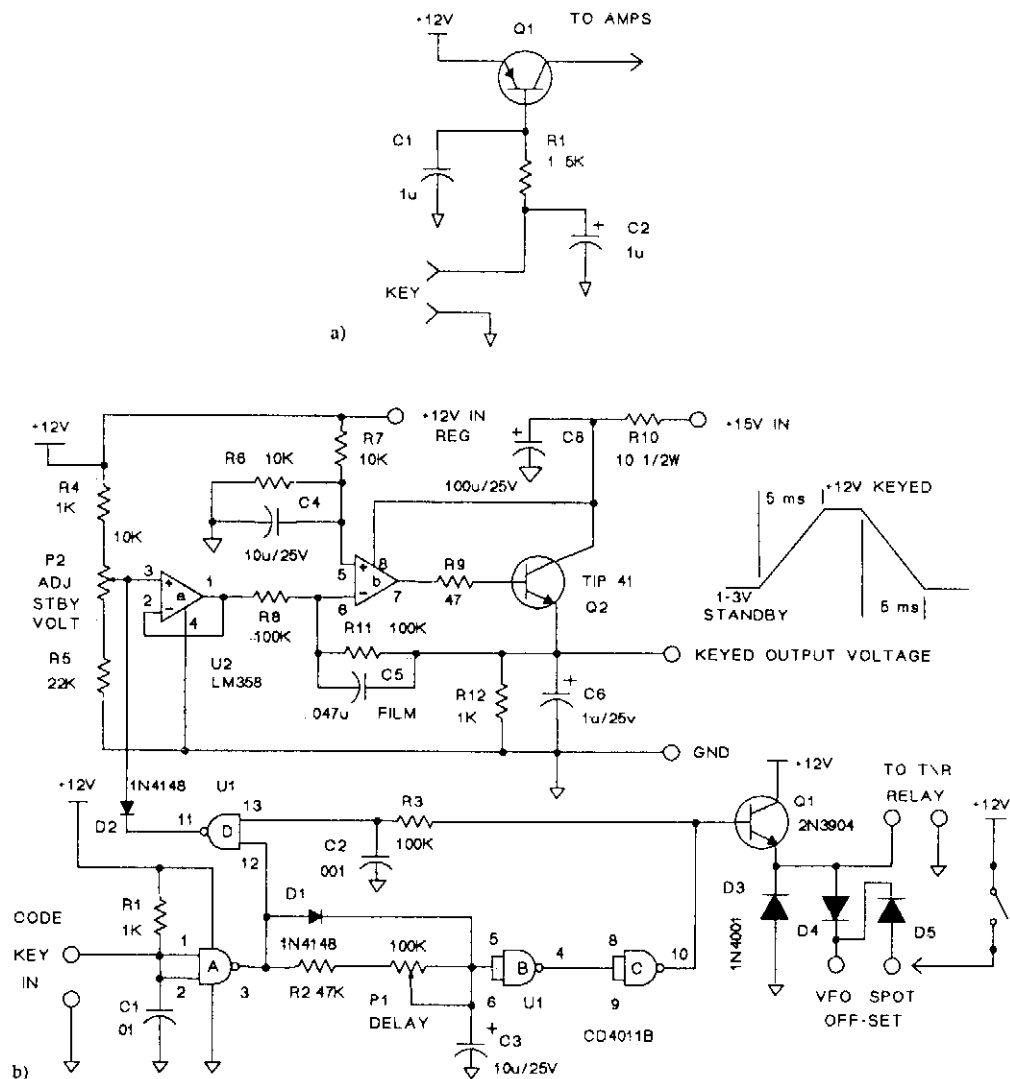

Typical (A) QRP keying circuit; (B) Improved QRP keying circuit with CMOS T/R keying control. Op amp U2b is a basic inverting amplifier with a gain of one. The capacitor C5 across the feedback resistor R11 makes it an integrator. The RC time constant of R11 and C5 determine the ramp time. The values shown will produce a 5-ms ramp. Use a good-quality capacitor for C5, such as a mylar or polypropylene type. A power transistor is placed inside the feedback loop so that the circuit can supply several hundred milliamperes of current. Control P2 sets the stand-by output voltage as seen at

IMPROVED CW TRANSMITTER KEYING CIRCUIT (Cont.)

the emitter of Q1. U2a buffers the voltage from P2. This isolates the pot from the input of the integrator. With the key up, adjust the pot until you just start to see an output from your transmitter, then back it off a little. Typically, this will be between 2 and 4 V. Your output signal will now have the proper 5-ms leading and falling edges and there will be no delay between key closure and the start of the output signal.

You must supply the op amp and collector of Q2 with at least 15 V to produce a full 12-V output on the emitter.

Parts list

R1, R4, R12	1 k Ω ¼ W	C1	0.01 μ F disk
R2	47 k Ω ¼ W	C2	0.001 μ F disk
R3, R8, R11	100 k Ω	C3, C4	10 μ F, 25 V electrolytic
R6, R7	22 k Ω	C5	0.047 μ F poly-film type
R9	47 Ω	C6	1 μ F, 25 V electrolytic
R10	10 Ω	C7	Skipped
P1	100 k Ω or 500 k Ω trimpot	C8	100 μ F, 26 V electrolytic
P2	10 k Ω trimpot	D1, D2	1N4148 diode
Q1	2N3904 NPN	D3, D4, D5	1N4001 1-A diode
Q2	Tip 41-to-220 NPN		
U1	4011B CMOS NAND gates		
U2	LM358 dual op amp		

ONE-CHIP AFSK GENERATOR

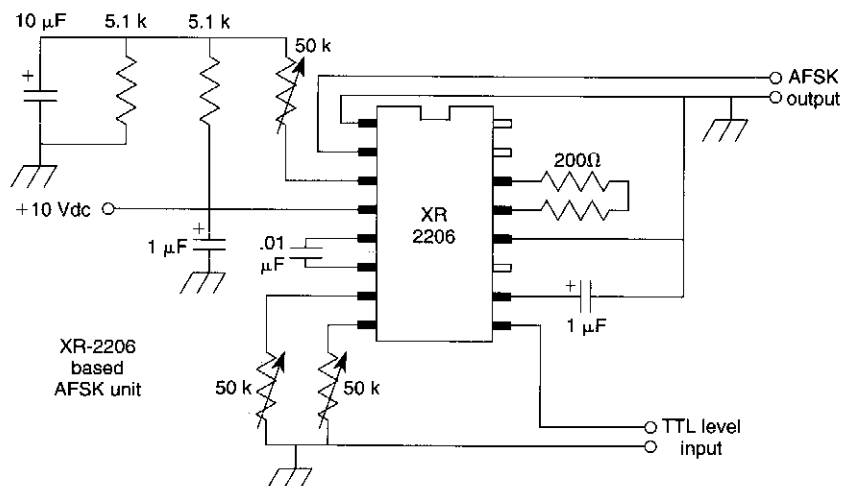

Built around an XR2206 IC, this circuit will generate AFSK signals in the 1000- to 3000-Hz range.

PROGRAMMABLE CW IDENTIFIER

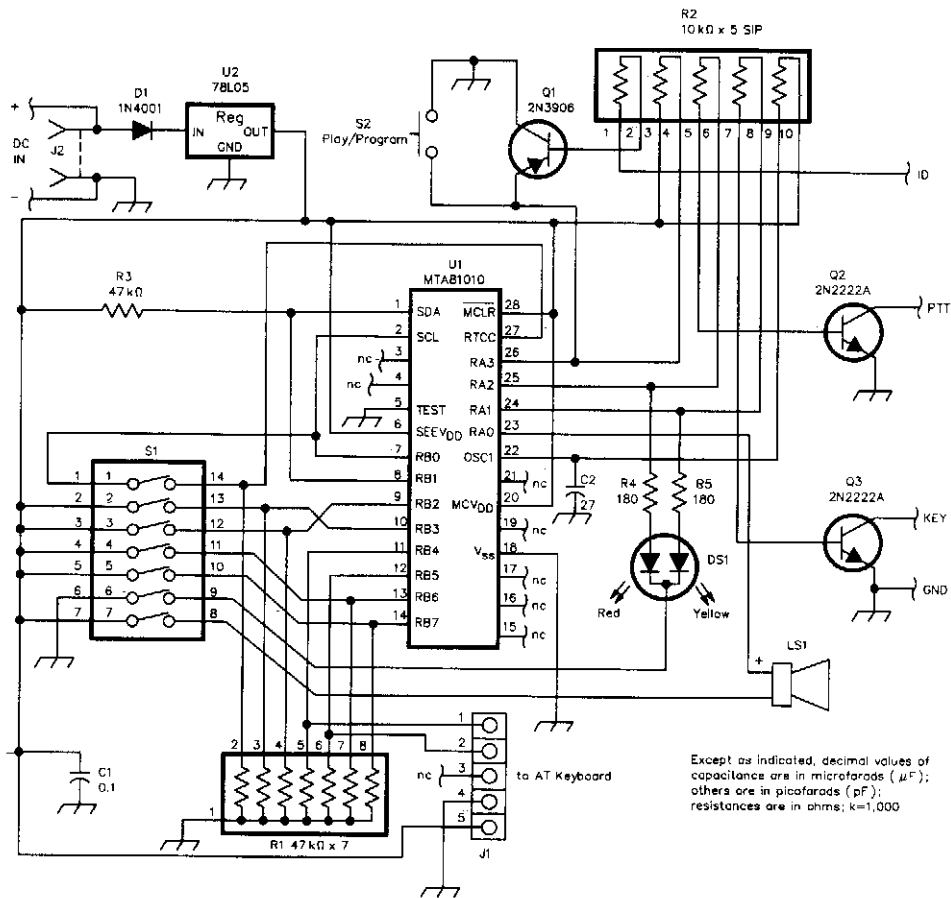

Except as indicated, decimal values of capacitance are in microfarads (μF); others are in picofarads (pF); resistances are in ohms; k=1,000

S1 Control Settings

WPM	5	7.5	10	13	15	18	20	25
S1-1	off	off	off	off	on	on	on	on
S1-2	off	off	on	on	off	off	on	on
S1-3	off	on	off	on	off	on	off	on

TIMER OFF 5 Min 10 Min Continuous

S1-4	off	off	on	on
S1-5	off	on	off	on

S1-6—DS1 on/off

S1-7—Speaker on/off

PC-Board Connections

ID—A momentary ground on this terminal causes the IDer to play its message; same as pressing the **PLAY/PROGRAM** pushbutton.

PTT—An open-collector output which goes to ground 250 ms before the CW output occurs. This output is used to place radio in transmit mode and is monitored by the red LED.

KEY—An open-collector output that goes to ground during CW keying. This output is monitored by the speaker and the yellow LED.

The identifier uses an MTA81010 microchip, containing a 1024-bit serial EEPROM and a microcontroller. It runs from a 9-V battery. A standard AT-type keyboard is used to program the desired message. Speed varies from 5 to 25 wpm.

AUDIBLE SWR DETECTOR ADAPTER

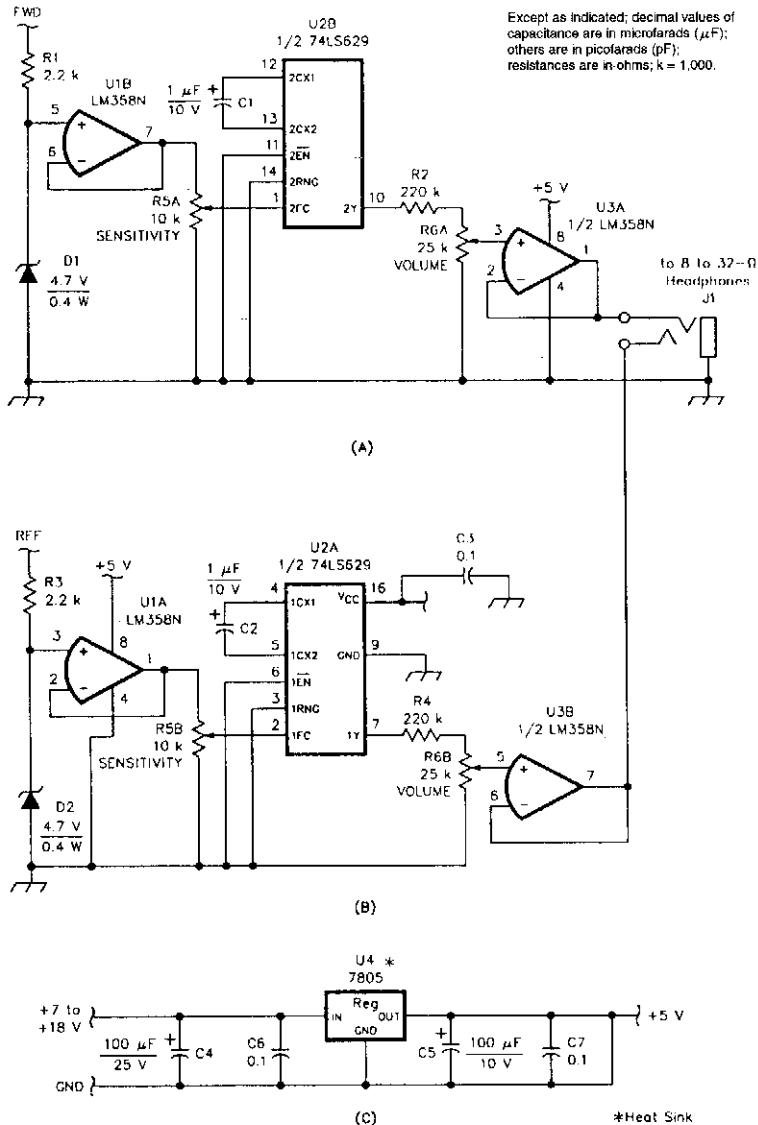

QST

Fig. 4-8

This SWR detector audio adapter is designed specifically for blind or vision-impaired amateurs, but anyone can use it. Instead of using a meter (or meters) to indicate antenna system forward and reflected voltages, this adapter generates two tones with frequencies that are proportional to the respective voltages. The tones are fed to a pair of stereo headphones (the miniature types are ideal) so that one ear hears the forward-voltage tone and the other ear hears the reflected-voltage tone. Thus, tuning up a transmitter is simply a matter of tuning for the highest-pitched tone in the left ear and the lowest-pitched tone in the right ear.

AUDIO BREAKOUT BOX

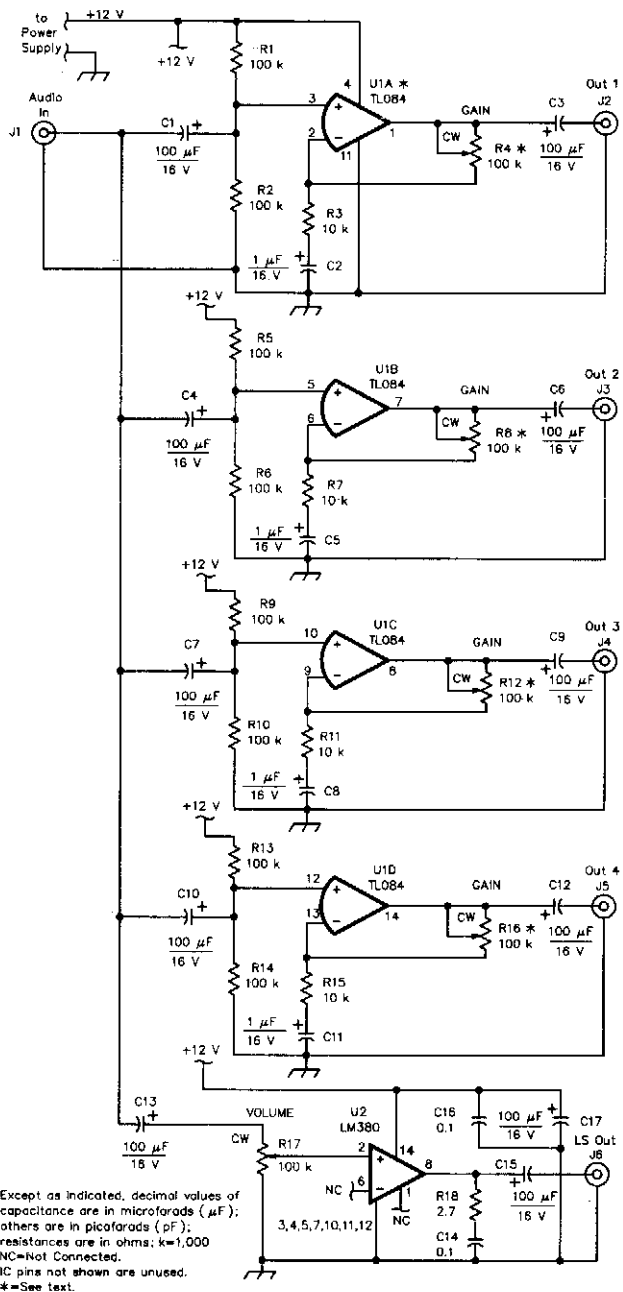

AUDIO BREAKOUT BOX (Cont.)

In many radio shacks, one receiver audio-output line feeds a multitude of add-ons, such as one or more TNXs, SSTV modems, PC plug-in boards, and, perhaps, speakers. Having to manually plug the audio source from one accessory to another is inconvenient, if not frustrating as well. Overloading the sources by connecting the loads in parallel isn't satisfactory, either.

The audio breakout box takes the audio output from a receiver (or other audio source) and applies it to the inputs of four identical, independent, low-level AF buffer/amplifiers and one high-level (1-W output) AF channel. Each low-level output channel can provide up to 20 dB of gain that's independently adjustable.

ONE-WATT CW TRANSMITTER

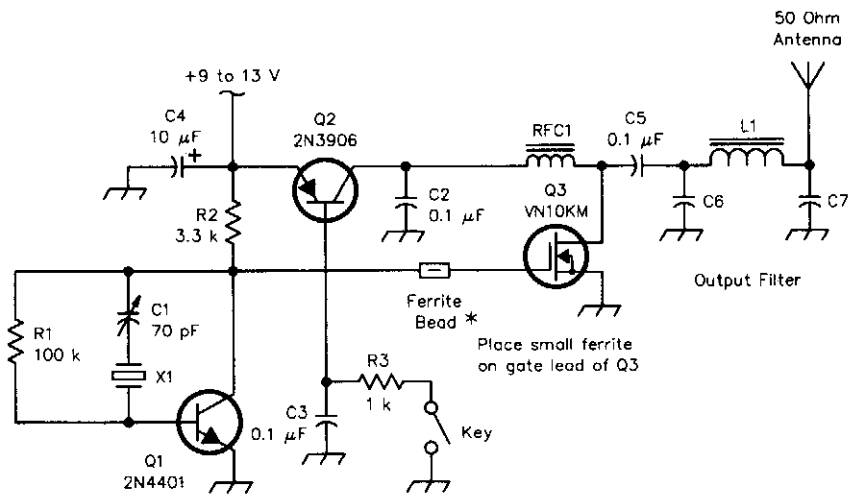

QST

Fig. 4-10

C6,C7

- 820 pF disc ceramic (160 meters)
- 470 pF disc ceramic (80 meters)
- 220 pF disc ceramic (40 meters)
- 150 pF disc ceramic (30 meters)
- 100 pF disc ceramic (20 meters)
- 82 pF disc ceramic (17 meters)

L1

- 33 turns, #30, T37-2 (160 meters)
- 23 turns, #30, T37-2 (80 meters)
- 17 turns, #26, T37-2 (40 meters)
- 14 turns, #26, T37-2 (30 meters)
- 12 turns, #26, T37-2 (20 meters)
- 10 turns, #26, T37-2 (17 meters)

PTT CONTROL FROM RECEIVER AUDIO

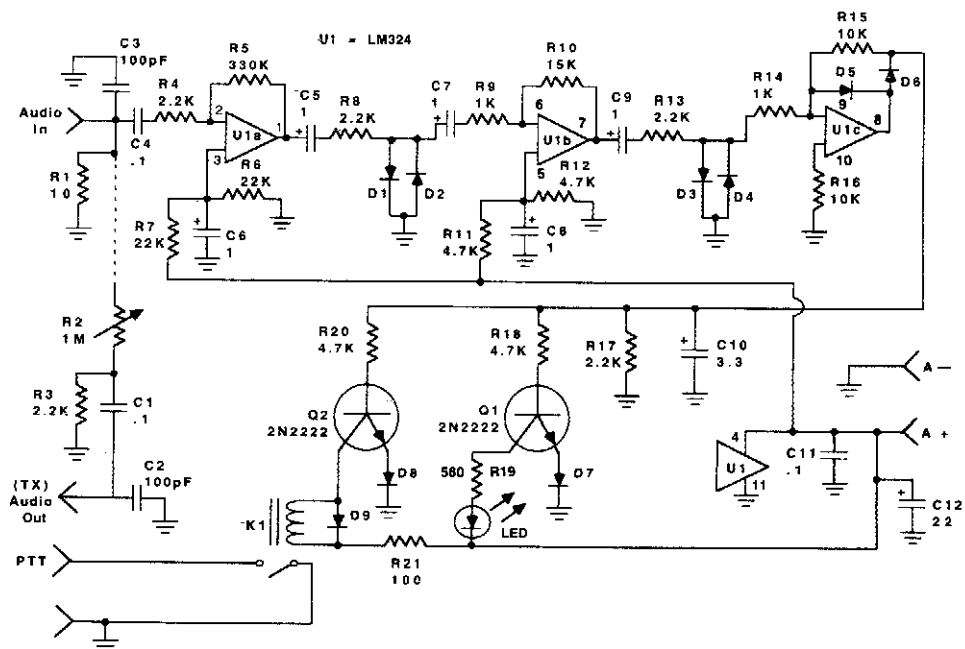

73 AMATEUR RADIO TODAY

Fig. 4-11

This system will key a transmitter or other device that can be keyed by a relay closure. Audio is amplified, limited, and is rectified and drives relay driver Q2 and LED indicator. The transmitter audio output was used to feed a keyed transmitter and can be deleted or ignored where this feature is unnecessary.

TRANSCEIVER MEMORY BACKUP

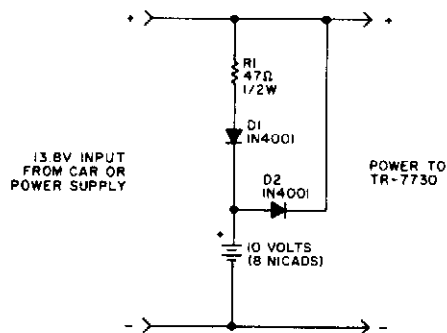

73 AMATEUR RADIO TODAY

Fig. 4-12

Although designed for a Kenwood TR7730, this idea might be adapted to other transceivers. This circuit will retain the frequencies in memory while moving the rig from car to house and vice versa. When connected to an external power source, battery B1 is charged through R1 and D1. D1 prevents B1 from discharging when connected to an external supply that is turned off. When external power is removed, D2 provides a current path to the TR-7730 to retain the memory's contents. However, the TR-7730 power switch should be turned off before external power is removed because B1 will not provide power for normal operation.

80-METER SSB RECEIVER

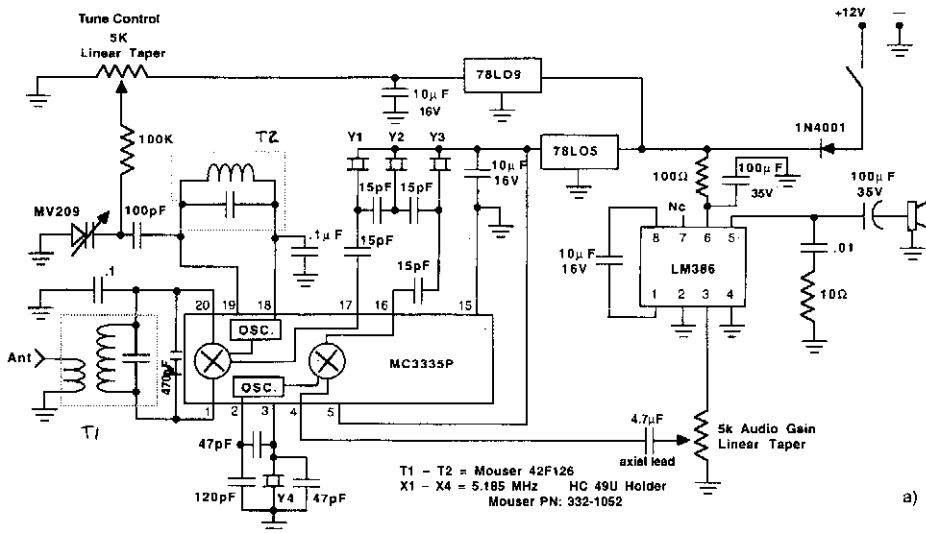

a)

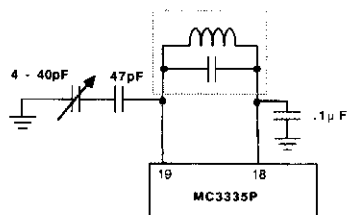

Omit VR (9 volt Reg)
C 10µ F Cap
R 100K
VD MV209 Varicap Diode

Change C From 100pF NPO to 47pF NPO

b)

73 AMATEUR RADIO TODAY

Fig. 4-13

This circuit uses an MC3335P IF chip and features a 3-pole crystal filter made from microprocessor crystals. Tuning is done either with a varactor diode or air-variable capacitor, as shown. Values are for 80 meters.

CW AUDIO FILTER

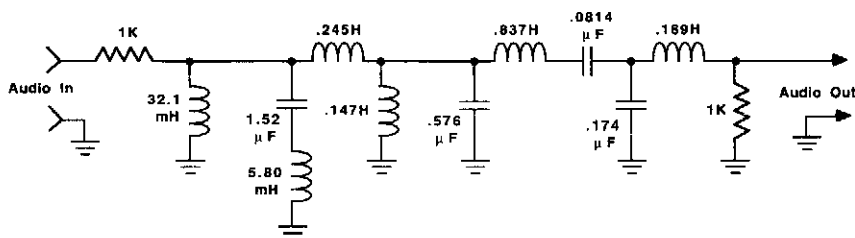

73 AMATEUR RADIO TODAY

Fig. 4-14

A high-performance passive filter. The center frequency is 700 Hz; -3-dB bandwidth is 200 Hz.

RF LINE SAMPLER/COUPLER

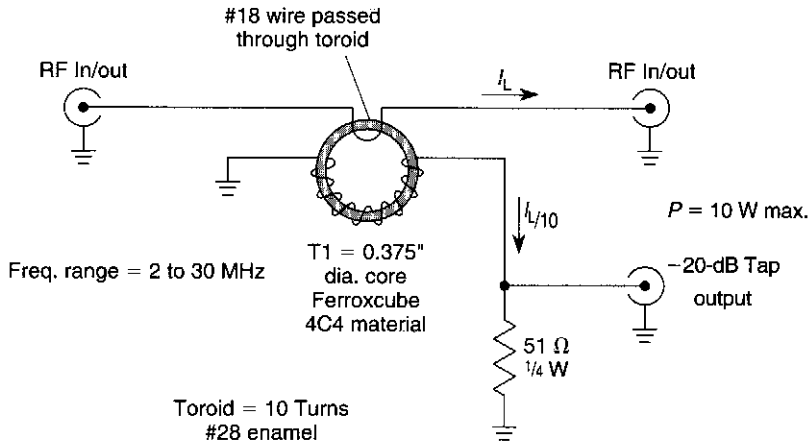

WILLIAM SHEETS

Fig. 4-15

Suitable for RF line sampling, this coupler is useful where an indirect measurement of line current is needed. A 10:1 turn ratio yields a secondary current about $\frac{1}{10}$ (ideally) of the line current. A 51- Ω resistor terminates the secondary. Insertion loss in the main line is negligible, < 0.1 dB. For higher power levels, use proportionately larger core for T1.

BATTERY PACK AND REVERSE POLARITY PROTECTION

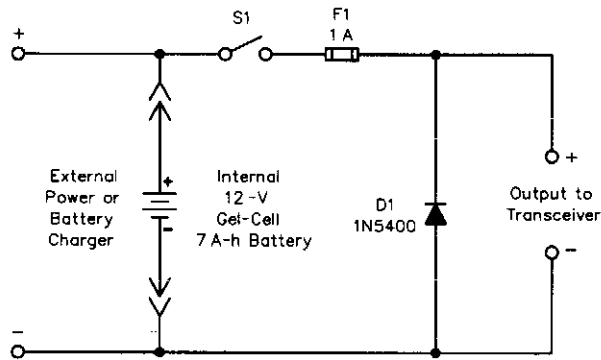

QST

Fig. 4-16

Schematic diagram and parts list for the reverse-polarity protection circuit (optional).

- D1 1N5400 silicon diode
- F1 1-A fast-acting fuse
- S1 SPST rocker switch

SIMPLE IDENTIFIER

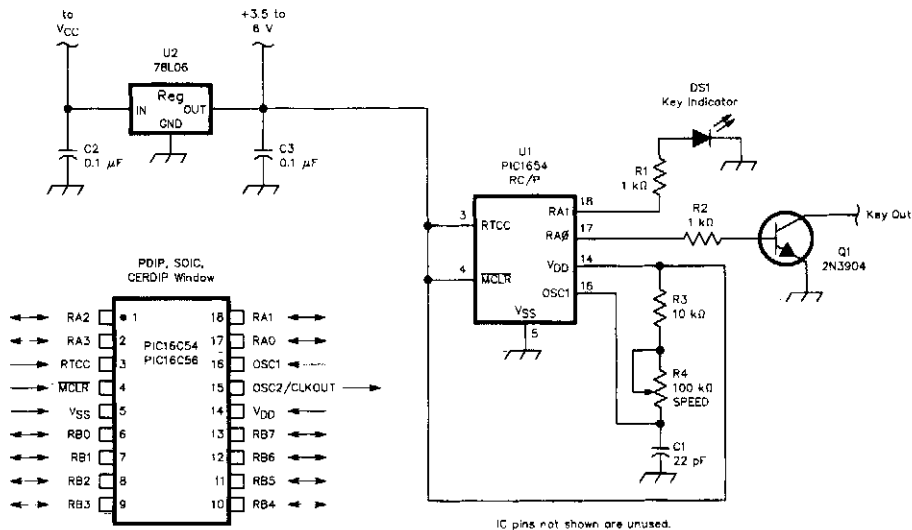

GST

Fig. 4-17

This identifier uses a PIC 16C54 microcontroller which must be programmed for your desired identifier.

TRANSMIT KEYER INTERFACE CIRCUITS

Driving the input lines

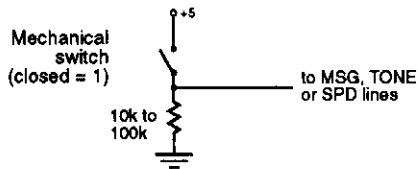
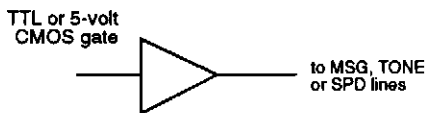

Connecting the keying output

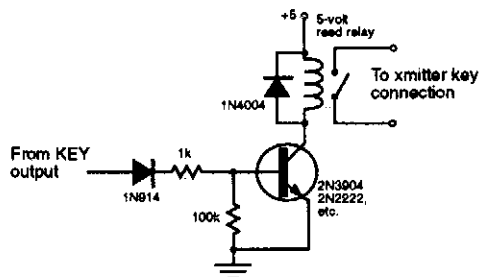
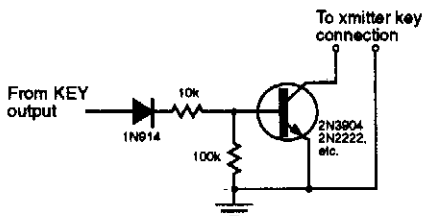

73 AMATEUR RADIO TODAY

Fig. 4-18

These circuits are for use with Morse keyers and identifiers. They can be used to interface various devices with the identifier circuitry.

MOBILE RADIO ON-ALARM TIMER

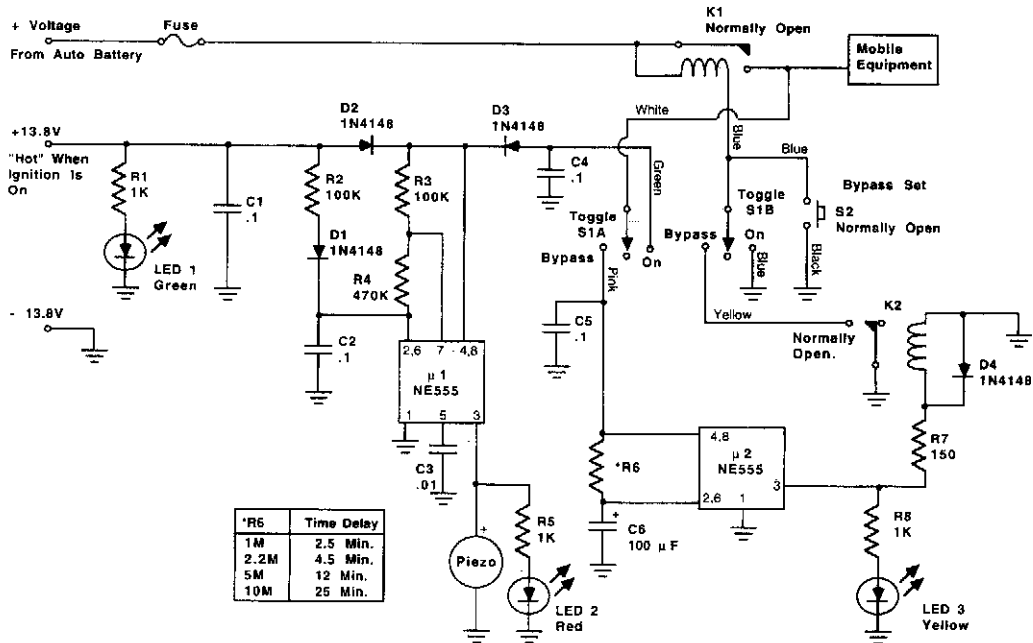

Fig. 4-19

This system will prevent you from accidentally leaving your mobile radio on, draining the battery. LED1 will light when the vehicle's ignition is on, or while the car is running. Switch S1 in the ON position will close relay K1, completing the power circuit to the equipment. If the ignition switch is shut off, and switch S1 is still in the ON position, an alarm (piezo) will begin to beep and LED2 will flash. Returning S1 to the center position will shut everything off. If equipment operation is desired after shutting off the vehicle, you can place switch S1 in the AUTO position and momentarily press S2, a normally open push-button switch. Depressing this switch begins a timing cycle. The length of time that the Mobile-ON alarm/timer operates before shutting everything off can be "programmed" by selecting R6. The approximate time delays are provided in the chart with the schematic. Or, you could change the value of C6. These components control the holding time of relay K1. LED3 will light while the circuit is in AUTO status. Incidentally, you can also cancel the time delay at any time during the delay period by simply switching it off.

5

Amateur Television (ATV) Circuits

The sources of the following circuits are contained in the Sources section, which begins on page 707. The figure number in the box of each circuit correlates to the entry in the Sources section.

5-W ATV Transmitter for 440 MHz
5-W ATV Transceiver
Mini ATV Transmitter
Dummy Load and Video Detector for Transmitter Tests
Mast-Mounted ATV Preamp
Three-Channel 902- to 928-MHz ATV Transmitter
ATV Downconverter for 902 to 928 MHz
Three-Channel 420- to 450-MHz ATV Transmitter
ATV Downconverter for 420 to 450 MHz

5-W ATV TRANSMITTER FOR 440 MHz

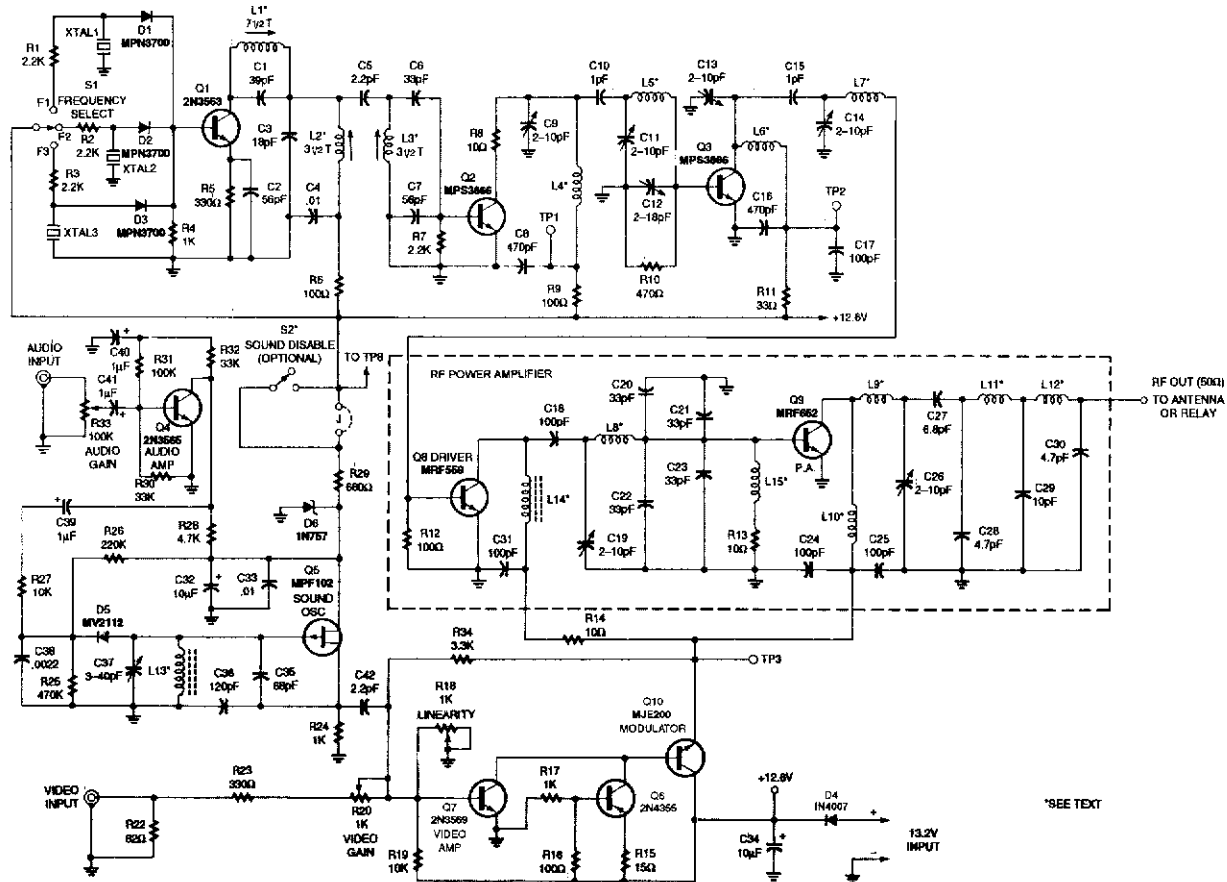

ELECTRONICS NOW

Fig. 5-1

The circuit will produce typically 6 W RF output on synch tips. A crystal oscillator drives a doubler to produce a 220-MHz output. Another doubler produces 440 MHz to drive the power amplifier. A high-level series modulator provides the video modulation capability. A sound subcarrier is generated using a VCO circuit and combined with the video information. A complete kit of parts, including the PC board, is available from North Country Radio, P.O. Box 53, Wykagyl Station, New Rochelle, NY 10804-0053A.

5-W ATV TRANSCEIVER

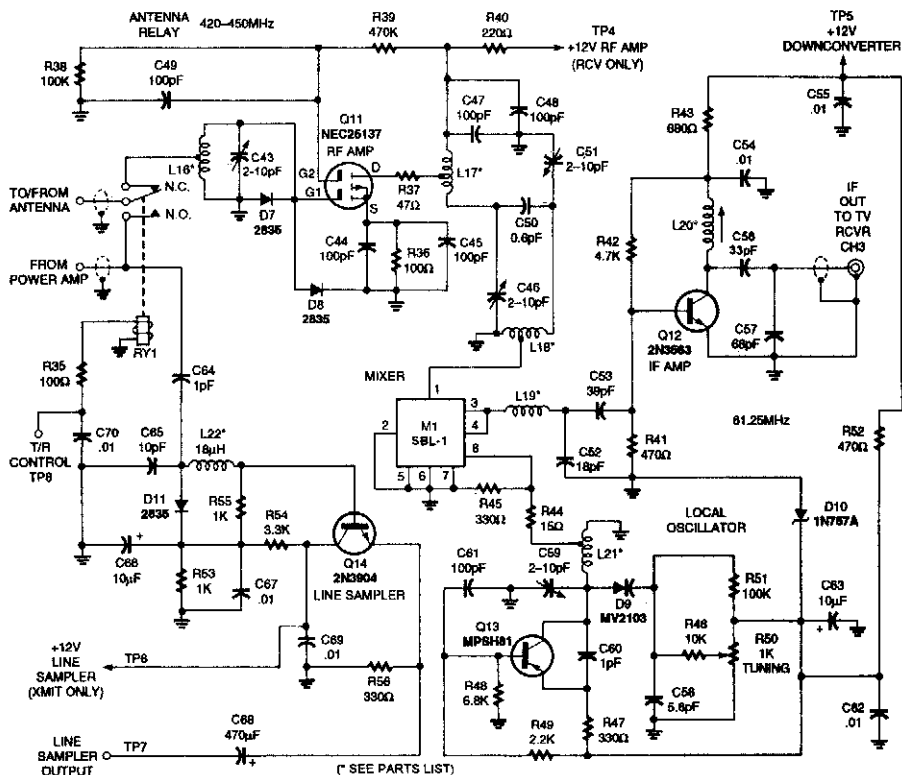

ELECTRONICS NOW

Fig. 5-2

For the transmitter schematic (part of this transceiver), see entry entitled "5-W ATV Transmitter for 440 MHz, Fig. 5-1." The downconverter portion is shown here.

This transmitter contains both a video and sound section. Five to six watts PEP on synch tips of NTSC video are produced. Three channels are available. Channel switching is via PIN diodes. Power supply voltage is 12 to 14 Vdc. The receiver function is provided with a downconverter circuit and is tunable. A relay is used for T-R switching. A complete kit of parts, including PC board, is available from North Country Radio, P.O.Box 53, Wykagyl Station, New Rochelle, NY 10804-0053A.

MINI ATV TRANSMITTER

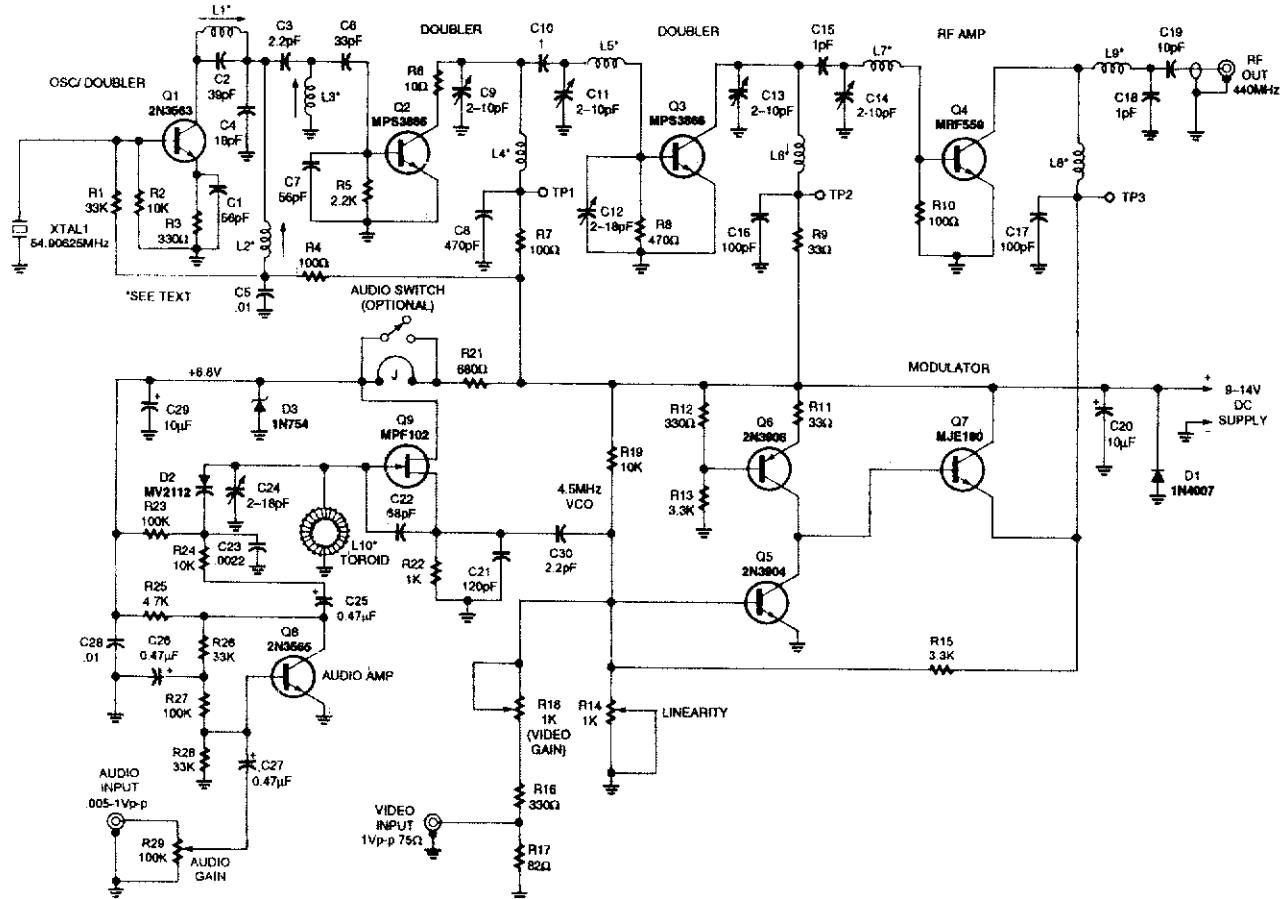

ELECTRONICS NOW

Fig. 5-3

This low-power NTSC video and sound transmitter is useful for amateur radio, video handie-talkie, R/C and surveillance purposes. A crystal oscillator-multiplier RF power amplifier. Video modulation is via a three-transistor series modulator. The sound subcarrier is generated with a VCO circuit and is combined with the video information. The output is 0.4 to 1.2 W with supply voltages of 9 to 14 volts. A complete kit of parts, including PC board, is available from North Country Radio, P.O. Box 53, Wykagyl Station, New Rochelle, NY 10804-0053A.

DUMMY LOAD AND VIDEO DETECTOR FOR TRANSMITTER TESTS

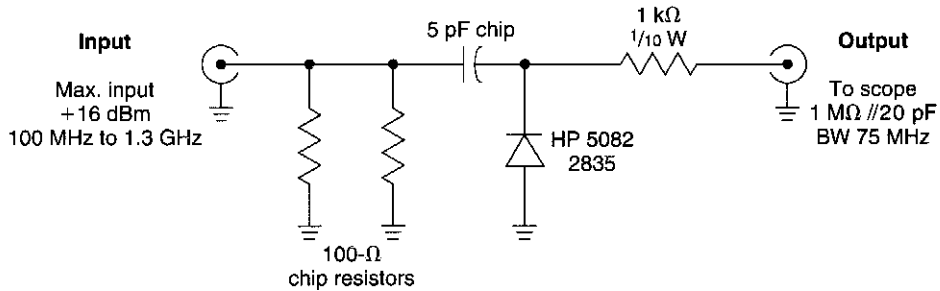

WILLIAM SHEETS

Fig. 5-4

This circuit is useful as a video modulation monitor for testing low-power video transmitters. For higher power inputs, use a suitable attenuator between the detector and the source. The detector should be connected to scope with as short a cable as possible to preserve video bandwidth.

MAST-MOUNTED ATV PREAMP

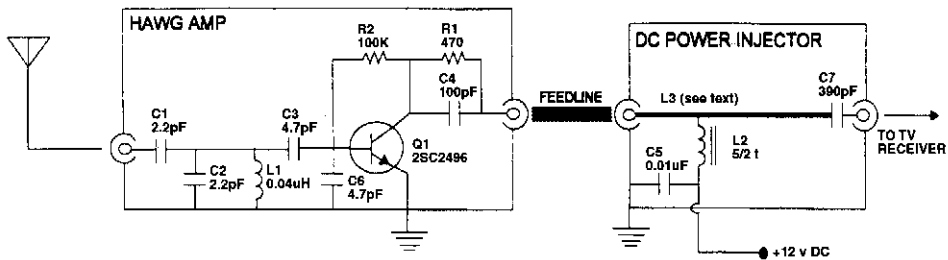

73 AMATEUR RADIO TODAY

Fig. 5-5

This simple ATV preamp covers the 427- to 439-MHz ATV frequencies and can be mast mounted and dc powered through the feedline.

THREE-CHANNEL 902- TO 928-MHz ATV TRANSMITTER

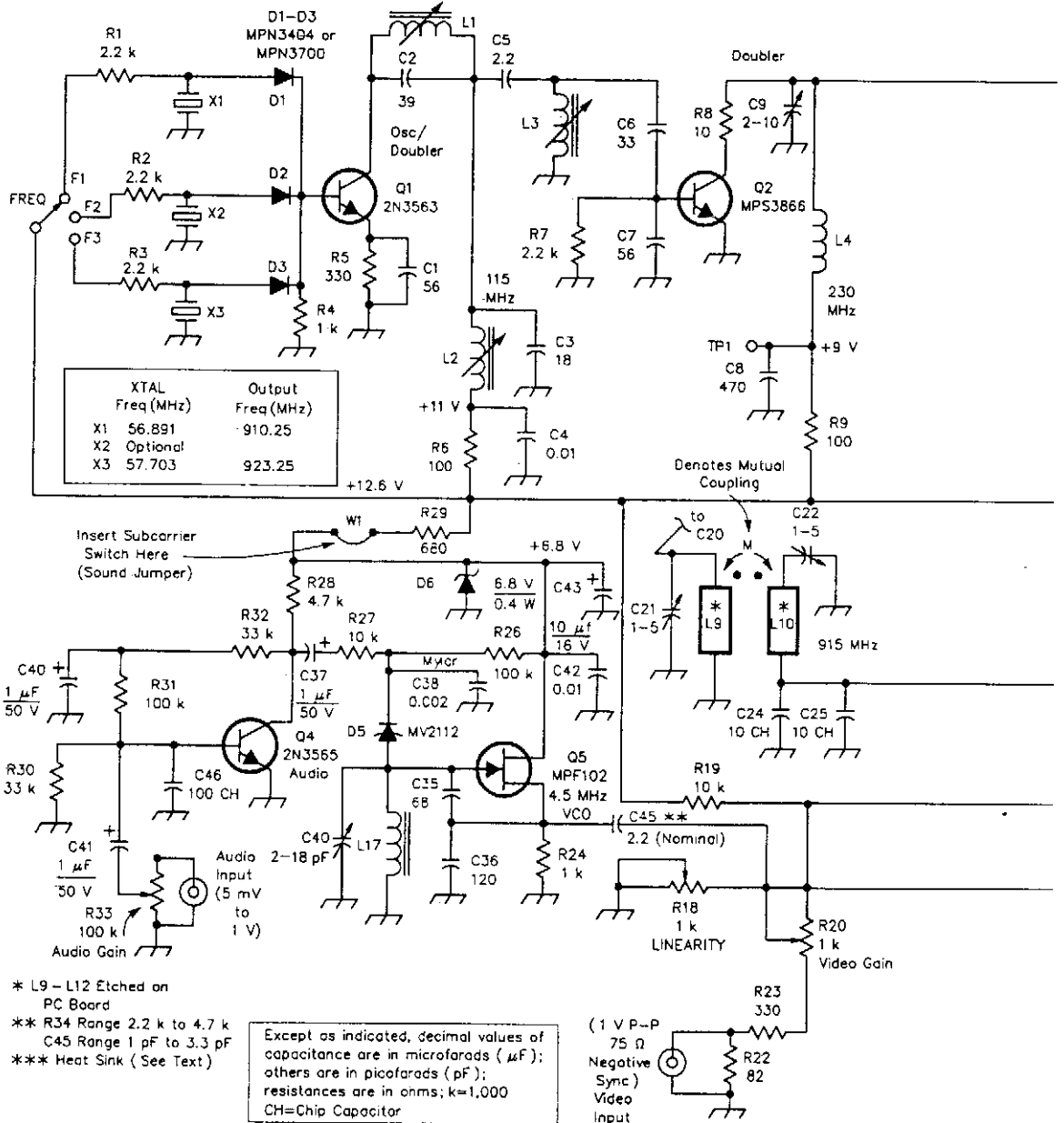

QST

This transmitter is for ATV applications in the 902- to 928-MHz band. It has three crystal-controlled channels, and will accept standard NTSC video input. It also has a 4.5-MHz sound subcarrier. Because this is an AM transmitter, audio can be transmitted as AM on the RF carrier. Simply use the

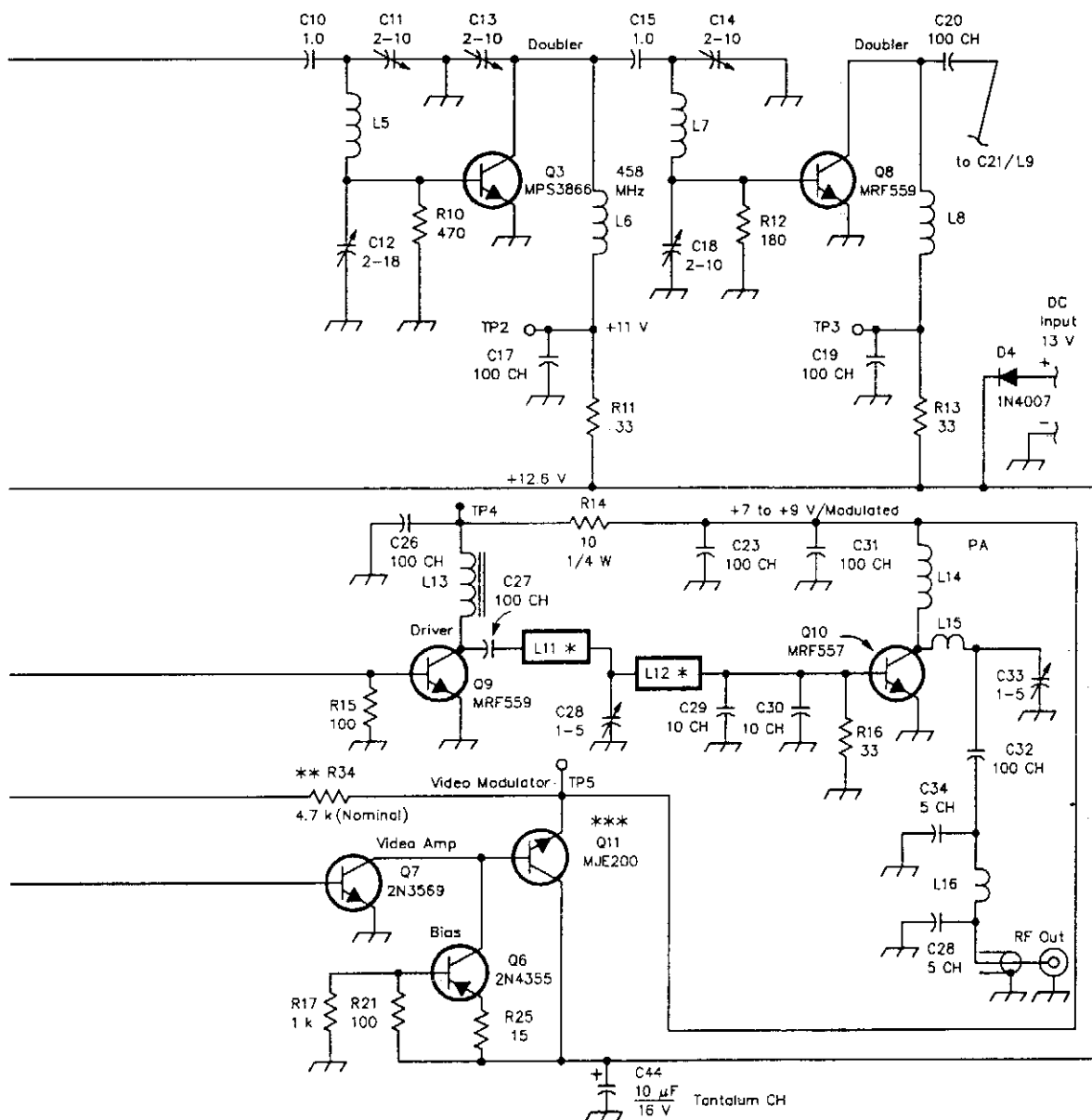
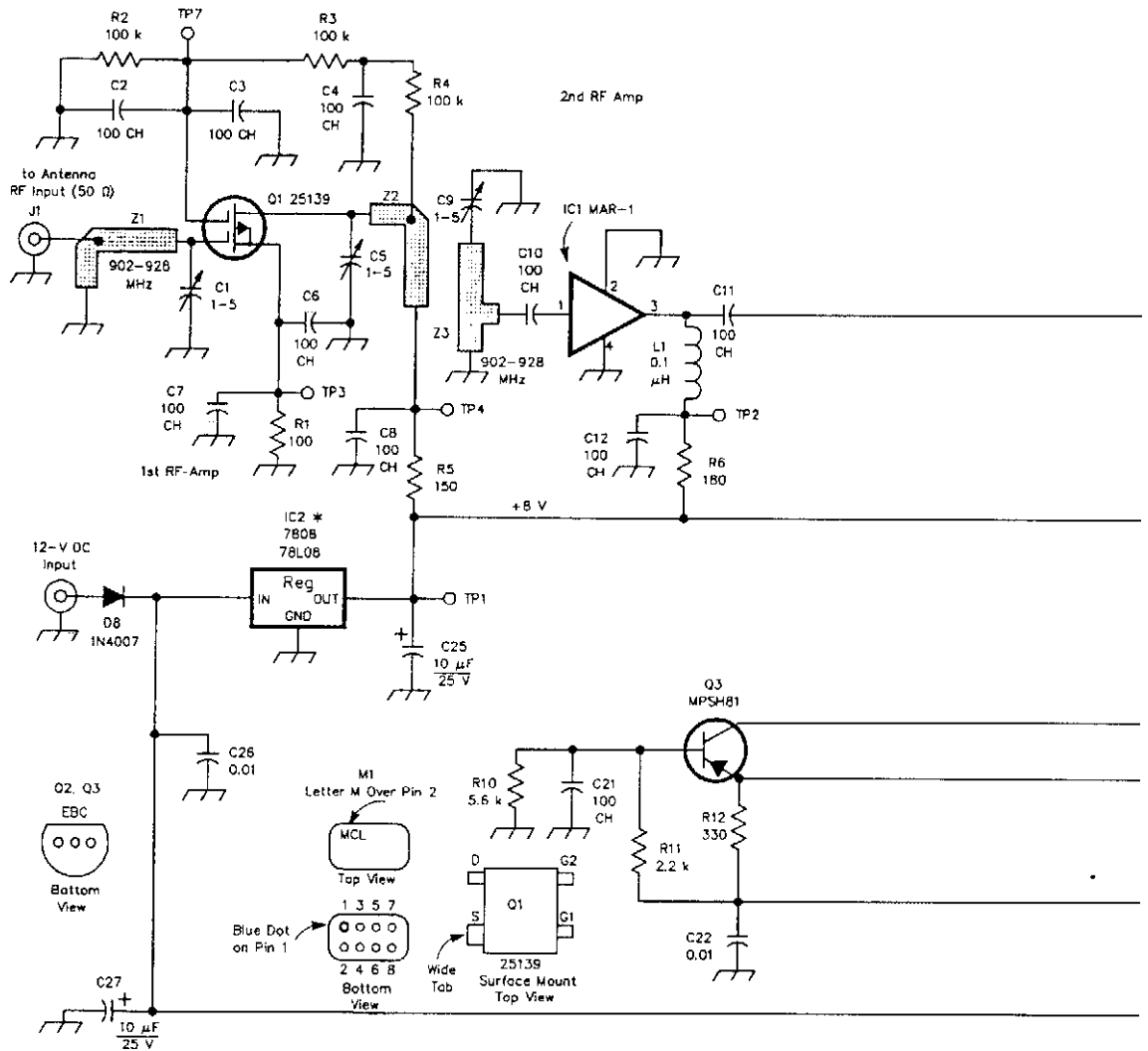

Fig. 5-6

video input. Bandwidth of audio can be restricted to 20 kHz by placing a capacitor with a value of about $0.002 \mu\text{F}$ across R34. The output is 1.5 to 2 watts PEP into a $50\text{-}\Omega$ load. A complete kit of parts including PC board, is available from North Country Radio, P.O. Box 53, Wykagyl Station, New Rochelle, NY 10804-0053A.

ATV DOWNCONVERTER FOR 902 TO 928 MHz



QST

This downconverter converts ATV signals in the 902- to 928-MHz range to a 61.25- or 67.25-MHz IF output frequency (CH 3 or CH 4) to enable reception of these signals on a standard VHF TV receiver or monitor. It features a low-noise RF amp feeding a Schottky diode double-balanced mixer, a tunable LO and one IF preamp stage. The RF amplifier is a low-noise dual-gate GASFET that is followed by a second RF stage using an MMIC. Five tuned circuits are used in the RF amplifier. This feeds a packaged Schottky diode mixer assembly for better dynamic range and reduced susceptibility to intermodulation and strong signal areas. The on-board local oscillator (LO) is voltage tuned and if desired can be set up for remote tuning. All necessary circuitry for remote tuning is on board for coax dc and IF feed. This en-

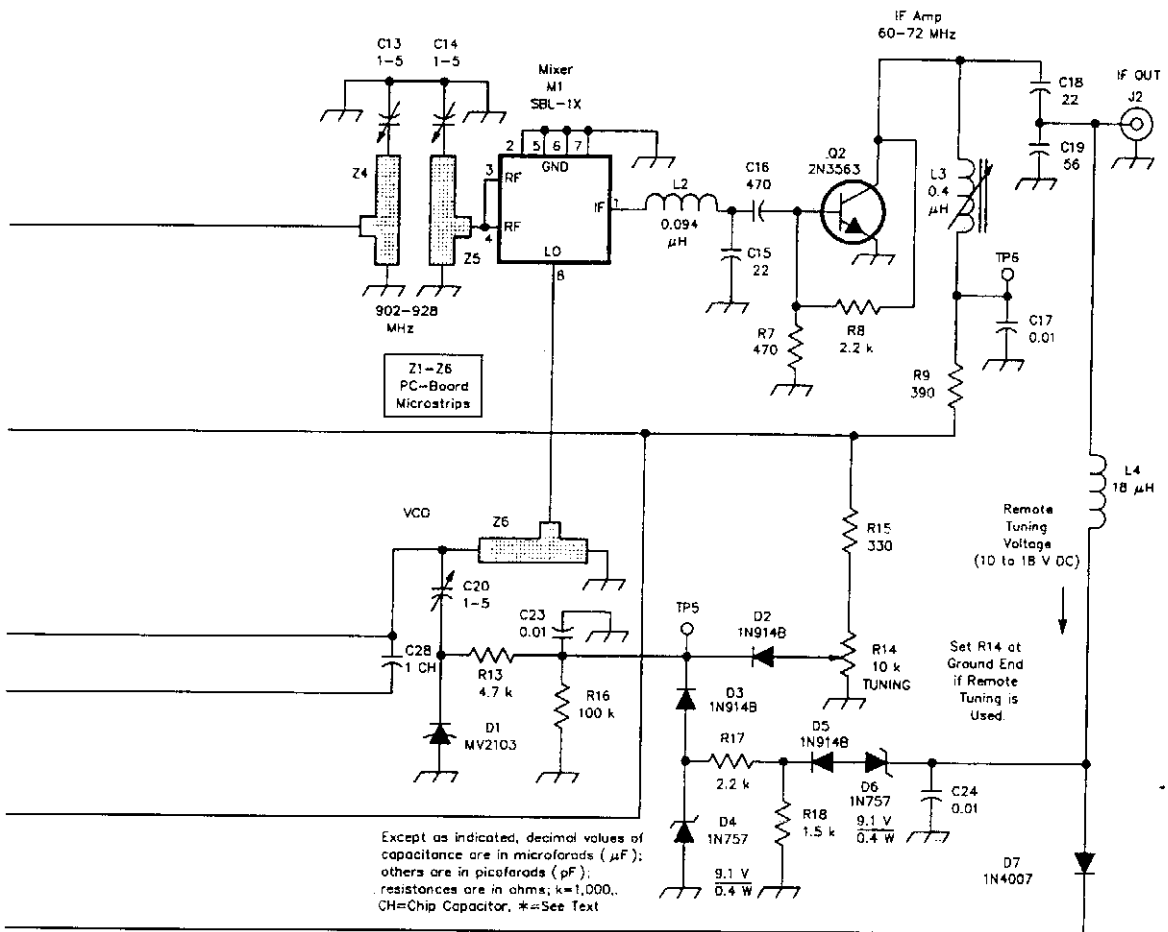
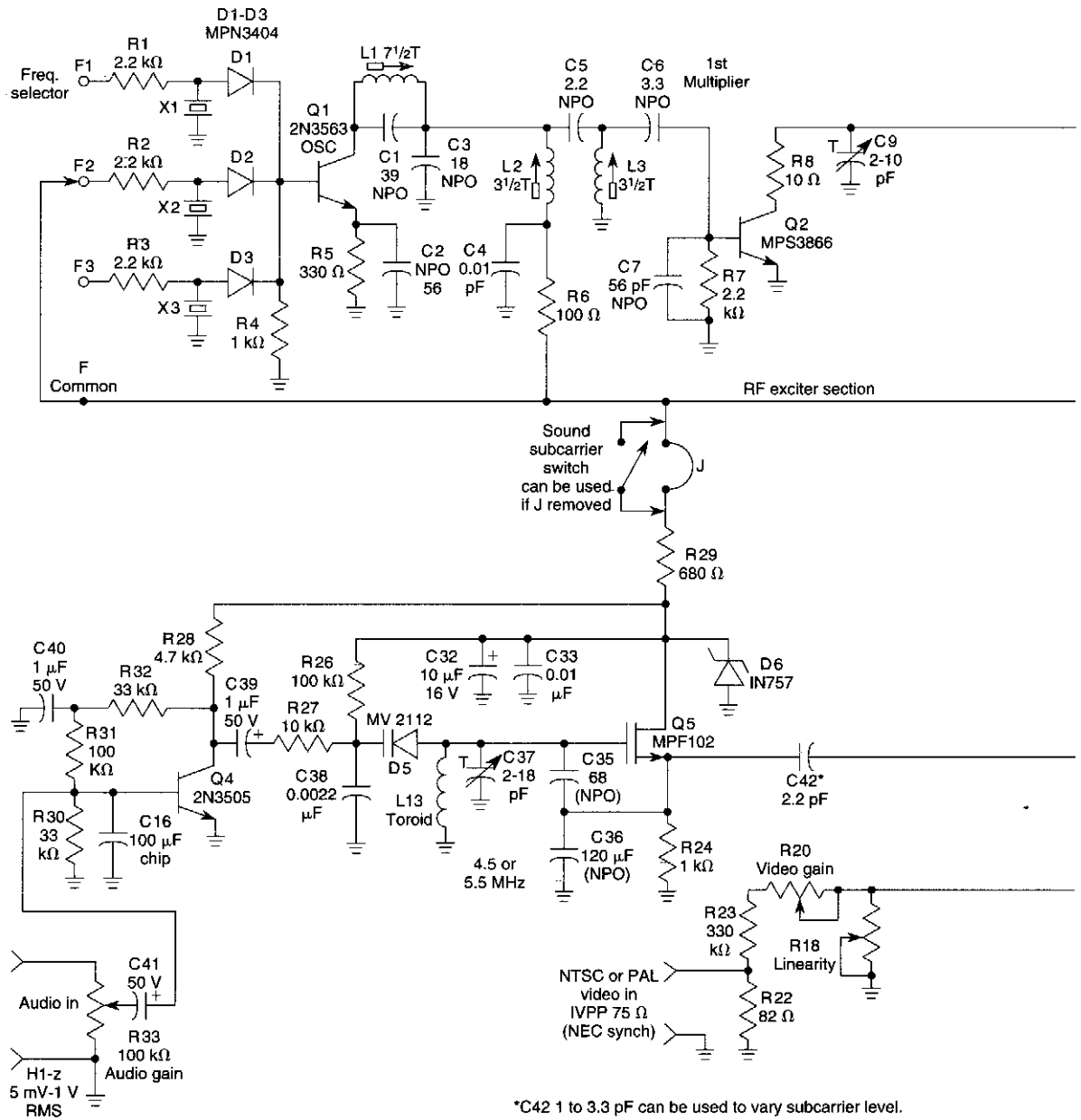

Fig. 5-7

ables the downconverter to be mast mounted to get around feedline losses generally associated with this frequency range. No separate dc feed is necessary because the coax (RG59/U recommended) carries dc power, tuning voltage, and IF signal. A dc block is used at the receiver for the purpose of separating dc voltage supply and the tuning voltage. This allows a cable run of several hundred feet, if needed.

By using this downconverter and transmitter, a physically small 915-MHz ATV station or even a video HT can be constructed because both units are each 2.50 × 4.00 inches × 1.00 high, and can be stacked together. A complete kit of parts, including PC board is available from North Country Radio, P.O. Box 53, Wykagyl Station, New Rochelle, NY 10804-0053A.

THREE-CHANNEL 420- TO 450-MHz ATV TRANSMITTER



RUDOLF F. GRAF AND WILLIAM SHEETS

This transmitter is a 2-watt PEP output device for 420- to 450-MHz amateur TV operation. It has three crystal-controlled channels and will accept standard NTSC video input. It also has a 4.5-MHz sound subcarrier capability. Because this transmitter has AM modulation, audio can be transmitted in

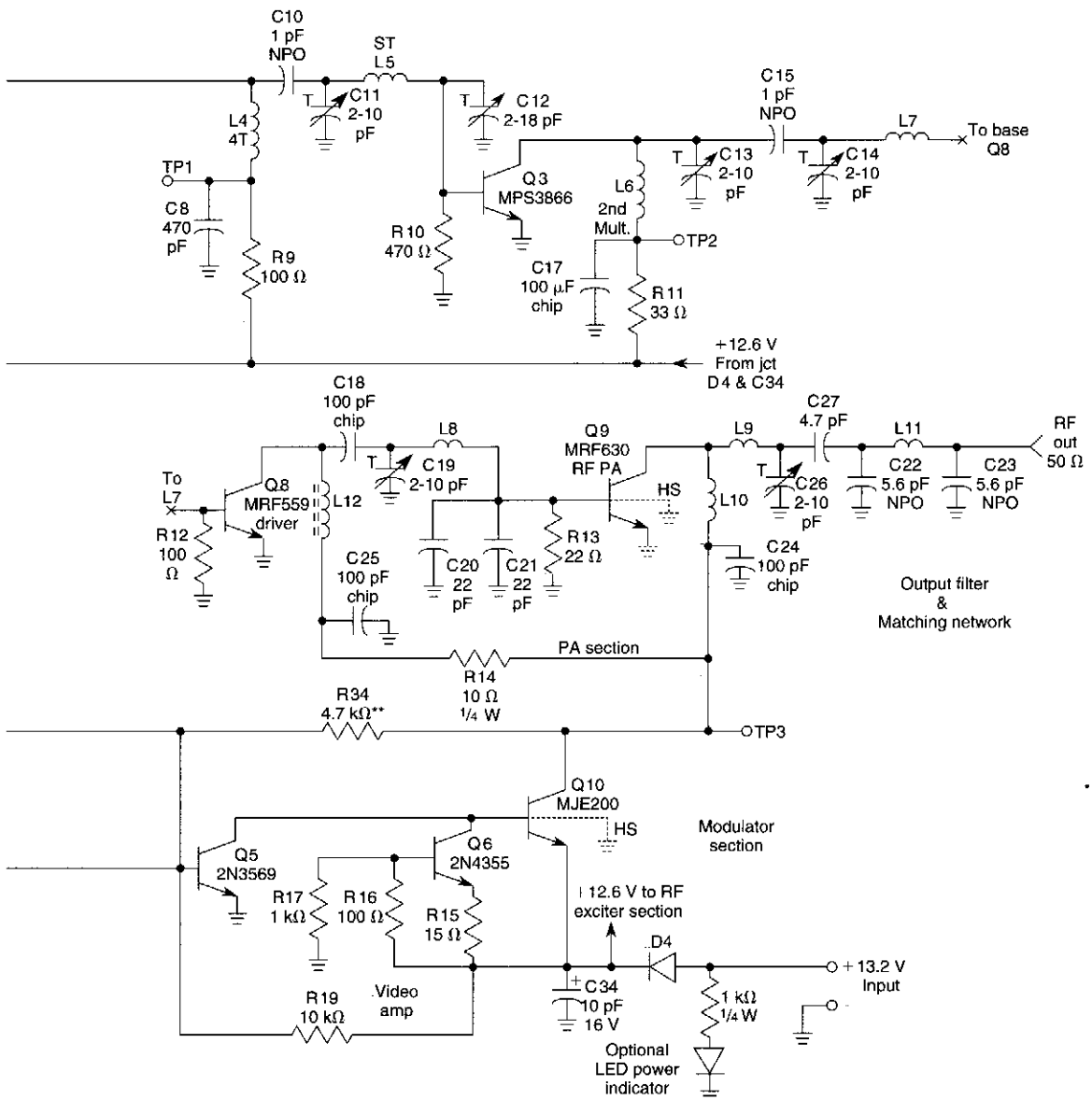
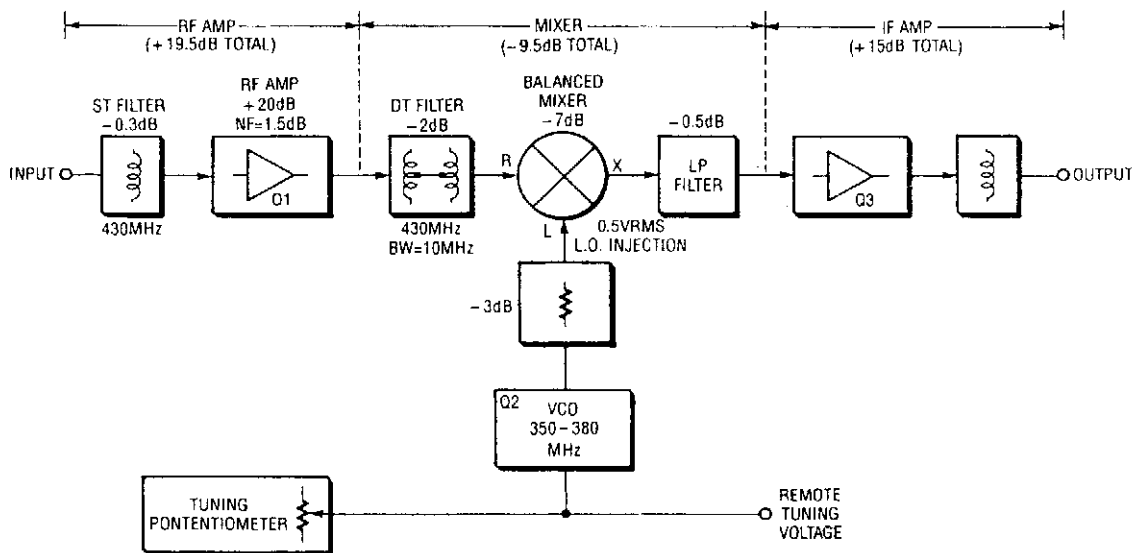

Fig. 5-8

AM form on the RF carrier by applying audio to the video input. Bandwidth of audio can be restricted to 20 kHz by placing a 0.002- μF capacitor across R34. A complete kit of parts, including PC board is available from North Country Radio, P.O. Box 53, Wykagyl Station, New Rochelle, NY 10804-0053A.

ATV DOWNCONVERTER FOR 420 TO 450 MHz



RADIO-ELECTRONICS

Fig. 5-9

This ATV downconverter converts the 420- to 450-MHz ATV band, which is several channels below the lower limit of the UHF band, to channel 3 or 4 for viewing on virtually any TV. The downconverter has a low-noise preamplifier stage and a double-balanced passive mixer for good performance and a wide dynamic range. That is necessary with today's crowded UHF bands. The converter draws about 27 milliamperes from a 13.2-volt dc source, so it can be used in portable and mobile applications. An extra IF stage gives an overall gain of about 25 dB. A block diagram of the downconverter is also shown. A complete kit of parts, including PC board, is available from North Country Radio, P.O. Box 53, Wykagyl Station, New Rochelle, NY 10804-0053A.

ATV DOWNCONVERTER FOR 420 TO 450 MHz (Cont.)

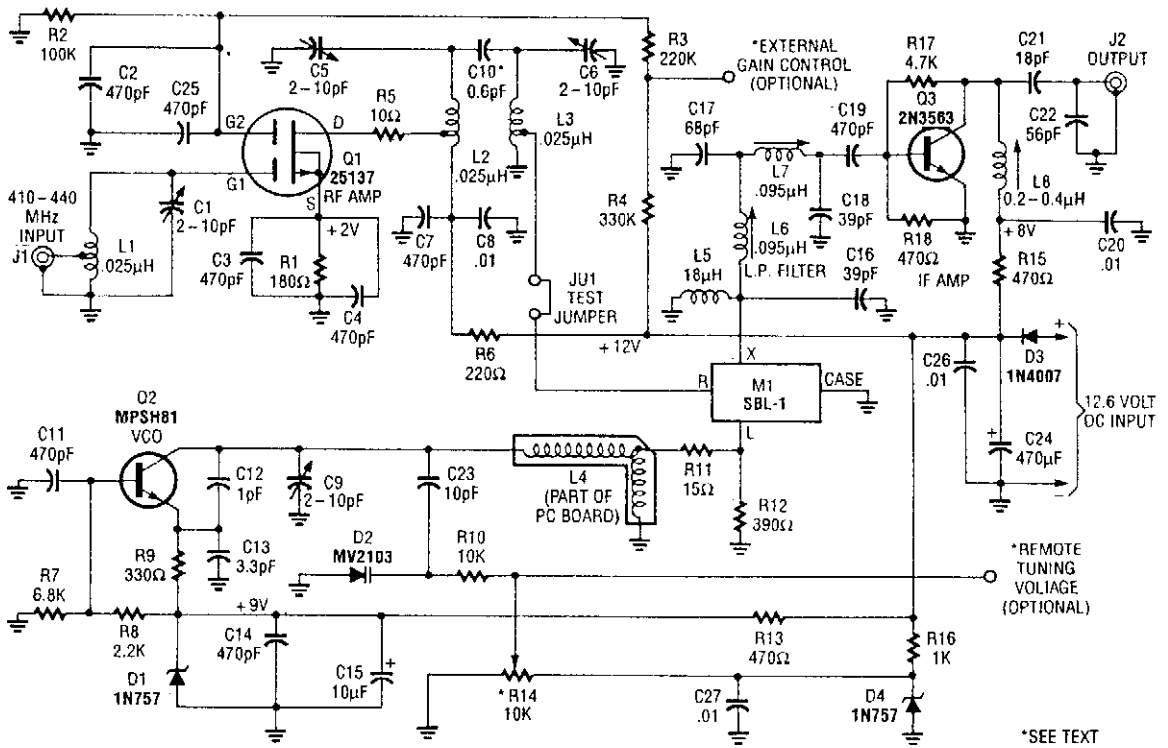

6

Amplifier Circuits

The sources of the following circuits are contained in the Sources section, which begins on page 707. The figure number in the box of each circuit correlates to the entry in the Sources section.

- Operational Transconductance Amplifier with Booster
- VCR Head Amplifier Tester
- Lowpass Amplifier
- Highpass Amplifier
- ISD 1000A Record/Playback Circuit
- Remote Amplifier
- Programmable Gain Amplifier
- Programmable Input Amplifier
- Remotely Powered Sensor Amplifier
- Tuned Amplifier
- Difference Amplifier with Wide Input Common-Mode Range
- Bandpass Amplifier
- High-Side Current-Sensing Amplifier
- High-Input Impedance ac Amplifier
- MOSFET Push-Pull Amplifier
- Low-Voltage Microphone Preamp
- Basic Logarithmic Amplifier Using Op Amp
- Crystal Tuned Amplifier

OPERATIONAL TRANSCONDUCTANCE AMPLIFIER WITH BOOSTER

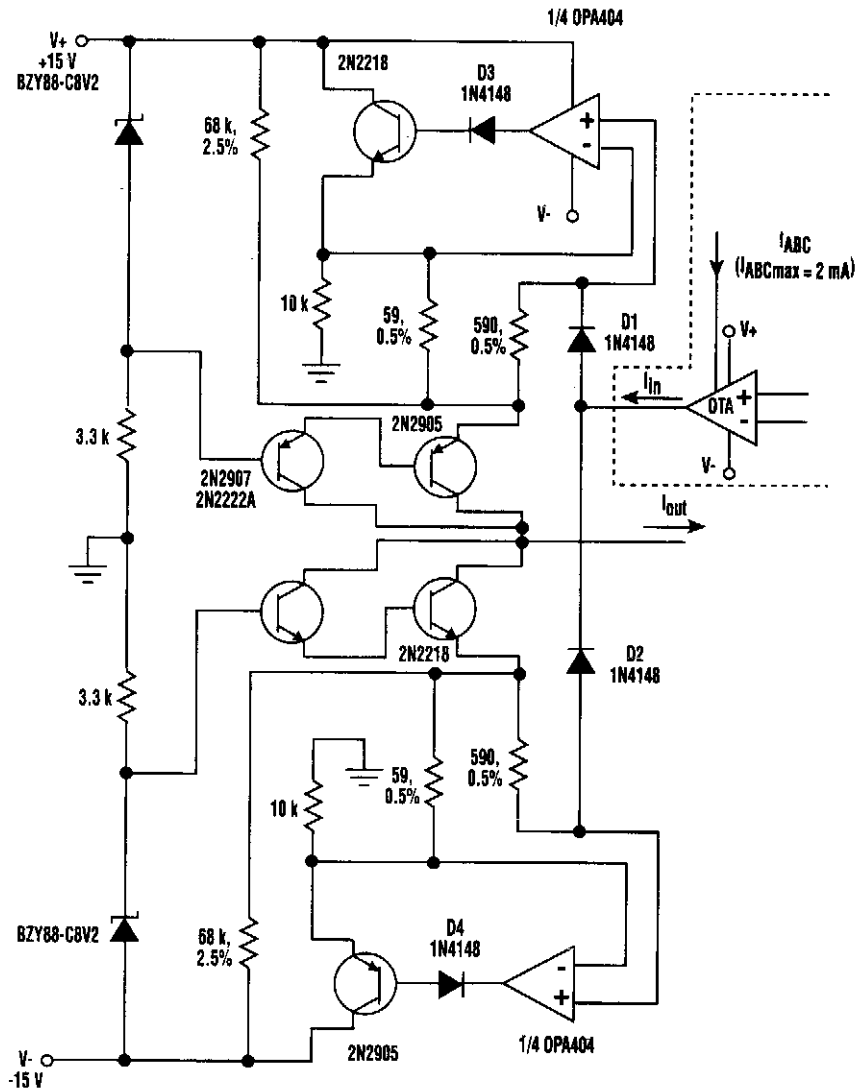

ELECTRONIC DESIGN

Fig. 6-1

Implementing a bidirectional precision current amplifier in an operational transconductance amplifier (OTA) can boost the OTA's output current. To accomplish this task, two diodes and a complementary stage are added to this otherwise simple design.

VCR HEAD AMPLIFIER TESTER

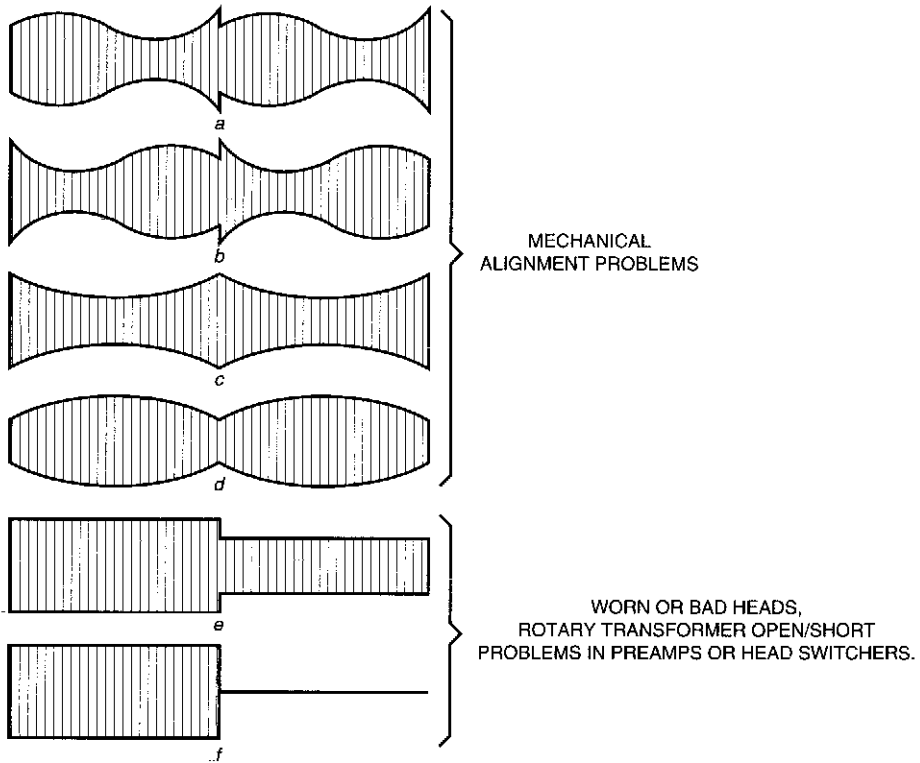

IMPROPER WAVEFORMS. Waveforms *a-d* are caused by mechanical misalignment of the tape guides. The waveforms in *e* and *f* indicate proper alignment, but show that there's a problem with either the video heads, pre-amps, or head switcher.

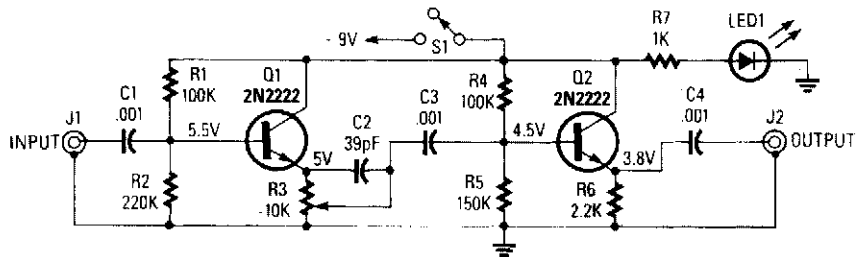

This amplifier enables you to use a signal from a working VCR to test the head amplifiers of a suspected defective VCR. The circuit is basically a video amplifier.

LOWPASS AMPLIFIER

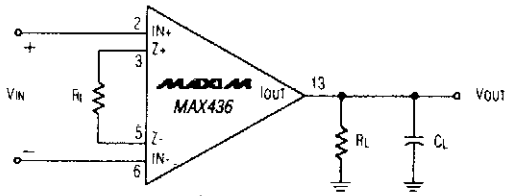

$$\text{POLE FREQUENCY} = F_p = \frac{1}{2\pi R_L C_L}$$

$$\text{PASSBAND GAIN} = K \left(\frac{R_L}{R_t} \right)$$

Lowpass Amplifier

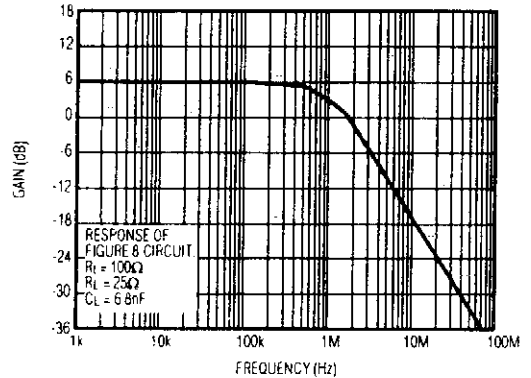

Lowpass Amplifier Gain vs. Frequency

MAXIM

Fig. 6-3

HIGHPASS AMPLIFIER

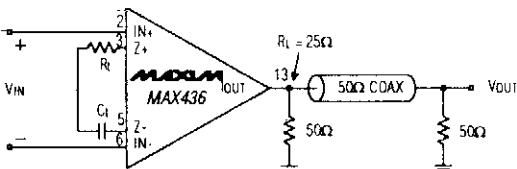

$$\text{CORNER FREQUENCY} = F_c = \frac{1}{(2\pi) (R_t) (C_t)}$$

$$\text{PASSBAND GAIN} = K \left(\frac{R_L}{R_t} \right)$$

Highpass Amplifier

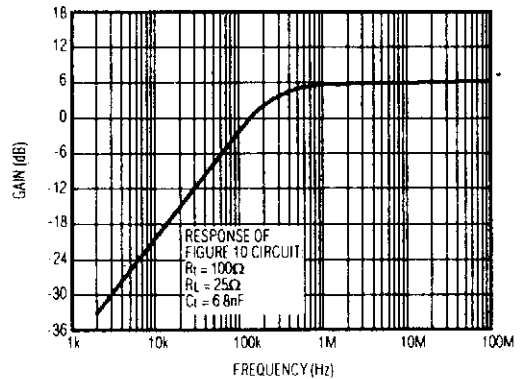

Highpass Amplifier Gain vs. Frequency

MAXIM

Fig. 6-4

ISD 1000A RECORD/PLAYBACK CIRCUIT

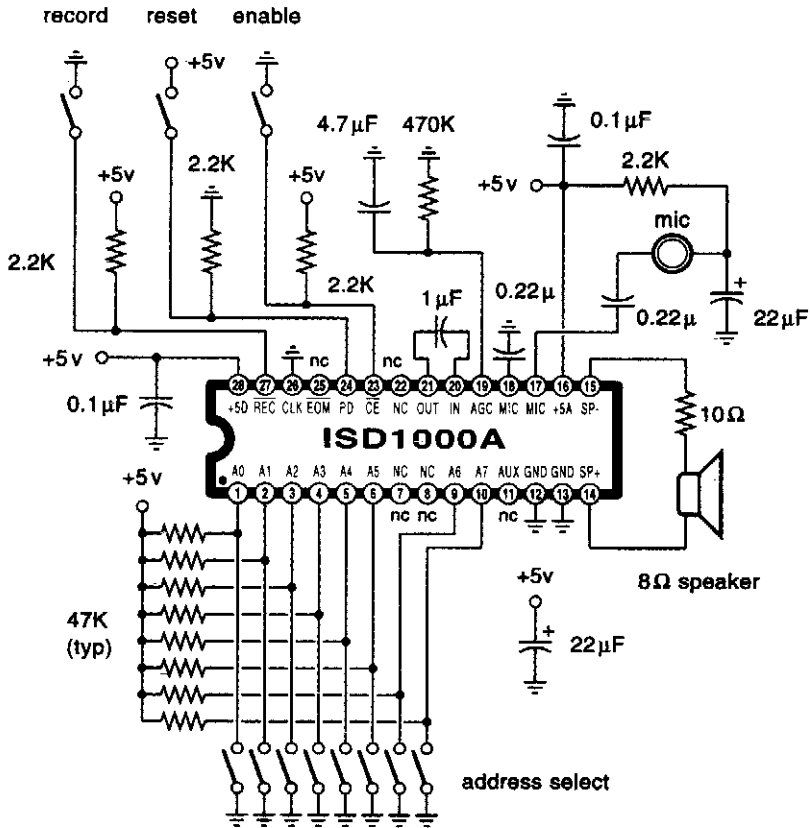

ELECTRONICS NOW

Fig. 6-5

This circuit uses the Information Storage Devices ISD1000A chip (Radio Shack P/N 276-1325).

REMOTE AMPLIFIER

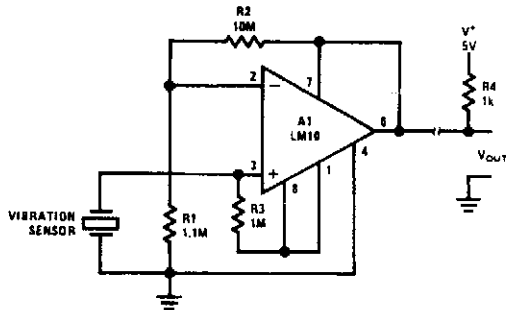

Useful for transducers and such where a single two-wire pair are the only leads available.

NATIONAL SEMICONDUCTOR

Fig. 6-6

PROGRAMMABLE GAIN AMPLIFIER

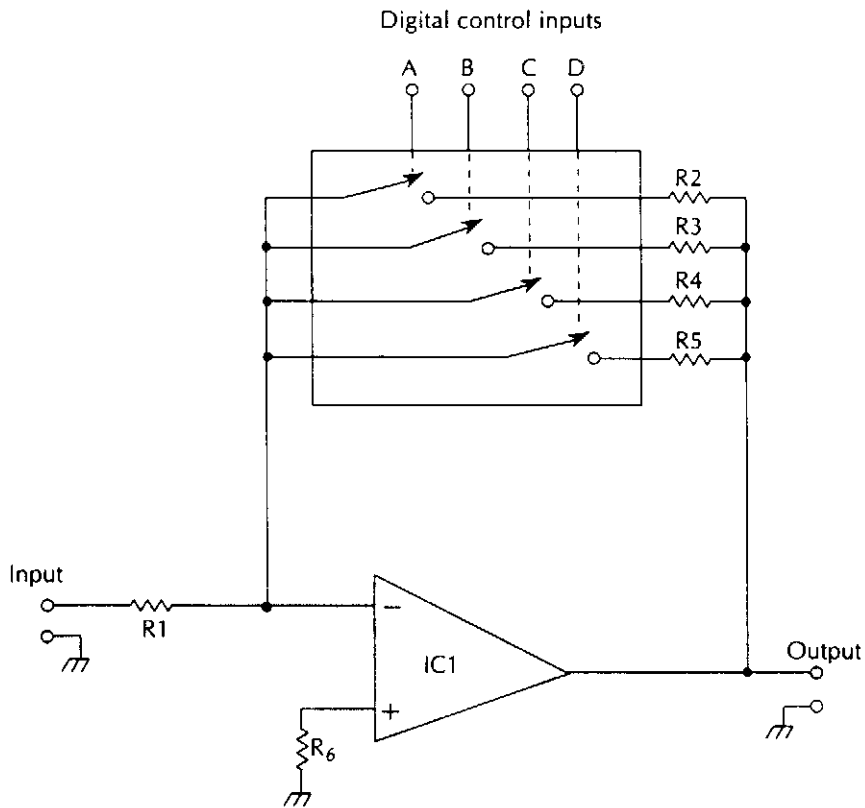

AMPLIFIERS, WAVEFORM GENERATORS & OTHER LOW-COST IC PROJECTS

Fig. 6-7

The gain of this amplifier is $-R_f/R_1$ where R_f = effective value of resistance selected by the digital R1 inputs.

- IC1 op amp
- IC2 CD4066 quad bilateral switch
- R1 1-k Ω , ¼-W 5% resistor
- R2 10-k Ω , ¼-W 5% resistor
- R3 4.7-k Ω , ¼-W 5% resistor
- R4 2.2-k Ω , ¼-W 5% resistor
- R5 1-k Ω , ¼-W 5% resistor
- R6 2.2-k Ω , ¼-W 5% resistor

PROGRAMMABLE INPUT AMPLIFIER

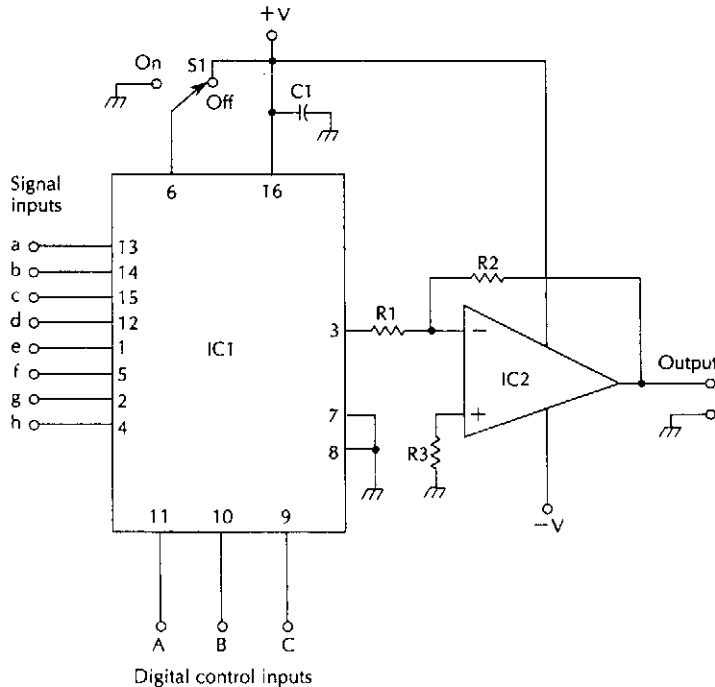

Fig. 6-8

AMPLIFIERS, WAVEFORM GENERATORS & OTHER LOW-COST IC PROJECTS

This amplifier has eight inputs selectable digitally.

IC1	CD4051 SP8T bilateral switch	R1	10-k Ω , ¼-W 5% resistor
IC2	op amp to suit application	R2	22-k Ω , ¼-W 5% resistor
C1	0.1- μ F capacitor	R3	18-k Ω , ¼-W 5% resistor
S1	SPST switch		

REMOTELY POWERED SENSOR AMPLIFIER

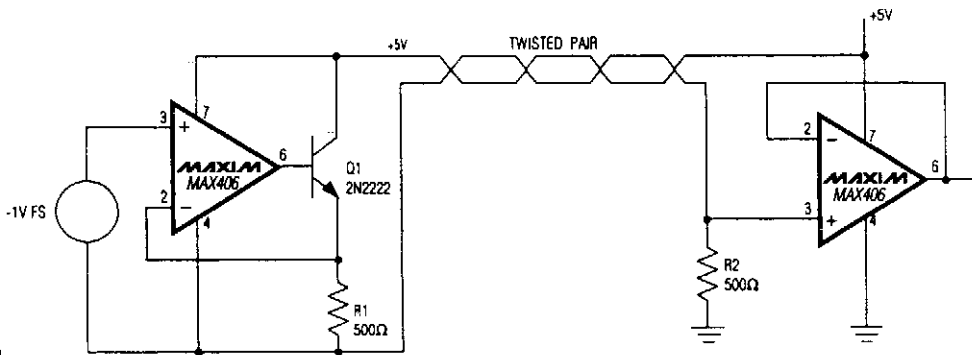
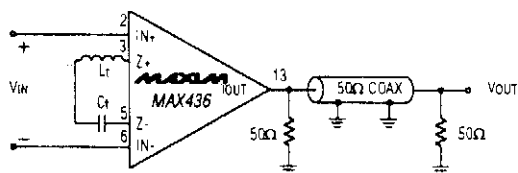

Fig. 6-9

For remote sensor applications, this circuit enables use of a single twisted pair.

TUNED AMPLIFIER



$$\text{HIGH CORNER FREQUENCY} = F_H = \frac{1}{2\pi \sqrt{L_t C_t}}$$

Q IS A FUNCTION OF PARASITICS OF L_t AND C_t

Figure A Tuned Amplifier

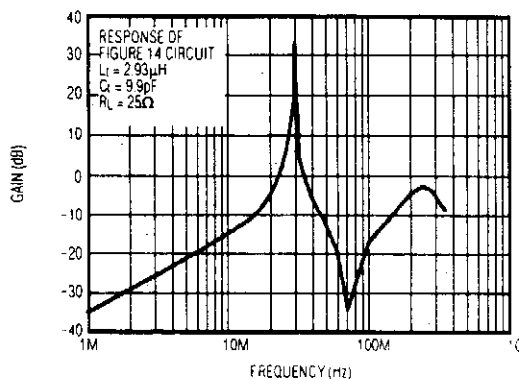

Figure B Tuned Amplifier Gain vs. Frequency

MAXIM

Fig. 6-10

This circuit is a tuned amplifier circuit, tuned to the resonant frequency of the LC transconductance network:

$$F_c = \frac{1}{2\pi \sqrt{L_t C_t}}$$

The impedance of the transconductance network is a minimum at the resonant frequency, providing maximum amplifier gain at that frequency. The Q of the amplifier is a function of the parasitic components associated with the LC network. The graph is the frequency response of the circuit, with $L_t = 2.93 \mu\text{H}$ and $C_t = 9.9 \text{ pF}$.

DIFFERENCE AMPLIFIER WITH WIDE INPUT COMMON-MODE RANGE

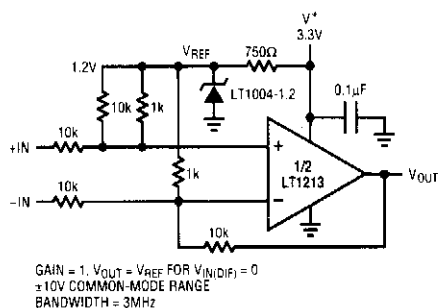

LINEAR TECHNOLOGY

Fig. 6-11

BANDPASS AMPLIFIER

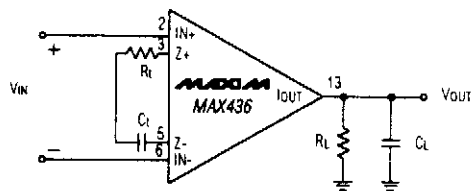

$$\text{LOW CORNER FREQUENCY} = F_L = \frac{1}{(2\pi)(R_t)(C_t)}$$

$$\text{POLE FREQUENCY} = F_P = \frac{1}{(2\pi)(R_L)(C_L)}$$

$$\text{PASSBAND GAIN} = K \left(\frac{R_L}{R_t} \right)$$

Figure A Bandpass Amplifier

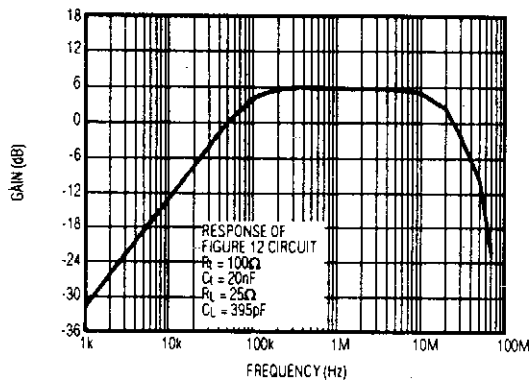

Figure B

MAXIM

Fig. 6-12

The circuit A is a bandpass amplifier, with the low corner frequency set by the impedance of the transconductance network. The high corner frequency is set by the impedance of the RC network at the amplifier output. The passband gain is $(k) \times (R_L/R_t)$. Figure B is a plot of the circuit in Figure A, with $R_t = 100 \Omega$, $C_t = 20 \text{ nF}$, $R_L = 25 \Omega$, and $C_L = 395 \text{ pF}$.

HIGH-SIDE CURRENT-SENSING AMPLIFIER

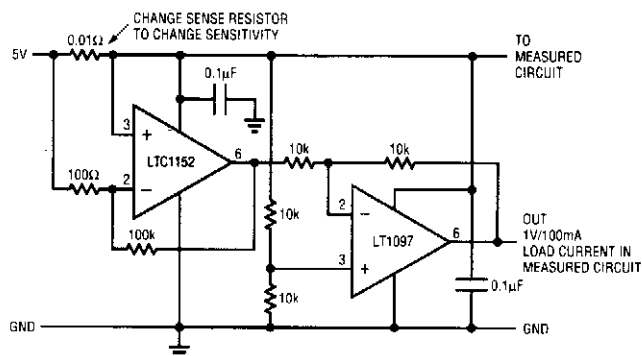

LINEAR TECHNOLOGY

Fig. 6-13

HIGH INPUT IMPEDANCE ac AMPLIFIER

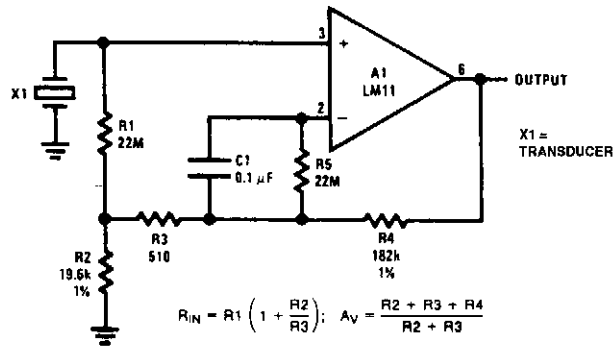

NATIONAL SEMICONDUCTOR

Fig. 6-14

This figure shows an op amp used as an ac amplifier. It is unusual in that dc bootstrapping is used to obtain high input resistance without requiring high-value resistors. In theory, this increases the output offset because the op amp offset voltage is multiplied by the resistance boost.

But when conventional resistor values are used, it is practical to include R5 to eliminate bias-current error. This gives less output offset than if a single, large resistor were used. C1 is included to reduce noise.

MOSFET PUSH-PULL AMPLIFIER

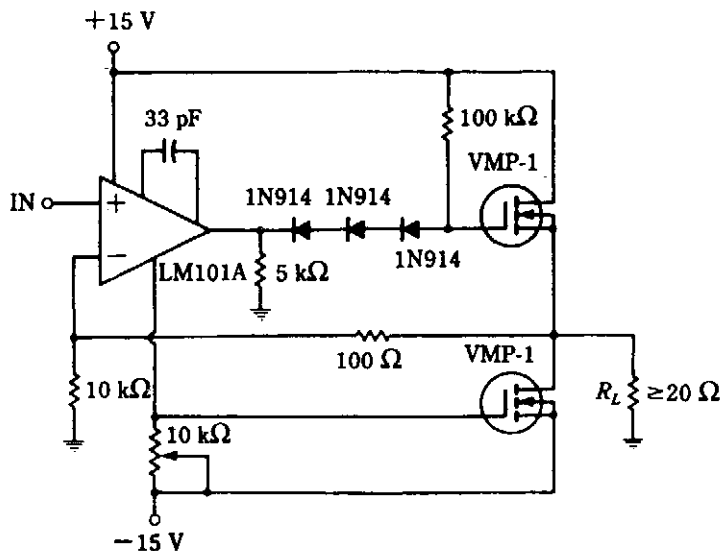

MCGRAW-HILL

Fig. 6-15

This amplifier can be used for audio or as a driver for inverter service.

LOW-VOLTAGE MICROPHONE PREAMP

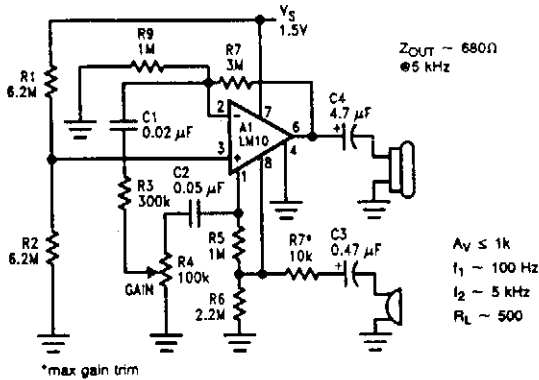

A microphone amplifier is shown. The reference, with a 500-kHz unity-gain bandwidth, is used as a preamplifier with a gain of 100. Its output is fed through a gain-control potentiometer to the op amp, which is connected for a gain of 10. The combination gives a 60-dB gain with a 10-kHz bandwidth, unloaded, and 5 kHz loaded at 500 Ω . Input impedance is 10 k Ω .

Potentially, using the reference as a preamplifier in this fashion can cause excess noise. However, because the reference voltage is low, the noise contribution, which adds root-mean-square, is likewise low. The input noise voltage in this connection is 440-500 nV/Hz, about equal to that of the op amp.

NATIONAL SEMICONDUCTOR

Fig. 6-16

BASIC LOGARITHMIC AMPLIFIER USING OP AMP

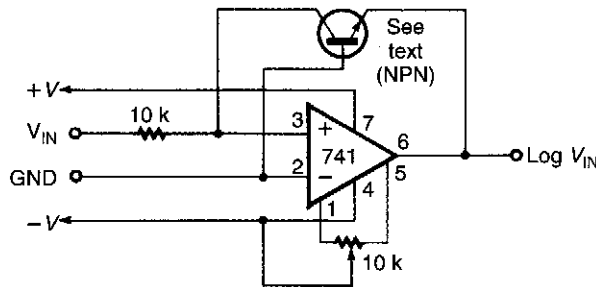

ELECTRONICS NOW!

Fig. 6-17

This logarithmic amplifier uses a single op amp. The current in the feedback loop of the op amp is equal to the current flow at the input of the op amp.

CRYSTAL TUNED AMPLIFIER

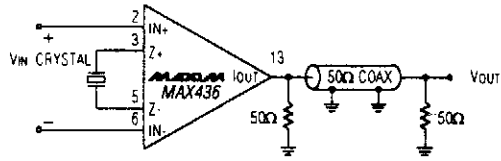

CENTER FREQUENCY = f_c = CRYSTAL FREQUENCY

Crystal Tuned Amplifier

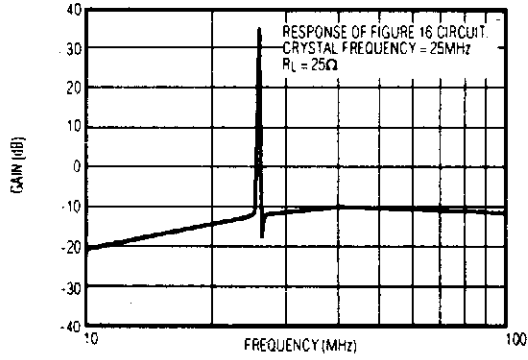

Crystal Tuned Amplifier Gain vs. Frequency

7

A/D Converter Circuits

The sources of the following circuits are contained in the Sources section, which begins on page 707. The figure number in the box of each circuit correlates to the entry in the Sources section.

High-Speed A/D Converter System
A/D Converter for PCs

HIGH-SPEED A/D CONVERTER SYSTEM

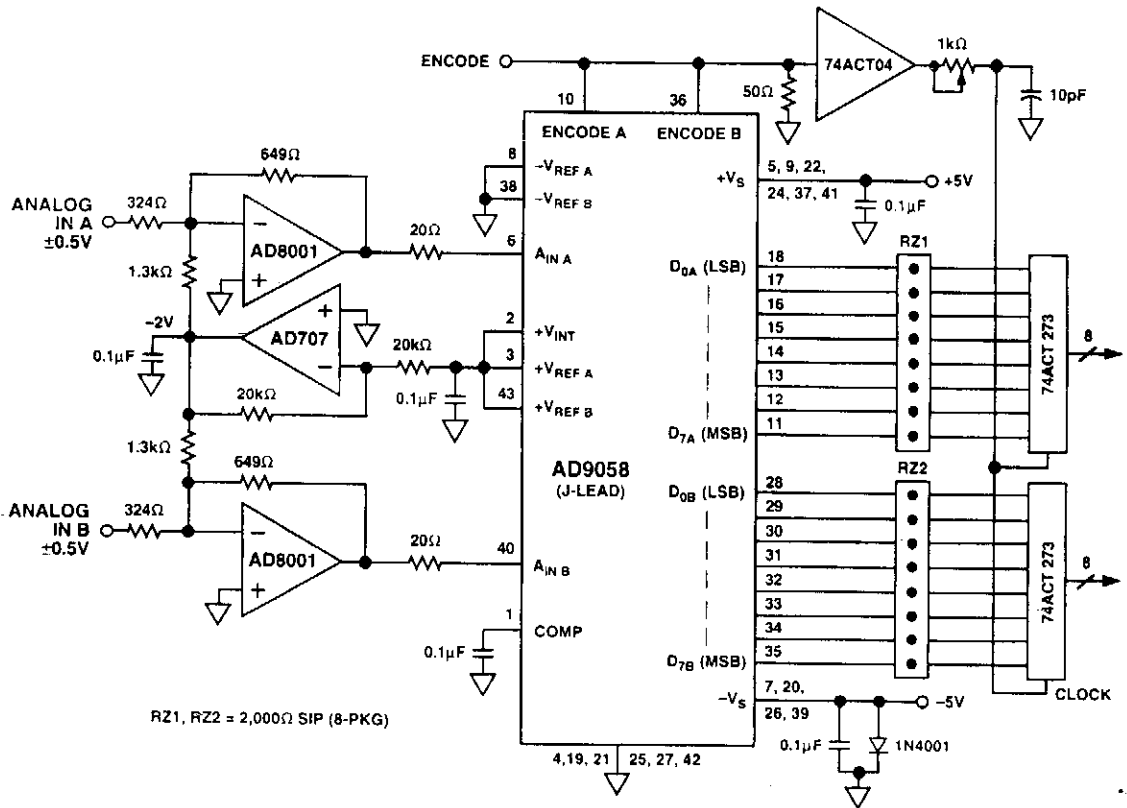

ANALOG DEVICES

Fig. 7-1

The AD8001 is well suited for driving high-speed analog-to-digital converters, such as the AD9058. The AD9058 is a dual 8-bit 50 Msp/s ADC. In the circuit shown, there are two AD8001s driving the inputs of the AD9058 which are configured for 0- to +2-V ranges. Bipolar input signals are buffered, amplified ($-2\times$), and offset (by +1.0 V) into the proper input range of the ADC. Using the AD9058's internal +2-V reference connected to both ADCs (as shown) reduces the number of external components required to create a complete data acquisition system. The 20- Ω resistors in series with ADC input are used to help the AD8001 drive the 10-pF ADC input capacitance. The two AD8001s only add 100 mW to the power consumption while not limiting the performance of the circuit.

A/D CONVERTER FOR PCs

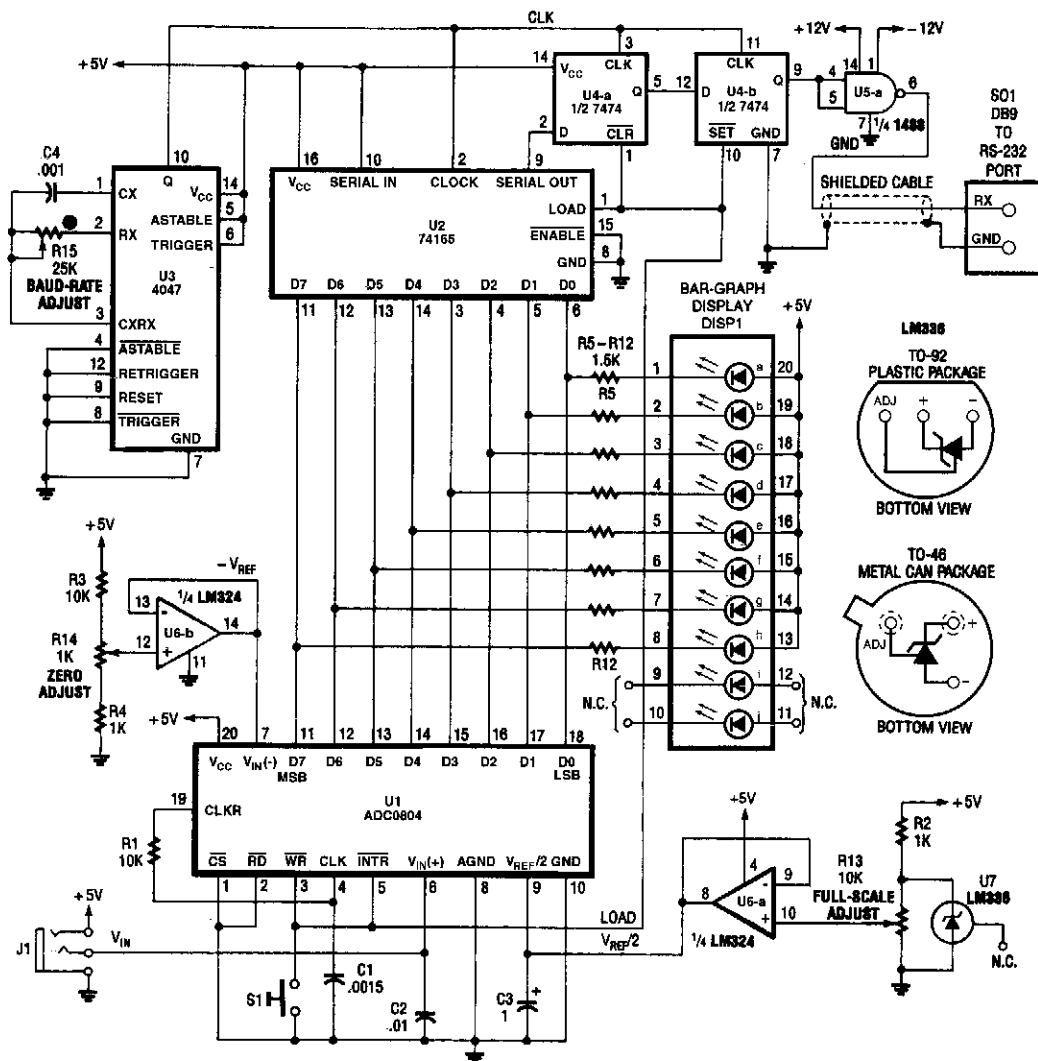

An ADC0804 A/D converter converts analog data to digital. This is fed to a 74165 8-bit shift register and converted to serial data. U3 provides a baud-rate clock. U4A and U4B are used to generate start and stop bits needed at beginning and end of each data word.

8

Antenna Circuits

The sources of the following circuits are contained in the Sources section, which begins on page 707. The figure number in the box of each circuit correlates to the entry in the Sources section.

Remote Tuned Active HF Antenna
Miniature Broadband Antenna (3 to 30 MHz)
FM Auto Radio Diversity Antenna
Tunable FM Antenna Booster
Matchbox Antenna Tuner
Antenna Tuner
Active Antenna for UHF Scanners

REMOTE TUNED ACTIVE HF ANTENNA

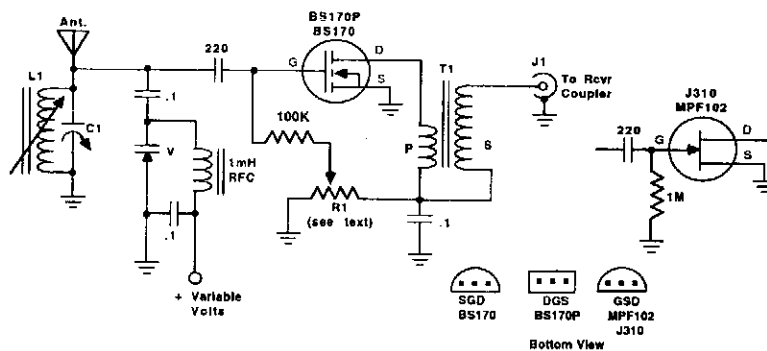
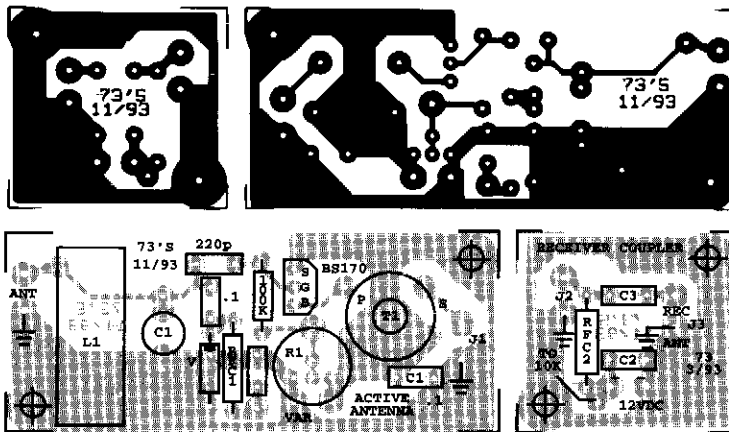
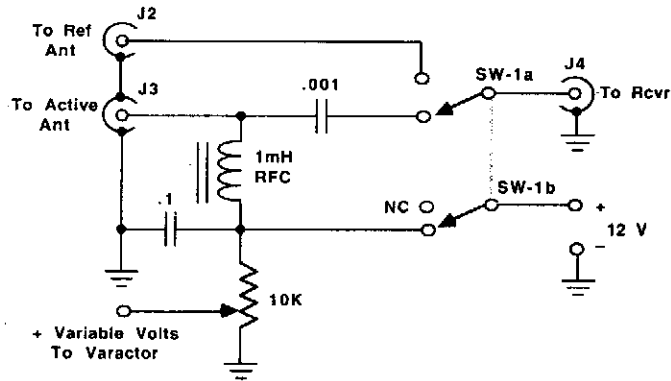

An MV1662/S varactor diode tunes this active antenna/preamplifier. R1 varies gate bias on the BS170 FET. T1 is a 3:1 toroidal winding suitable for the frequencies of interest.

MINIATURE BROADBAND ANTENNA (3 TO 30 MHz)

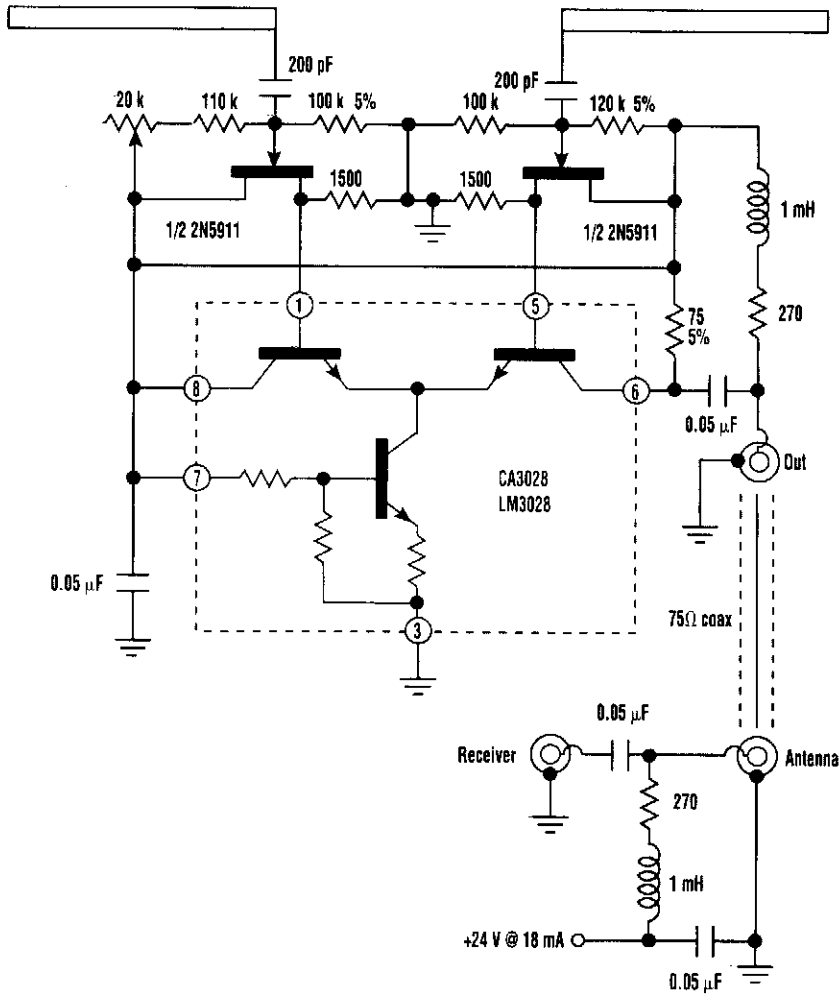

ELECTRONIC DESIGN

Fig. 8-2

A short dipole antenna and impedance converter combined together can be rotated to null out an interfering signal. The converter supplies a tremendous current gain so that the voltage appearing at the dipole's output eventually drives a 75-Ω load.

FM AUTO RADIO DIVERSITY ANTENNA

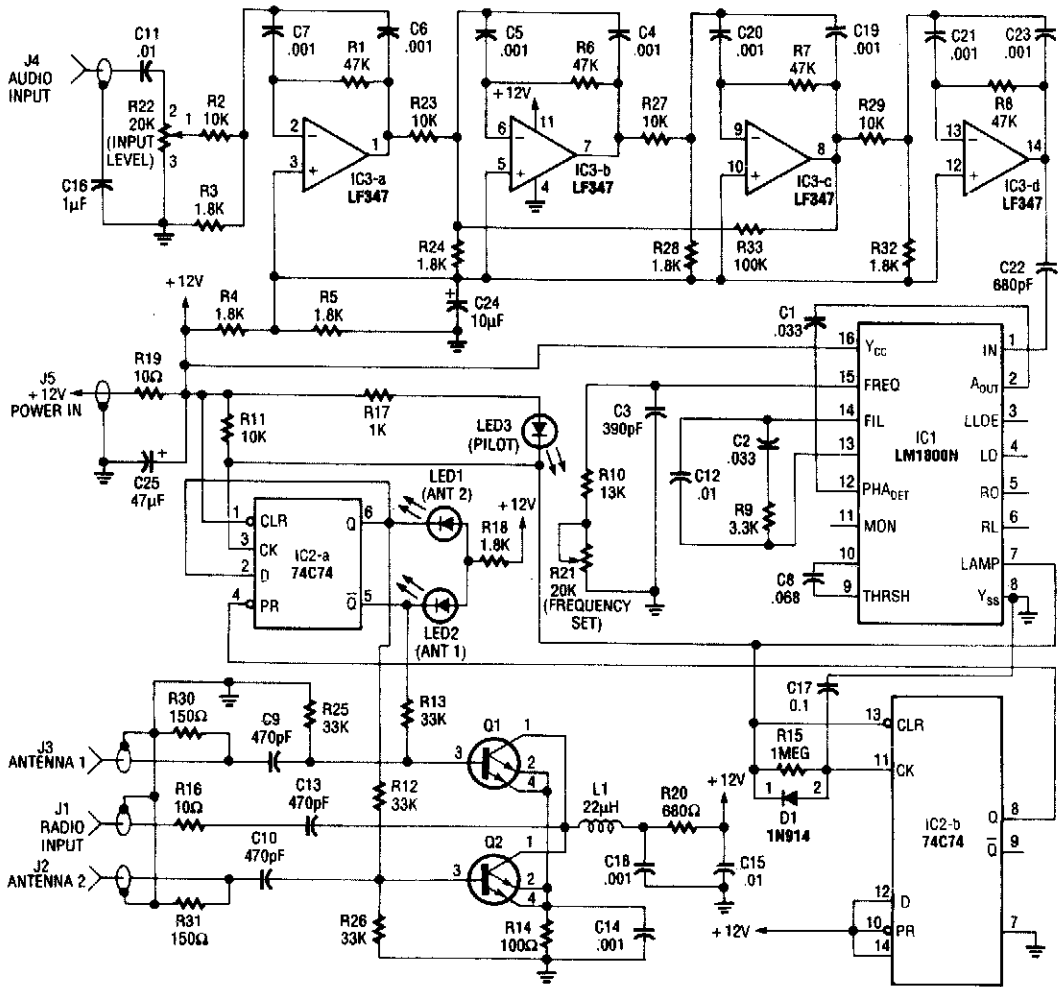

ELECTRONICS NOW

Fig. 8-3

A second antenna, installed on your vehicle as far away from the original equipment antenna as practical, provides the second FM signal. The figure is a simplified block diagram of the diversity system.

The cables from both antennas are connected to the electronic antenna switch. The 19-kHz pilot signal from the receiver's audio output is passed through a high-gain bandpass active filter, which attenuates audio programming that is much stronger than the pilot signal. After amplification, the pilot subcarrier becomes the reference frequency for a phase-locked loop (PLL) circuit. The output of the PLL locks to the 19-kHz pilot signal and functions as a subcarrier detector. When the reference frequency becomes noisy, the PLL will lose "lock" and trigger the flip-flop, whose output switches the

FM AUTO RADIO DIVERSITY ANTENNA (Cont.)

state of the electronic antenna switch. This action switches the alternate antenna into the system while disabling the original antenna.

If that second antenna is positioned for better reception, the received signal will clear, and the PLL will again lock to the subcarrier and hold the switch in that state until the pilot signal drops out again. If the second antenna does not restore the pilot signal reception after a 0.1-second delay, the primary antenna is switched back on.

When the radio is receiving AM, the absence of the 19-kHz subcarrier will also reactivate the primary antenna that is tuned to the receiver for the best AM reception.

TUNABLE FM ANTENNA BOOSTER

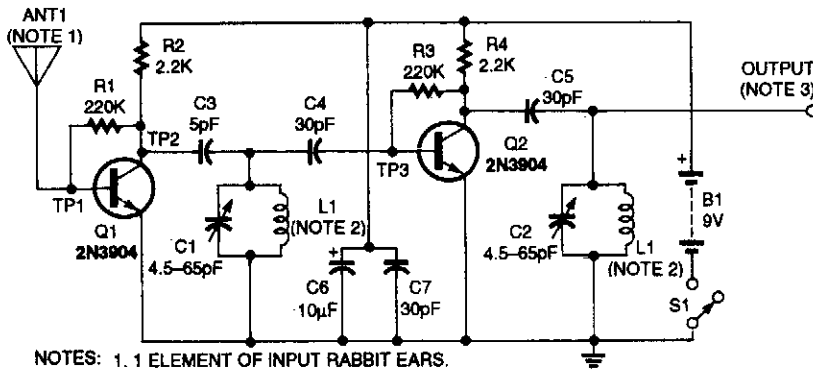

- NOTES: 1. 1 ELEMENT OF INPUT RABBIT EARS.
2. SEE TEXT FOR WINDING INSTRUCTIONS
3. TO ANTENNA OF FM RECEIVER
4. VOLTAGES AT TEST POINTS: TP1=0.68V, TP2=3.85V, TP3=0.68V.

ELECTRONICS NOW

Fig. 8-4

This two-transistor amplifier circuit with tunable tank circuits boosts the distant FM signals. Coils L1 and L2 are 1½ turns #20 AWG bail tinned wire wound around a ⅜" diameter mandrel.

MATCHBOX ANTENNA TUNER

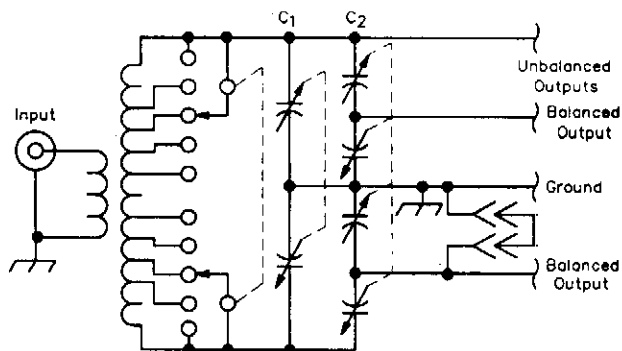

QST

Fig. 8-5

C1 is a split stator capacitor and C2 is a dual differential capacitor. The top unbalanced output connection is used for high-impedance unbalanced loads, and the other is used for low-impedance unbalanced loads. In the latter case, the unused balanced load connection is grounded.

ANTENNA TUNER

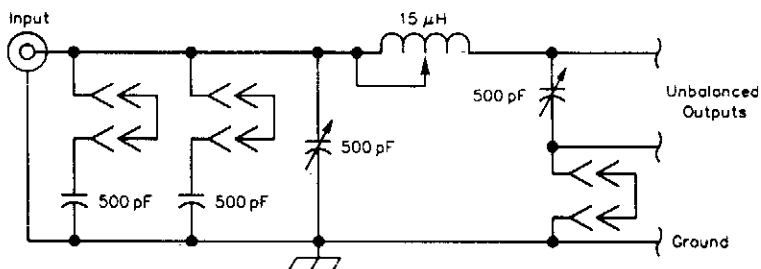

QST

Fig. 8-6

This is a circuit diagram of the Collins Model 180S-1 antenna tuner. Three unbalanced configurations are available, two of which form an L-network and the other is a π -network. The tuning range is impressive.

ACTIVE ANTENNA FOR UHF SCANNERS

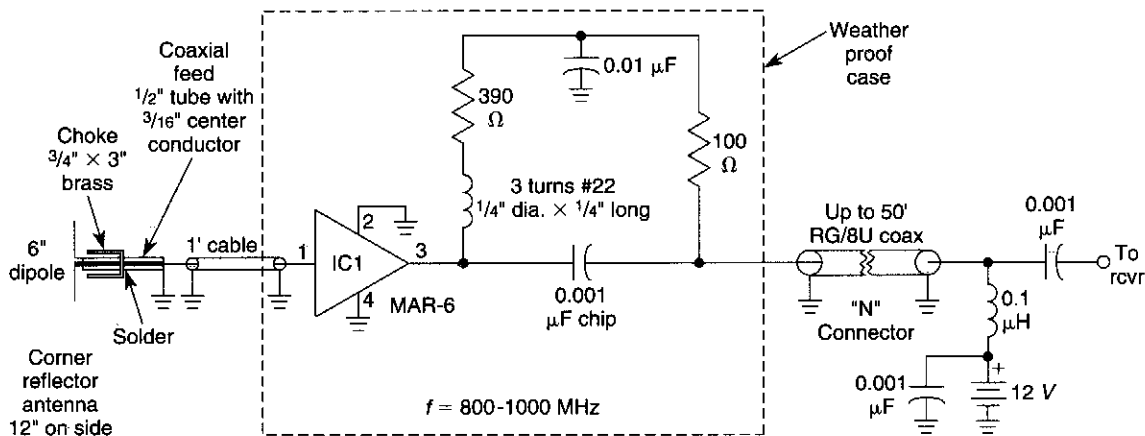

WILLIAM SHEETS

Fig. 8-7

This active antenna is a $\frac{1}{2}$ -wave dipole mounted in a $12" \times 12" \times 12"$ 90° corner reflector. A built-in active preamp IC1, fed dc through the RF coaxial line, provides 15 dB gain at 900 MHz to offset cable losses. This provides superior reception for scanners covering the 800- to 1000-MHz range.

9

Attenuator Circuits

The sources of the following circuits are contained in the Sources section, which begins on page 707. The figure number in the box of each circuit correlates to the entry in the Sources section.

Switchable Power Attenuator
Variable Voltage Attenuator

SWITCHABLE POWER ATTENUATOR

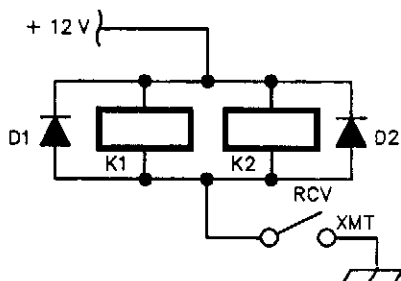
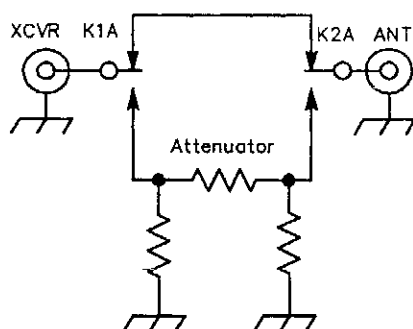

QST

Fig. 9-1

Schematic diagram of a switchable power attenuator that can be used to reduce the power output of transmitters that don't have ALC lines.

Values for 10 and 20 dB:

10 dB: $R_1 = R_3 = 91 \Omega$
 $R_2 = 75 \Omega$ nearest standard values

20 dB: $R_1 = R_3 = 62 \Omega$
 $R_2 = 240 \Omega$ nearest standard values

Note: R1 must handle the largest share of the input power, and R2 somewhat less. This depends on attenuation selected.

VARIABLE VOLTAGE ATTENUATOR

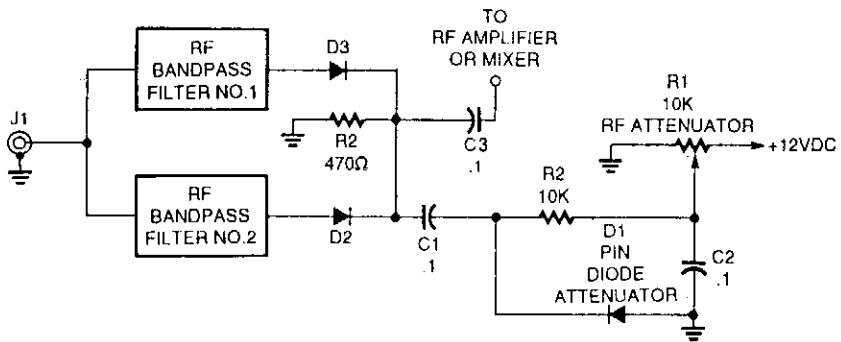

POPULAR ELECTRONICS

Fig. 9-2

The front-end of this circuit is a bank of selectable bandpass filters. The output of the filter banks are shunted to ground via capacitor (C1) and PIN diode (D1). The PIN diode acts like an electronically variable resistor. The resistance across the diode's terminals is a function of the applied bias voltage. This voltage, hence the degree of attenuation of the RF signal, is proportional to the setting of potentiometer R1. The series resistor (R2) is used to limit the current when the diode is forward biased. This step is necessary because the diode has a very low resistance when a certain rather low potential is exceeded.

10

Audio Signal Amplifier Circuits

The sources of the following circuits are contained in the Sources section, which begins on page 707. The figure number in the box of each circuit correlates to the entry in the Sources section.

Vacuum Tube Audio Amplifier
Micropower Linear Amplifier
NB FM Audio Amplifier
Two-Transistor Audio Amplifier
Personal Stereo Audio Amp
Transistor RIAA Preamp for Magnetic Phone Cartridges
Dynamic Microphone Preamp
Balanced Microphone Preamplifier
RIAA Line Amplifier/Driver
Single-Ended HI-Z Microphone Preamp
Low-Level Audio Amplifier
Simple 20-dB Gain Audio Amplifier
High-Gain Dynamic Microphone Preamplifier
FET Phono Cartridge Preamp
Simple High-Gain Audio Amplifier
RIAA Preamplifier
Basic Complementary Class-AB Single-Supply Amplifier
High-Impedance Microphone Input Circuit
Electronic-Ear Low-Noise Audio Amplifier (for Parabolic Dish Mikes)

VACUUM TUBE AUDIO AMPLIFIER

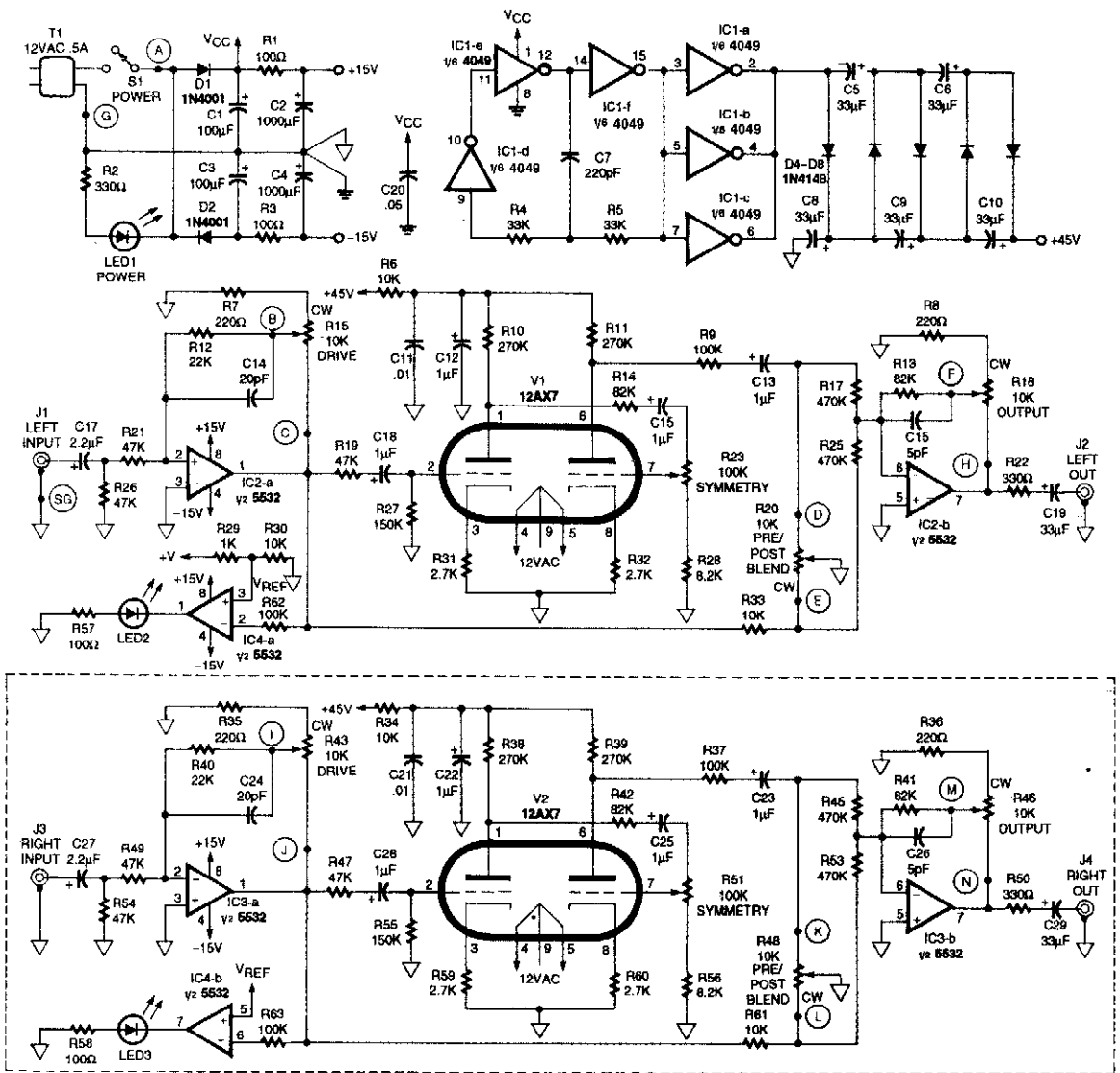

VACUUM TUBE AUDIO AMPLIFIER (Cont.)

This schematic is for a tubehead amplifier. The output from transformer T1 is positive half-wave ac rectified by D1 and filtered by C1, C2, and R1 for a +15-V supply. A -15-V supply is available from D2, C3, C4, and R3. The plate supply for the 12AX7 tubes is produced by a voltage multiplier.

Some listeners prefer the sound of a vacuum-tube audio system. Although this is rather subjective and a personal preference, this circuit can be used to simulate the "tube sound" preferred by these listeners.

MICROPOWER LINEAR AMPLIFIER

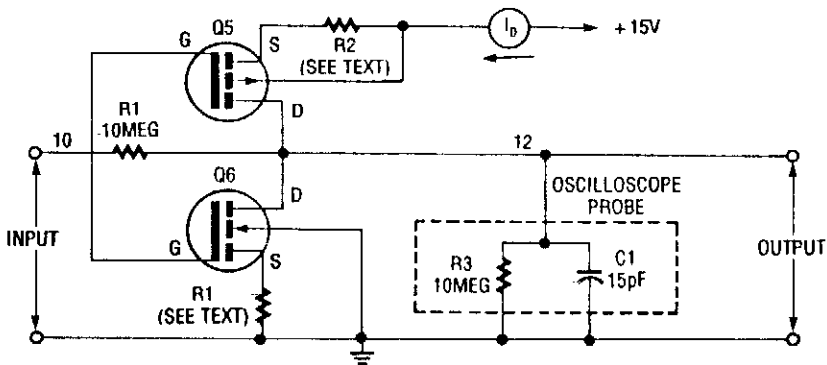

ELECTRONICS NOW

Fig. 10-2

This circuit, based on the inverter in the CD4007UB CMOS linear amplifier, shows a method for reducing drain current.

NB FM AUDIO AMPLIFIER

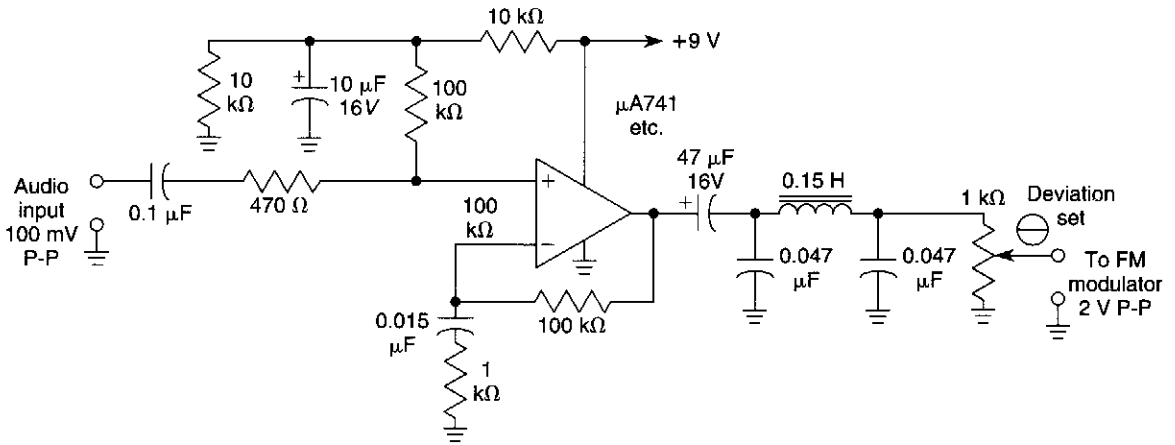

WILLIAM SHEETS

Fig. 10-3

This audio system amplifies, limits, and filters an audio voice signal for use with an FM modulator or VCO. It has pre-emphasis of 6-dB/octave 300–3000 Hz. Almost any suitable op amp can be used.

TWO-TRANSISTOR AUDIO AMPLIFIER

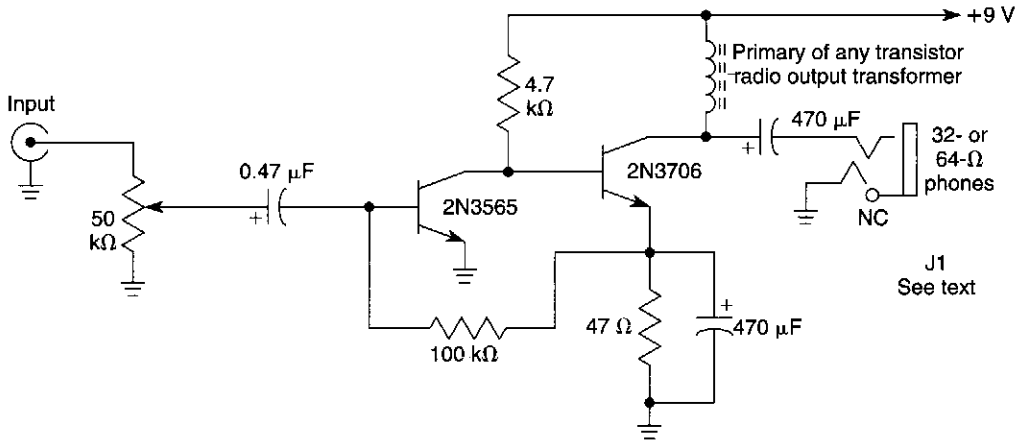

WILLIAM SHEETS

Fig. 10-4

This is a general-purpose audio amplifier for driving a pair of stereo earphones in monaural mode. Two can be used for stereo. In this case, ground the center top of the earphone (sleeve of J1).

PERSONAL STEREO AUDIO AMP

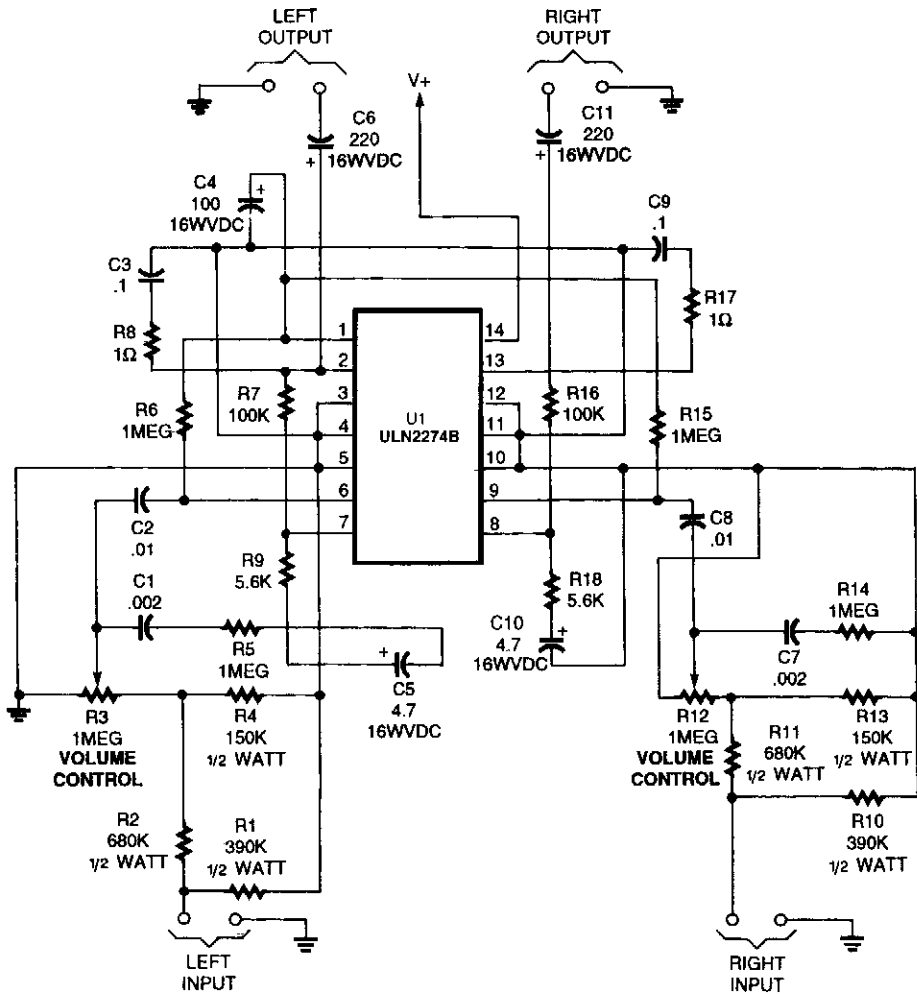

You can make your personal stereo do double duty as a small room stereo by adding this 2-watt amplifier.

TRANSISTOR RIAA PREAMP FOR MAGNETIC PHONE CARTRIDGES

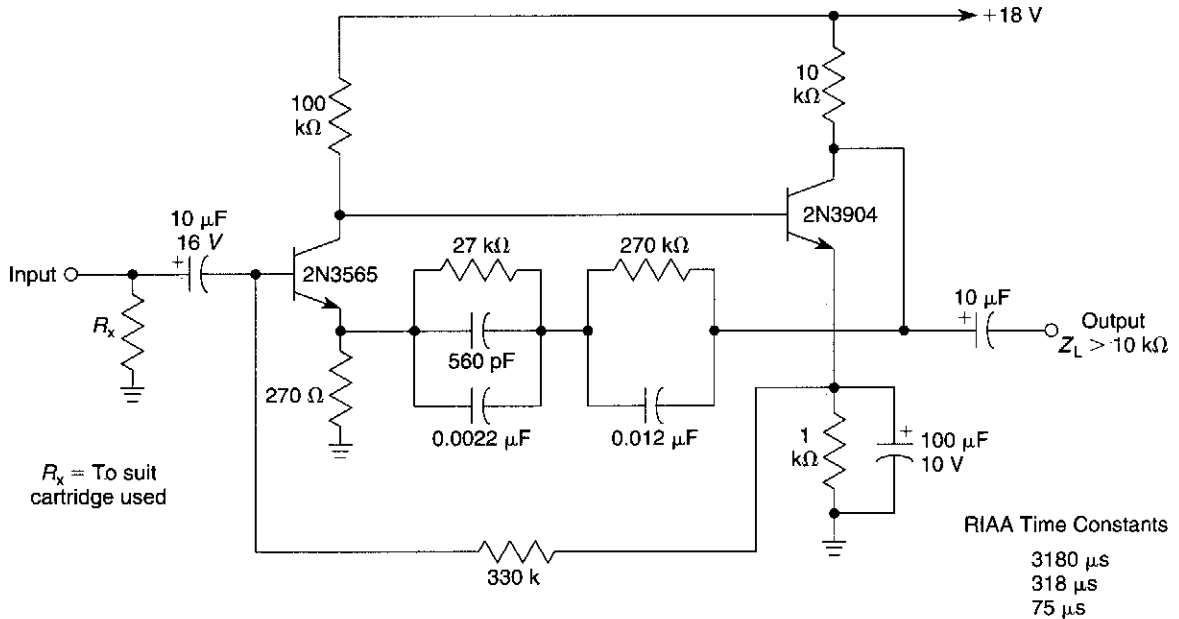

WILLIAM SHEETS

Fig. 10-6

This two-transistor circuit has around 40 dB (midband) gain at 1 kHz. A magnetic cartridge is used as a source.

DYNAMIC MICROPHONE PREAMP

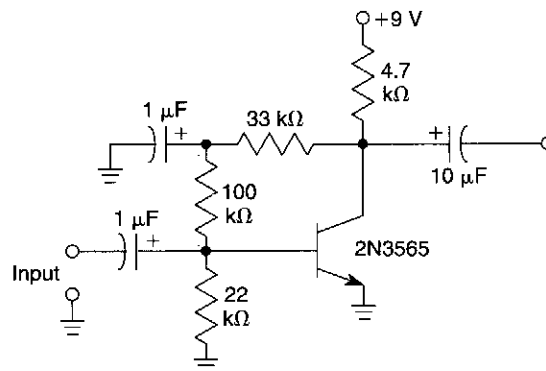

WILLIAM SHEETS

Fig. 10-7

This preamplifier provides 40- to 43-dB gain when used with a low-impedance ($< 1 \text{ k}\Omega$) dynamic microphone.

PERSONAL STEREO AUDIO AMP

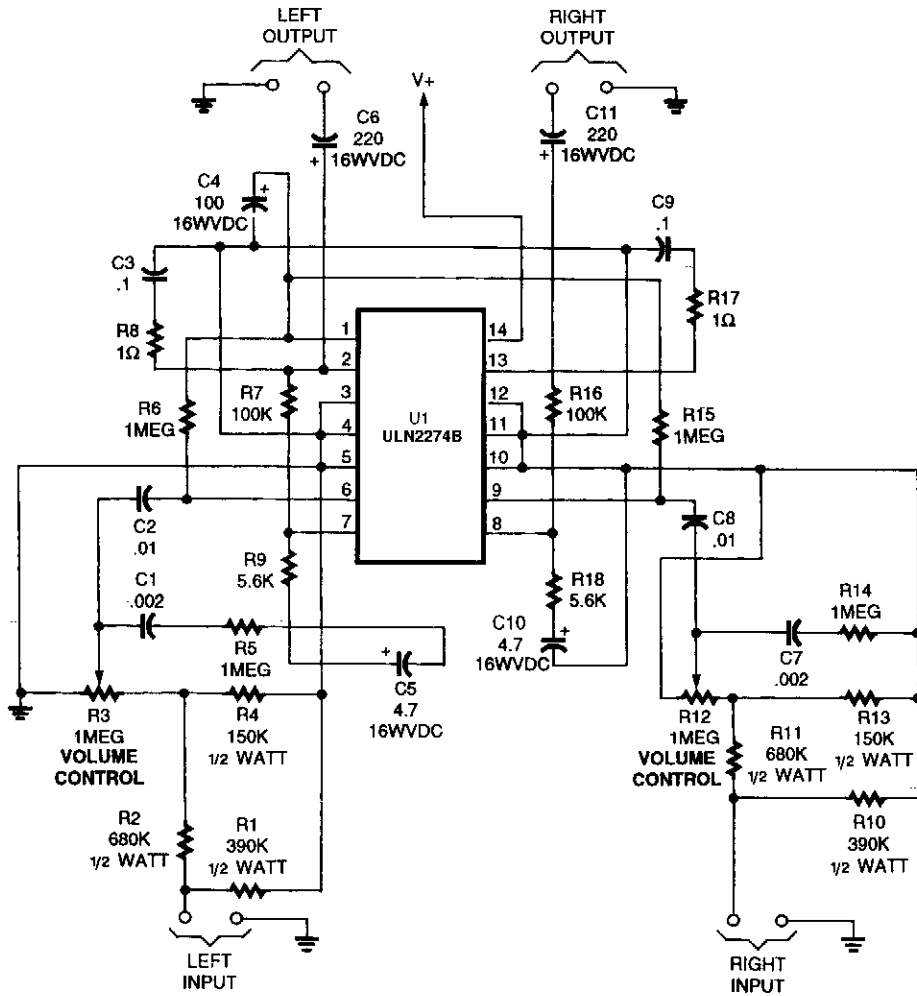

You can make your personal stereo do double duty as a small room stereo by adding this 2-watt amplifier.

BALANCED MICROPHONE PREAMPLIFIER

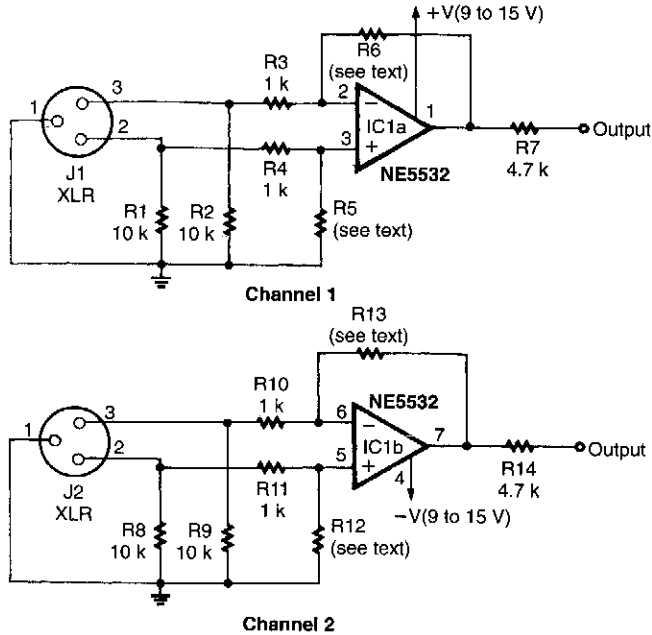
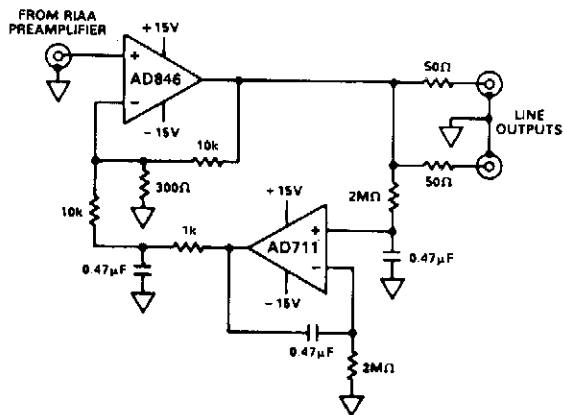

Fig. 10-8

ELECTRONICS NOW

A balanced input for microphones can solve hum and noise pickup problems. R6 and R13 should equal R5 and R12, respectively. Typical values would be 10 kΩ to 22 kΩ.

RIAA LINE AMPLIFIER/DRIVER



Two op amps by Analog Devices are used in this audio line amplifier, which is suitable for interfacing with an RIAA preamplifier.

ANALOG DEVICES

Fig. 10-9

SINGLE-ENDED HI-Z MICROPHONE PREAMP

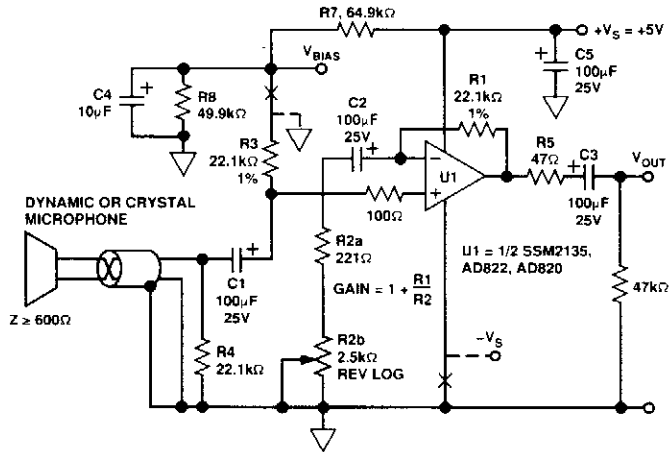

ANALOG DEVICES

Fig. 10-10

This low noise circuit works on a +5-V supply. Gain range is 20 to 40 dB and bandwidth is 20 kHz with the AD820. THD is 0.05% with 1 V RMS into a 2-kΩ load. Noise output with the input shorted is less than 200 μV.

LOW-LEVEL AUDIO AMPLIFIER

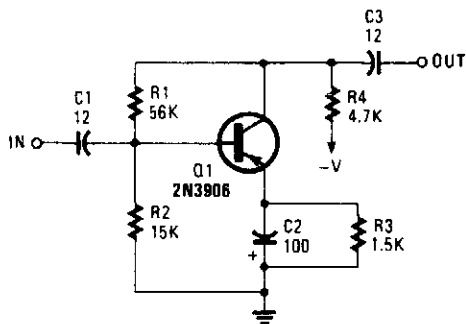

POPULAR ELECTRONICS

Fig. 10-11

SIMPLE 20-dB GAIN AUDIO AMPLIFIER

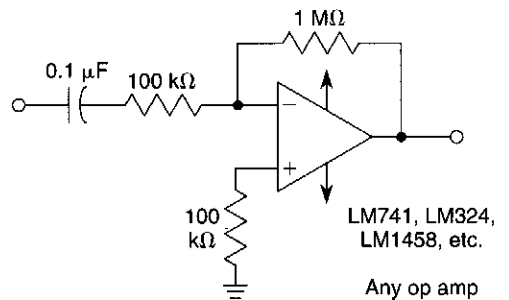

WILLIAM SHEETS

Fig. 10-12

HIGH-GAIN DYNAMIC MICROPHONE PREAMPLIFIER

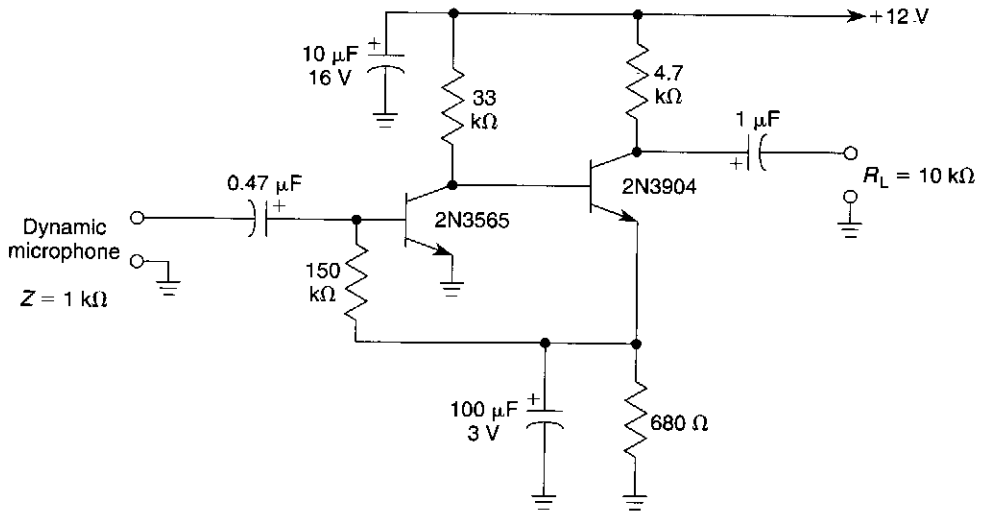

WILLIAM SHEETS

Fig. 10-13

This microphone preamplifier is capable of about 70 dB or more gain at audio frequencies. Its gain is approximately equal to the product of the h_{fe} of both transistors times the ratio of the load resistance to the input resistance of the preamp. As an approximation, these resistances are usually similar in value (≈ 2 to 5 k Ω) for most applications, so this ratio can be taken as unity.

FET PHONO CARTRIDGE PREAMP

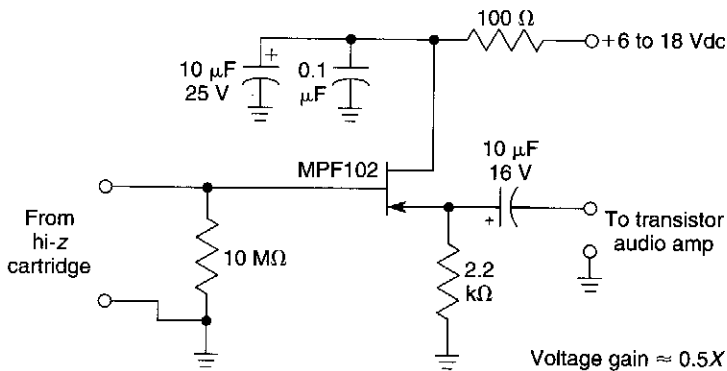

WILLIAM SHEETS

Fig. 10-14

A high- Z phono cartridge can be matched to a low- Z amplifier with this circuit. The FET provides a current gain of over 1000 \times and a voltage gain of about 0.5 \times .

SIMPLE HIGH-GAIN AUDIO AMPLIFIER

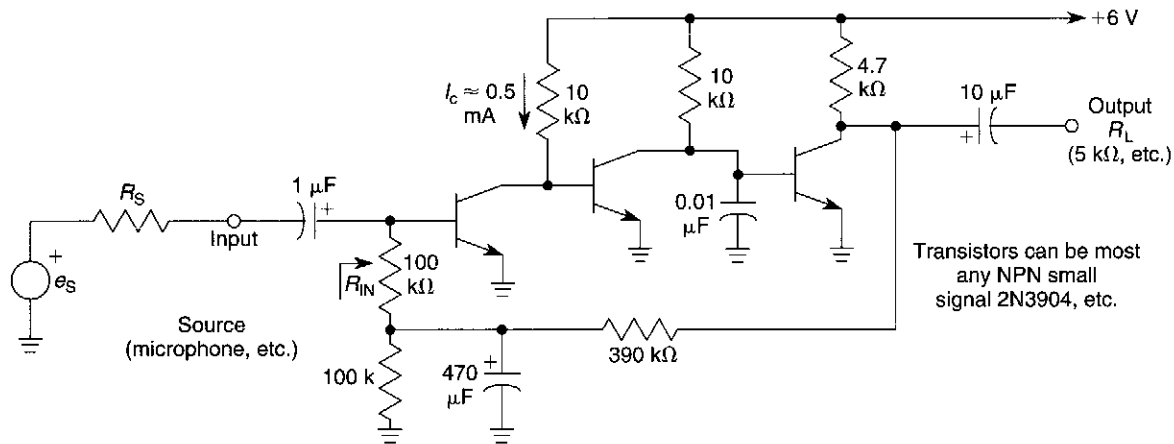

WILLIAM SHEETS

Fig. 10-15

This amplifier has a very high gain in the audio range and is approximately the product of the current gains of the three transistors multiplied by the ratio of R_L to $(R_{IN} + R_S)$. R_{IN} is approximately to:

$$(\beta_{Q1} + 1) \frac{(26)}{I_{EQ1}}$$

RIAA PREAMPLIFIER

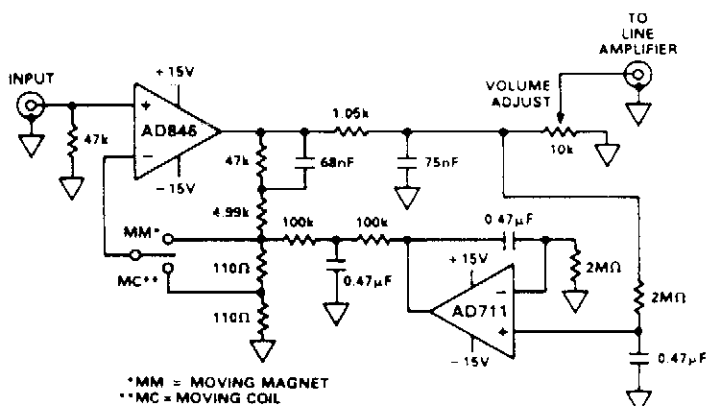

ANALOG DEVICES

Fig. 10-16

This preamp for RIAA phone use uses two op amps by Analog Devices. A switch selects compensation for moving magnet or moving coil pickups.

BASIC COMPLEMENTARY CLASS-AB SINGLE-SUPPLY AMPLIFIER

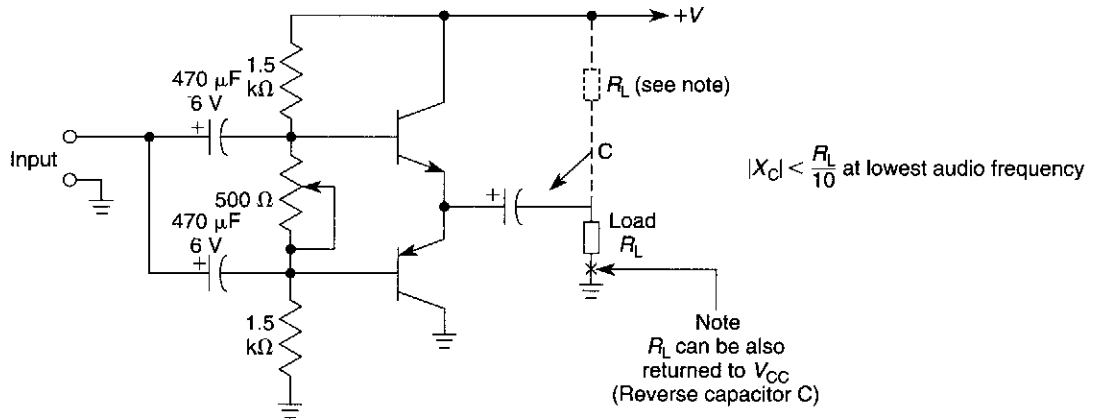

WILLIAM SHEETS

Fig. 10-17

HIGH-IMPEDANCE MICROPHONE INPUT CIRCUIT

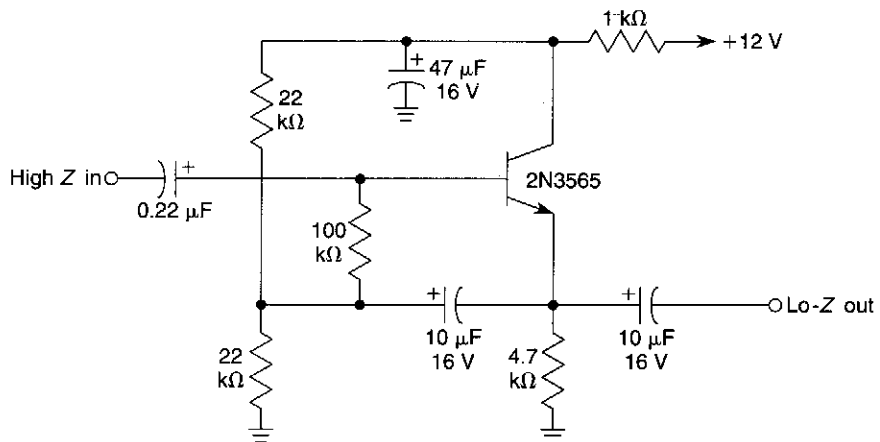

WILLIAM SHEETS

Fig. 10-18

This input circuit will enable use of a high-impedance microphone where a low-impedance microphone would be needed.

ELECTRONIC-EAR LOW-NOISE AUDIO AMPLIFIER (FOR PARABOLIC DISH MIKES)

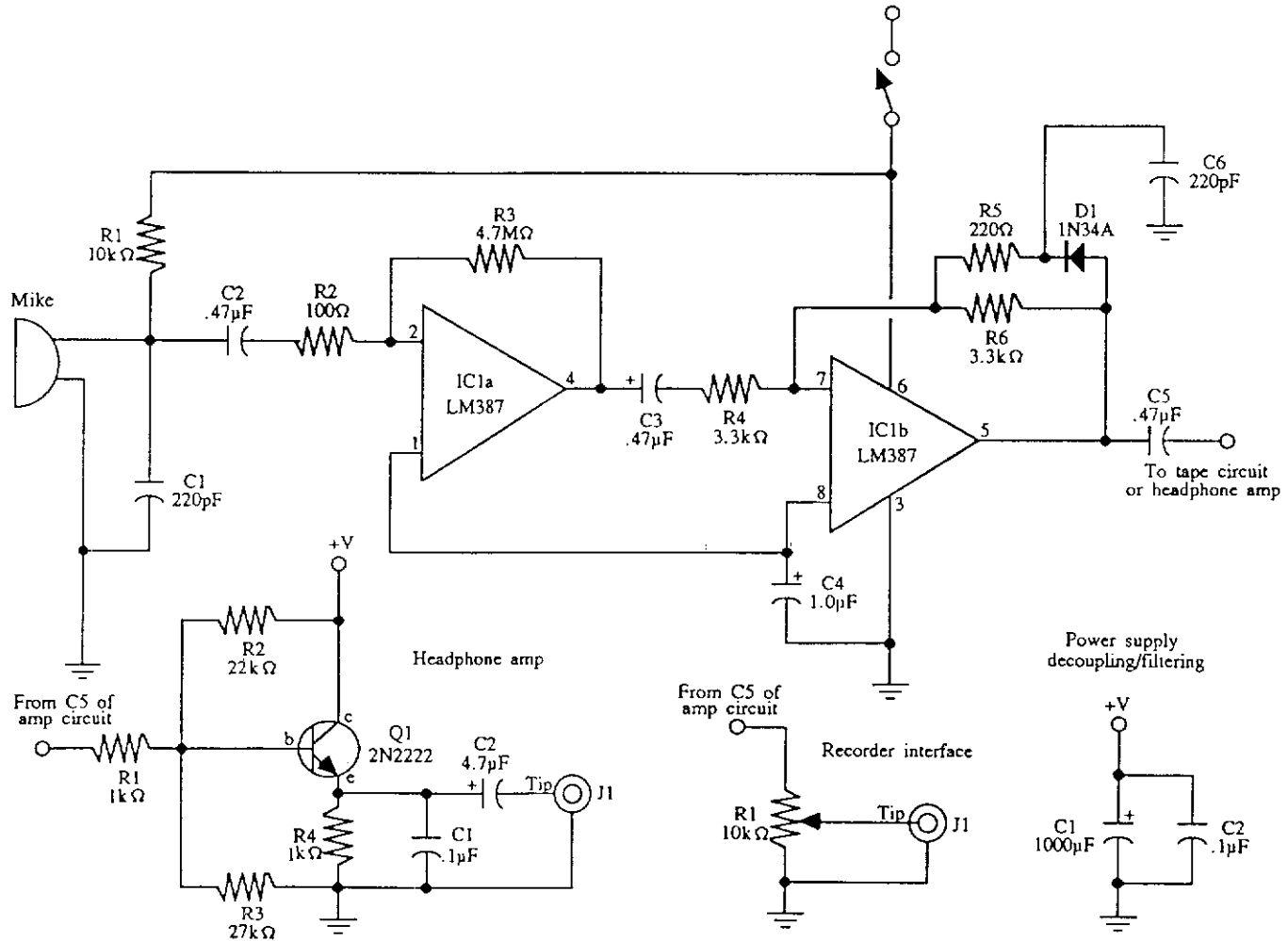

MCGRAW-HILL

Fig. 10-19

Use this circuit with a parabolic reflector microphone for eavesdropping on distant sounds.

11

Audio Power Amplifier Circuits

The sources of the following circuits are contained in the Sources section, which begins on page 707. The figure number in the box of each circuit correlates to the entry in the Sources section.

Audio Power Amplifier, 1.5 W, 12 V
Parallel Power Op Amps
10-Watt Audio Amplifier
Power Bridge Amplifier with Single-Ended Output
Line-Operated Audio Amplifier
Basic Complementary Class-AB Power Amplifier
Simple Vacuum Tube Amplifier
Power Supply for Vacuum Tube Amplifier
16-W Bridge Amplifier
RFI-Proof Audio Power Amplifier
Basic Quasi-Complementary Power Amplifier with Split Power Supplies
RIAA Phono Amplifier
Basic Quasi-Complementary Power Amplifier Circuit
Phone Amp
80-Watt IC Audio Amplifier
Basic Complementary Power Amplifier Circuit
General-Purpose AF Amplifier
Bridge Connection of Two Power Op Amps
90-V 10-A High-Power Amplifier
Mini-Megaphone

AUDIO POWER AMPLIFIER, 1.5 W, 12 V

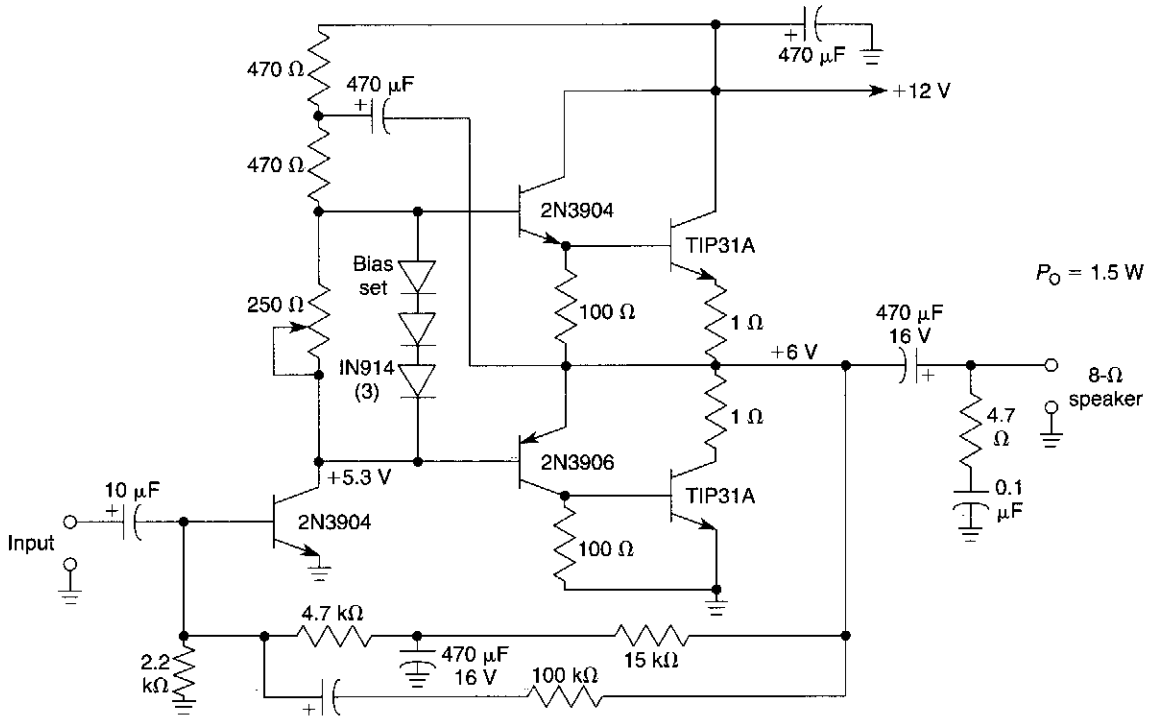

WILLIAM SHEETS

Fig. 11-1

Although ICs have largely replaced circuits such as this, this circuit still finds use where the flexibility of a discrete device design is desirable. Parts are easy to obtain and the problem of IC obsolescence is eliminated. The TIP31A can be heatsinked to a small metal heatsink, if desired.

PARALLEL POWER OP AMPS

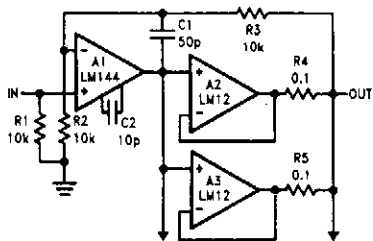

The power amplifiers, A2 and A3, are wired as followers and connected in parallel with the outputs coupled through equalization resistors.

NATIONAL SEMICONDUCTOR

Fig. 11-2

10-WATT AUDIO AMPLIFIER

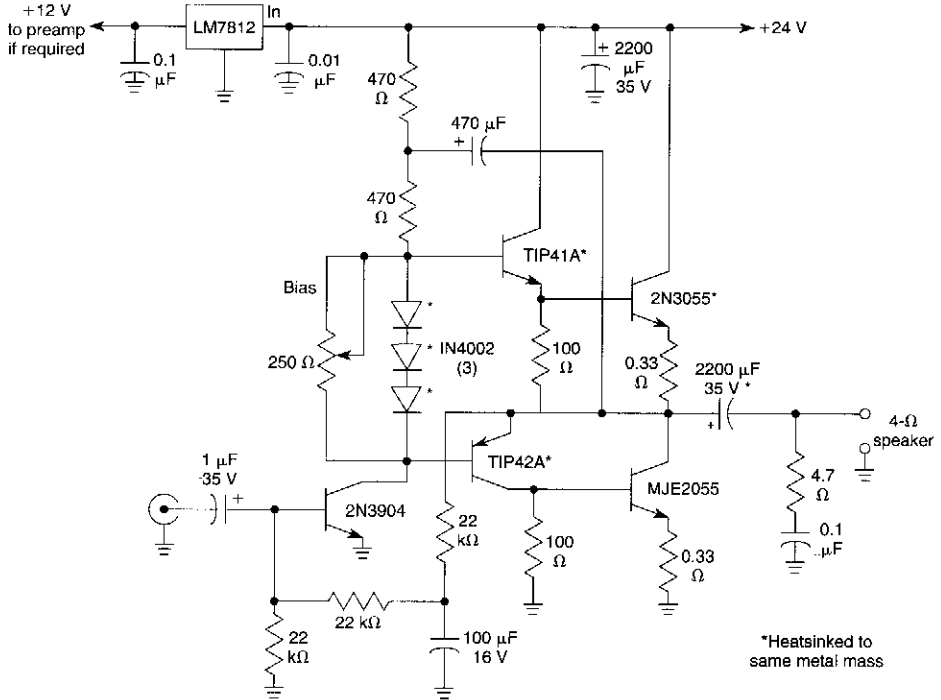

WILLIAM SHEETS

Fig. 11-3

This circuit is a general-purpose 10-W audio amplifier for moderate-power PA or modulator use in an AM transmitter. With higher voltages and a change in bias resistors, up to 30 W can be obtained.

POWER BRIDGE AMPLIFIER WITH SINGLE-ENDED OUTPUT

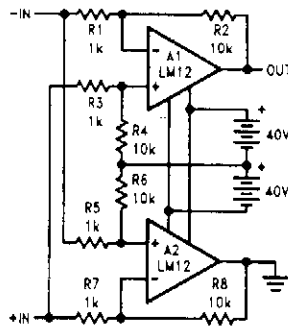

Bridge amplifier with a single-ended output uses floating supply. Either input can be grounded.

NATIONAL SEMICONDUCTOR

Fig. 11-4

LINE-OPERATED AUDIO AMPLIFIER

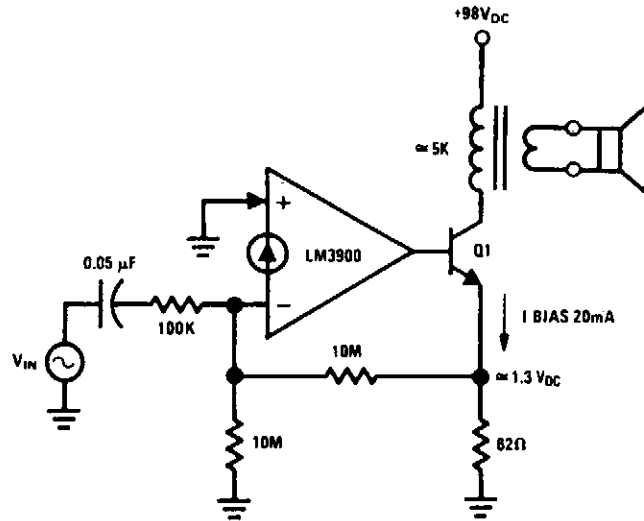

NATIONAL SEMICONDUCTOR

Fig. 11-5

An audio amplifier which operates off a $+98\text{-V}_{DC}$ power supply (the rectified line voltage) is often used in consumer products. The external high-voltage transistor, Q1, is biased and controlled by the LM3900. The magnitude of the dc biasing voltage, which appears across the emitter resistor of Q1 is controlled by the resistor. The resistor is placed from the (-) input to ground.

BASIC COMPLEMENTARY CLASS-AB POWER AMPLIFIER

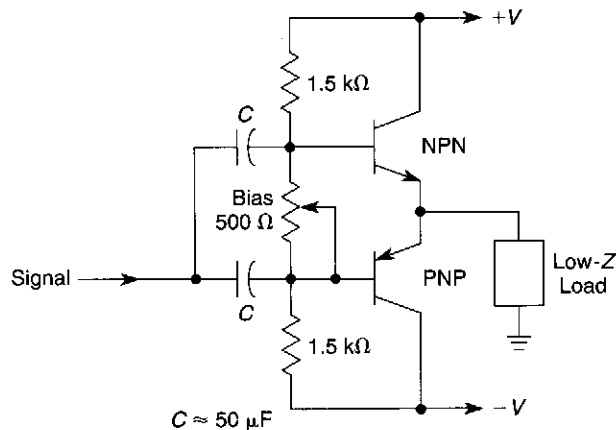

WILLIAM SHEETS

Fig. 11-6

SIMPLE VACUUM TUBE AMPLIFIER

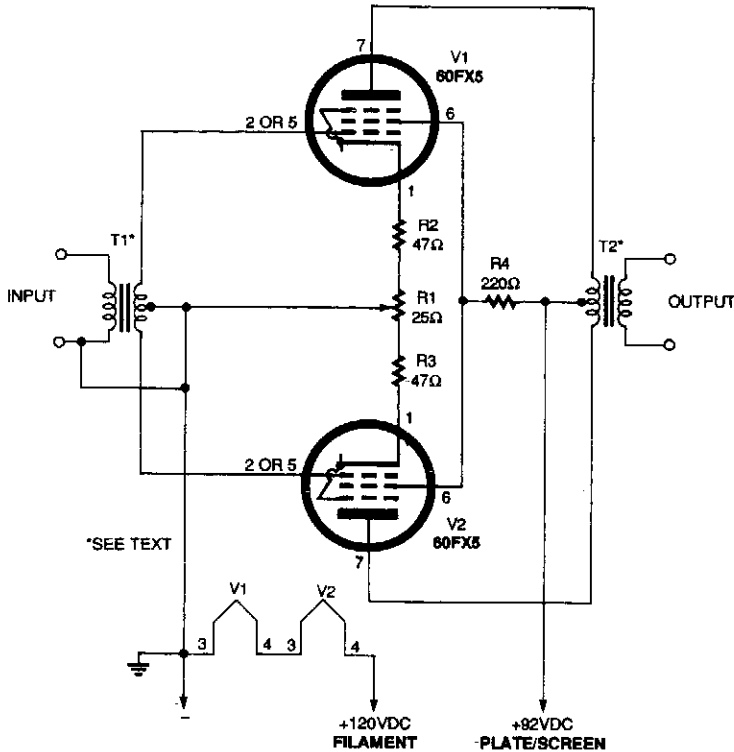

POPULAR ELECTRONICS

Fig. 11-7

Using a pair of 60 FX5 tubes, direct operation from 120 Vac is possible. However, the use of a power supply with an isolation transformer is recommended. R1 is adjusted for equal voltages at pin 1 of V1 and V2. The power output is about 2 to 3 watts.

POWER SUPPLY FOR VACUUM TUBE AMPLIFIER

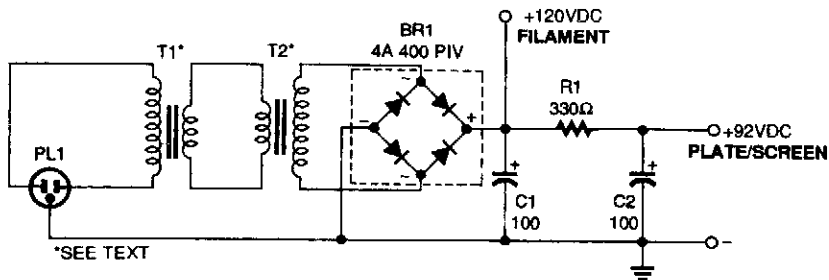

POPULAR ELECTRONICS

Fig. 11-8

The power supply for the amplifier uses two low-voltage transformers connected back-to-back. The full-wave bridge rectifier, BR1 provides dc for the filaments, plates, and screens.

16-W BRIDGE AMPLIFIER

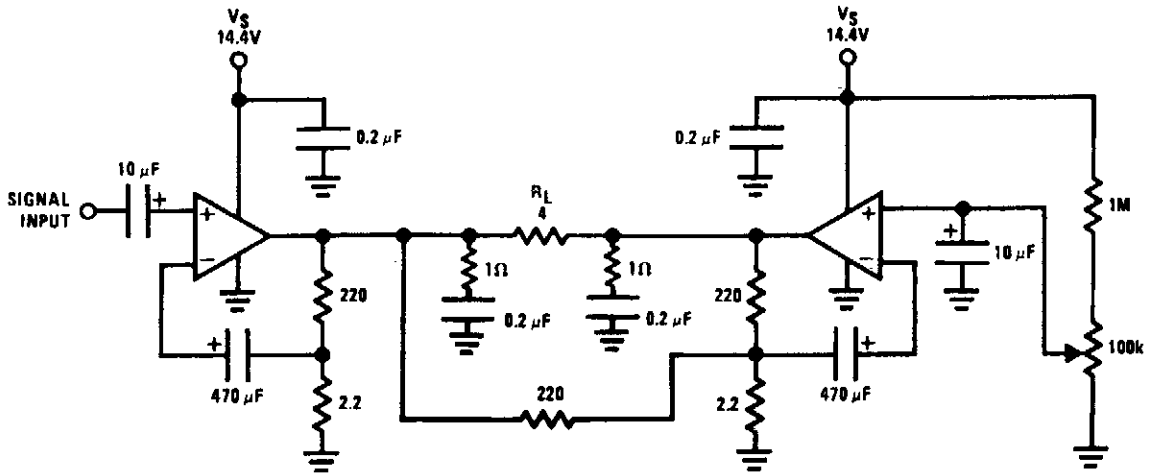

NATIONAL SEMICONDUCTOR

Fig. 11-9

This circuit delivers 16 W RMS audio into a 4-Ω load (R_L). The ICs are LM383s.

RFI-PROOF AUDIO POWER AMPLIFIER

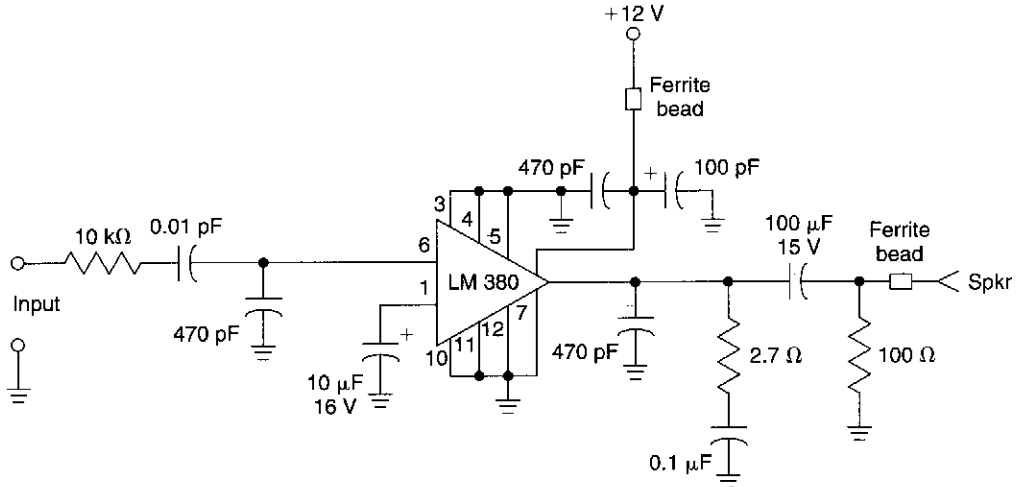

WILLIAM SHEETS

Fig. 11-10

This 1-watt audio amplifier was used in an FM repeater and proved to be immune to strong RF signal pickup. It functioned well in very strong RF fields.

BASIC QUASI-COMPLEMENTARY POWER AMPLIFIER WITH SPLIT POWER SUPPLIES

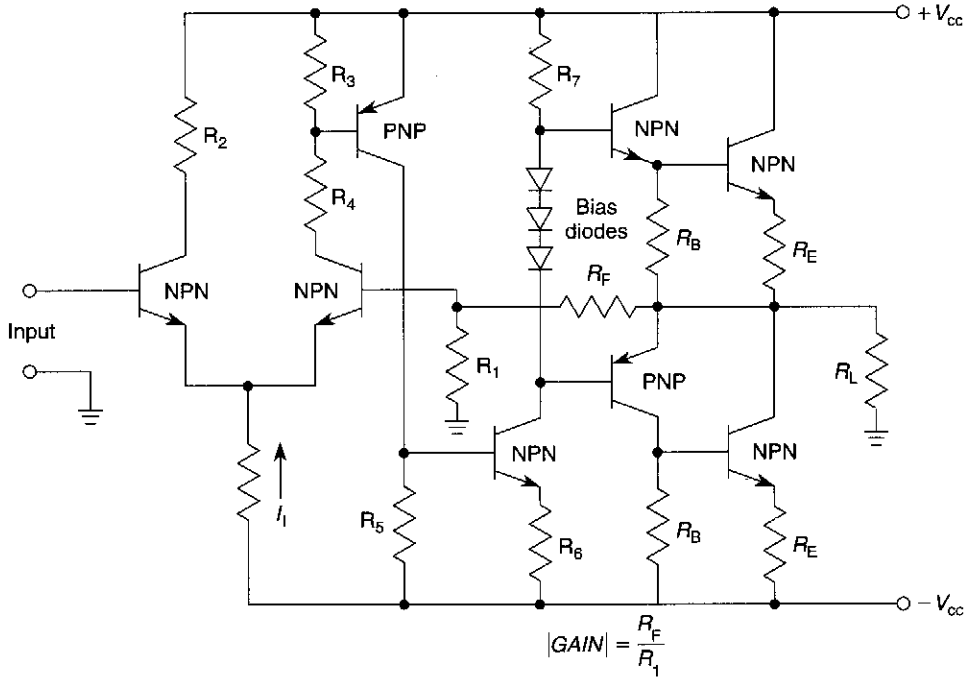

WILLIAM SHEETS

Fig. 11-11

This is the basic circuit used in many audio power output stages where split supplies are used. This amplifier is inherently dc coupled and has high open loop gain and good dc stability if the feedback network is properly designed.

RIAA PHONO AMPLIFIER

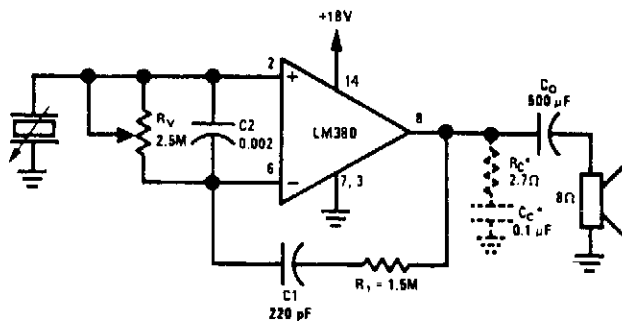

NATIONAL SEMICONDUCTOR

Fig. 11-12

$$\text{Mid-band gain} = \frac{R_1 + 150 \text{ k}\Omega}{150 \text{ k}\Omega}$$

BASIC QUASI-COMPLEMENTARY POWER AMPLIFIER CIRCUIT

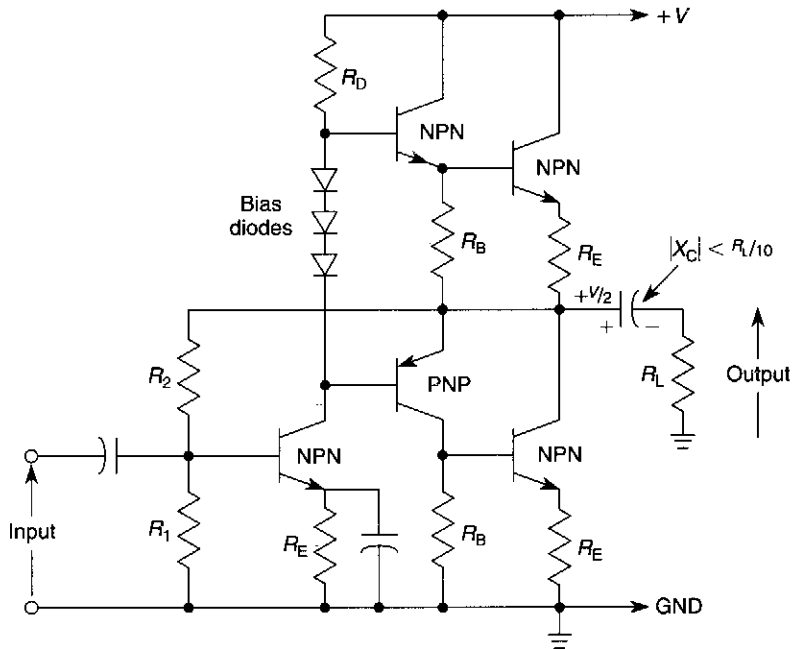

WILLIAM SHEETS

Fig. 11-13

PHONO AMP

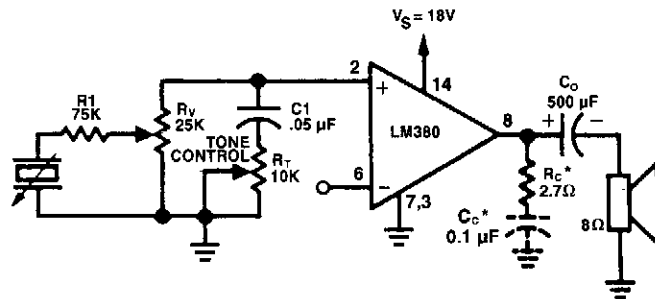

NATIONAL SEMICONDUCTOR

Fig. 11-14

The figure shows the LM380 with a voltage-divider volume control and high-frequency roll-off tone control.

80-WATT IC AUDIO AMPLIFIER

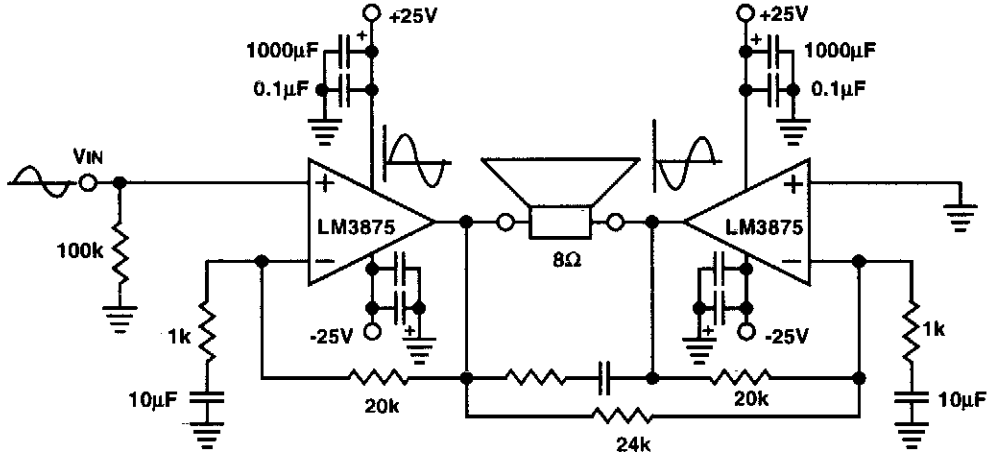

NATIONAL SEMICONDUCTOR

Fig. 11-15

This audio power amp will deliver 80 W of audio into an 8-Ω load. The LM3875 IC devices should be suitably heatsinked. Note that the amplifier is a bridged circuit, with both speaker leads “hot.”

BASIC COMPLEMENTARY POWER AMPLIFIER CIRCUIT

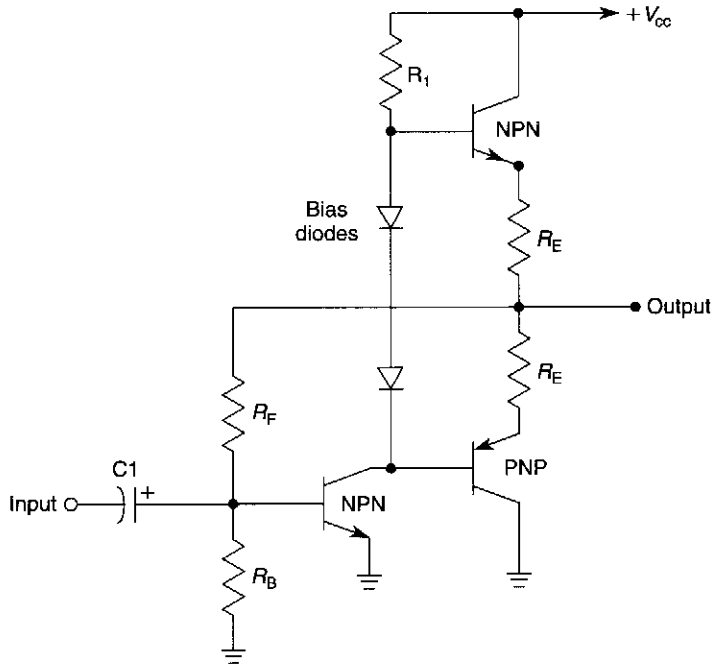

WILLIAM SHEETS

Fig. 11-16

GENERAL-PURPOSE AF AMPLIFIER

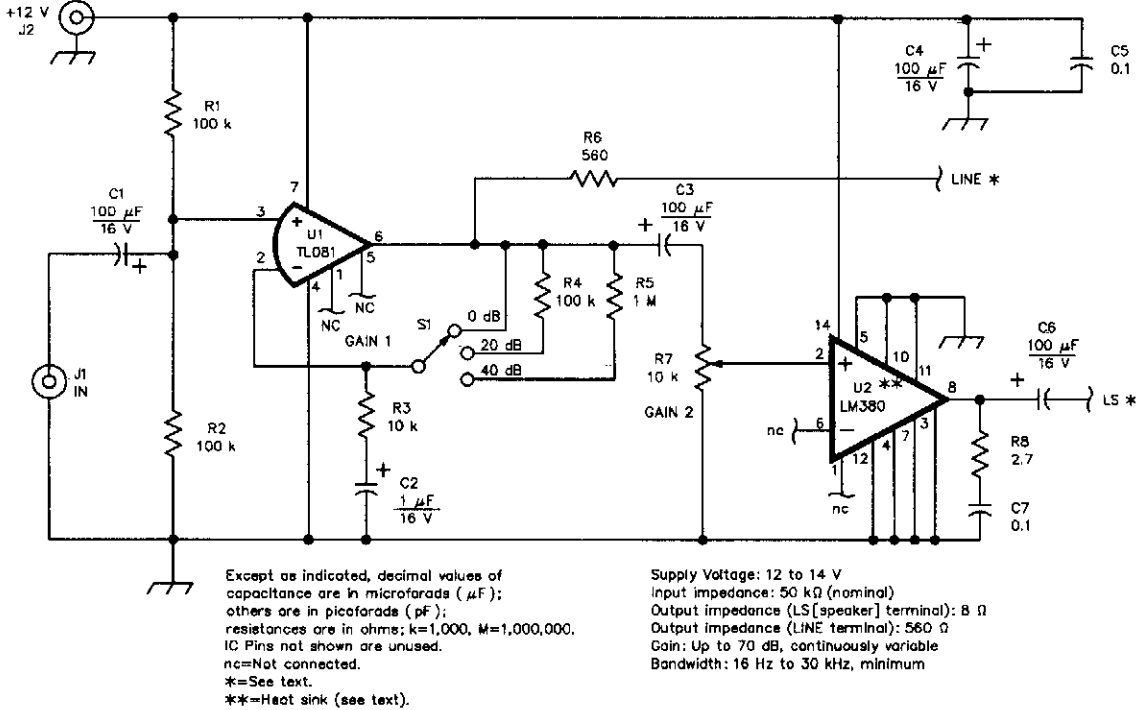
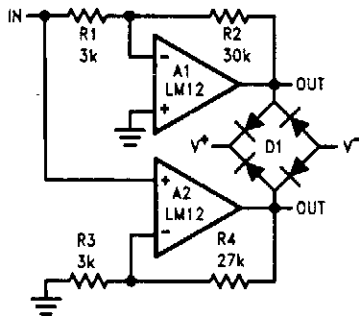

Fig. 11-17

QST

Schematic of the general-purpose AF amplifier. All resistors are $\frac{1}{4}$ -W, 5%-tolerance carbon-composition or metal-film units. Equivalent parts can be substituted. General-purpose IC replacements are shown in parentheses.

BRIDGE CONNECTION OF TWO POWER OP AMPS



These bridge connections provide differential outputs that approach twice the total supply voltage. Diode bridge clamps output to the supplies.

NATIONAL SEMICONDUCTOR

Fig. 11-18

90-V 10-A HIGH-POWER AMPLIFIER

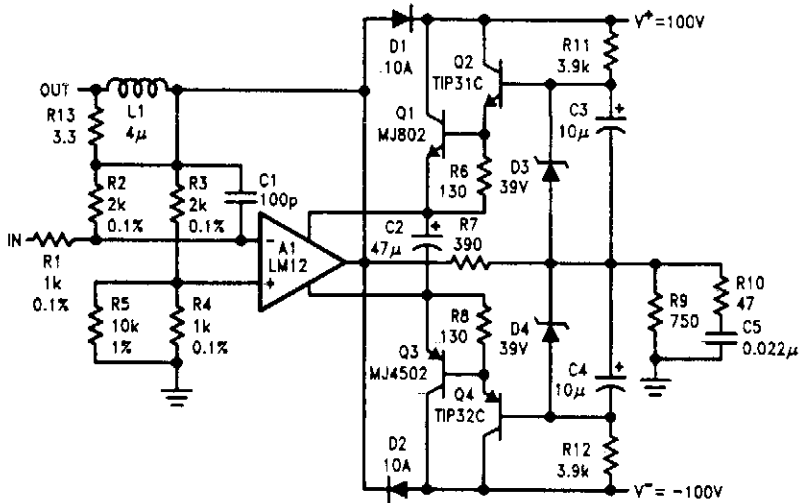

NATIONAL SEMICONDUCTOR

Fig. 11-19

This amplifier can drive ± 90 V at 10 A, more than twice the output swing of the LM12. The IC provides current and power limiting for the discrete transistors.

MINI-MEGAPHONE

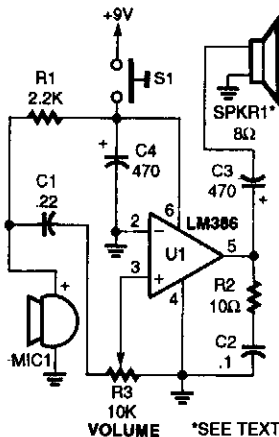

The Mini-Megaphone is comprised of an electret microphone (MIC1), and LM386 low-voltage audio-power amplifier (U1), a horn speaker (SPKR1), and a few other components.

POPULAR ELECTRONICS

Fig. 11-20

12

Automotive Circuits

The sources of the following circuits are contained in the Sources section, which begins on page 707. The figure number in the box of each circuit correlates to the entry in the Sources section.

Electronic Auto Stethoscope
Automotive Electrical Monitor
Car Alternator Monitor (Idiot Light)
Cigarette Lighter 9-V Adapter
Motorcycle Turn-Signal System
Tachometer Signal-Conditioning Circuit
Smart Turn Signal for Autos and Motorcycles
Turn-Signal Alarm
High-Power Audio Amp for Automotive Installation
High-Power 12-V IC Auto Amplifier
Capacitor Discharge Ignition System
Car Audio Power Supply
Motorcycle Headlight Monitor
Headlight-Off Indicator
Auto Battery Isolator Circuit
Automotive HI-Z Test Light

ELECTRONIC AUTO STETHOSCOPE

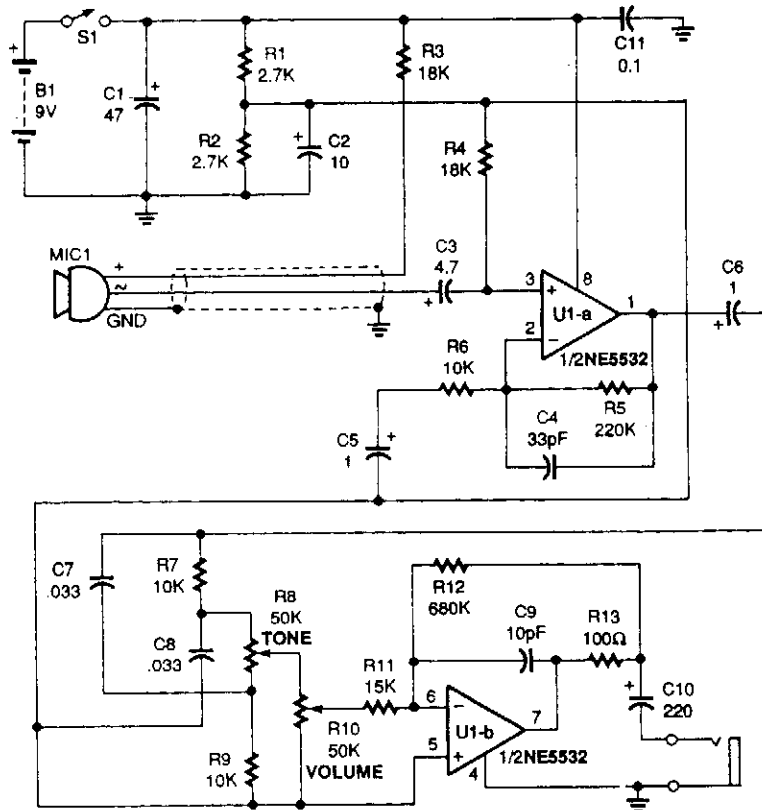

POPULAR ELECTRONICS

Fig. 12-1

The heart of the Stethoscope is the NE5532 audio op amp, U1. That component directly drives low impedances and allows the use of headphones without adding another amplifier.

AUTOMOTIVE ELECTRICAL MONITOR

TABLE 1—AUTOMOTIVE ELECTRICAL FAULTS

Condition	Normal Voltage	Possible Fault
Vehicle at rest	12.6 volts	<12.4 volts: bad cell or severely undercharged battery
Cranking	>9 volts	<9 volts: Weak battery
Idling	>12.8 volts	<12.8 volts: Not charging; bad alternator or wiring
Running minimum load	>13.4 volts	<13.4 volts: defective alternator or voltage regulator
Running minimum load	<15.2 volts	>15.2 volts: Overcharging; defective regulator
Running maximum load	>13.4 volts	<13.4 volts: alternator defective or belt slipping

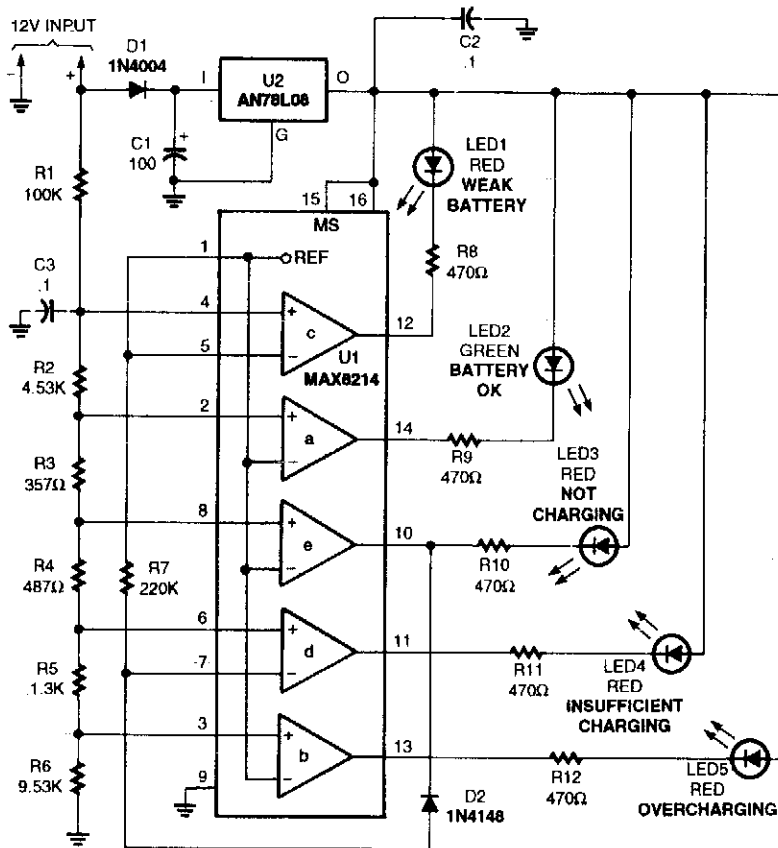

The automotive electrical diagnostic system is built around a Maxim MAX8214ACPE five-stage voltage comparator, which contains a built-in 1.25-volt precision reference, and on-board logic that allows the outputs of two of the comparators to be inverted.

CAR ALTERNATOR MONITOR (IDIOT LIGHT)

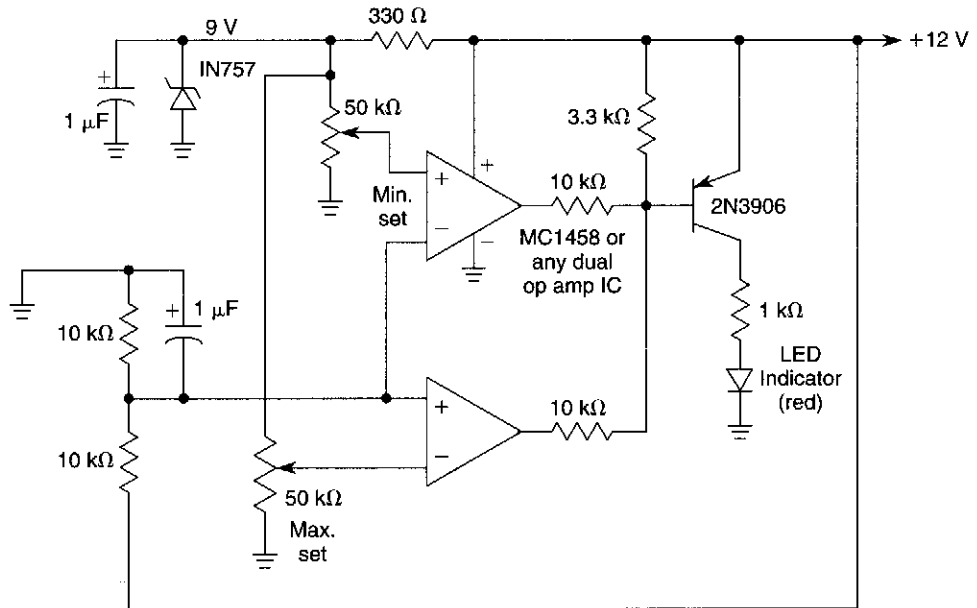

WILLIAM SHEETS

Fig. 12-3

A window comparator is used to detect a too-low or a too-high system voltage. The minimum and maximum settings are set with two 50-k Ω pots, as desired.

CIGARETTE LIGHTER 9-V ADAPTER

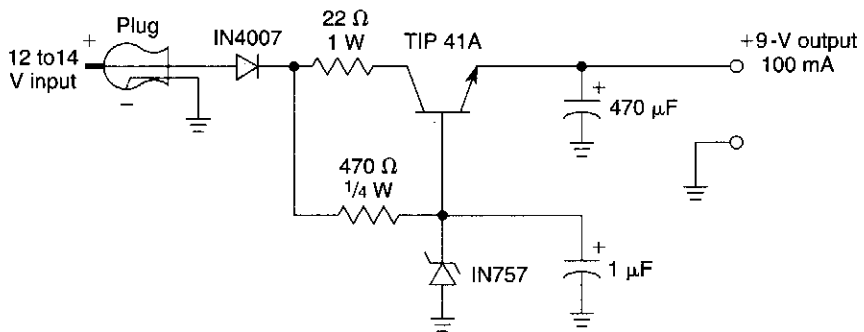

WILLIAM SHEETS

Fig. 12-4

A simple way to provide +9 V at 100 mA from a 12-V auto source. Applications include small radios, cassettes, etc.

MOTORCYCLE TURN-SIGNAL SYSTEM

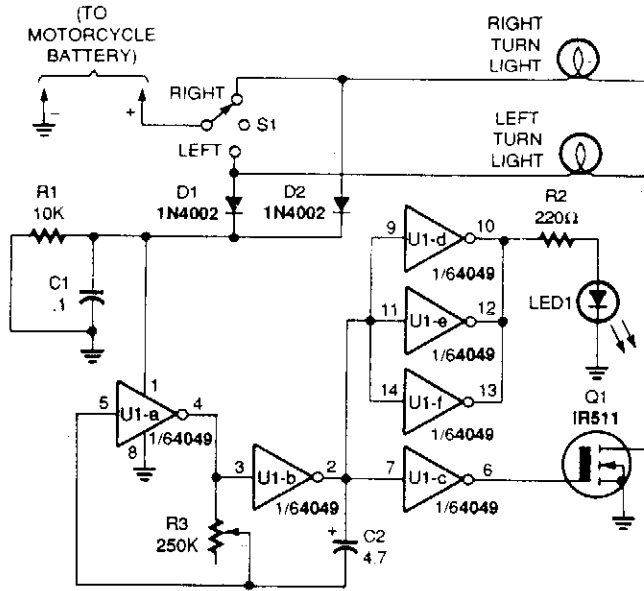

POPULAR ELECTRONICS

Fig. 12-5

Tired of making hand signals? Build this simple turn-signal system and keep your hands on the handlebars.

TACHOMETER SIGNAL-CONDITIONING CIRCUIT

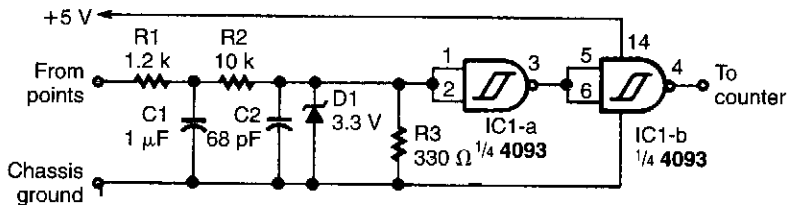

ELECTRONICS NOW

Fig. 12-6

This circuit, for use with auto tachometers, cleans up the ragged distribution waveform before it is sent to pulse counter circuits.

SMART TURN SIGNAL FOR AUTOS AND MOTORCYCLES

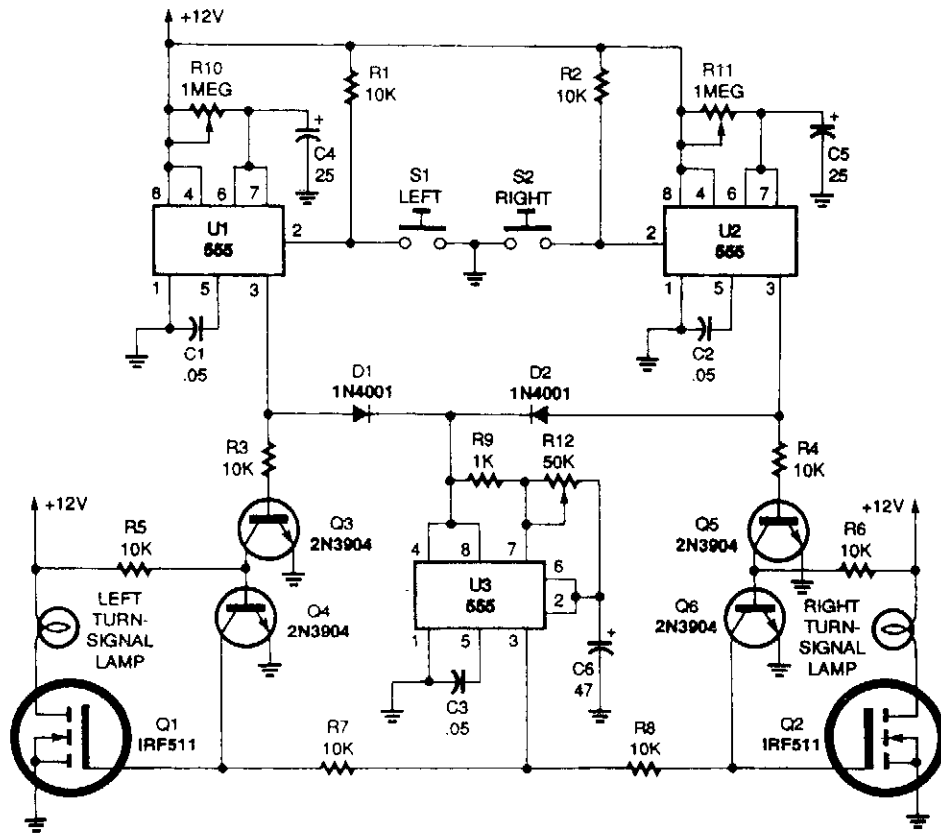

POPULAR ELECTRONICS

Fig. 12-7

Momentarily pressing S1 starts the left on-time timer and produces a positive output at pin 3 of U1. Power for the on/off signal timer, U3, is supplied through D1.

Also, a positive bias is supplied from U1's output to the base of Q3, turning it on and turning Q4 off. Unclamped Q1 turns the left turn-signal lamp on and off at that same low-frequency rate. Because U2 is not activated, its output at pin 3 is low, keeping Q5 off. With Q5 turned off, Q6 is on, clamping the gate of Q2 to ground and keeping it from responding and supplying an output for the right turn-signal lamp. The left turn signal continues to operate until the U1 timer circuit times out; the right turn signal operates in a similar manner, with U2 setting its operating time.

Potentiometer R10 sets the running time for the left turn signal and R11 sets that for the right turn signal.

TURN SIGNAL ALARM

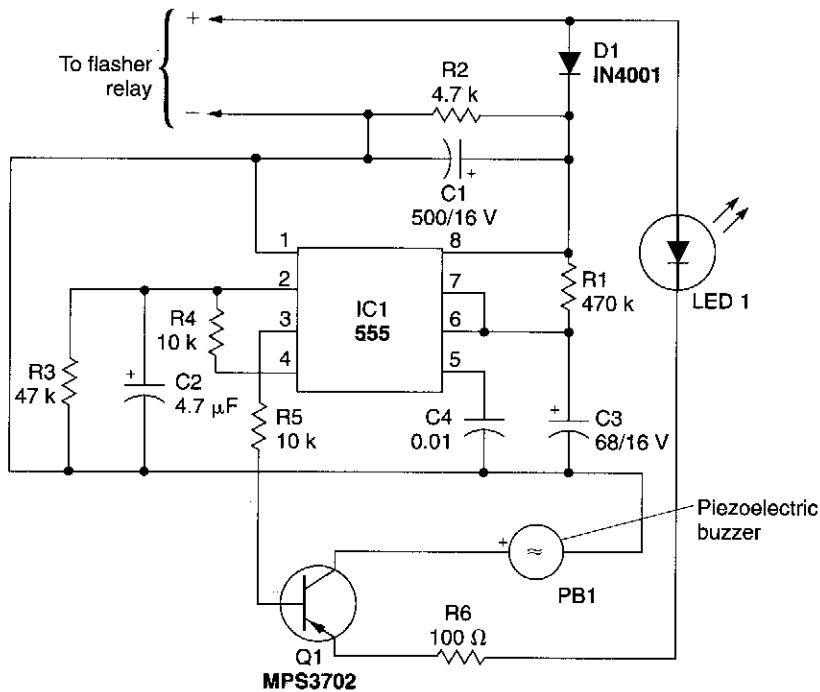

RADIO-ELECTRONICS

Fig. 12-8

This circuit can be used to tell the driver of a vehicle when his or her turn signal has been left on for too long. The circuit consists of IC1, a 555 timer; transistor Q1, and MPS3702 PNP preamp/driver; PB1, a piezoelectric buzzer; along with an assortment of resistors, capacitors, and diodes. The 555 is connected in the monostable mode, requiring only a momentary negative pulse at pin 2 to trigger the timing cycle.

Power for the circuit is picked off the flasher relay and applied to IC1, pin 8, provided by an initially discharged capacitor, C2. After the initial triggering, the voltage across C2 rises as it becomes charged through R4, a 10-k Ω resistor. This prevents subsequent interference with the delay function caused by false triggering.

Capacitor C3 and resistor R1 determine the delay. With the component values shown, a delay of about one minute will be provided before the intermittent tweet sound generated by the circuit begins. If higher values are used for C2 and R1, a longer delay time will result. The light-emitting diode, LED1, provides a voltage drop to assure complete transistor blocking during the off periods of the flasher. Alternatively, two diodes in series can be used.

HIGH-POWER AUDIO AMP FOR AUTOMOTIVE INSTALLATION

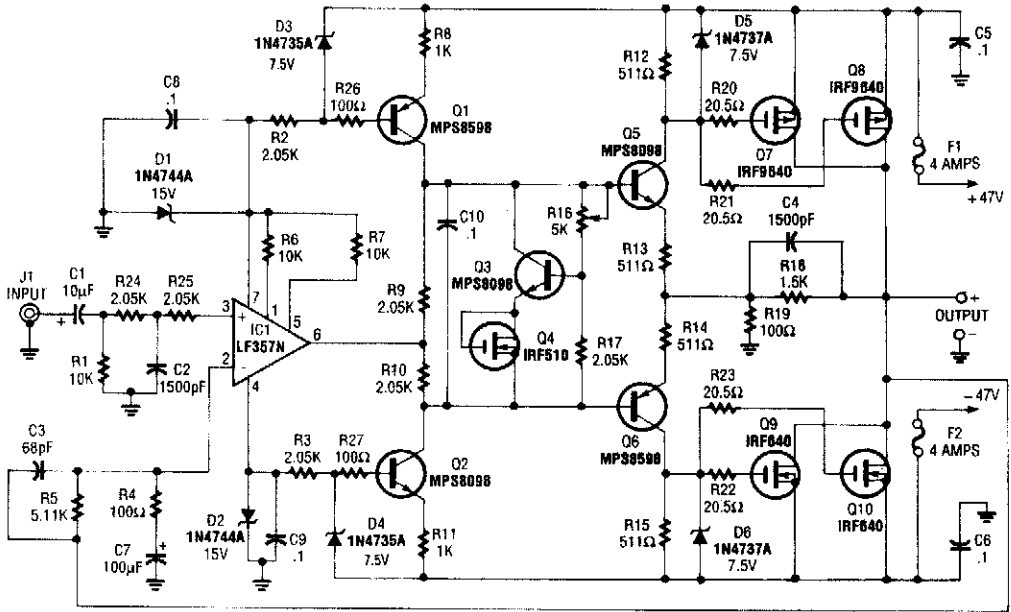

RADIO-ELECTRONICS

Fig. 12-9

Two of these audio amplifiers can be used to make a stereo amplifier 200 W per channel. IRF640 and IRF9640 power MOSFETs are used to drive the output load, which might be 4 or 8 Ω . Response is 12 Hz to 45 kHz (-3 dB), THD $<0.1\%$. Power is supplied by a switching-type power supply, which is external to the amplifier (± 47 V). About 600 W total power (peak) is needed.

HIGH-POWER 12-V IC AUTO AMPLIFIER

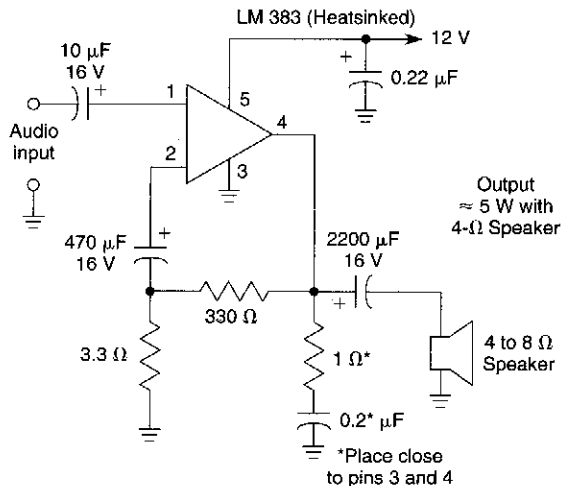

WILLIAM SHEETS

Fig. 12-10

CAPACITOR DISCHARGE IGNITION SYSTEM

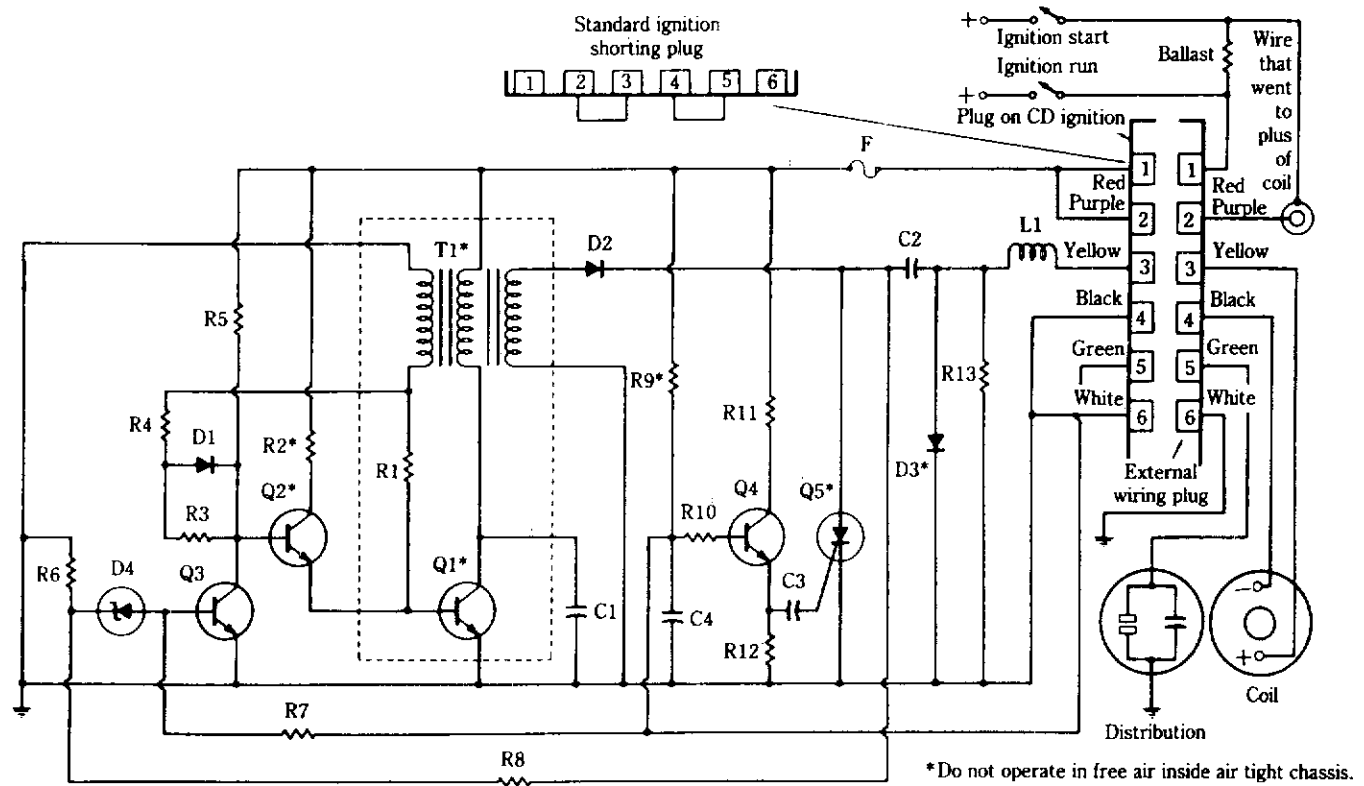

MCGRAW-HILL

Fig. 12-11

This ignition system charges a capacitor (C2) to 350 V and discharges it through the ignition coil.

CAPACITOR DISCHARGE IGNITION SYSTEM (Cont.)

A Parts list

- Q1—2N3055
- Q2—2N3053
- Q3—2N3241
- Q4—2N3241
- Q5—RCA 40657
- D1—1N3193
- D2—1N3195
- D3—1N1763A
- D4—12 V, 1/4 W
- C1—0.25 μ F, 200 V
- C2—1 μ F, 400 V
- C3—1 μ F, 25 V
- C4—0.25 μ F, 25 V
- F—5A
- L1—10 μ H, 100 Turns of No. 28 Wire Wound on a 2-W Resistor (100 Ohms or More)
- R1—1000 ohms, 1/2 W
- R2—35 ohms, 5 W
- R3—22,000 ohms, 1/2 W
- R4—1000 ohms, 1/2 W
- R5—18,000 ohms, 1/2 W
- R6—15,000 ohms, 1/2 W
- R7—8200 ohms, 1/2 W
- R8—0.39 megohm, 1/2 W
- R9—220 ohms, 1 W
- R10—1000 ohms, 1/2 W
- R11—68 ohms, 1/2 W
- R12—4700 ohms, 1/2 W
- R13—27,000 ohms, 1/2 W

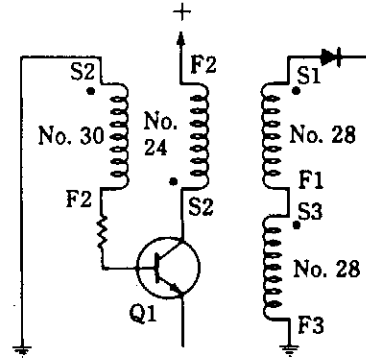

Details of inverter transformer

CAR AUDIO POWER SUPPLY

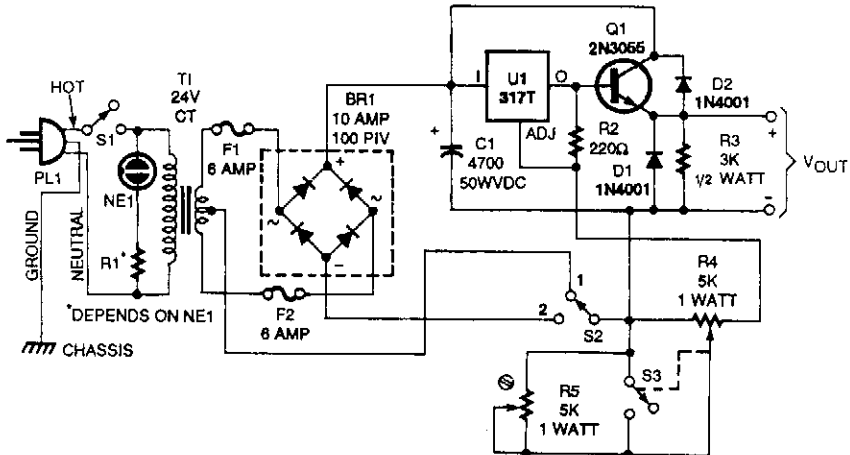

POPULAR ELECTRONICS

Fig. 12-12

This supply has a variable output voltage feature and a dual voltage switch, S2. Q1 should be adequately heatsinked.

MOTORCYCLE HEADLIGHT MONITOR

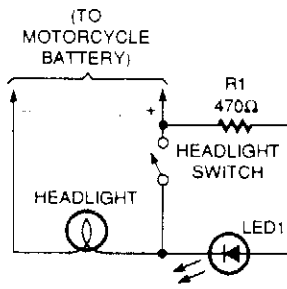

POPULAR ELECTRONICS

Fig. 12-13

The headlight on most newer bikes is keyed on with the ignition switch to guarantee that you are never underway without your headlight being on. However, many older bikes have a factory headlight switch, and a growing number of the newer bikes are owner-modified in the same way.

A simple headlight monitor circuit consists of just an LED and a current-limiting resistor wired across the headlight switch, as shown. When the ignition is on and the headlight switch is off, the LED will glow.

HEADLIGHT-OFF INDICATOR

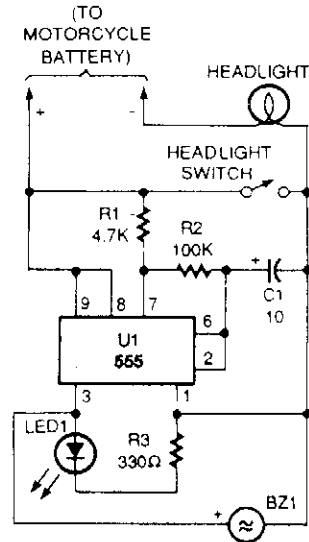

POPULAR ELECTRONICS

Fig. 12-14

Increasing the value of R_2 or C_1 will lower the oscillator's frequency and decreasing one of those values will increase the frequency. The IC's output at pin 3 drives the LED through R_3 and sends power to the piezo sounder. Use a bright LED so that you will be able to see it in the daytime.

AUTO BATTERY ISOLATOR CIRCUIT

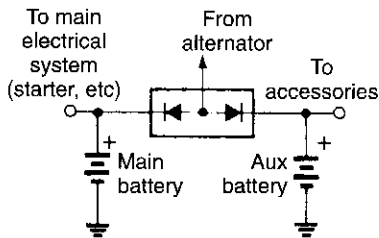

ELECTRONICS NOW

Fig. 12-15

The diodes ensure that current can flow in both batteries from the alternator, but the main battery can't feed the accessory system, nor vice versa.

AUTOMOTIVE HI-Z TEST LIGHT

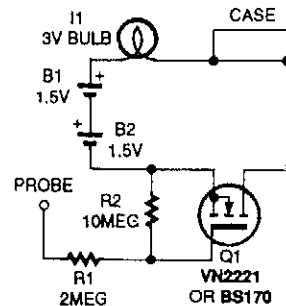

POPULAR ELECTRONICS

Fig. 12-16

This test light has a high-input impedance and draws only 1 mA at 12 V. Q_1 switches dc to a battery and lamp circuit.

13

Battery Charger Circuits

The sources of the following circuits are contained in the Sources section, which begins on page 707. The figure number in the box of each circuit correlates to the entry in the Sources section.

- Smart Battery Charger
- Rechargeable LED Flashlight
- Battery Charger Controller
- Single-Cell Lithium Battery Charger
- Battery-Charging Current Limiter
- Three-Cell Lithium Charger
- NiCad Battery Charger
- Backup Battery Monitor/Charger/Alarm
- NiCad Charger/Zapper
- 2- to 5-Cell Lithium Battery Charger
- Lead-Acid Trickle Charger
- NiCad Battery Charger

SMART BATTERY CHARGER

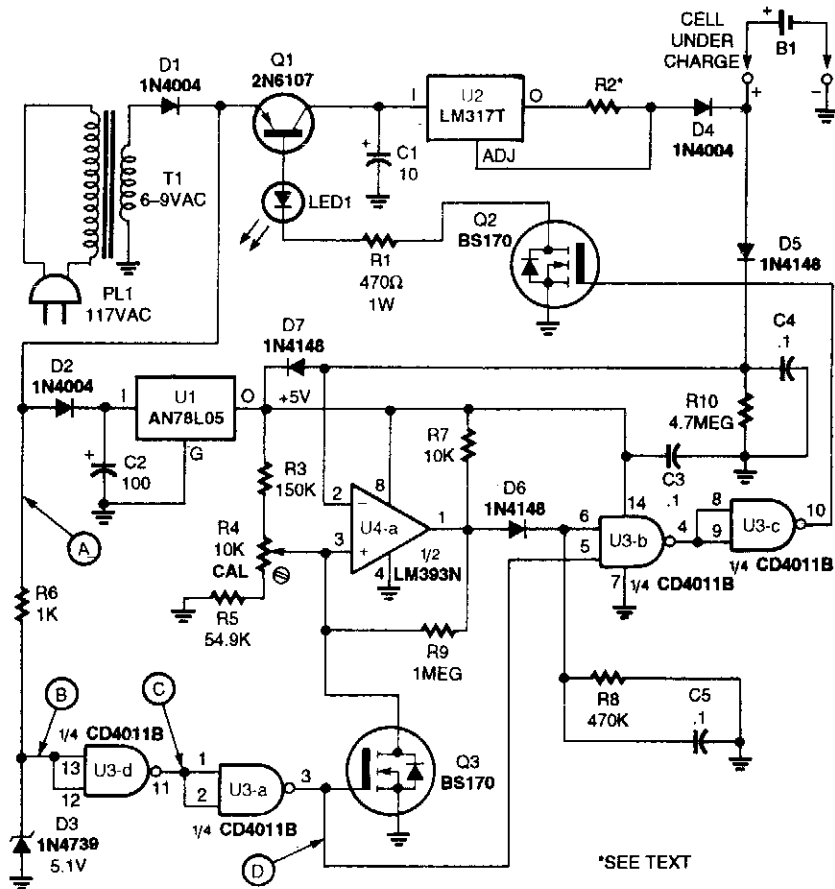

*SEE TEXT

ELECTRONICS NOW

Fig. 13-1

This charger will work with NiCad or the new rechargeable alkaline batteries. The Smartcharger is comprised mainly of four chips—an AN78L05 5-V, 100-mA regulator (U1), an LM317T 1-A adjustable-voltage regulator (U2), a CD4011BE quad 2-input NAND gate (U3), and an LM393N dual-voltage comparator (U4). The value and rating of R2 is selected as described in the text. R2 is selected for a 1.2-V drop across it at the charging current (3 Ω for 400 mA, 6 Ω for 200 mA).

RECHARGEABLE LED FLASHLIGHT

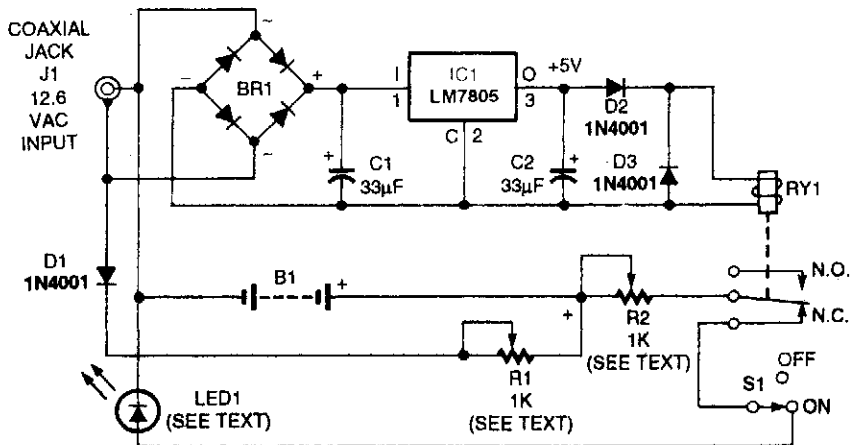

ELECTRONICS NOW

Fig. 13-2

This flashlight is useful for applications where night vision and/or darkness adaptation must be maintained. It uses an HLMP8150 T4 LED with a wavelength of 637 nm. This schematic is for the flashlight module. When the battery pack consisting of the four NiCad cells is fully charged (and there is no voltage at J1), 4.8 Vdc flows through trimmer potentiometer R2, the normally closed contact of relay RY1, and push-on/push-off power switch A1. Trimmer R2 limits the current flowing through LED1. Switch S1 can turn LED1 on and off when the battery is not being charged.

BATTERY CHARGER CONTROLLER

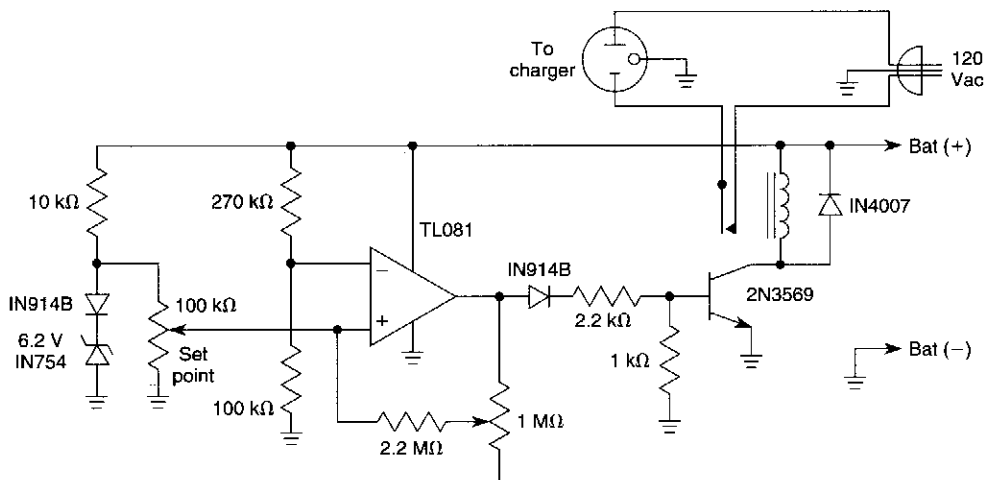

WILLIAM SHEETS

Fig. 13-3

When the battery voltage is low, the TL081 comparator produces a high output, turning on the 2N3569 relay driver. As the battery voltage approaches the set point, the relay driver is cut off, opening the 120-Vac supply.

SINGLE-CELL LITHIUM BATTERY CHARGER

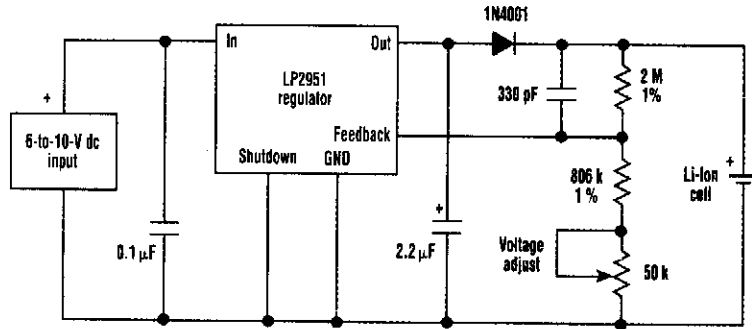

ELECTRONIC DESIGN

Fig. 13-4

An LP2951 regulator was chosen for this single lithium cell-charging circuit for its built-in current-limiting capability. In addition, the regulator's output voltage is extremely stable, which is a prerequisite for lithium battery charging. This figure details an example circuit designed to recharge a single cell. The required output set voltage was specified as 4.200 V (± 0.025 V) with a maximum charging current of about 150 mA.

An LP2951 regulator was selected for two reasons. One is that its built-in current limiter holds the maximum current to 160 mA (typical). The other is because the output voltage can be very accurately set to 4.200 V, thanks to the regulator's stable internal bandgap reference.

The 1.23-V reference appears between the feedback pin and ground, which causes a precise current to flow in the output resistive-divider string. The amount of current flowing in these resistors determines (sets) the charger output voltage that appears across the battery terminals. Large-value resistors keep the battery drain below 2 μ A when the dc input is removed (a customer requirement). A trimming potentiometer sets the output to 4.200 V. It must be adjusted when the battery isn't connected to the charger output. A blocking diode is required at the LP2951's output to prevent current from flowing out of the battery and back into the output when the dc-input source is removed. Because the diode is in series with the output, the minimum input-output voltage differential required for this circuit to operate is about 1.5 V.

BATTERY-CHARGING CURRENT LIMITER

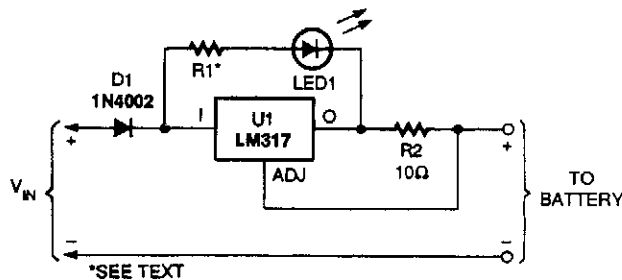

POPULAR ELECTRONICS

Fig. 13-5

This circuit uses an LM317 as a current regulator to limit charging current to a lead-acid battery. R2 should produce a 1.2-V drop at the desired limiting value of charging current.

THREE-CELL LITHIUM CHARGER

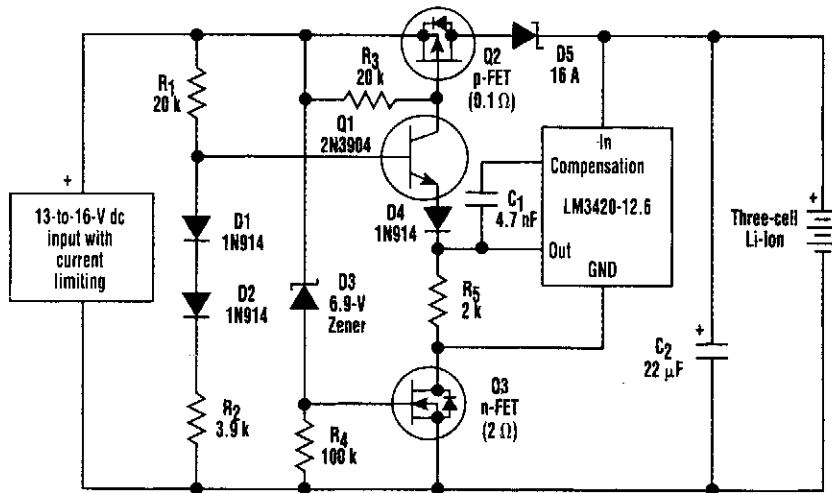

Fig. 13-6

ELECTRONIC DESIGN

This 3-A, three-cell charging circuit for lithium batteries includes a built-in on/off switch made up of Q3, R4, and D3. When a dc input is present, D3 turns on Q3, which allows current to flow through the LM3411 and Q1. If dc voltage is removed, Q3 turns off, cutting battery drain to zero.

NICAD BATTERY CHARGER

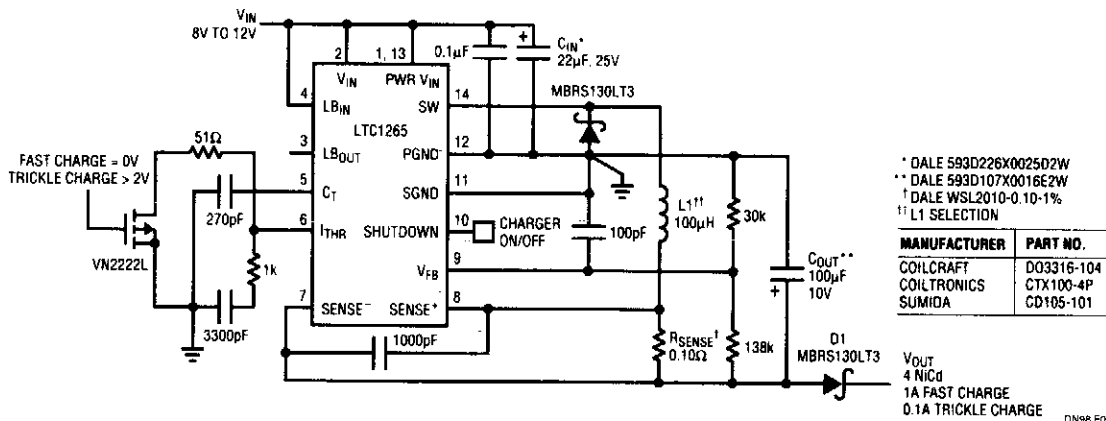
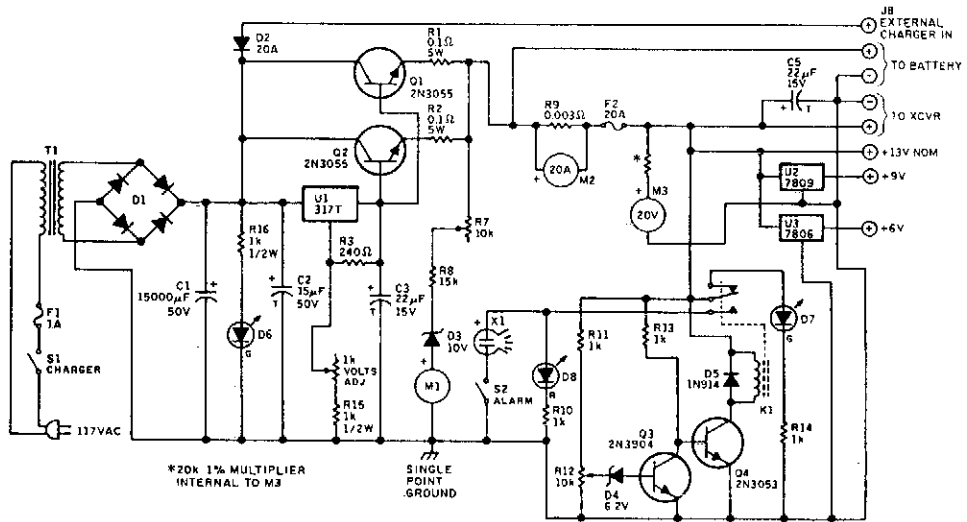

Fig. 13-7

LINEAR TECHNOLOGY

The LTC1265 is configured as a battery charger for a four-NiCad stack. It has the capability of performing a fast charge of 1 A, a trickle charge of 100 mA, or the charger can be shut off. In shut-off, diode D1 serves two purposes. First, it prevents the LTC1265 circuitry from drawing battery current and second, it eliminates “back powering” the LTC1265, which avoids a potential latch condition at power up.

BACKUP BATTERY MONITOR/CHARGER/ALARM



73 AMATEUR RADIO TODAY

Fig. 13-8

Battery Condition Meter Calibration

Lead-Acid Battery		Lead Calcium Battery	
Color	Voltage	Color	Voltage
Red	11.6 and below	Red	11.6 and below
Yellow	11.6 to 12.0	Yellow	11.6 to 12.0
Green	12.0 to 13.8	Green	12.0 to 13.5
Red	13.8 and higher	Red	13.5 and higher

Charging voltage is constant at the normal full-charge level, so the charging current drops as full charge is approached, and full charge is maintained with a trickle current. The charging voltage can be adjusted between approximately 10 and 15 Vdc to accommodate lead-acid (13.8 V) or lead-calcium (13.2 V, 13.5 V maximum) deep-cycle storage batteries.

A separate connection is provided so that an external charger can be used when greater than 3 A is needed to charge a partially discharged battery. Internal circuitry will maintain the charging voltage to the battery at the nominal full-charge voltage level, regardless of the voltage supplied by the external charger, which will be 2 V or more greater than that applied by the regulator to the storage battery. Warning: do not fast-charge deep-cycle storage batteries!

A pair of meters calibrated to indicate 20 Vdc and 20 Adc full-scale monitor voltage and current when battery power is used.

A separate, suppressed zero, expanded-scale meter calibrated over the range of about 10 to 15 Vdc allows immediate and constant indication of the state of charge of the station's backup battery. This meter scale is calibrated in bands of red, yellow, and green, as explained in the table. The narrow yellow segment is based on the assumption that solid-state transceivers might not operate properly below +12 Vdc. The internal power supply is used to calibrate this meter. A DMM should be used for greatest accuracy.

BACKUP BATTERY MONITOR/CHARGER/ALARM (Cont.)

An alarm circuit is included to indicate when the battery has been discharged by 60 percent to the 11.6-Vdc level. When battery voltage is above 11.6 V, the green LED will be illuminated; when voltage falls to 11.6 V, the green LED goes out and the red LED lights. A piezo audible alarm sounds at this low-voltage level unless silenced by the toggle switch controlling it.

A pair of fixed three-terminal regulators are included to provide +9 and +6 Vdc.

NICAD CHARGER/ZAPPER

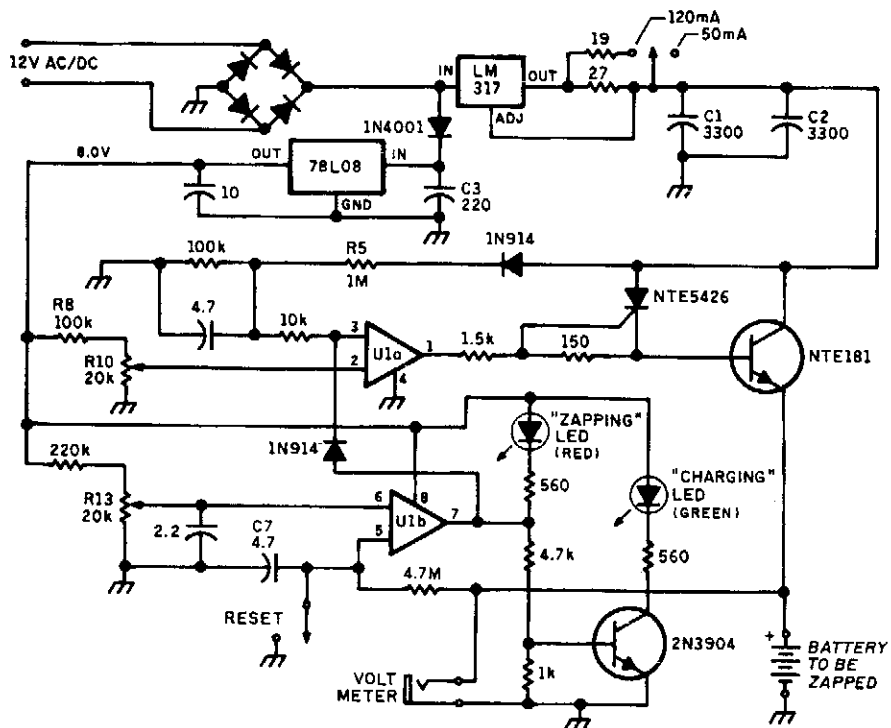

The NiCad charger/zapper has a built-in charger and zapper circuit to clear shorted NiCads. This circuit delivers a high-current pulse to trim out internal shorts.

2- TO 5-CELL LITHIUM BATTERY CHARGER

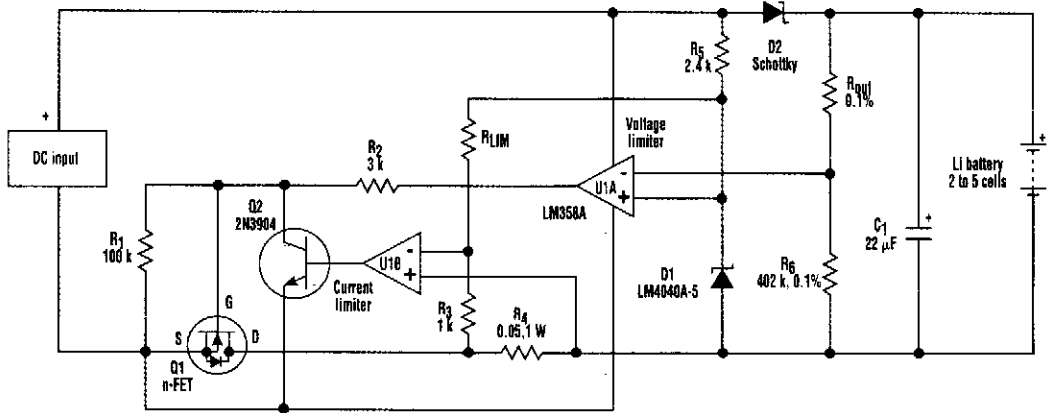

Fig. 13-10

ELECTRONIC DESIGN

A more generally applicable circuit-design concept for recharging lithium batteries could easily accommodate different cell types and various numbers of cells. That's because both the charger output-voltage set point and current limit, or maximum charging current, can be adjusted by simply changing a resistor.

LEAD-ACID TRICKLE CHARGER

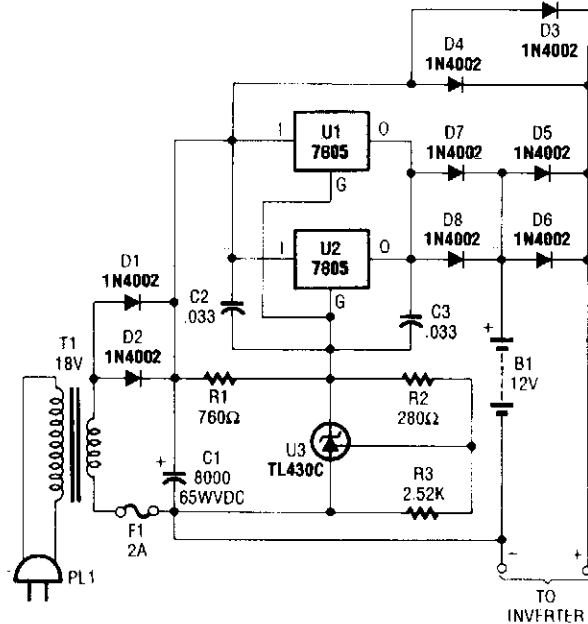

Fig. 13-11

POPULAR ELECTRONICS

This lead-acid battery trickle charger can be used as a stand-alone circuit (for alarm systems and such) or combined with the circuit in the figure to create an emergency lighting system.

NICAD BATTERY CHARGER

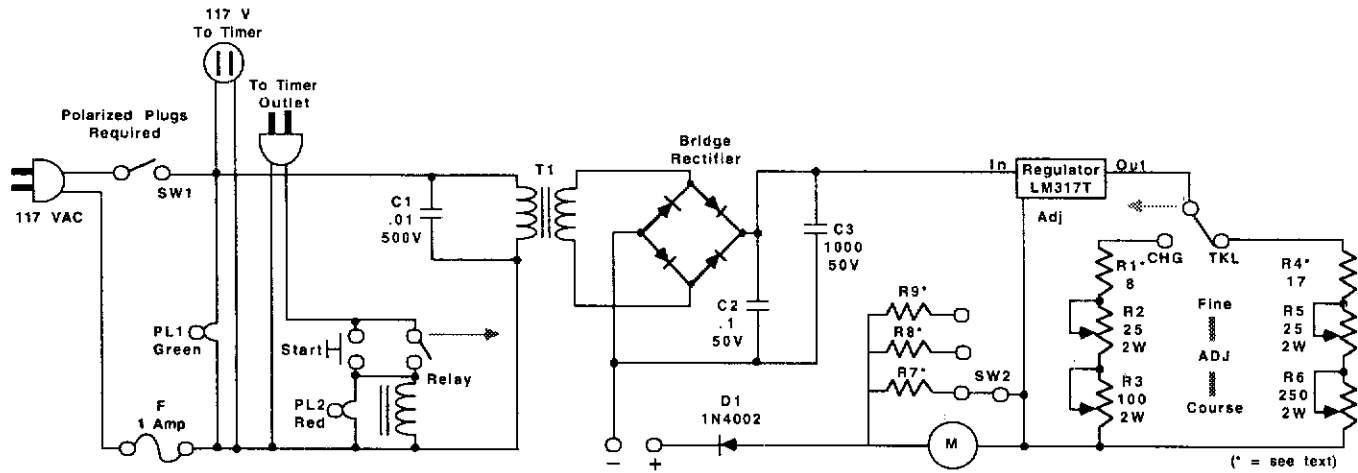

Fig. 13-12

This circuit has a current regulator and uses an external timer to control the charging rate.

14

Battery Monitor Circuits

The sources of the following circuits are contained in the Sources section, which begins on page 707. The figure number in the box of each circuit correlates to the entry in the Sources section.

- Battery Monitor
- Battery Butler
- Undervoltage Indicator for Single Cell
- Battery Charger Probe
- Low-Battery Circuit
- Battery Charge Indicator
- Battery Status Indicator
- Lithium Memory Backup Replacement
- Battery-Condition Indicator for 12-V Batteries

BATTERY MONITOR

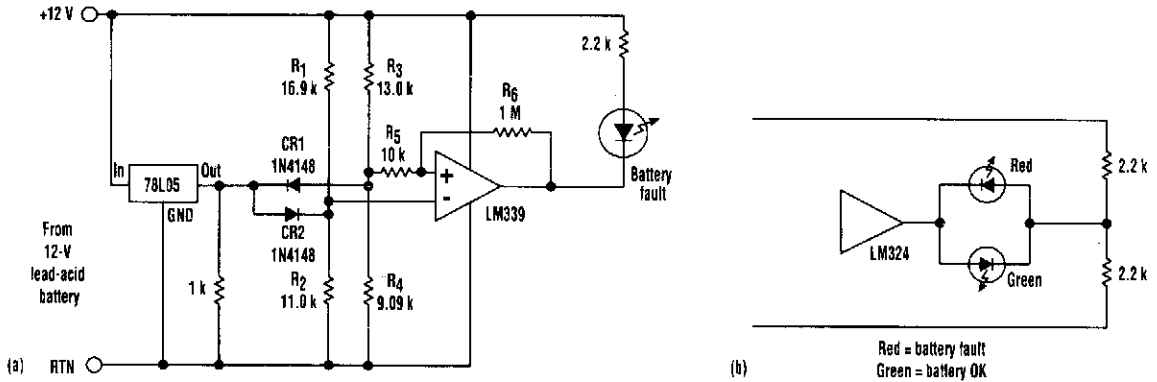

ELECTRONIC DESIGN

Fig. 14-1

One typical application for the detector involves monitoring a lead-acid battery. It indicates a fault when the battery voltage is outside an 11- to 14-V window. Because the circuit is powered by the battery, the input and reference were switched to keep the comparator inputs within its common-mode range.

The circuit's reference is 5.0 V. The resistor values in divider, R1/R2 were selected to produce 5.5 V at the inverting input when the battery voltage is 14.0 V. Divider R3/R4 is set to produce 4.5 V at the noninverting input when the battery voltage is equal to 11.0 V.

When the battery voltage is within the window, the noninverting input is more positive than the inverting input which is clamped at 4.5 V by CR2, the noninverting input continues below that, the comparator's output goes low, and the LED turns on. When the battery voltage rises above 14 V, the noninverting input is clamped at 5.5 V by CR1, the inverting input continues above that, the comparator output again goes low, and the LED turns on. Resistors R5 and R6 show that hysteresis might be added to this circuit in a conventional manner.

If an op amp, such as an LM324 is used as the comparator, two LEDs can be implemented. The green LED will turn on when the battery voltage is within the window, and the red LED turns on when the battery voltage is outside the window.

BATTERY BUTLER

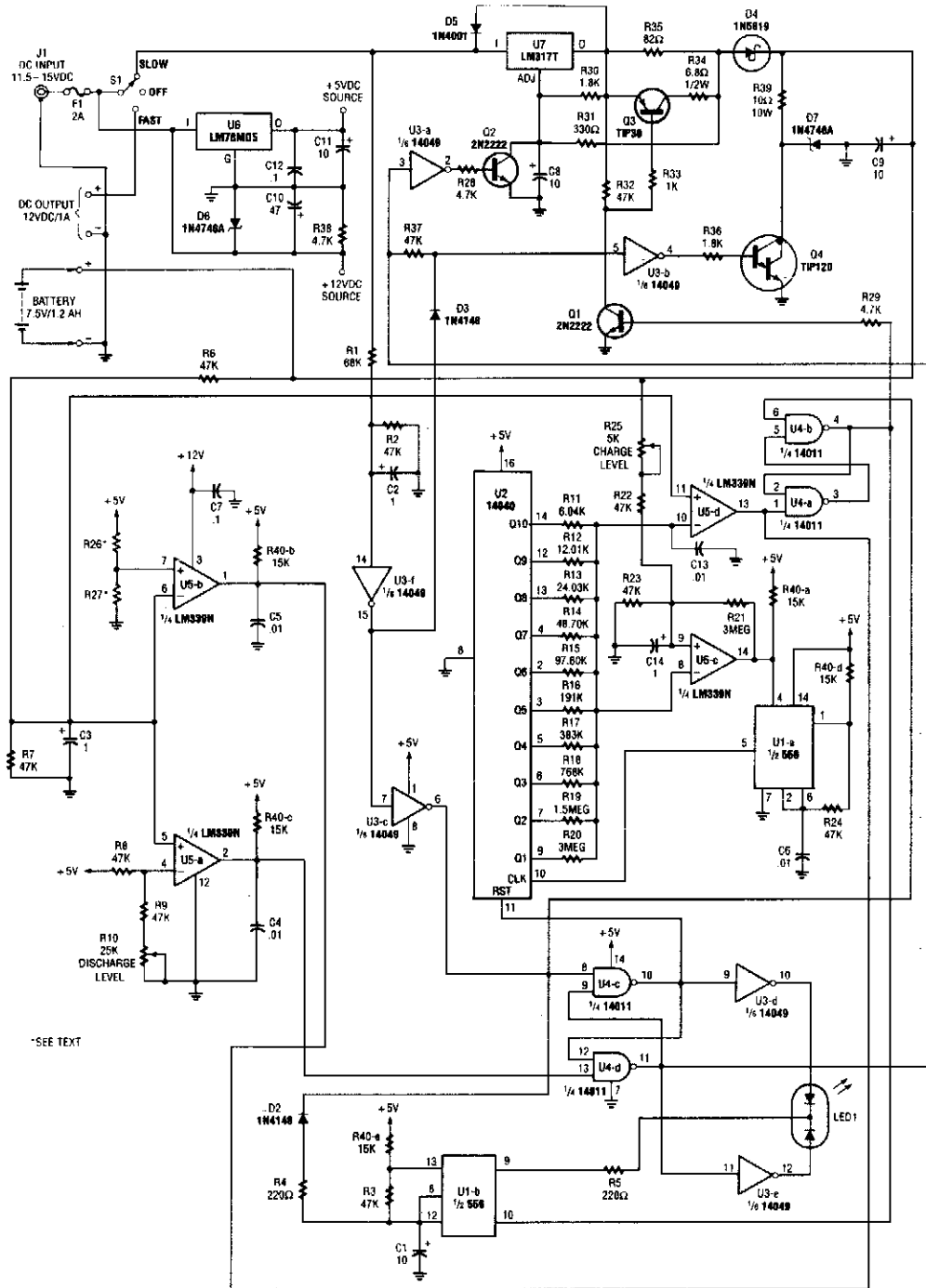

*SEE TEXT

BATTERY BUTLER (Cont.)

The battery butler solves the common problems associated with the maintenance and operation of NiCad batteries. The battery butler, by initially discharging a NiCad battery to a preset point, reduces the possibility of the "memory" effect occurring. Once discharged, a battery is then usually charged at 25% and reduce the internal cell pressure increase by 40% or more. Once the battery is fully charged, a trickle charge is provided to maintain the battery in a fully charged state. The battery butler circuit can be bypassed, and the existing fast-charger used, if needed.

UNDervOLTAGE INDICATOR FOR SINGLE CELL

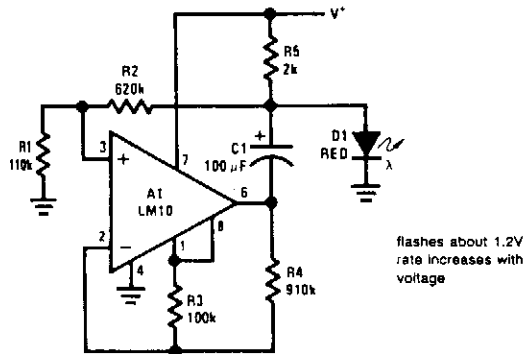

NATIONAL SEMICONDUCTOR

Fig. 14-3

When operating with a single cell, it is necessary to incorporate switching circuitry to develop sufficient voltage to drive the LED. A circuit that accomplishes this is drawn in the figure shown. Basically, it is a voltage-controlled asymmetrical multivibrator with a minimum operating threshold given by:

$$V_{TH} = \frac{R_4 (R_1 + R_2)}{R_1 (R_3 + R_4)} V_{REF}$$

Above this threshold, the flash frequency increases with voltage. This is a far more noticeable indication of a deteriorating battery than merely dimming the LED. In addition, the indicator can be made visible with considerably less power drain. With the values shown, the flash rate is 1.4 sec -1 at 1.2 V with 300-µA drain and 5.5 sec -1 at 1.55 V with 800-µA drain. Equivalent visibility for continuous operation would require more than 5-mA drain.

BATTERY CHARGER PROBE

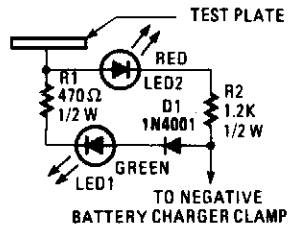

POPULAR ELECTRONICS

Fig. 14-4

This battery-charger probe can keep you from damaging batteries or yourself by testing to see if the charger is already on and/or connected improperly.

To use the probe, the positive cable clamp is first connected to the positive battery terminal. Then, the test plate is touched to the negative terminal of the battery. If the battery is connected properly, current will pass from the test plate through R1, LED1, D1, the negative charger, and into the positive side of the batteries. If LED1 (the green LED) lights, you can clamp on the negative lead and turn on the charger.

If the terminals are reversed, current will flow in the opposite direction, causing LED2 to light, warning you of danger. When the cable is reversed, D1 protects LED1 from excessive reverse voltage. If that happens, immediately turn the power off, and right the cable connections. Finally, if the battery charger is on, both LEDs will light because chargers actually produce pulsating dc and rely on the battery to act as a filter.

LOW-BATTERY CIRCUIT

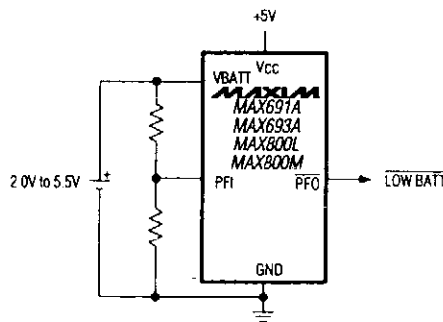

MAXIM

Fig. 14-5

A Maxim MAX691A series IC allows low-battery detection.

BATTERY CHARGE INDICATOR

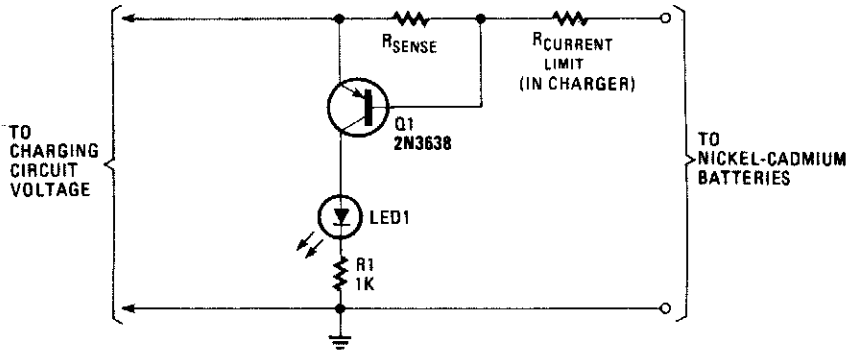

RADIO-ELECTRONICS

Fig. 14-6

When a battery is charging, a voltage drop across R_{SENSE} causes Q1 to conduct, and lights LED1. R_{SENSE} should be chosen as follows:

$$R_{\text{SENSE}} \text{ (ohms)} = \frac{0.65}{I_{\text{CHARGE}} \text{ (amps)}}$$

BATTERY STATUS INDICATOR

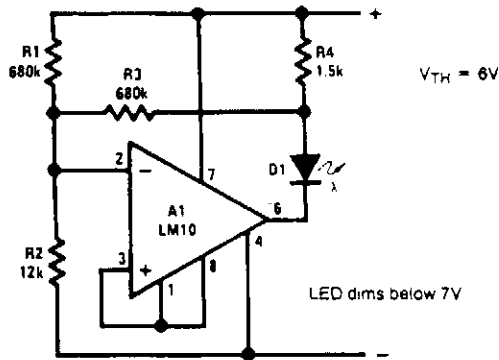

NATIONAL SEMICONDUCTOR

Fig. 14-7

In battery-powered circuitry, there are some advantages to having an indicator to show when the battery voltage is high enough for proper circuit operation. This is especially true for instruments that can produce erroneous data.

The battery status indicator is designed for a 9-V source. It begins dimming noticeably below 7 V and it extinguishes at 6 V. If the warning of incipient battery failure is not desired, R3 can be removed and the value of R_1 is halved.

LITHIUM MEMORY BACKUP BATTERY REPLACEMENT

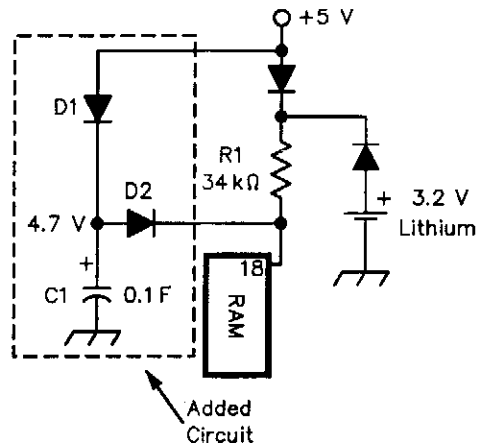

QST

Fig. 14-8

Physically very small high-capacitance capacitors are available for memory backup. Here, a 0.1-F (100,000 μF) capacitor and two diodes replace the lithium battery. The lithium battery can be retained as well, providing double backup.

BATTERY-CONDITION INDICATOR FOR 12-V BATTERIES

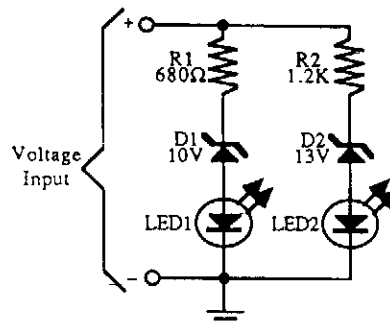

McGRAW-HILL

Fig. 14-9

A simple battery condition indicator. Choose the Zener diodes to provide a "window" for over/under voltage indication.

15

Bridge Circuits

The sources of the following circuits are contained in the Sources section, which begins on page 707. The figure number in the box of each circuit correlates to the entry in the Sources section.

Single-Supply Bridge Amplifier

Wheatstone Bridge

Bridge Amplifier with Low Noise Compensation

SINGLE-SUPPLY BRIDGE AMPLIFIER

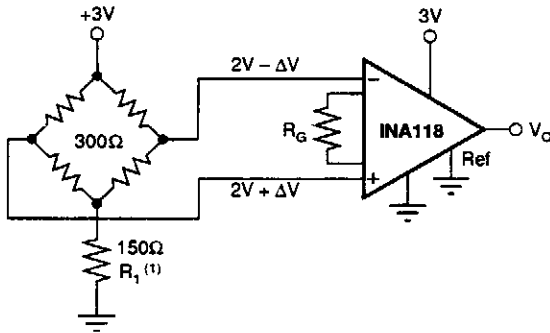

DESIRED GAIN	R_G (Ω)	NEAREST 1% R_G (Ω)
1	NC	NC
2	50.00k	49.9k
5	12.50k	12.4k
10	5.556k	5.62k
20	2.632k	2.61k
50	1.02k	1.02k
100	505.1	511
200	251.3	249
500	100.2	100
1000	50.05	49.9
2000	25.01	24.9
5000	10.00	10
10000	5.001	4.99

NOTE: (1) R_1 required to create proper common-mode voltage, only for low voltage operation — see text.

BURR-BROWN

Fig. 15-1

The INA118 can be used on single-power supplies of +2.7 to +36 V. The figure shown is a basic single-supply circuit. The output Ref terminal is connected to ground. Zero differential input voltage will demand an output voltage of 0 V (ground). Actual output voltage swing is limited to approximately 35 mV above ground, when the load is referred to ground as shown. The typical performance curve “Output Voltage vs. Output Current” shows how the output voltage swing varies with output current.

With single-supply operation, $+V_{IN}$ and $-V_{IN}$ must both be 1.1 V above ground for linear operation. You cannot, for instance, connect the inverting input to ground and measure a voltage connected to the noninverting input.

To illustrate the issues affecting low-voltage operation, consider the circuit in the figure. It shows the INA118, operating from a single 3-V supply. A resistor in series with the low side of the bridge ensures that the bridge output voltage is within the common-mode range of the amplifier's inputs.

WHEATSTONE BRIDGE

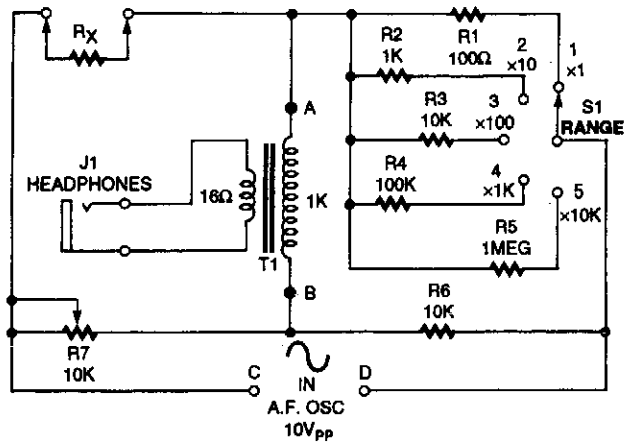

POPULAR ELECTRONICS

Fig. 15-2

This circuit can be used to measure resistances. R7 is calibrated and fitted with an indicator dial, then:

$$\frac{R_x}{(R_1 \text{ through } R_5)} = \frac{R_7}{R_6} \text{ or } R_x = \frac{R_7}{R_6} \times (R_1 \text{ through } R_5)$$

A frequency of 1 kHz for the audio oscillator is usually used.

BRIDGE AMPLIFIER WITH LOW NOISE COMPENSATION

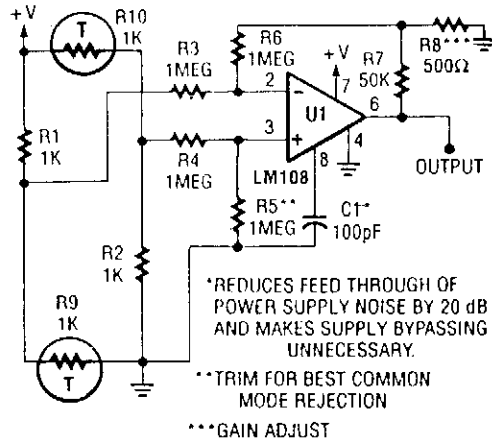

POPULAR ELECTRONICS

Fig. 15-3

16

Buffer Circuits

The sources of the following circuits are contained in the Sources section, which begins on page 707. The figure number in the box of each circuit correlates to the entry in the Sources section.

Unity-Gain ADC Buffer
HI-Z Microphone Buffer Amplifier
Wideband General-Purpose Buffer
ADC Buffer
Single-Supply ac Buffer Amplifier
Analog Noninverting Switched Buffer
Voltage Follower
Simple Bidirectional Buffer Design
Buffer for A/D Converters

UNITY-GAIN ADC BUFFER

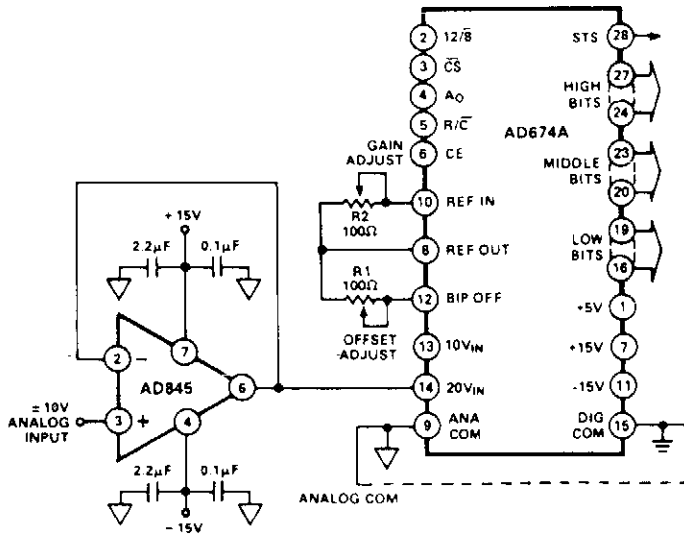

ANALOG DEVICES

Fig. 16-1

This buffer is suitable for ADCs of 12 bits with conversion times of 5 μ s or greater. The wide bandwidth of the AD845 ensures a low output impedance at higher frequencies in the voltage follower (buffer) configuration.

HI-Z MICROPHONE BUFFER AMPLIFIER

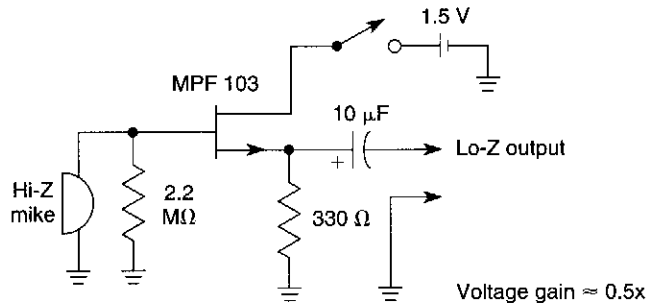

WILLIAM SHEETS

Fig. 16-2

A low impedance output from a high-Z microphone can be obtained with this circuit. No voltage gain is obtained, but a power gain is obtained because the output impedance is much lower (300 Ω), with -6-dB voltage gain.

WIDEBAND GENERAL-PURPOSE BUFFER

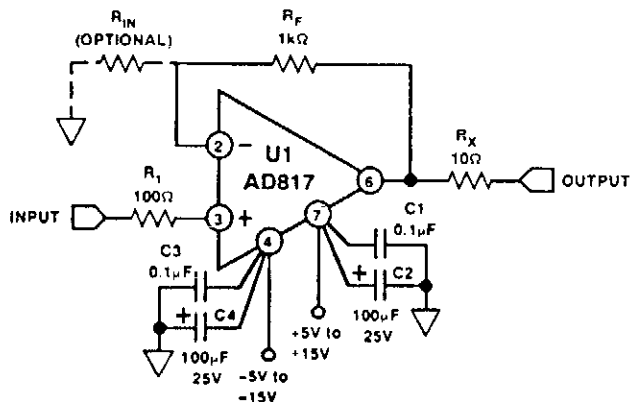

ANALOG DEVICES

Fig. 16-3

This circuit has unity gain and response up to 70 MHz. U1 is an Analog Devices AD817.

ADC BUFFER

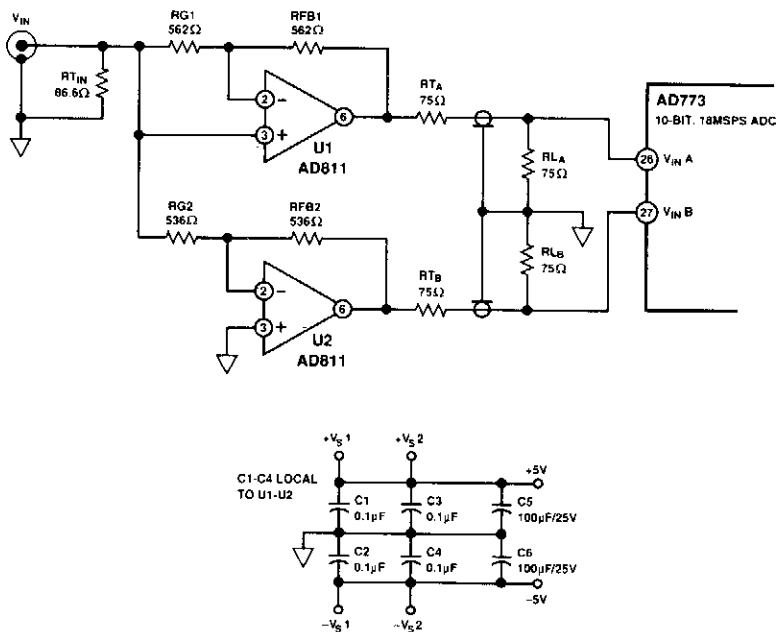

ANALOG DEVICES

Fig. 16-4

Useful for driving high-speed, 10-bit ADCs, this circuit was developed to drive an 18-MSPS 10-bit ADS. It works from ± 5 -V supplies.

SINGLE-SUPPLY ac BUFFER AMPLIFIER

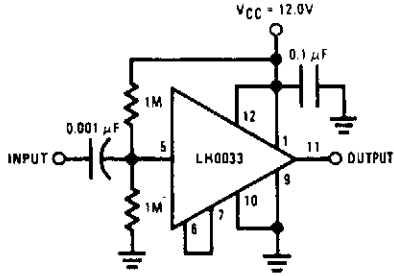

This buffer might be used with a single supply without special considerations. The input is dc biased to mid-operating point and is ac coupled. Its input impedance is approximately 500 kΩ at low frequencies. Note that for dc loads referenced to ground, this quiescent current is increased by the load current set at the input dc bias voltage.

NATIONAL SEMICONDUCTOR

Fig. 16-5

ANALOG NONINVERTING SWITCHED BUFFER

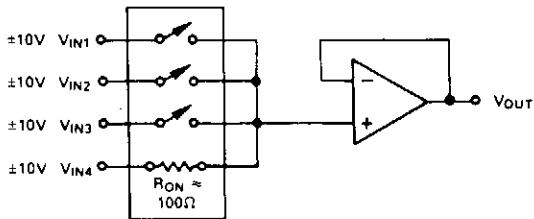

Here is noninverting solution.

ANALOG DEVICES

Fig. 16-6

VOLTAGE FOLLOWER

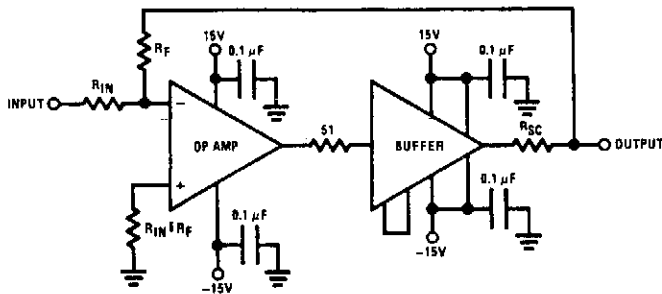

Op Amp	Recommended Buffer
LM101, LM108, LM741, LF151	LH0002
LH0022, LH0042, LH0052	
LF155, LF156, LF157, LH0024, LH0032	LH0033
LH0024, LH0032	LH0063

$R_{SC} \leq \frac{V_S}{I_{SC}}$

NATIONAL SEMICONDUCTOR

Fig. 16-7

SIMPLE BIDIRECTIONAL BUFFER DESIGN

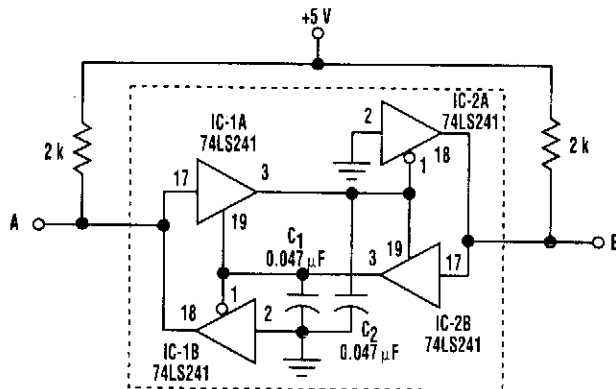

ELECTRONIC DESIGN

Fig. 16-8

This circuit shown in the figure uses two 74LS241s. When both input/output lines are high, IC-1A and IC-2B turn on, and C1 and C2 are charged to high voltage. Meanwhile, IC-1B and IC-2A are off to prevent a logic "1" latch.

BUFFER FOR A/D CONVERTERS

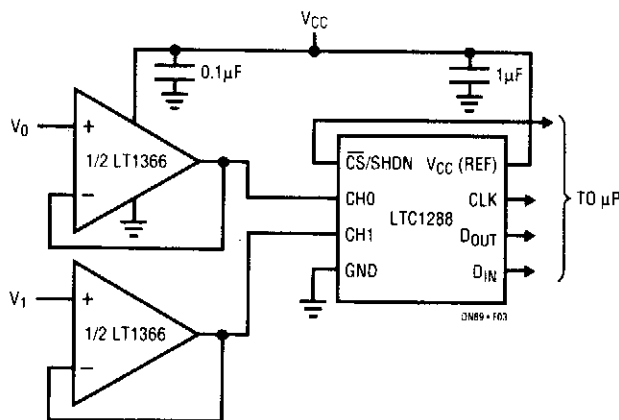

LINEAR TECHNOLOGY

Fig. 16-9

This circuit uses an LT1366 driving an LTC1288 two-channel micropower A/D. The LTC1288 can accommodate voltage references and input signals equal to the supply rails. The sampling nature of this A/D eliminates the need for an external sample-and-hold, but might call for a drive amplifier because of the A/D's 12- μ s settling requirement. The LT1366's rail-to-rail operation and low-input offset voltage make it well suited for low-power, low-frequency A/D applications. In addition, the op-amp's output settles to 1% in response to a 3-mA load step through 100 pF in less than 1.5 μ s.

17

Clock Circuits

The sources of the following circuits are contained in the Sources section, which begins on page 707. The figure number in the box of each circuit correlates to the entry in the Sources section.

Set Time Windows within a Clock
Low-Frequency Clock

SET TIME WINDOWS WITHIN A CLOCK

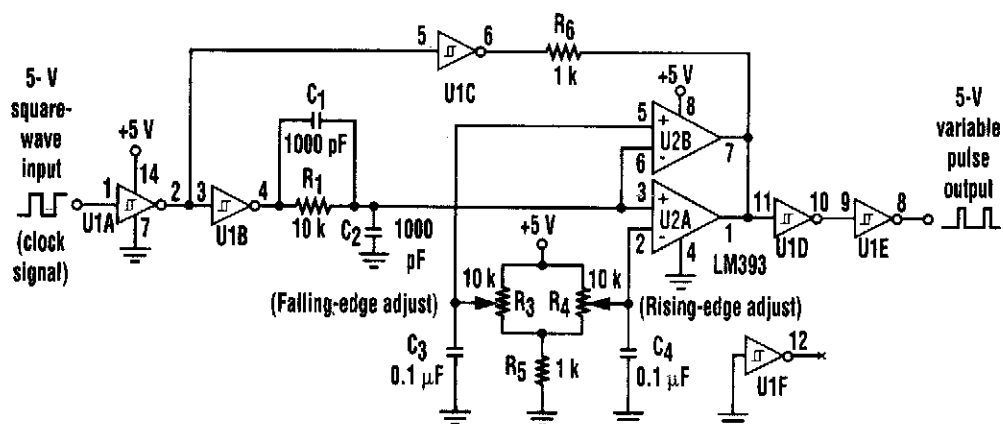

ELECTRONIC DESIGN

Fig. 17-1

At times, it is necessary to produce pulses of adjustable width and whose start times might vary with reference to a master clock. The input signal is inverted and buffered by U1A, while U1B and U1C reinvert the signal to produce square, buffered renditions of the input signal. Potentiometers R3 and R4 set references for the comparators.

The input polarity of U2A keeps its output transistor turned on until the voltage at the noninverting input exceeds the reference set by R4 (the rising edge adjustment). When this reference voltage is exceeded, the output transistor is turned off and the output signal is pulled up via R6. Meanwhile, the input polarity of U2B keeps its output transistor turned off until the voltage at the inverting input exceeds the reference set by R3 (the falling edge adjustment). When this reference voltage is surpassed, the output transistor of U2B is turned on, pulling the output signal low through the wired-OR configuration of U2. The output of U2 is then double-inverted and buffered by U1D and U1E. What results is a pulse whose start time (rising edge) can be adjusted by R4, and whose stop time (falling edge) can be adjusted by R3.

The output of the comparators is pulled up to the input waveform through resistor R6 to U1C. This prevents the comparators from switching during the low cycle of the input waveform, regardless of the positions of R3 and R4. This has the effect of "locking out" changes during the low period of the input signal, and would probably require additional logic if it were done strictly in the digital domain.

The circuit, with the component values shown, works well between about 50 and 150 kHz.

LOW-FREQUENCY CLOCK

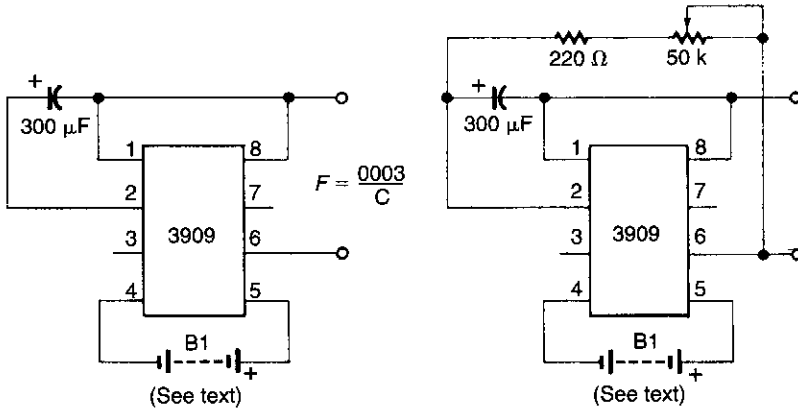

ELECTRONICS NOW

Fig. 17-2

The LM3909 is an LED flasher IC that is designed to oscillate at low frequencies. The clock output of the first circuit can be changed by changing the value of the capacitor, and the second circuit lets you adjust the frequency with the trimmer. B1 can be one or two alkaline 1.5-V cells. The LM3909 can supply up to 45-mA pulses at greater than 2 V.

18

Computer-Related Circuits

The sources of the following circuits are contained in the Sources section, which begins on page 707. The figure number in the box of each circuit correlates to the entry in the Sources section.

RS-422 to RS-232 Converter
Printer Port
PC Password Protector
Key Wireless RTS with Data
Microprocessor Supervisory Circuit
Computer-Powered RS-232
+12-V Flash Memory Programming Supply
EEPROM Programming Doubler Circuit
Monitor Power Saver for Computers

RS-422 TO RS-232 CONVERTER

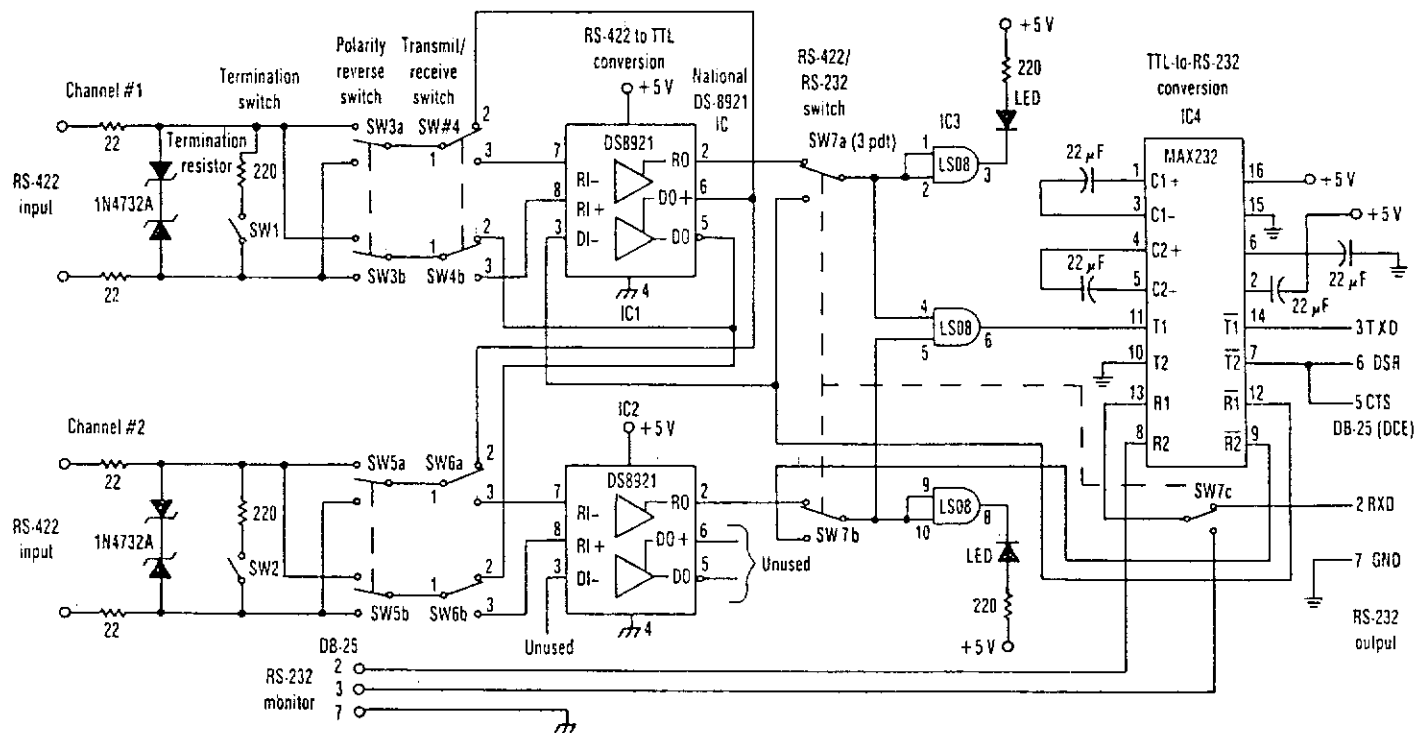

ELECTRONIC DESIGN

Fig. 18-1

The circuit supplies two LEDs for visual indication of line activity and terminating resistors when needed. The 220-Ω resistors and 5-V zeners at the RS-422 line inputs supply circuit protection.

Switch SW7 allows the circuit monitor both transmitted and received signals when tee-connected into an RS-232 line. One function of this optional feature is the ability to test a software-locking device that connects to the COM1 port on an IBM PC.

PRINTER PORT

REGISTER SELECTION CODES	
Data	Selected resistor
0X00	R ₁
0X01	R ₂
0X02	R ₃
0X03	R ₄
0X04	R ₅
0X05	R ₆
0X06	R ₇
0X07	R ₈
0X08	R ₉
0X09	R ₁₀
0X0A	R ₁₁
0X0B	R ₁₂
0X0C	R ₁₃
0X0D	R ₁₄
0X0E	R ₁₅
0X0F	R ₁₆

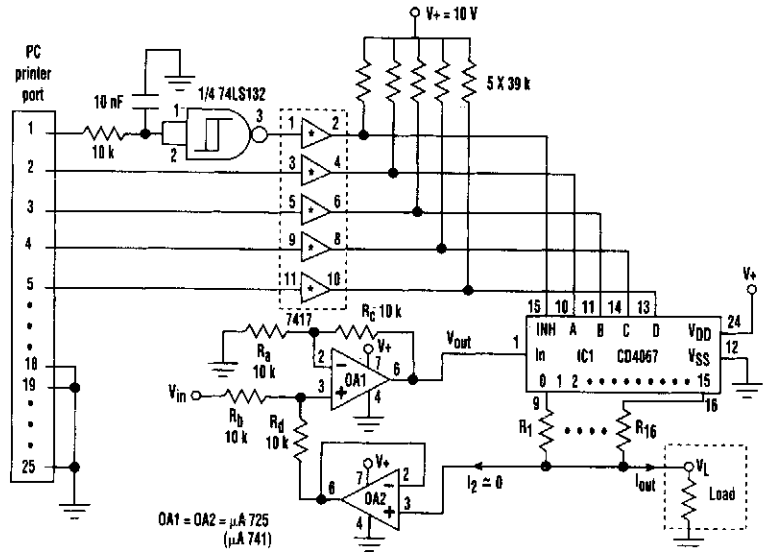

Fig. 18-2

ELECTRONIC DESIGN

A 16-step programmable current generator can be modified so that it's controllable by a printer port. This is done by switching the resistor connected between the output of the generator's OA1 op amp and the input of OA2. The CMOS single 16-channel analog multiplexer (IC1) chooses one resistor at a time, in accordance with the code sent by the printer port through four of its eight data-output lines (pins 2 to 9). In addition, one control line (pin 1) is used to enable the operation. As a result, 16 outputs can be selected by a 4-bit word (the table shows the relationship between data word and selected resistor).

The following must be fulfilled in order for the circuit to work as a true current generator:

$$R_2 \times R_d - R_b \times R_c = 0$$

The smaller the resistors' tolerance (especially R1 through R16), the greater the output resistance of the generator.

Because the OA2 is connected as a repeater, the current $I_2 = 0$, and only the load current flows through one of the R1 through R16 resistors. Therefore:

$$I_{out} = \frac{V_{out}}{(R_x + R_{on})}$$

PRINTER PORT (Cont.)

where $V_{out} = V_{in}$; $X = 1...16$; and $R_{on} \leq 150 \Omega$ (for $V_{DD} = 10 \text{ V}$) is the resistance of one analog switch (CD4067) in conduction.

Therefore, the values of resistors R_1 through R_{16} can be inferred from the needed currents:

$$R_x = \left(\frac{V_{in}}{I_{out}} \right) - R_{on}$$

The Turbo C++ program also controls the current through the load.

TURBO C++ CONTROL PROGRAM

```
#include <stdio.h>
#include <dos.h>

#define OUT_PORT 0x378 /*printer output port address */
#define CTRL_PORT 0x37A /*printer control port address */

int main(void)
{
    int data;
    outport(CTRL_PORT , 0x01); // enable operation
    delay(1);
    outportb(OUT_PORT) , data); // one of R1 -R16 selected (table)
    printf("\n\naR%d selected.",data+1);
    return 0;
}
```

PC PASSWORD PROTECTOR

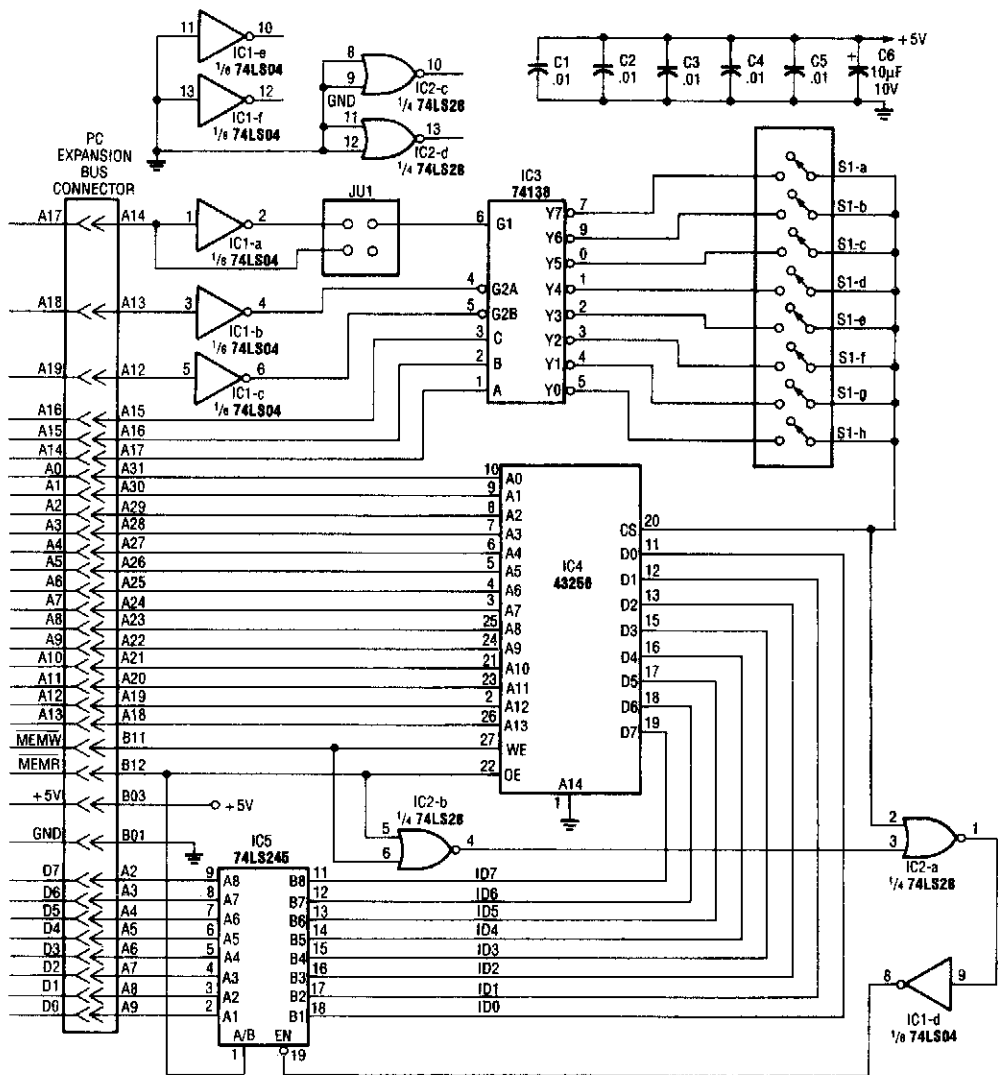

IC4, a static RAM, is mounted in a "smart" built-in switch over circuitry. This retains SRAM contents when power is off. The rest of the circuitry consists of address decoding logic and jumper JU1, used to decode a 16K address space for the 32K static RAM. Software is necessary and this is contained in the original article (see reference).

KEY WIRELESS RTS WITH DATA

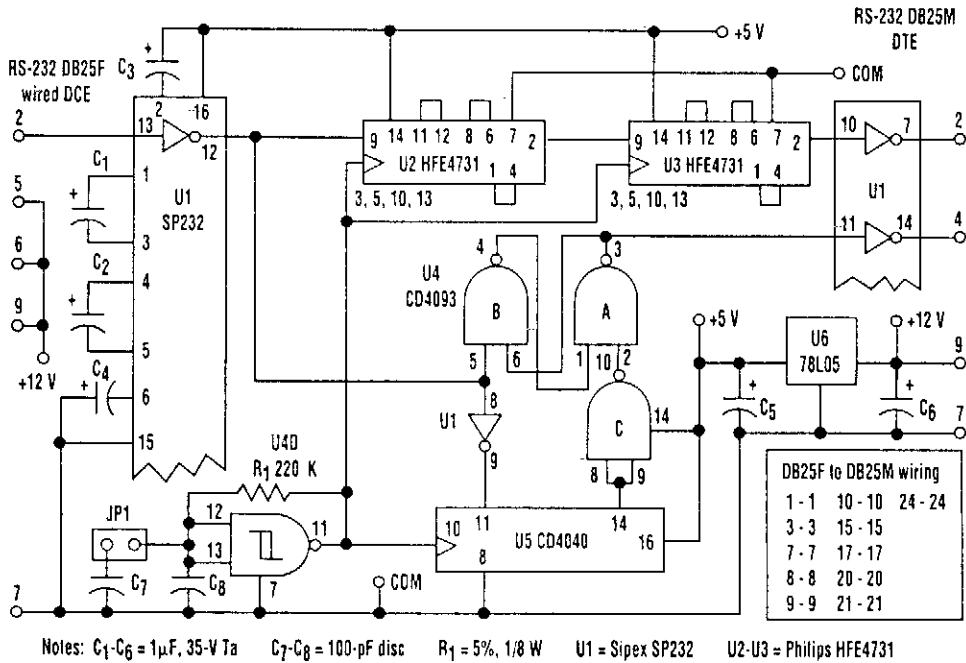

ELECTRONIC DESIGN

Fig. 18-4

This simple keyer supplies both the RTS control and data delay needed to interface a digital radio with an RS-232, data-only system. It supports speeds to 19.2 kbits/s sync or async.

MICROPROCESSOR SUPERVISORY CIRCUIT

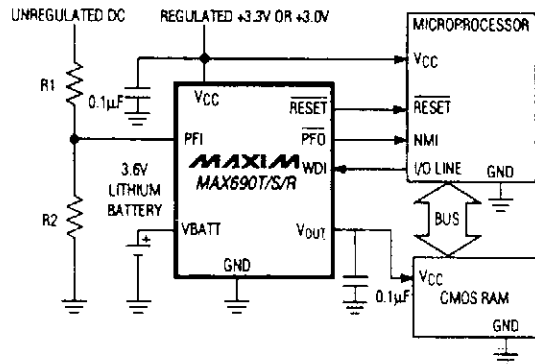

MAXIM

Fig. 18-5

This circuit provides a reset pulse during power up, down, or low-voltage battery back up, switching, a watchdog timer and a 1.25-V threshold detector for power failure or power fail warning, or to monitor another supply.

COMPUTER-POWERED RS-232

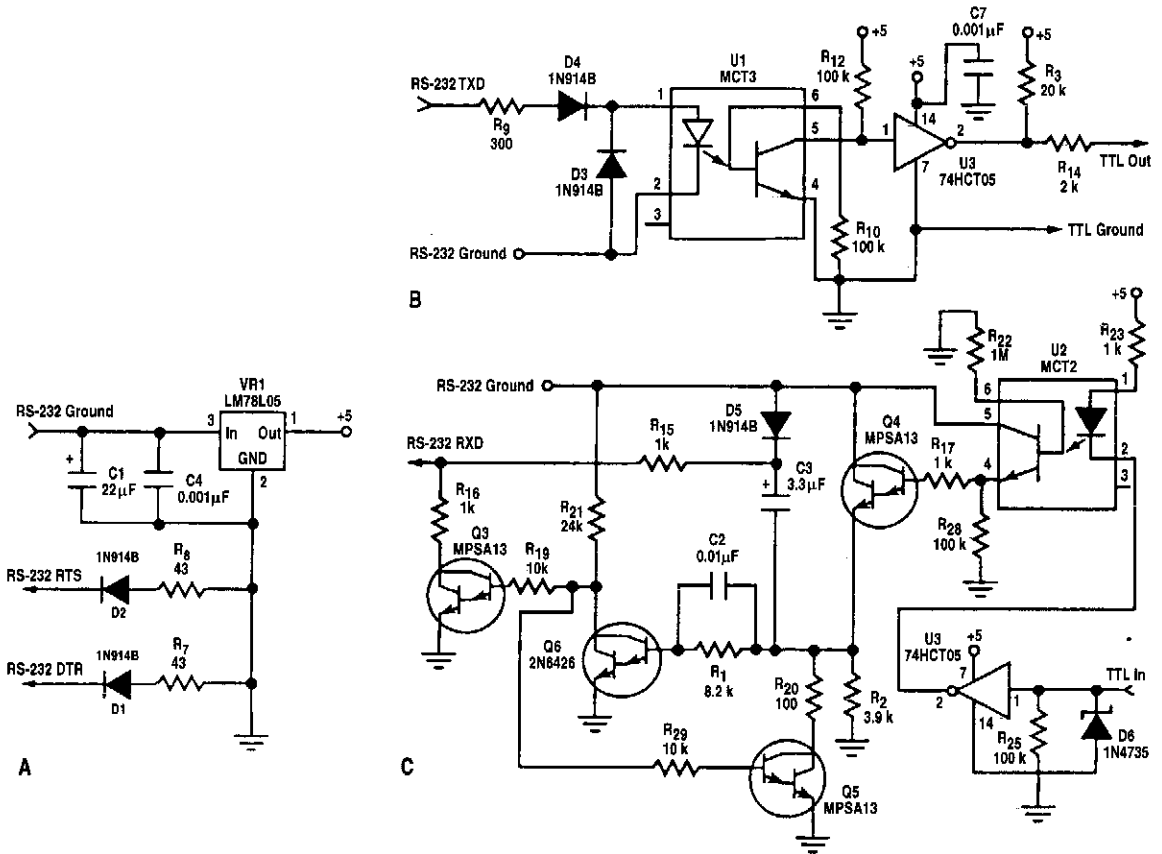

COMPUTER-POWERED RS-232 (Cont.)

Commercializing battery-operated equipment that must interface to a computer via the RS-232 port runs into the problem of power consumption. To load the system batteries strictly to power the interface is unacceptable. An alternative is to let the computer that the device is connected to provide the interface's power. One snag is that the RS-232 specification doesn't have a power tap on the connector, but it does provide RTS and DTR (request to send and data terminal ready) signals that assert a negative voltage in their quiescent state.

Figure 18-6A shows a simple scheme of deriving a 5-V potential from the RTS and DTR signals. R7 and R8 and diodes D1 and D2 mix the return current to the RS-232 port so that the RTS and DTR drivers split the current drawn by the interface. This scheme, even from a laptop-computer, can supply 12 mA to the interface. The only drawback is that the TTL device must be isolated from the computer's ground (earth ground) because the interface treats the RS-232 ground as a positive voltage.

A modified optocoupler system shifts the RS-232 level to TTL voltages (Fig. 18-6B). It will support up to 9600 bits/s. C3 is charged up to about 1 V less than the RTS voltage while the TTL line asserts a marking state. As the capacitor is charging, Q3 is biased into saturation, thus providing a negative voltage (with respect to RS-232 ground) to the RS-232 RXD line. When a spacing bit is driven from the TTL line, Q3 switches off and Q4 switches on. This biases Q4's emitter up to the RS-232 ground. That ground potential is summed with C3's charge to create an RS-232-compatible spacing signal (approximately 1 V less than a $-V_{RTS}$).

The discharge rate on C3 is limited by R15 to prevent the signal sag from becoming a problem down to 110 bits/s. The C2/R1 time constant must be fairly close (within 4 times) to the C3/R15 time constant to ensure that Q3 turns off correctly.

+12-V FLASH MEMORY PROGRAMMING SUPPLY

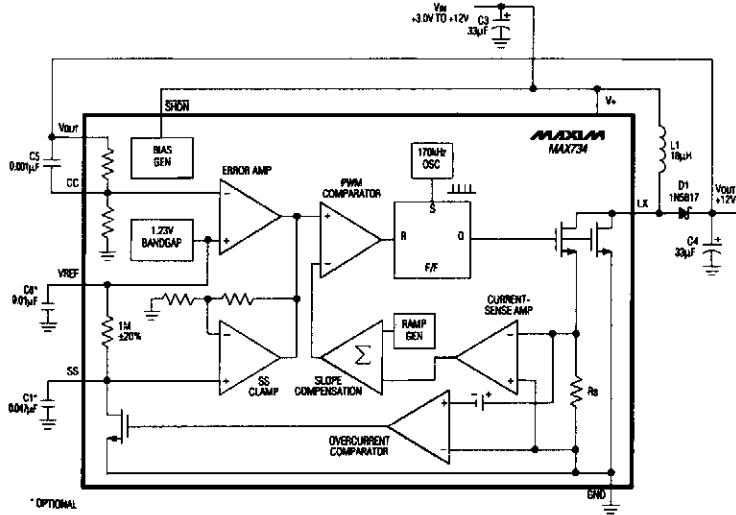

Fig. 18-7

MAXIM

The MAX734 can deliver up to 120 mA @12 V from a +5-V supply, using few external components. This supply can also be used for other applications than memory programming. A logic level is used for shutdown. Efficiency is about 85%.

EEPROM PROGRAMMING DOUBLER CIRCUIT

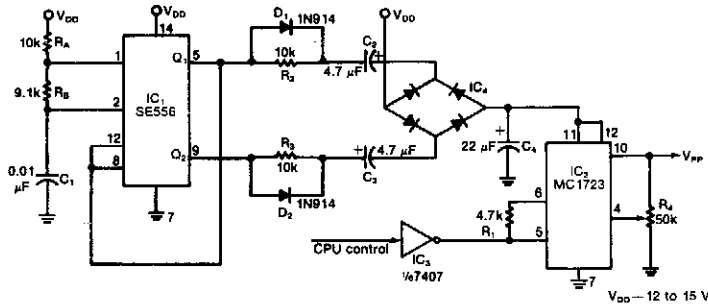

Fig. 18-8

ELECTRONIC DESIGN

Even though electrically erasable PROMs offer the convenience of single-byte write and erase operations, the parts require a somewhat nonstandard programming voltage—21 V. A simple circuit that develops the appropriate voltage from a computer system's standard 12-to-15-Vdc supply, remedies the problem nicely. Moreover, it permits the programming voltage to be pulsed under the control of an external CPU.

As shown in the figure, the chip uses its complementary outputs, Q1 and Q2 to trigger a bridge rectifier through capacitors C2 and C3. Resistors R2 and R3 and diodes D1 and D2 limit the current and protect IC1 from spikes from C2 and C3. If required, the regulator will deliver up to 150 mA.

Circuit IC3 is an open-collector TTL gate whose output, when low, disables IC2 and causes it to put out 5 Vdc. The regulator delivers the 21-V programming pulse.

MONITOR POWER SAVER FOR COMPUTERS

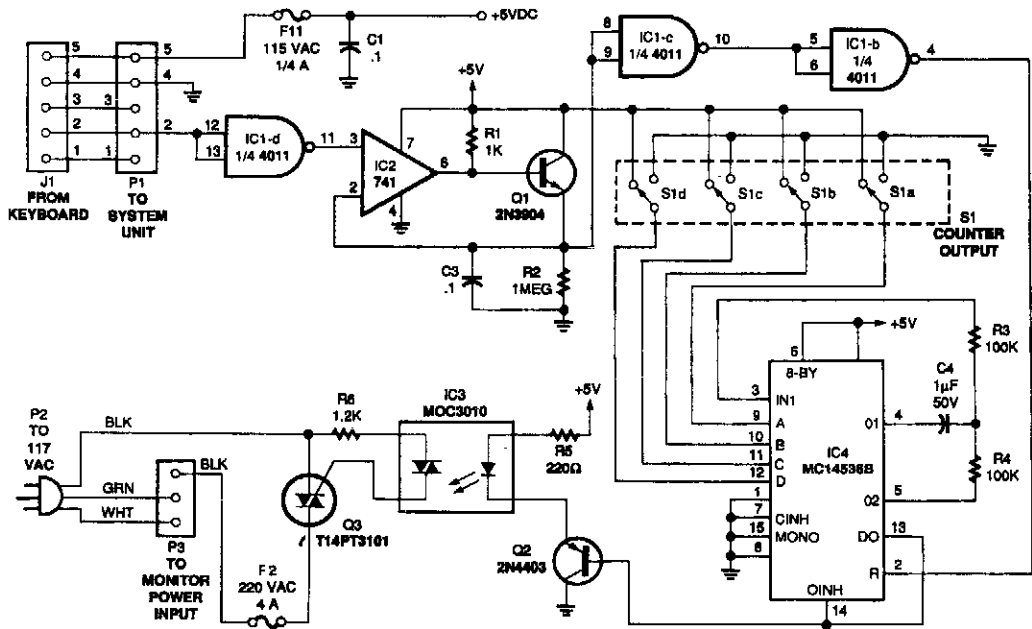

ELECTRONICS NOW

Fig. 18-9

The circuit monitors PC keyboard activity through five-pin DIN connector J1. When the user presses a key, the keyboard sends a series of negative-going pulses on pin 2. In conjunction with Q1 and C3, the op amp essentially functions as an integrator, which stretches the continually varying periods of the input pulses to a relatively constant period with a higher average dc value.

Inverters IC1-c and IC1-b buffer the peak detector's output to trigger IC4, an MC14536B programmable timer.

19

Continuity Circuits

The sources of the following circuits are contained in the Sources section, which begins on page 707. The figure number in the box of each circuit correlates to the entry in the Sources section.

Short-Circuit Beeper
Adjustable Continuity Tester
Simple Audio/Video Cable Tester
Audible Continuity Tester

SHORT-CIRCUIT BEEPER

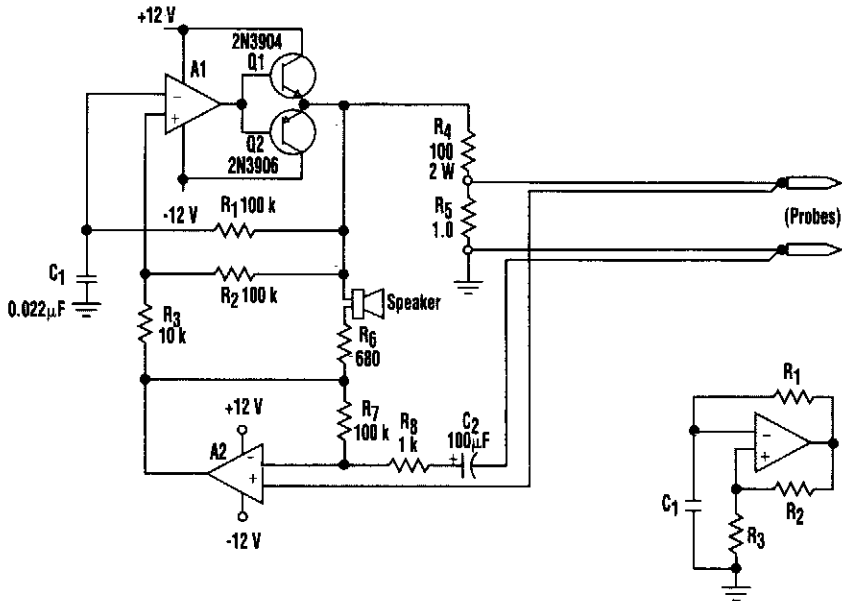

Fig. 19-1

ELECTRONIC DESIGN

This design offers a way to trace resistance in the milliohm range, right to a short between bridged traces beneath a solder mask. It simply translates resistance into an audible tone, which increases in pitch as the measured value approaches zero.

In the classic op-amp multivibrator (shown in the inset), oscillation frequency is determined not only by the $R1/C1$ time constant, but also by the hysteresis set by the $R2/R3$ resistance ratio. A1 in the main figure, with current boosters Q1 and Q2, is this same configuration.

Assuming a virtual ground at the output of A2, free-run frequency is about 1 kHz—quite audible through a tiny 8- Ω speaker. Q1 and Q2 deliver a ± 10 -V squarewave to R4, dumping a ± 100 mA through a short circuit placed across the probe tips. R5 ensures that open circuit voltage never exceeds ± 0.1 V.

A2 monitors the voltage between the probes. The differential input must have its own separate path to the probe tips to eliminate test lead resistance from the measurement. Miniature “zip-cord” sold as loudspeaker wire makes a tidy two-conductor test lead.

When the probes are open, A2’s gain equals the $R4/R5$ divider loss, and the output of both amplifiers is identical. This has two effects: first, hysteresis is greatly increased and the frequency falls to a low growl; second, the loudspeaker that bridges the two in-phase outputs is effectively silenced.

The dead short across the probe tips will return nothing to A2 and the circuit will squeal at its nominal 1-kHz rate. Anything less than a perfect short produces some output from A2, increasing multivibrator hysteresis and lowering the pitch. The circuit has so much “leverage,” and the ear is so sensitive to pitch changes in this range, that it’s easy to resolve minute resistance differences.

Any general-purpose op amp will suffice in this circuit—a couple of 741s or an equivalent dual.

ADJUSTABLE CONTINUITY TESTER

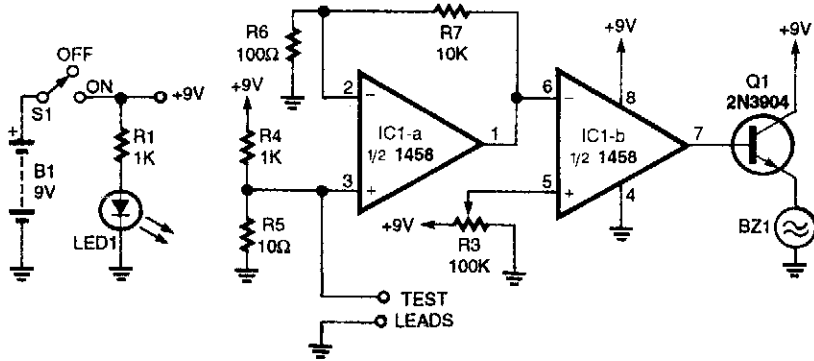

ELECTRONICS NOW

Fig. 19-2

A problem with most continuity testers is that the exact decision point (circuit resistance) between continuity and open is indefinite. This circuit allows setting of this point to a known resistance between 1 and 50 Ω .

SIMPLE AUDIO/VIDEO CABLE TESTER

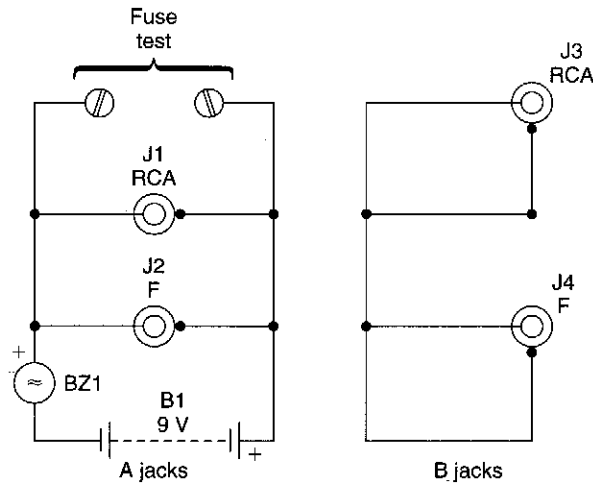

ELECTRONICS NOW

Fig. 19-3

As simple as it looks, the audio/video cable tester tests cables while they are plugged in. You can flex them vigorously while listening to the built-in buzzer.

Simply plug the ends of the cable in the appropriate jack. Only one end of the cable need be plugged in for a complete short test; the other end is left free. If the buzzer sounds, there is a short circuit somewhere in the cable. If nothing is heard, test for an intermittent short by flexing the cable several times, particularly in the plug area of both the free and plugged-in ends.

AUDIBLE CONTINUITY TESTER

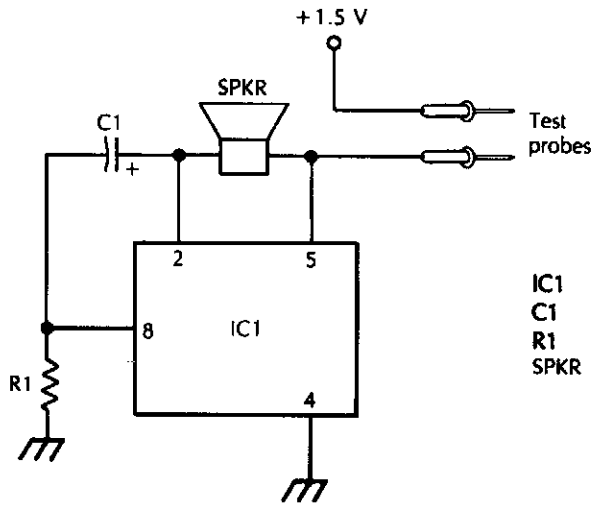

- IC1 LM3909 LED flasher/oscillator IC
- C1 10 μ F 10 V electrolytic capacitor
- R1 1 k Ω 1/4 W 5% resistor
- SPKR Small 8 Ω speaker

McGRAW-HILL

Fig. 19-4

20

Converter Circuits

The sources of the following circuits are contained in the Sources section, which begins on page 707. The figure number in the box of each circuit correlates to the entry in the Sources section.

- WWV Converter
- Simple HF Receive Converter
- 225-W, 15-V Output Converter
- 12-Bit DAC
- Driven Flyback Converter
- Sine-Wave Converter
- SCR Converter
- 5-V, 5-A Step-Down Converter
- Sync-to-Async Converter
- Differential Voltage-to-Current Converter
- Direct-Conversion 7-MHz Receiver
- Low-Frequency Converter
- Programmable Current-to-Voltage Converter
- Current-to-Voltage Converter with Boost Transistor
- Current-to-Voltage Converter for Grounded Loads
- Output-to-Current Converter

WWV CONVERTER

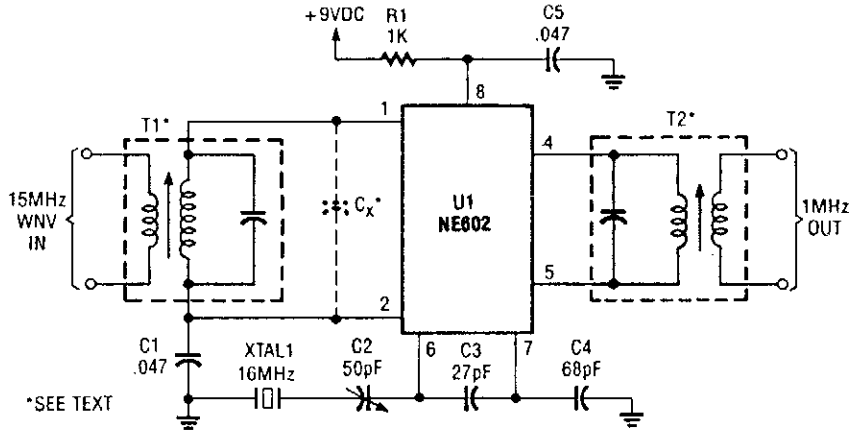

RADIO CRAFT

Fig. 20-1

This converter heterodynes the 15-MHz WWV signal with a 16-MHz oscillator so that it can be heard at 1 MHz on an AM broadcast receiver. T1 and T2 are a modified 10.7-MHz IF transformer and AM BC oscillator coil, respectively.

SIMPLE HF RECEIVE CONVERTER

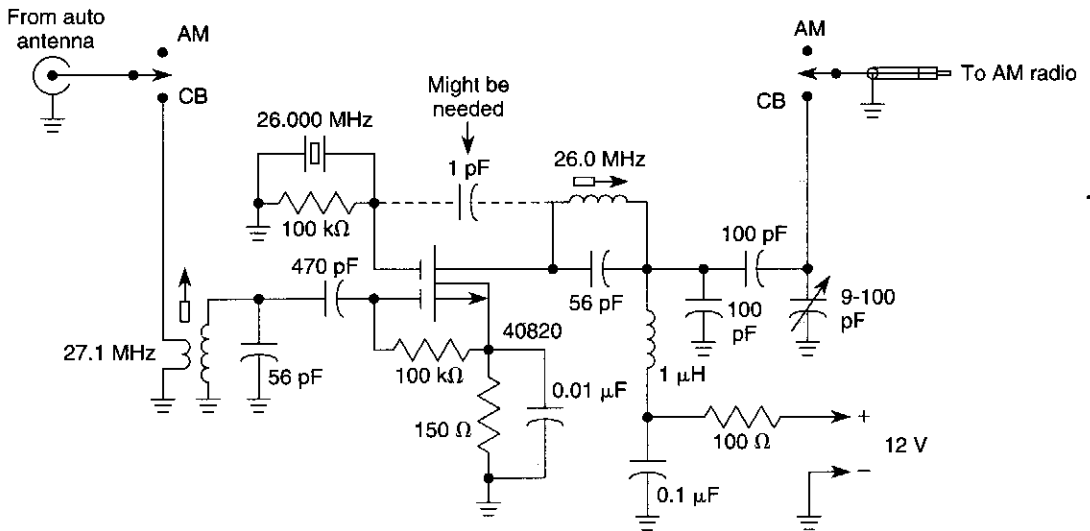

WILLIAM SHEETS

Fig. 20-2

Designed for CB reception, this crystal-controlled converter uses one 40820 dual-gate MOSFET. The circuit will work with any crystal either 3rd overtone or fundamental, over 1 to 50 MHz.

225-W, 15-V OUTPUT CONVERTER

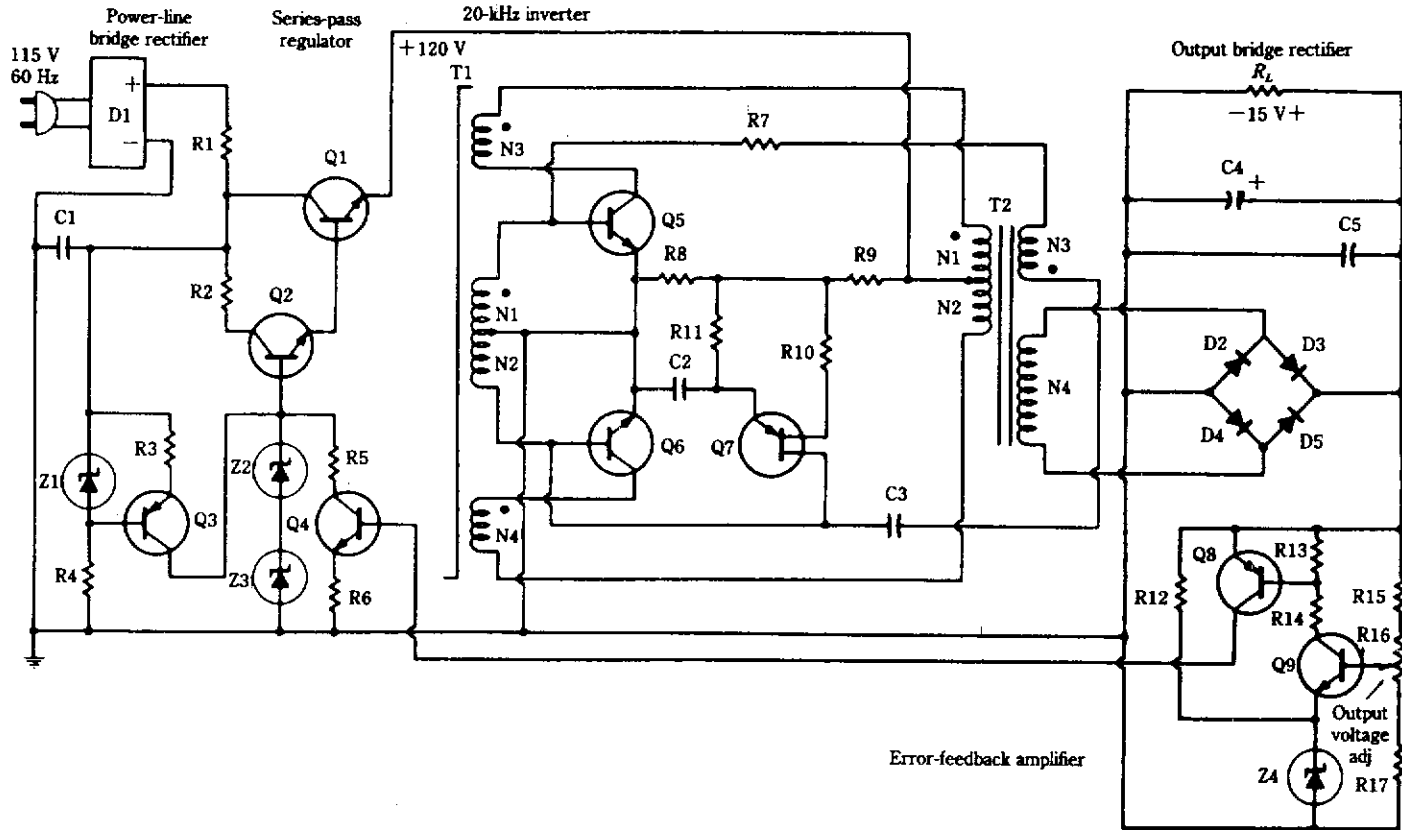

McGRAW-HILL

Fig. 20-3

A converter designed to supply ± 15 Vdc is shown. This converter is several times lighter in weight than an equivalent.

225-W, 15-V OUTPUT CONVERTER (Cont.)

C1 — 2500 μ F, 350 V Electrolytic	Q1, Q5, Q6, — 2N6307
C2 — 0.1 μ F Disc Ceramic	Q2, Q4 — 2N5052
C3 — 0.1 μ F Paper	Q3 — 2N5345
C4 — 10 μ F Electrolytic	Q7 — 2N4870
C5 — 0.25 μ F Paper	Q8 — 2N3905
D1 — MDA-980-4 Bridge Rectifier Assembly	Q9 — 2N3903
D2, D3, D4, D5 — 1N5826, 20 V 15 A	

All Resistors in Ohms and 1/2 W Unless Otherwise Noted

R1 — 1, 10 W	R10 — 1K
R2 — 100	R11 — 10K
R3 — 82	R12 — 270
R4 — 22K	R13 — 1K
R5 — 1.5K, 15 W	R14 — 7.5K
R6 — 200	R15 — 2.5K
R7 — 15	R16 — 5K
R8 — 4.7K	R17 — 3.5K
R9 — 51	

T1 — Core — Magnetics Inc. 80623 — 1/2 D — 080

N1, N2 — 20 Turns Each, No. 30 AWG (Bifilar)
 N3, N4 — 3 Turns Each, No. 20 AWG

T2 — Core — Arnold 6T 5800 D1

N1, N2 — 100 Turns Each, No. 20 AWG (Bifilar)
 N3 — 7 Turns No. 26 AWG
 N4 — 12 Turns Each, No. 12 AWG (No. 16 AWG, 3 in Parallel)

Z1 — 1N4733, 5.1 V
 Z2, Z3 — 1N4760, 68 V
 Z4 — 1N4736

12-BIT DAC

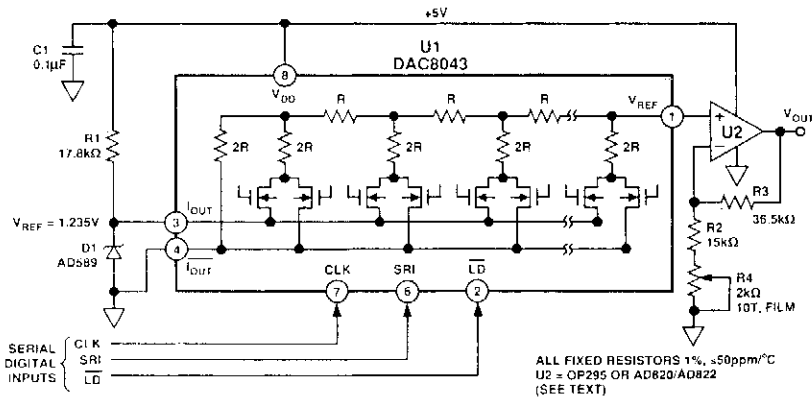

ANALOG DEVICES

Fig. 20-4

This circuit uses an Analog Devices DAC-8043 12-bit multiplying DAC. The output voltage will be $D/4096 \times V_{ref}$, where D is the numerical value of the digital input word (0 to 4095). V_{ref} is 1.235 volts in this circuit.

DRIVEN FLYBACK CONVERTER

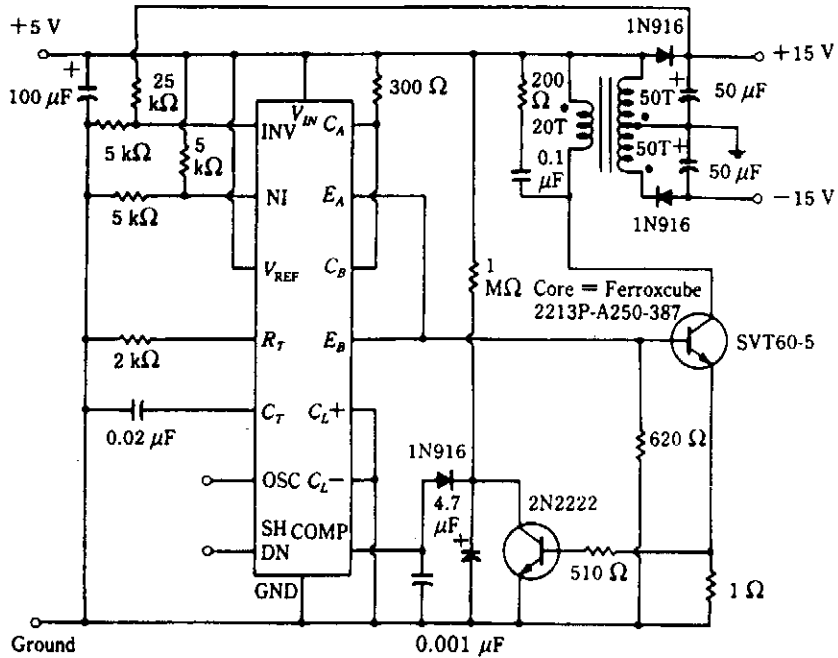

McGRAW-HILL

Fig. 20-5

This circuit uses an SG1524 Silicon General regulating pulse width modulator and provides ± 15 V from a 5-V supply rail.

SINE-WAVE CONVERTER

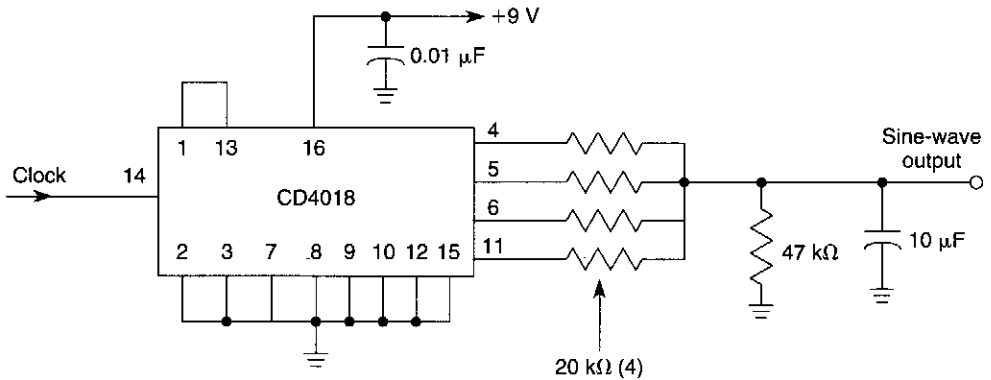

WILLIAM SHEETS

Fig. 20-6

This circuit produces a sine wave with a low-frequency clock input. The clock rate should be 100 Hz or less.

SCR CONVERTER

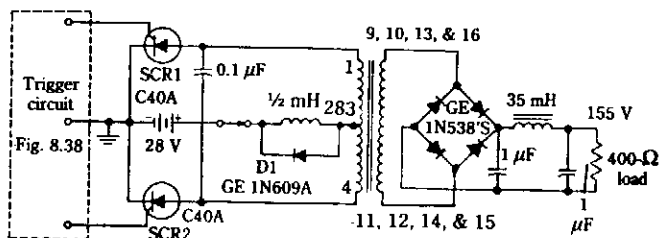
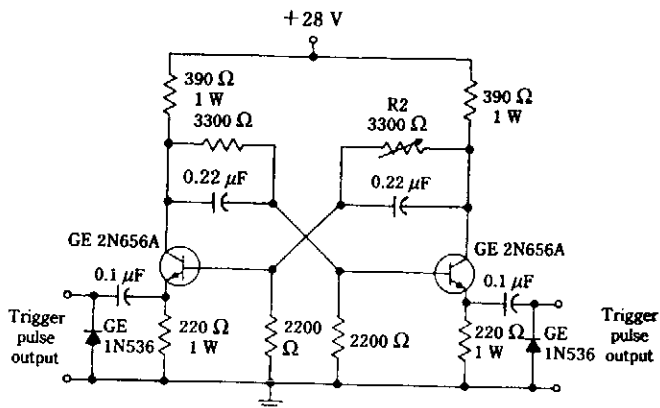

McGRAW-HILL

Fig. 20-7

Two SCR devices are used in a push-pull driver to convert 28 Vdc to 155 Vdc, using the transformer and bridge shown. A center-tapped transformer with 24 V:120 V could be used for 60-Hz applications. The trigger circuit supplies a push-pull drive signal.

5-V, 5-A STEP-DOWN CONVERTER

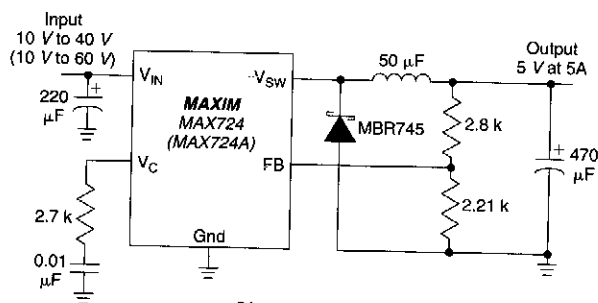

5A step-down converter

MAXIM

Fig. 20-8

This circuit is useful where power must be distributed by a higher (10 to 60 V) bus. The circuit reduces power dissipation and eliminates inefficient passive linear regulators. The switching frequency is in the 100-kHz region.

SYNC-TO-ASYNC CONVERTER

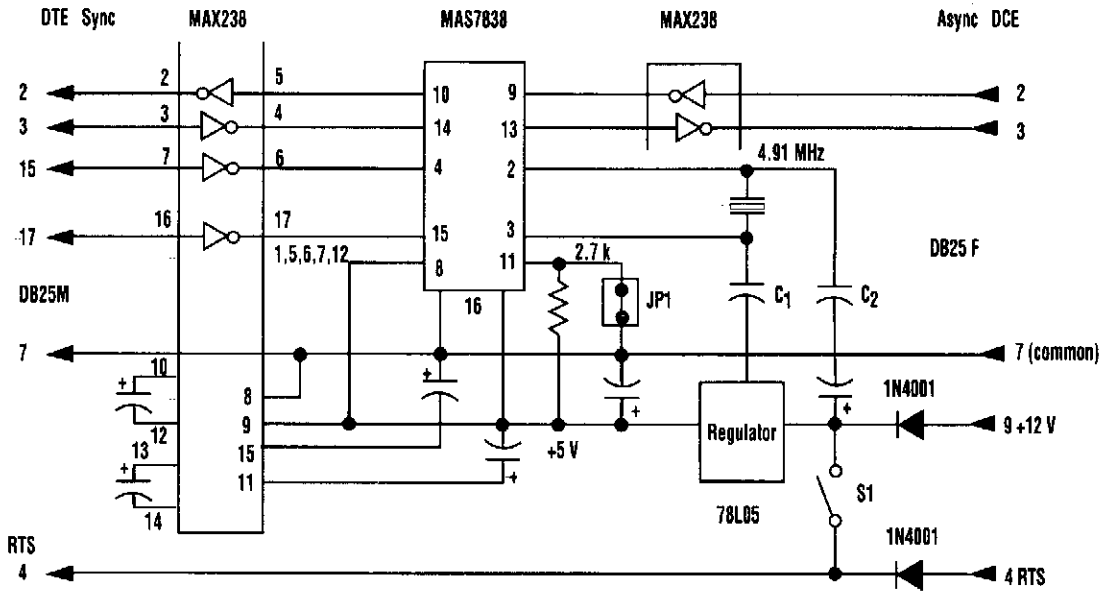

Point-to-point adapter wiring

1.....	1
5.....	5
6.....	6
7.....	7
8.....	8
9.....	9
10.....	10
15.....	15
17.....	17
20.....	20
21.....	21
24.....	24

Notes:

- Maxim RS232 interface: MAX238
- Sipex A/S converter: MAS7838
- Generic regulator: 78L05
- C₁ and C₂ = 20-pF disk-type; other capacitors (6) = 1 μF, 35 V
- Resistor = 1/8 W, 5%

This simple converter consists of two ICs and a voltage regulator. The Sipex MAS7838, which acts as the converter, selects the conversion speed to that of the synchronized data clock. It has internal switches and registers to perform the async-to-sync, or sync-to-async, conversion. The Maxim MAX238 provides the RS-232 drivers and receivers for interfacing with the data bus. These chips require a 5-Vdc power supply; a generic 78L05 reduces the +12 V at the DB25 pin 9 to the +5 V needed. A crystal frequency of 4.91 MHz is suitable for converting to 19.2 kbits or a sub-multiple (9.6, 4.8, 2.4, etc.). Two 1N4001 diodes protect the external RTS (ready to send) control circuitry if the RTS is enabled by S1. When JP1 is removed, the converter is transparent in the sync mode and no conversion will occur.

The completed unit is mounted atop a universal breakout adapter, and the control lines are jumpered according to the chart in the figure. The physical size is approximately 1 × 2.25 × 2.5 inches and will easily plug into the DB25 socket on a synchronized data communications equipment (DCE) communication device.

DIFFERENTIAL VOLTAGE-TO-CURRENT CONVERTER

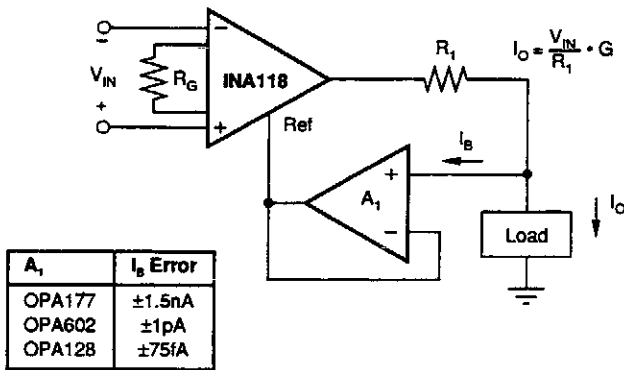

DESIRED GAIN	R_c (Ω)	NEAREST 1% R_c (Ω)
1	NC	NC
2	50.00k	49.9k
5	12.50k	12.4k
10	5.556k	5.62k
20	2.632k	2.61k
50	1.02k	1.02k
100	505.1	511
200	251.3	249
500	100.2	100
1000	50.05	49.9
2000	25.01	24.9
5000	10.00	10
10000	5.001	4.99

BURR-BROWN

Fig. 20-10

DIRECT-CONVERSION 7-MHz RECEIVER

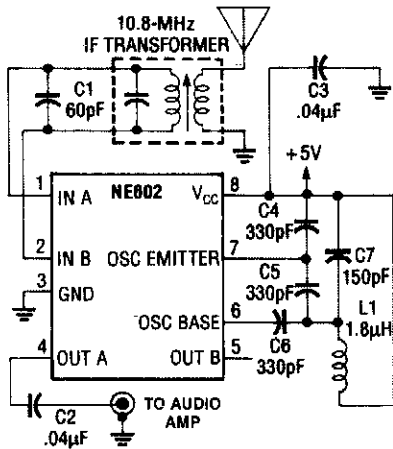

RADIO-ELECTRONICS

Fig. 20-11

An NE602 is used to mix signals in the 7-MHz range with an LO and to produce audio output.

LOW-FREQUENCY CONVERTER

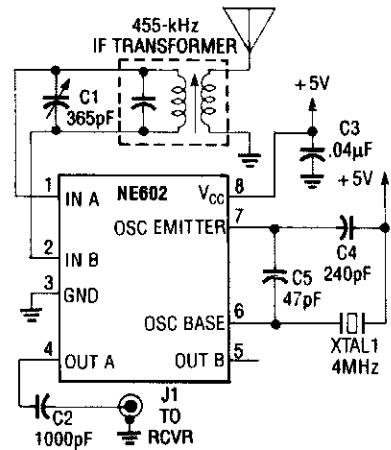

RADIO-ELECTRONICS

Fig. 20-12

This converter circuit translates the 350- to 500-kHz range to 4.35 to 4.50 MHz, enabling the frequency range to be received on a conventional shortwave receiver.

PROGRAMMABLE CURRENT-TO-VOLTAGE CONVERTER

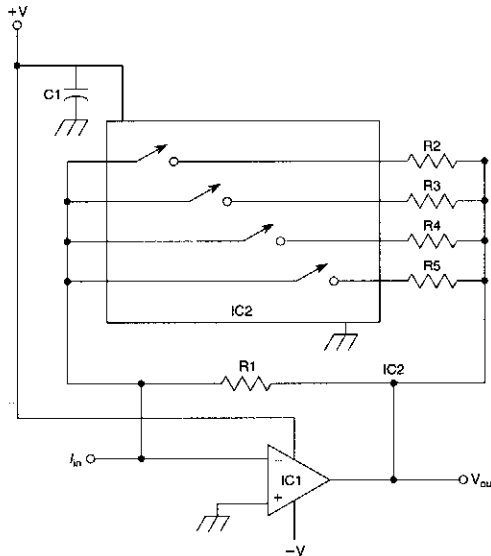

Programmable current-to-voltage converter permits you to electrically select from 16 resistor values using bilateral switches.

- IC1 741 op amp (or similar)
- IC2 CD4066 quad bilateral switch
- C1 0.1- μ F capacitor
- R1 10-k Ω , 1/4-W 5% resistor
- R2 4.7-k Ω , 1/4-W 5% resistor
- R3 2.2-k Ω , 1/4-W 5% resistor
- R4 1.2-k Ω , 1/4-W 5% resistor
- R5 100- Ω , 1/4-W 5% resistor

McGRAW-HILL

Fig. 20-13

CURRENT-TO-VOLTAGE CONVERTER WITH BOOST TRANSISTOR

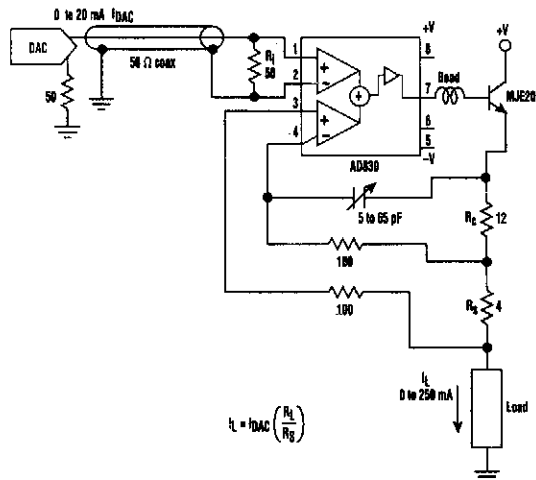

ELECTRONIC DESIGN

Fig. 20-14

A transistor such as the MJE200 can be added to an Analog Devices AD830 to produce this current to voltage converter. Loads to 250 mA can be driven. The 5- to 65-pF trimmer is for compensation.

CURRENT-TO-VOLTAGE CONVERTER FOR GROUNDED LOADS

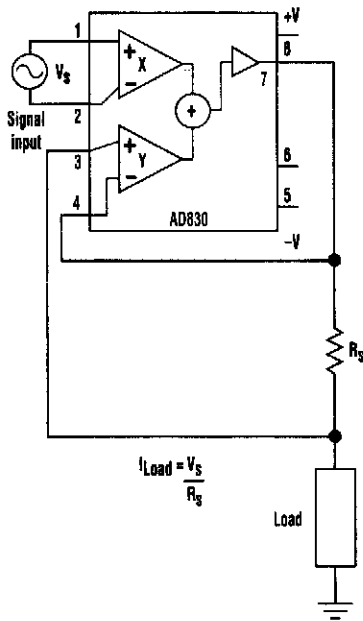

This circuit uses an Analog Devices AD830 video difference amplifier. The circuit consists of two differential inputs. Unlike a conventional op amp, the AD830's output is nulled when the sum of the differences of the two inputs is zero.

The AD830's stated unity-gain bandwidth is 60 MHz, and the device is capable of driving up to ± 30 mA directly. The differential input voltage is limited to ± 2 V, while the maximum power supply is ± 15 V.

If more output current is desired, the AD830 can drive a bipolar transistor (such as an MJE200) directly. This will produce a one-sided output.

A ferrite bead can be placed on the base to prevent oscillation under some conditions. Compensation can be added by splitting R_s and adding a variable capacitor. A resistor can be positioned at the input to match the amplifier's input to a transmission line.

ELECTRONIC DESIGN

Fig. 20-15

OUTPUT-TO-CURRENT CONVERTER

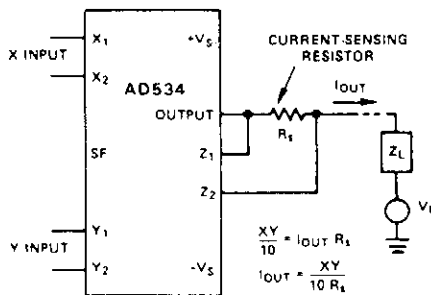

Occasionally, it is preferable to generate a current, rather than a voltage, output into the load. The availability of differential inputs allows this to be accomplished in any of the four basic modes.

If the output is to be integrated, Z_L can be simple high-quality capacitor, unloaded by an op amp connected as a high-impedance follower. Note that, if desired, one side of a rest switch can be grounded.

The compliance constraint for this configuration, where V_L is an arbitrary common-mode potential, is:

$$|V_L + I_{OUT} (Z_L + R_s)| \leq 12 \text{ V}$$

ANALOG DEVICES

Fig. 20-16

21

Crystal Oscillator Circuits

The sources of the following circuits are contained in the Sources section, which begins on page 707. The figure number in the box of each circuit correlates to the entry in the Sources section.

- FET Quartz Crystal Oscillator
- Crystal Oscillator I
- FET VXO Circuit
- UJT 100-kHz Calibration Oscillator
- Crystal Oscillator with FM Capability
- Crystal Oscillator II
- dc-Switched Crystal Oscillator
- Crystal Oscillator with Adjustable Frequency
- Frequency Doubler and Crystal Oscillator
- Crystal Oscillator III
- Colpitts Oscillator

FET QUARTZ CRYSTAL OSCILLATOR

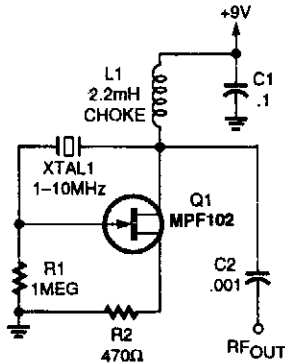

POPULAR ELECTRONICS

Fig. 21-1

This oscillator uses an MPF102 JFET as an active element.

CRYSTAL OSCILLATOR I

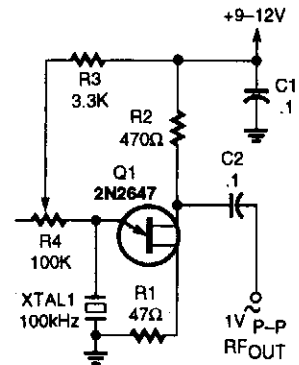

POPULAR ELECTRONICS

Fig. 21-2

In this circuit, series-resonant crystal XTAL1 is used as a frequency-determining element. XTAL1 is between 0.1 to 10 MHz.

FET VXO CIRCUIT

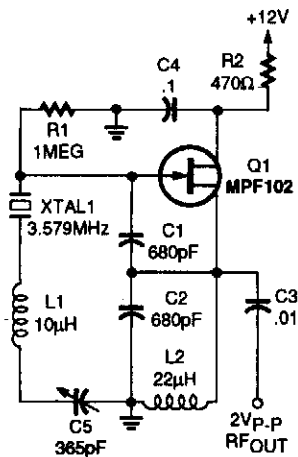

POPULAR ELECTRONICS

Fig. 21-3

An MPF 102 is used in a Colpitts-type oscillator in order to pull the crystal frequency slightly.

UJT 100-kHz CALIBRATION OSCILLATOR

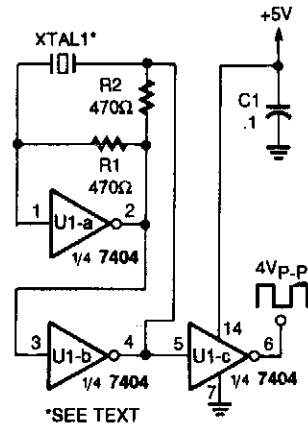

POPULAR ELECTRONICS

Fig. 21-4

This unusual 100-kHz oscillator (whose frequency is determined by XTAL1) can be used as a marker generator to calibrate the analog dial of a communication receiver, or its output can be fed to a divider counter to produce a stable lower-frequency output for use as a clock-signal generator.

CRYSTAL OSCILLATOR WITH FM CAPABILITY

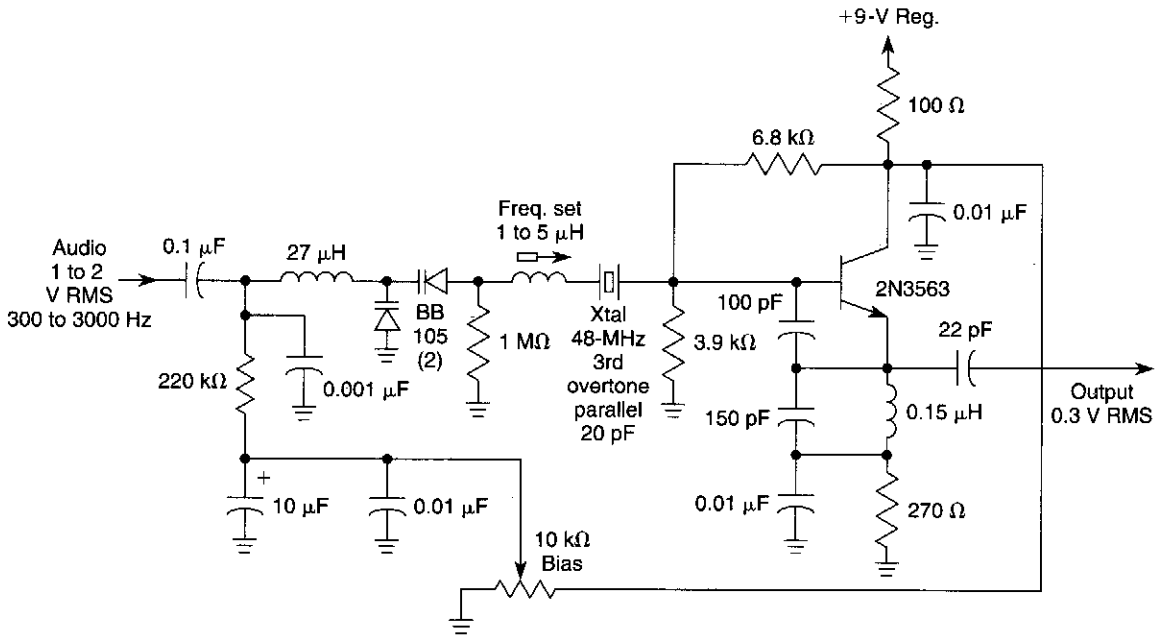

WILLIAM SHEETS

Fig. 21-5

This crystal oscillator produces a good FM signal that can be tripled to 146 MHz and produces a clean 5-kHz deviation signal for FM voice. The bias control is adjusted for cleanest audio while the 1- to 5- μH coil is adjusted to set the oscillator frequency to the exact setting required.

CRYSTAL OSCILLATOR II

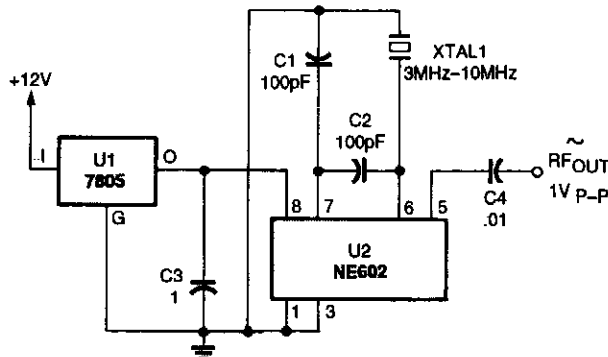

POPULAR ELECTRONICS

Fig. 21-6

An NE602 can be used as a crystal oscillator.

dc-SWITCHED CRYSTAL OSCILLATOR

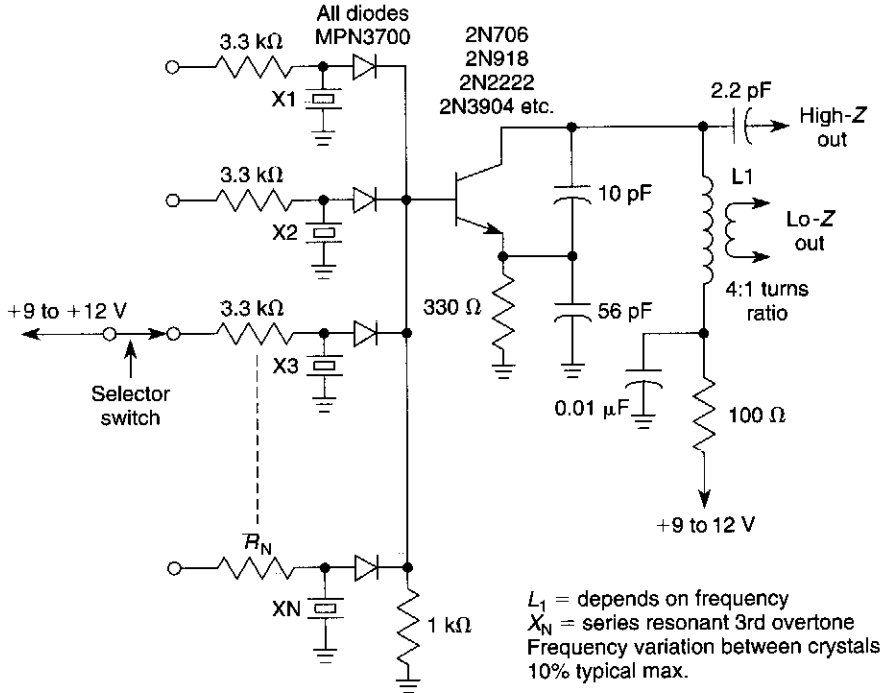

WILLIAM SHEETS

Fig. 21-7

This circuit is useful where several different crystal frequencies must be switched using a dc source. The values shown are typical for 40- to 60-MHz third-overtone crystals. Limitation on number of crystals depends on PIN diode capacitance and layout factors, but up to 5 or 10 crystals is possible.

CRYSTAL OSCILLATOR WITH ADJUSTABLE FREQUENCY

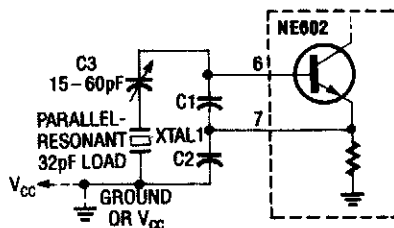

RADIO-ELECTRONICS

Fig. 21-8

In this crystal oscillator circuit, C3 adjusts the frequency of the oscillator for exact netting. The crystal is a fundamental type. $C_1 = 100$ pF and $C_2 = 1000$ pF are typical.

FREQUENCY DOUBLER AND CRYSTAL OSCILLATOR

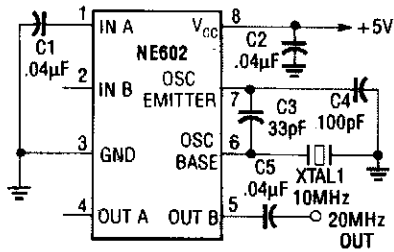

RADIO-ELECTRONICS

Fig. 21-9

This frequency doubler produces a sine wave at twice the frequency of XTAL1. Notice that the output is taken only from OUT B (pin 5), while OUT A (pin 4) is left open.

CRYSTAL OSCILLATOR III

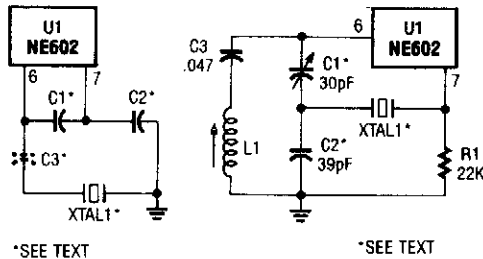

*SEE TEXT

*SEE TEXT

RADIO CRAFT

Fig. 21-10

These circuits are for use with a crystal-controlled LO using the NE602. C1, C2, and C3 are for crystals in the 5-MHz region and are approximately chosen from

$$C_1 = \frac{100}{\sqrt{f_{\text{MHz}}}} \text{ pF}, \quad C_2 = \frac{1000}{\sqrt{f_{\text{MHz}}}} \text{ pF}$$

C3 is for fine tuning the crystal frequency and will be 20 to 50 pF typically.

COLPITTS OSCILLATOR

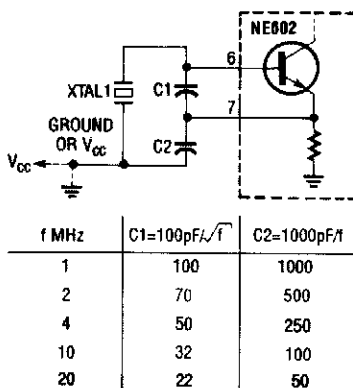

Here: $L_1 = 7 \mu\text{H}/f$, $C_1 \approx C_2 \approx C_3 \approx 2400 \text{ pF}/f$, where f is in MHz. In this circuit, the oscillator is free-running.

RADIO-ELECTRONICS

Fig. 21-11

22

Current Source and Sink Circuits

The sources of the following circuits are contained in the Sources section, which begins on page 707. The figure number in the box of each circuit correlates to the entry in the Sources section.

Current Generator
Voltage-Controlled Current Source
Voltage-Controlled Current Sink
Multiple Fixed Current Source

CURRENT GENERATOR

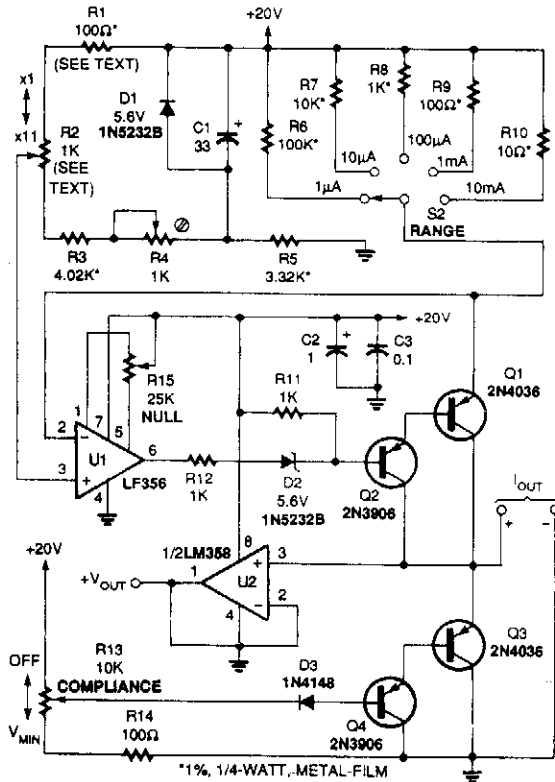

This circuit is useful for supplying constant current to test semiconductors. V_{OUT} from U2 reads the voltage across the load connected to I_{OUT} . R13 adjusts the supply compliance from 1 to about 18 V.

POPULAR ELECTRONICS

Fig. 22-1

VOLTAGE-CONTROLLED CURRENT SOURCE

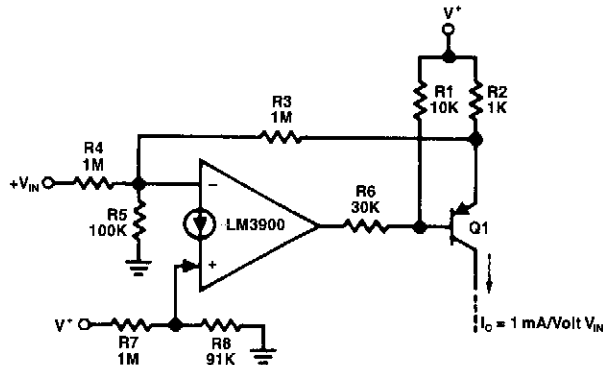

NATIONAL SEMICONDUCTOR

Fig. 22-2

A voltage-variable current source is shown in the figure. The transconductance is $-(1/R_2)$ as the voltage gain from the input terminal to the emitter of Q1 is -1 . For $V_{in} = 0$ Vdc, the output current is essentially 0 mA dc. Resistors R1 and R6 guarantee that the amplifier can turn OFF transistor Q1.

VOLTAGE-CONTROLLED CURRENT SINK

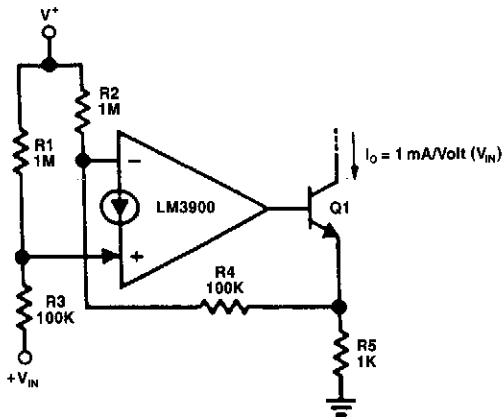

A voltage-variable current sink is shown in the figure. The output current is 1 mA per volt of V_{in} (as $R_5 = 1\text{ k}\Omega$ and the gain is +1). This circuit provides approximately 0 mA output current for $V_{in} = 0\text{ V DCL}$.

NATIONAL SEMICONDUCTOR

Fig. 22-3

MULTIPLE FIXED CURRENT SOURCE

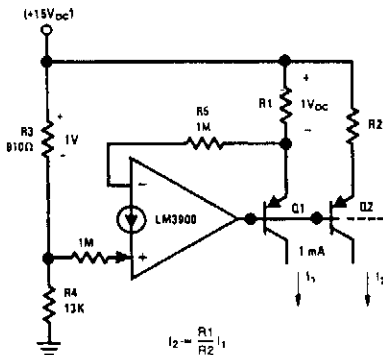

A multiple fixed current source is provided by the circuit. A reference voltage (1 Vdc) is established across resistor R_3 by the resistive divider (R_3 and R_4). Negative feedback is used to cause the voltage drop across R_1 to also be 1 Vdc. This controls the emitter current of transistor Q_1 and if we neglect the small current diverted into the (-) input via the 1-M Ω input resistor (13.5 μA) and the base current of Q_1 and Q_2 (an additional 2% loss if the β of these transistors is 100), essentially this same current is available out of the collector of Q_1 .

Larger input resistors can be used to reduce current loss and a Darlington connection can be used to reduce errors caused by the β of Q_1 .

The resistor, R_2 , can be used to scale the collector current of Q_2 either above or below the 1-mA reference value.

NATIONAL SEMICONDUCTOR

Fig. 22-4

23

dc-to-dc Converter Circuits

The sources of the following circuits are contained in the Sources section, which begins on page 707. The figure number in the box of each circuit correlates to the entry in the Sources section.

Isolated dc-to-dc Converter

dc-to-dc Converter I

Ultra Low-Power dc-to-dc Converter for Personal Communications Products

Negative Step-Up dc-to-dc Converter

dc-to-dc Converter II

ISOLATED dc-to-dc CONVERTER

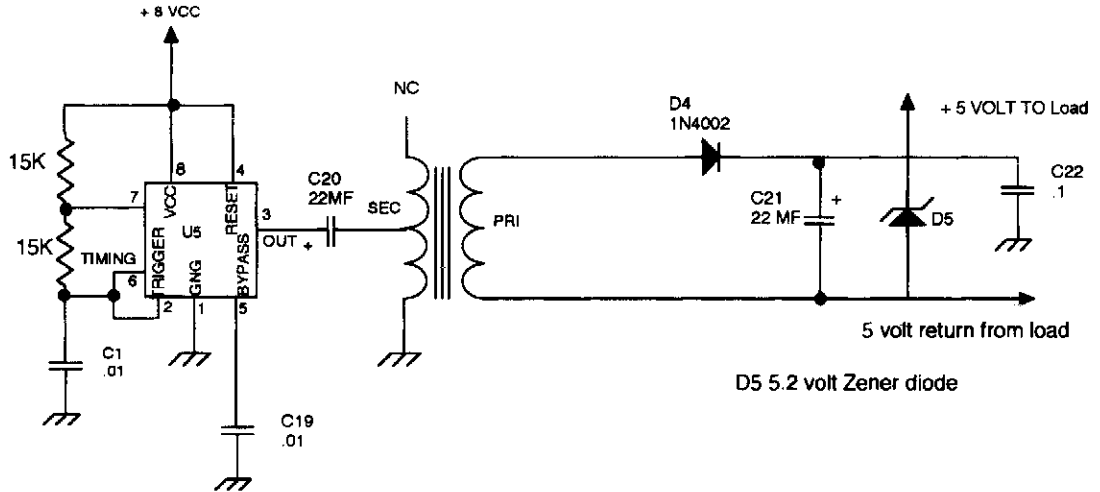

73 AMATEUR RADIO TODAY

Fig. 23-1

A NE555 timer is used to drive a small transformer to change the 5- to 7-Vp-p output of the NE555 to a suitable value to drive a rectifier/Zener combination. This method is useful where a small isolated power source is needed.

dc-to-dc CONVERTER

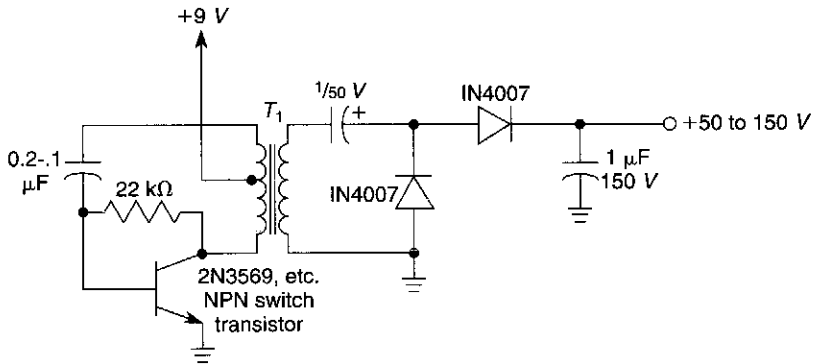

WILLIAM SHEETS

Fig. 23-2

This converter should be useful where a few milliamperes of dc at a higher voltage than available supplies can deliver is needed. T1 is typically a 1 kΩ CT:10-kΩ transistor audio transformer. Depending on T1, about 50 to 150 Vdc can be obtained at a few milliamperes.

ULTRA LOW-POWER dc-to-dc CONVERTER FOR PERSONAL COMMUNICATIONS PRODUCTS

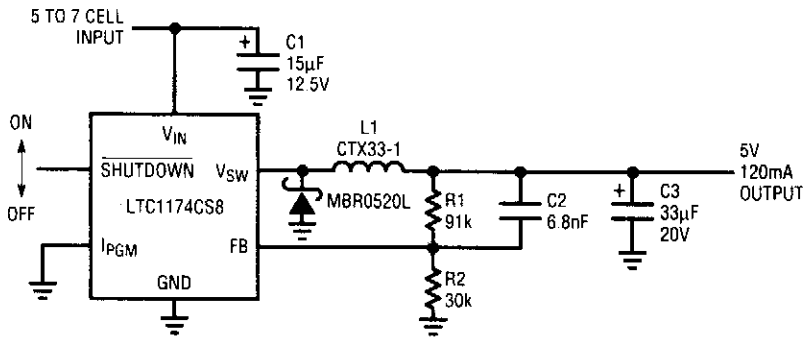

C1: PANASONIC SP SERIES (201) 348-4630
 C2: AVX TAJ SERIES (803) 956-0690
 L1: COILTRONICS OCTAPAK (407) 241-7876

LINEAR TECHNOLOGY

Fig. 23-3

The LTC1174 step-down converter is designed specifically to eliminate noise at audio frequencies while maintaining high efficiency at low output currents. This circuit shows a 5-V, 120-mA output derived from 5 to 7 NiCad or NiMH cells. Small input and output capacitors that are capable of handling the necessary ripple currents help conserve space. In applications where shutdown is desired, this feature is available (otherwise short this pin to V_{in}).

The LTC1174's internal switch, connected between V_{in} and V_{sw} , is current controlled at a peak of approximately 340 mA. Low peak switch current is one of the key features that allows the LTC1174 to minimize system noise compared to other chips that carry significantly higher peak currents, easing shielding and filtering requirements, and decreasing component stresses. Output current of up to 450 mA is possible with this device by connecting the 1 pgm pin to V_{in} . This increases the peak current to 600 mA, allowing for a high average output current.

NEGATIVE STEP-UP dc-to-dc CONVERTER

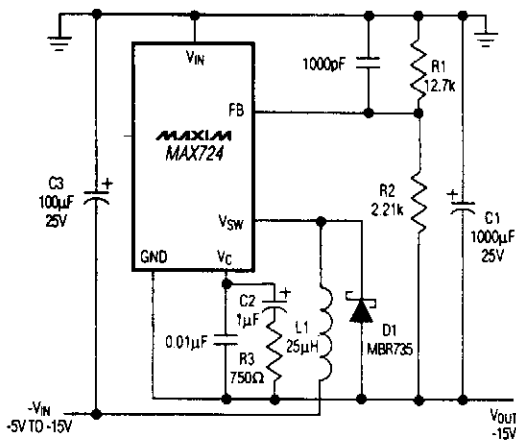

A Maxim MAX724 is used in a step-up switching converter to provide -15-V output from a -5- to -15-V input.

MAXIM

Fig. 23-4

dc-to-dc CONVERTER II

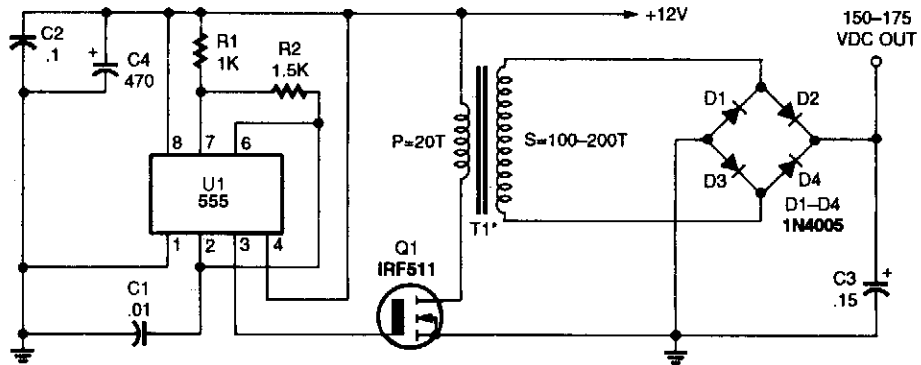

POPULAR ELECTRONICS

Fig. 23-5

In this dc-to-dc converter, the 555 is used to produce a rising and collapsing field in T1's primary, generating a high voltage in T1's secondary winding. That voltage is then full-wave, bridge rectified by D1 through D4, and filtered by C3. T1 is an Amidon Associates EA-775-375E core and nylon bobbin, with #26 wire for the primary and #28 or #30 for the secondary. About 5 W of power is available.

24

Decoder Circuits

The sources of the following circuits are contained in the Sources section, which begins on page 707. The figure number in the box of each circuit correlates to the entry in the Sources section.

DTMF Decoder
FM Stereo Decoder
Typical NE567 Tone Decoder Circuit
Video Line Decoder I
Video Line Decoder II

DTMF DECODER

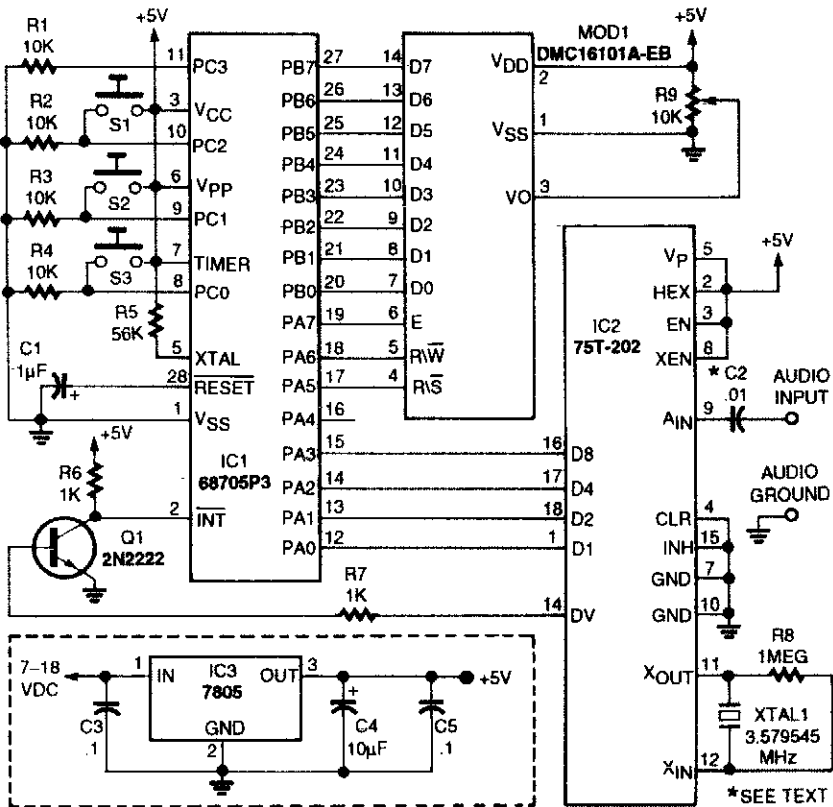

ELECTRONICS NOW

Fig. 24-1

This DTMF decoder uses a Motorola 68705P3 microcontroller and a 75T202 DTMF receiver (Silicon Systems, Inc.). An LCD module is used for the display (MOD1). Switch S1 is used to scroll the display, S2 clears the display, and S3 clears the memory.

FM STEREO DECODER

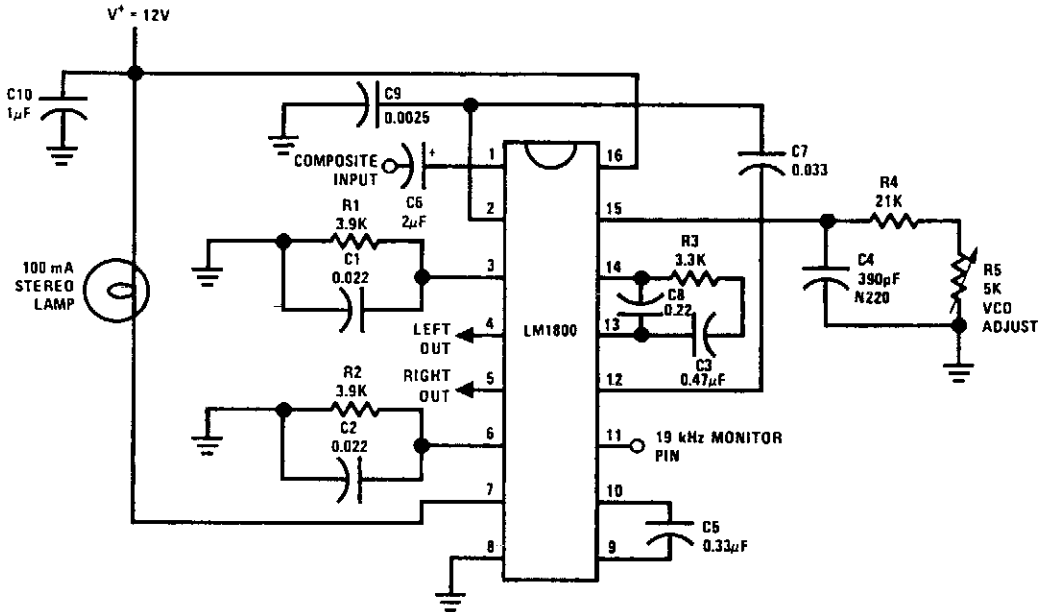

NATIONAL SEMICONDUCTOR

Fig. 24-2

Using an LM1800, this circuit takes composite baseband MPX input and recovers LTR audio channels. The VCO is set for 19 kHz (or 15.7 kHz for TV applications) or as needed.

TYPICAL NE567 TONE DECODER CIRCUIT

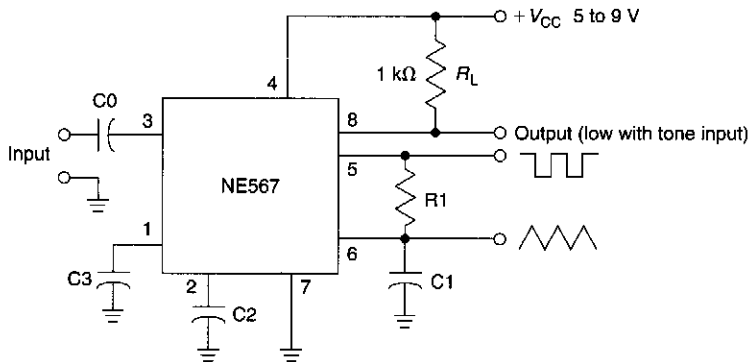

$$f_0 = 1/1.1R_1C_1 \quad BW = 1070\sqrt{V_1/f_0C_2} \quad V_1 \leq 200 \text{ mV RMS}$$

$$X_{CO} \approx < 2 \text{ k}\Omega @ f_0 \quad f_0 \text{ Hz} \quad C_3 \approx 2C_2$$

$$C_2 \mu\text{F} \quad V_1 \text{ V}$$

WILLIAM SHEETS

Fig. 24-3

This circuit illustrates use of NE567 as a tone decoder.

VIDEO LINE DECODER I

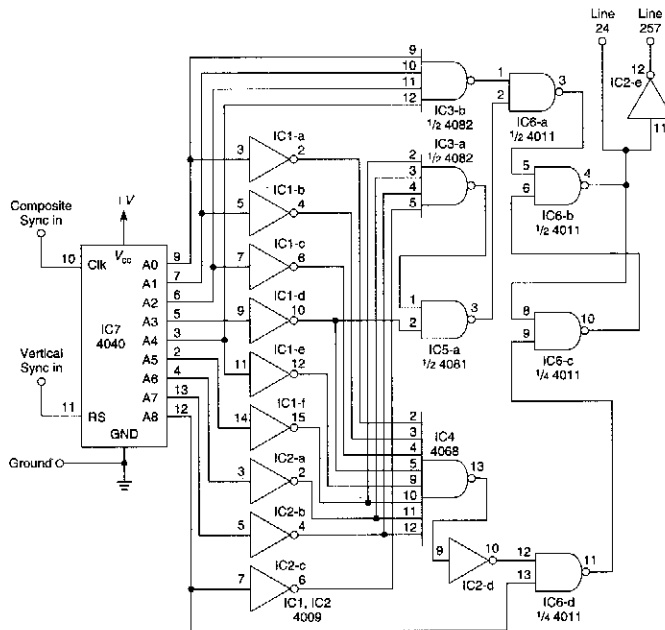

ELECTRONICS NOW

Fig. 24-4

This line decoder uses only one pin for the line indicator.

VIDEO LINE DECODER II

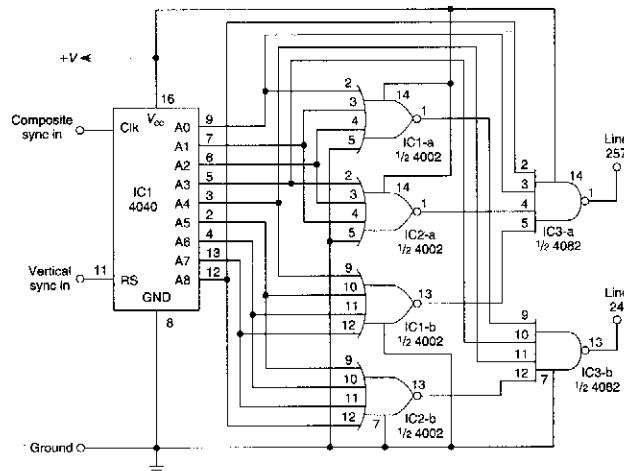

ELECTRONICS NOW

Fig. 24-5

This circuit will produce pulses useful for gating lines 24 and 257 of a video signal, but by changing the decoding logic, other lines can be decoded.

25

Delay Circuits

The sources of the following circuits are contained in the Sources section, which begins on page 707. The figure number in the box of each circuit correlates to the entry in the Sources section.

Time-Delay Generator
Simple Time Delay Circuit

TIME-DELAY GENERATOR

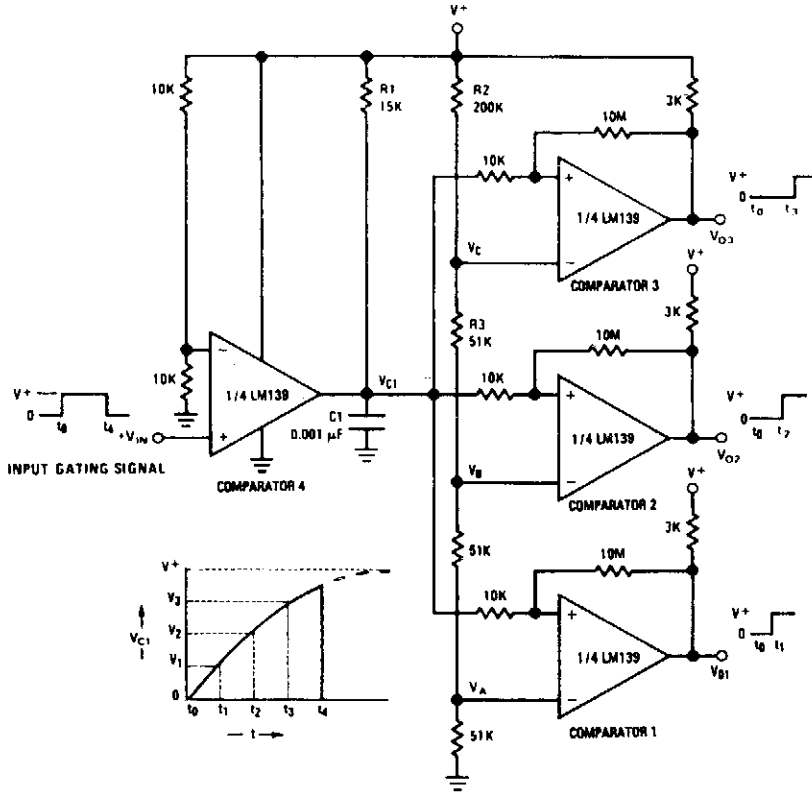

NATIONAL SEMICONDUCTOR

Fig. 25-1

This circuit uses a charging capacitor and three comparators to read the voltage across it.

SIMPLE TIME DELAY CIRCUIT

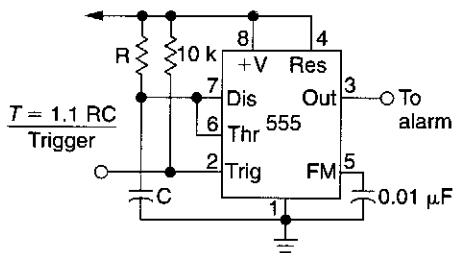

ELECTRONICS NOW

Fig. 25-2

Rotating the potentiometer wiper will change the time delay from the 555 IC.

26

Detector Circuits

The sources of the following circuits are contained in the Sources section, which begins on page 707. The figure number in the box of each circuit correlates to the entry in the Sources section.

High-Speed Peak Detector with Hold and Reset Controls
Lock Detector
Linearized RF Detector
Glitch Detector
VCR Video Detector Controller
Grid-Leak Detector
Negative Peak Detector
Double-Ended Limit Detector
Positive Peak Detector
LM556 Timer Frequency Detector
Single-Comparator Window Detector
15-kHz Tone Detector
Crystal Radio Detector
Switch Closure Circuit
Air Flow Detector
Low Drift Peak Detector
Negative Peak Detector
Positive Peak Detector
455-kHz AM Detector
ac Noise Detector

HIGH-SPEED PEAK DETECTOR WITH HOLD AND RESET CONTROLS

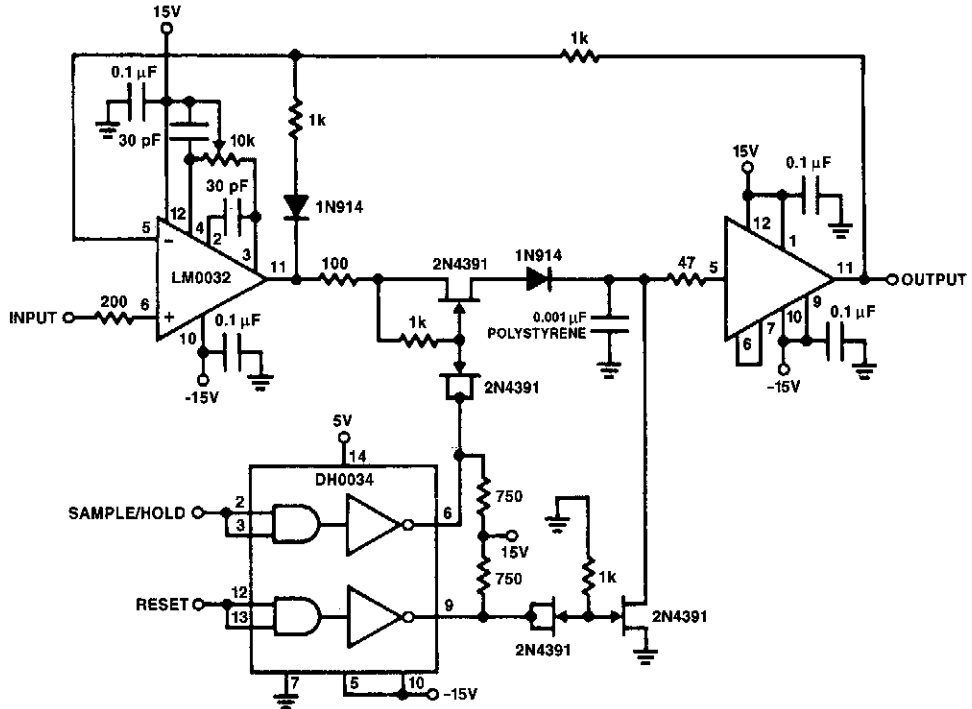

NATIONAL SEMICONDUCTOR

Fig. 26-1

The LH0033 and LH0063 are useful in high-speed sample-and-hold or peak detector circuits because of their very high speed and low-bias-current FET input stages. The high-speed peak detector circuit shown could be changed to a sample-and-hold circuit simply by removing the detector diode and reset circuitry. For best accuracy, the circuit can be trimmed with the 10-kΩ offset adjustment pot shown. The circuit has a typical acquisition time of 900 ns, to 0.1% of the final value for the 10-V input step signal, and a droop rate of 100 μV/ms. Even faster acquisition time can be achieved by reducing the hold capacitor value.

LOCK DETECTOR

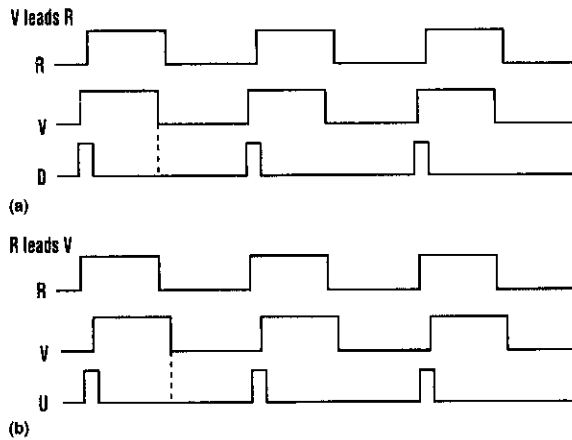
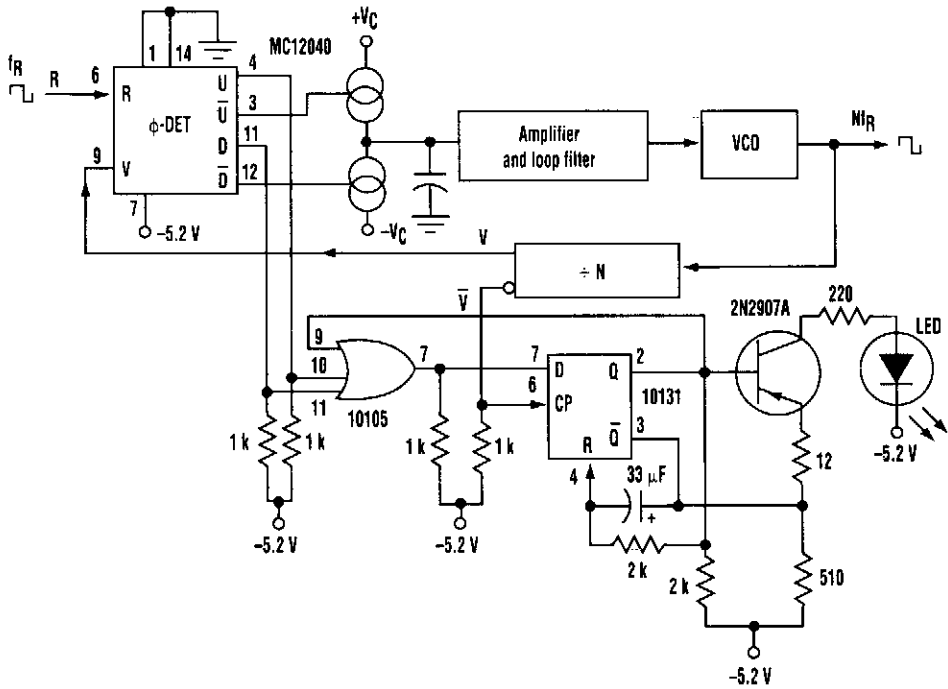

LOCK DETECTOR (Cont.)

This PLL lock indicator not only can detect a “locked” or “off-of-lock” condition, but also even if a single pulse or transition has been missed.

When being sampled by the flip-flop, if the V signal leads the input reference signal R and the rising edge of R is lost, the D signal will remain high throughout the interval, allowing the flip-flop to be clocked high (Fig. 26-2A). If the R signal leads the V signal when the transition is missed, the rising edge of the V signal will trigger the D signal of the phase detector, causing the LED to blink (Fig. 26-2B).

A “lock” detector often is used with a phase-locked loop (PLL) or synthesizer to indicate when the loop is phase-locked with an input signal. This circuit can be helpful, but single cycle skips usually will go undetected because of the presence of the low-pass filter.

LINEARIZED RF DETECTOR

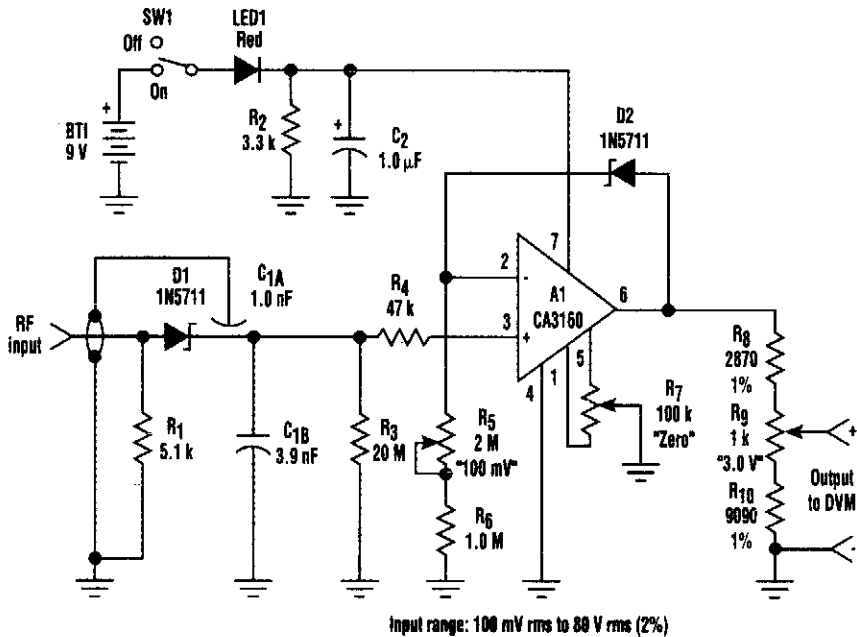

The circuit produces an extremely linear dc output for RF inputs between 80 mV rms and 4.0 mV rms. For inputs below 50 V rms, the dc output quickly drops to 0 V.

GLITCH DETECTOR

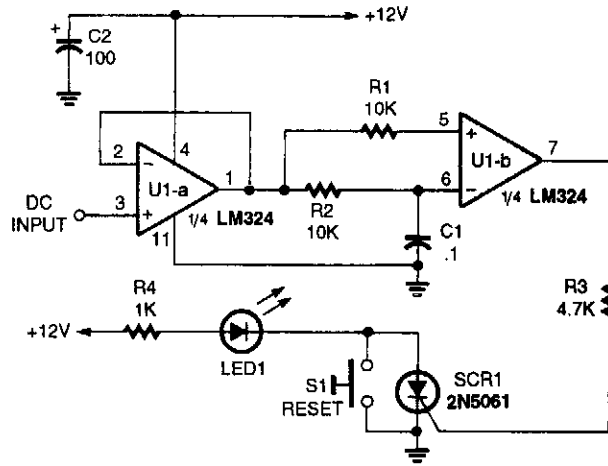

POPULAR ELECTRONICS

Fig. 26-4

In the circuit, two op amps (half of an LM324 quad op amp) and an SCR are direct coupled in a dc-voltage monitoring circuit. Op-amp U1-a is configured as a voltage follower, which feeds the bridged inputs of the second op amp, U1-b. A resistor/capacitor combination (R2/C1) connected to the negative input of U1-b forms an RC time-delay circuit. As long as there is no change in the dc-voltage level at either of U1-b's inputs, its output is near zero. If a voltage glitch occurs, the RC timing circuit will delay the voltage change at the op amp's inverting input, causing its output to go high, triggering SCR1 and causing LED1 to light. The circuit's sensitivity allows it to detect voltage changes in the millivolt range. Pressing S1 diverts the SCR's holding current to ground, causing it to turn off and reset the circuit.

VCR VIDEO DETECTOR CONTROLLER

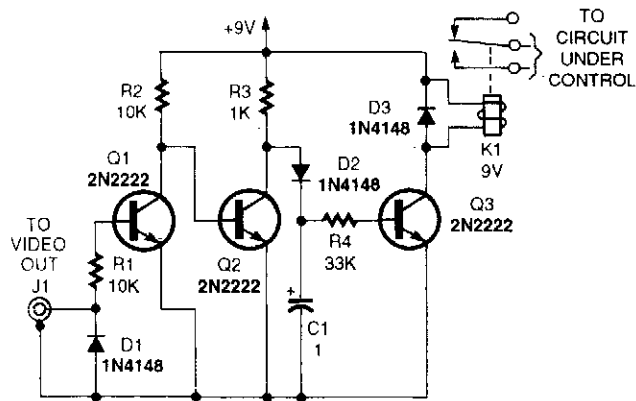

POPULAR ELECTRONICS

Fig. 26-5

This circuit uses the video output from a VCR or camera to control a relay. Video turns on Q1, cutting off Q2, allowing Q3 to be forward biased, activating relay K1. You can use the timer in your VCR and this unit to generate long time delays as well.

GRID-LEAK DETECTOR

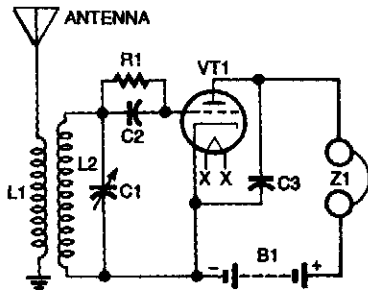

ELECTRONICS NOW

Fig. 26-6

Tuned-circuit receiver with grid-leak detection.

NEGATIVE PEAK DETECTOR

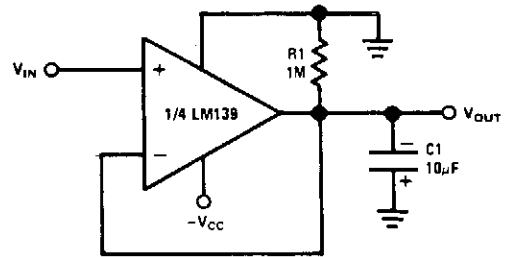

NATIONAL SEMICONDUCTOR

Fig. 26-7

DOUBLE-ENDED LIMIT DETECTOR

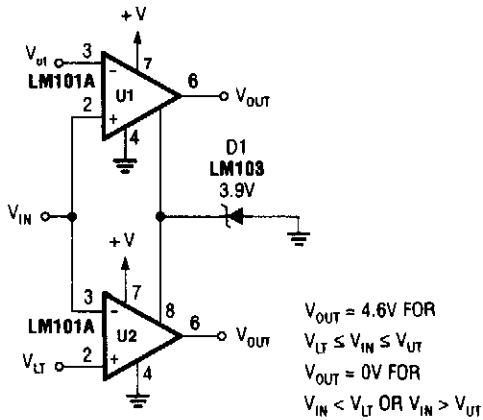

POPULAR ELECTRONICS

Fig. 26-8

POSITIVE PEAK DETECTOR

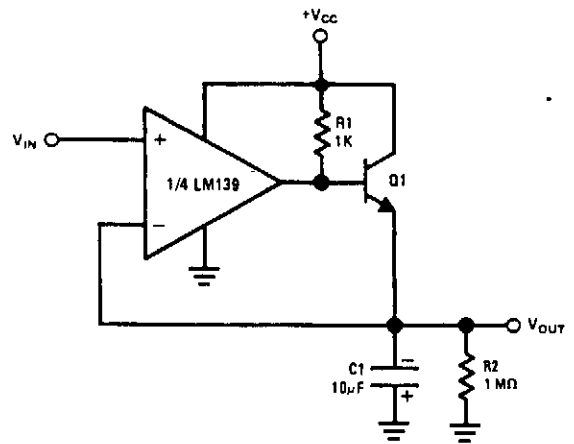

NATIONAL SEMICONDUCTOR

Fig. 26-9

LM556 FREQUENCY DETECTOR

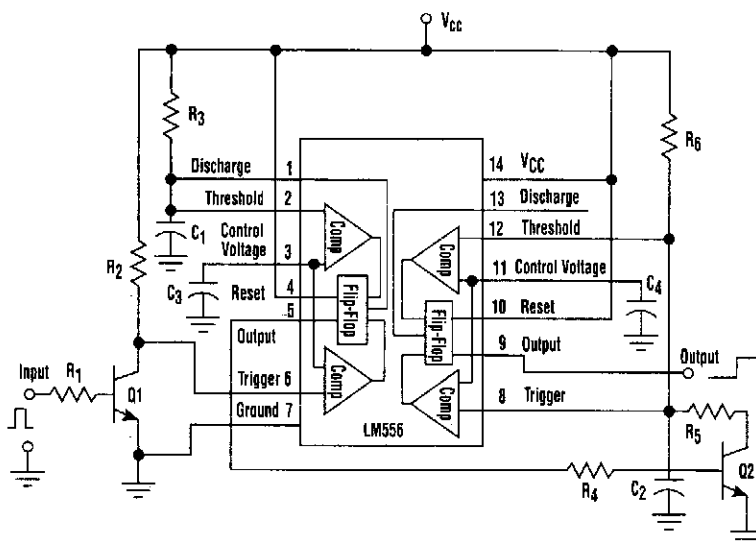

ELECTRONIC DESIGN

Fig. 26-10

The circuit (see the figure), is built around an LM556 dual-timer IC. The 556's first timer is wired as a one-shot and is used to stretch the incoming pulses into fixed-length pulses. The second timer, which is similar to an astable multivibrator (pin 13 remains disconnected), functions as follows:

The one-shot's fixed-length pulses, which are output on pin 5, turn on Q1 and discharge C2 through R5. If the frequency of the pulses is high enough, the voltage on C2 will fall below $\frac{1}{3} V_{CC}$ and the second timer's output, pin 9, will go to a logic 1. Conversely, if the frequency is low enough or is zero, the voltage on C2 will charge through R6 to a level above $\frac{2}{3} V_{CC}$, and the pin 9 output will go to a logic "0."

The idea is to keep the upper and lower peak voltage on C2 below $\frac{2}{3} V_{CC}$ and $\frac{1}{3} V_{CC}$, respectively for a logic 1, and above $\frac{2}{3} V_{CC}$ and $\frac{1}{3} V_{CC}$, respectively, for a logic 0.

To find the one-shot values, R3 and C1, select a pulse width ($1.1 \times R_3 \times C_1$) that's greater than the largest input pulse width and less than twice the inverse of the highest input frequency. To find R5, R6, and C2, first determine the duty cycle (t_{on}/t_{off}) of the input signal. Next, choose a standard value for C2 and calculate R6:

$$R_6 = \frac{[(t_{off} \times 0.61)^2 + t_{off}]}{C_2}$$

Also, $R_5 = R_6 (t_{on}/t_{off})$. A tweak of resistors R5 and R6 might be needed to get the preferred response. Input signals with low duty cycles work the best. Finally, notice that capacitors C3 and C4 can be any value between 0.01 and 0.1 μF .

SINGLE COMPARATOR WINDOW DETECTOR

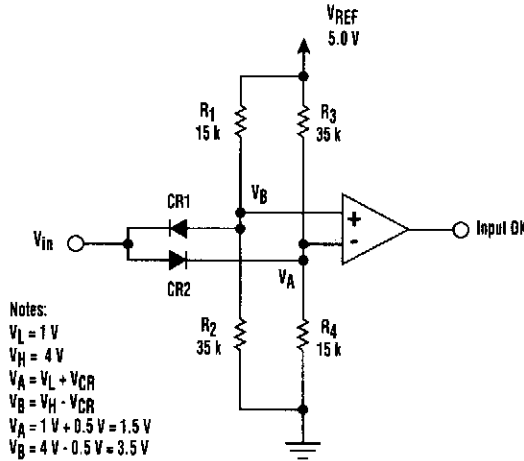

ELECTRONIC DESIGN

Fig. 26-11

Simply by adding two steering diodes, a window detector can be built using only a single comparator. The detector performs well for windows of about 1 V or greater, but it isn't suitable where extreme precision is required because the forward drops of the diodes vary.

In the basic circuit, two resistive dividers set threshold voltage levels at both the inverting and noninverting inputs of the comparator by dividing the reference voltage. The input voltage is steered to the appropriate comparator input by diodes CR1 and CR2.

When the input voltage is within the window, neither diode conducts, and the comparator is biased for a high output. When the input goes above the window, CR2 conducts and pulls the inverting input high, causing the comparator output to go low. When the input voltage goes below the window, CR1 conducts, pulling the noninverting input low, again causing the comparator output to go low. The source resistance of V_{in} must be low compared to the equivalent parallel resistance of each divider.

15-kHz TONE DETECTOR

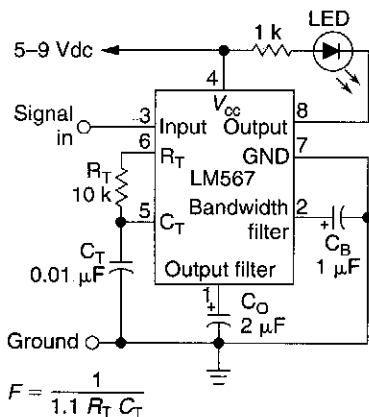

This circuit detects the presence of a 15-kHz audio signal and light the LED when it does so.

ELECTRONICS NOW!

Fig. 26-12

CRYSTAL RADIO DETECTOR

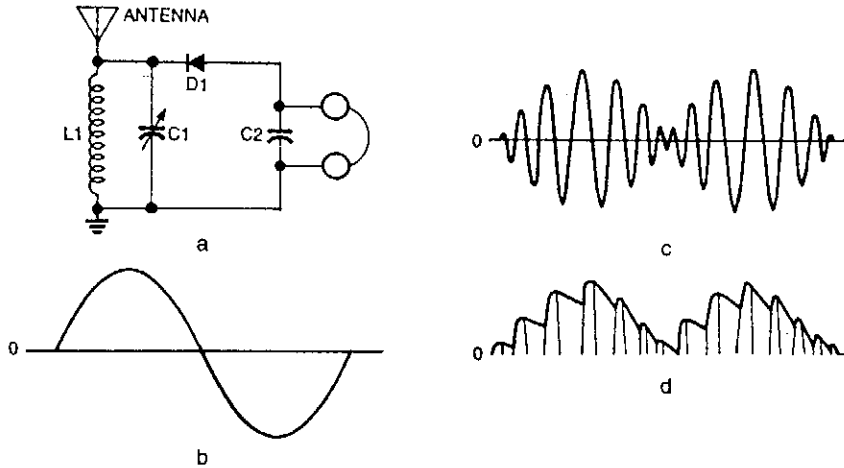

Fig. 26-13

ELECTRONICS NOW!

This is a crystal detector receiver with headphones (Fig. 26-13A), audio-frequency signal (Fig. 26-13B), modulated signal (Fig. 26-13C), and a demodulated wave (Fig. 26-13D).

SWITCH CLOSURE CIRCUIT

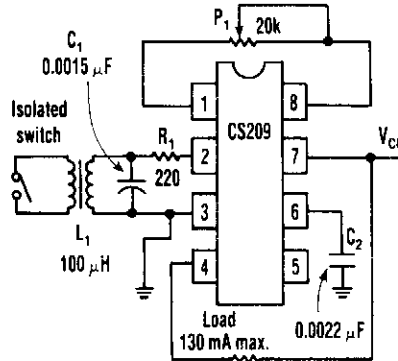
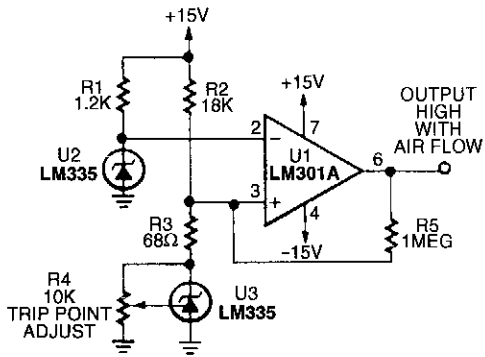

Fig. 26-14

ELECTRONIC DESIGN

A standard proximity detector circuit for the Cherry Semiconductor CS209 IC can detect an isolated switch closure by adding a few turns of wire around the circuit's inductor (Radio Shack 273-102). Moreover, the technique doesn't require any isolated power (see the figure). With the switch open, the potentiometer P_1 is adjusted until the output switches off. When the switch is closed, the Q of the circuit changes and the output turns on. Capacitor C_1 should be silvered mica, and potentiometer P_1 should be a multiturn type such as the Bourns 3006P-1-203. A 9-V supply can be used for V_{CC} .

AIR FLOW DETECTOR



*SELF HEATING IS USED TO DETECT AIR FLOW

POPULAR ELECTRONICS

Fig. 26-15

LOW DRIFT PEAK DETECTOR

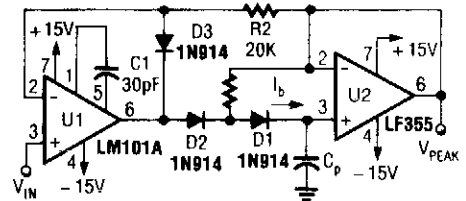

BY ADDING D1 AND D2, $V_{01} \approx 0$ DURING HOLD MODE. LEAKAGE OF D2 PROVIDED BY FEEDBACK PATH THROUGH R_f .

LEAKAGE OF CIRCUIT IS ESSENTIALLY I_b (LF155, LF156) PLUS CAPACITOR LEAKAGE OF C_p .

DIODE D3 CLAMPS V_{OUT} (A1) TO $V_{IN} - V_{D3}$ TO IMPROVE SPEED AND TO LIMIT REVERSE BIAS OF D2.

MAXIMUM INPUT FREQUENCY SHOULD BE $\ll \frac{1}{2\pi R_f C_{D2}}$ WHERE C_{D2} IS SHUNT CAPACITANCE OF D2.

POPULAR ELECTRONICS

Fig. 26-16

NEGATIVE PEAK DETECTOR

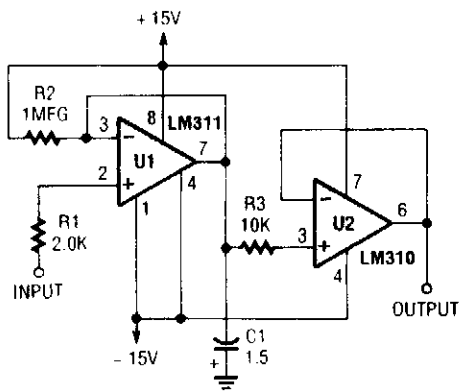

POPULAR ELECTRONICS

Fig. 26-17

POSITIVE PEAK DETECTOR

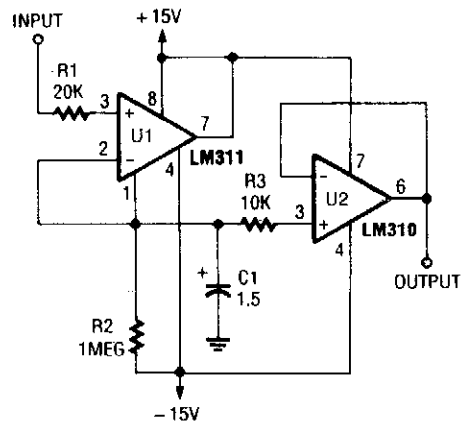

POPULAR ELECTRONICS

Fig. 26-18

455-kHz AM DETECTOR

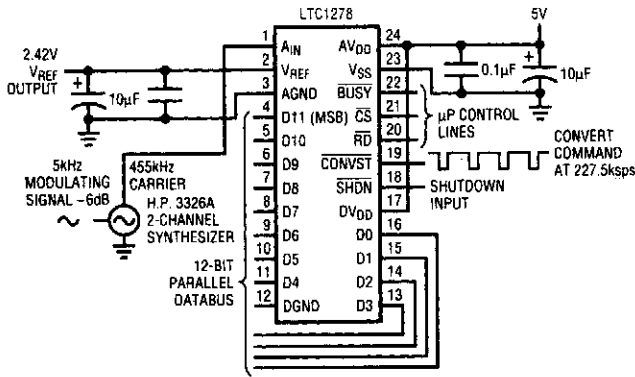

Figure A. The LTC1278 undersamples the 455-kHz carrier to recover the 5-kHz modulating signal

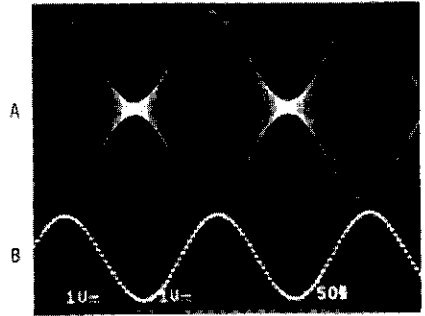

Figure B. Demodulating an IF by undersampling

LINEAR TECHNOLOGY

Fig. 26-19

The LTC1278 undersamples the 455-kHz carrier to recover the 5-kHz modulating signal. The application shown uses the LTC1278 to undersample (at 227.5 kpsps) a 455-kHz IF amplitude-modulated by a 5-kHz sine wave. Figures 26-19A and 26-19B show, respectively, the 455-kHz IF carrier and the recovered 5-kHz sine wave that results from a 12-bit DAC reconstruction.

ac NOISE DETECTOR

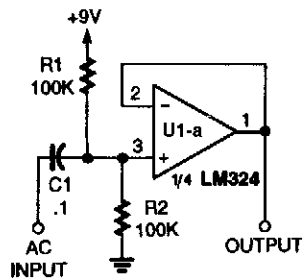

POPULAR ELECTRONICS

Fig. 26-20

This circuit can be added to the glitch detector to trigger on ac noise.

27

Differential Amplifier Circuits

The sources of the following circuits are contained in the Sources section, which begins on page 707. The figure number in the box of each circuit correlates to the entry in the Sources section.

Basic Op-Amp Differential Amplifier
Precision High Gain Differential Amp

BASIC OP-AMP DIFFERENTIAL AMPLIFIER

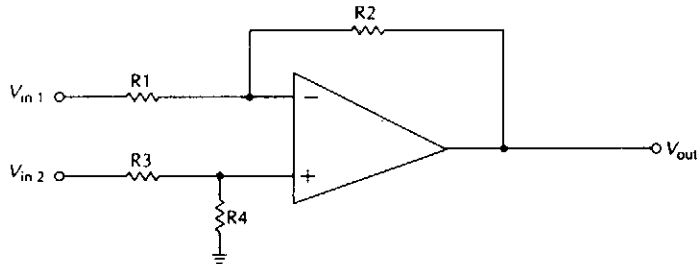

McGRAW-HILL

Fig. 27-1

In most cases, R_1 is equal to R_2 , and R_3 has the same value as R_4 . These equalities don't always have to be true, but they do significantly simplify the circuit design in most practical applications. In any case, for a true differential amplifier, the $R_3:R_1$ and $R_4:R_2$ ratios must be equal. That is:

$$\frac{R_3}{R_1} = \frac{R_4}{R_2}$$

The circuit still functions even if these ratios are not maintained, but the signals at the inverting and noninverting inputs are subjected to differing amounts of gain, which would be undesirable in most practical applications.

$$\begin{aligned} R_1 &= R_2 \\ R_3 &= R_4 \end{aligned}$$

These resistance ratios determine the gain of the amplifier:

$$G = \frac{R_3}{R_1} = \frac{R_4}{R_2}$$

Assuming that the resistance ratios are maintained, the output voltage is equal to the differences between the two input voltages, multiplied by the gain. That is,

$$V_{OUT} = G \times (V_1 - V_2)$$

PRECISION HIGH-GAIN DIFFERENTIAL AMP

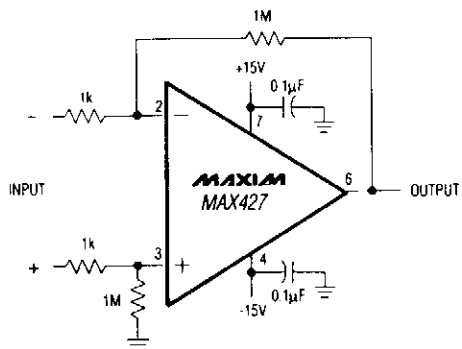

MAXIM

Fig. 27-2

This circuit has a gain of 60 dB and a gain bandwidth of 8 MHz.

28

Display Circuits

The sources of the following circuits are contained in the Sources section, which begins on page 707. The figure number in the box of each circuit correlates to the entry in the Sources section.

Multiplexed BCD Decoder-Driver Circuit
Color-Shifting LED Display
Stereo Level Display
High-Efficiency Display Contrast and Backlight Control
Bar-Graph Level Gauge
Simple Color Organ
Voice Level Meter
LCD Contrast Temperature Compensator
LED Bargraph Driver Circuit

MULTIPLEXED BCD DECODER-DRIVER CIRCUIT

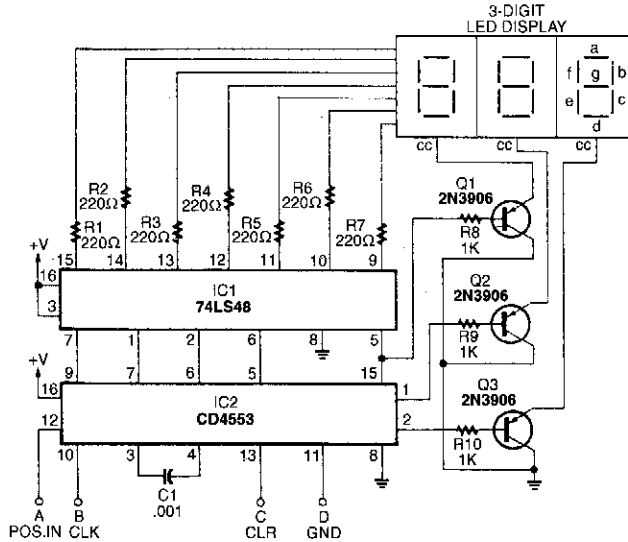

ELECTRONICS NOW

Fig. 28-1

The BCD decoder-driver circuit will interface with any standard BCD output to produce a digital display.

COLOR-SHIFTING LED DISPLAY

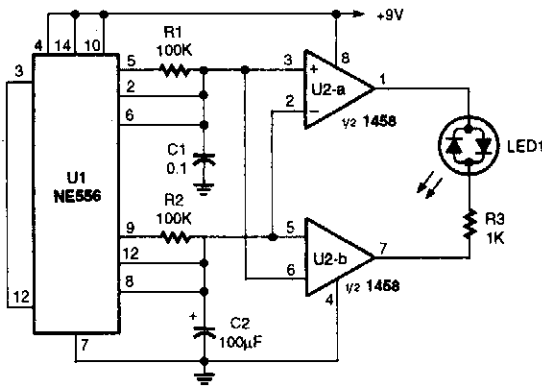

POPULAR ELECTRONICS

Fig. 28-2

This circuit is used to make a tricolor LED gradually change color from yellow to red to yellow to green, and then back to yellow, where the cycle repeats. It is very simple to make, and the theory of operation is also simple. Both of the timers in the 556 dual oscillator/timer are configured for astable operation with a 50% duty cycle. One timer is set to oscillate much faster than the other. The timing capacitor voltage of each is sent to two comparators, which apply a voltage across the tri-color LED whose polarity depends on which capacitor voltage is higher. The rapidly changing capacitor's voltage causes the red and green elements of the LED to be alternately lit, thus giving the illusion of yellow light. As the slowly rising and falling voltage from the slower trimming capacitor changes in average value, it shifts the duty cycle to favor one color or the other. That gives the transition between colors a smooth appearance.

STEREO LEVEL DISPLAY

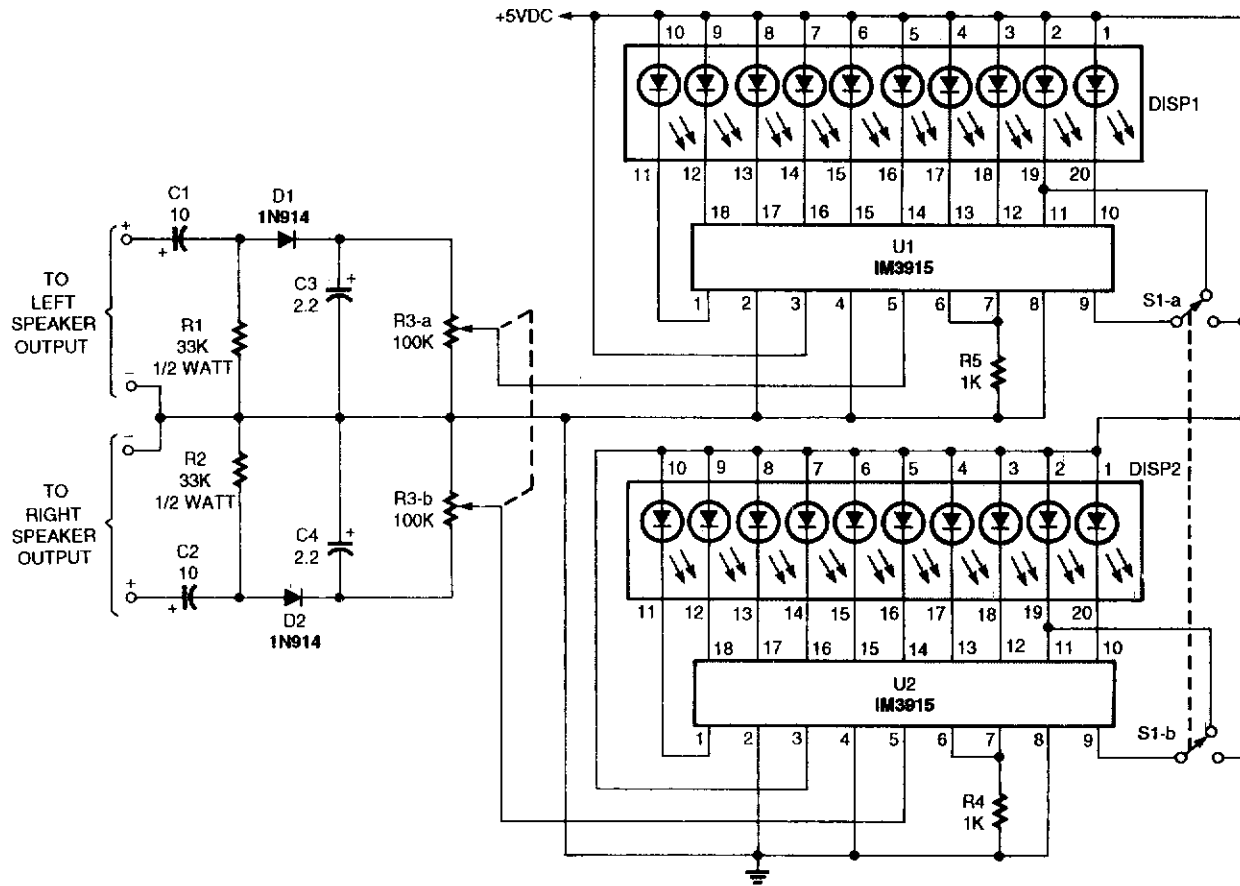

Two bar graph drivers and LEDs are used in this volume (level) indicator. R3a and R3b set the sensitivity of the circuit. The LEDs can be either bar graph units or individual LEDs can be used.

HIGH-EFFICIENCY DISPLAY CONTRAST AND BACKLIGHT CONTROL

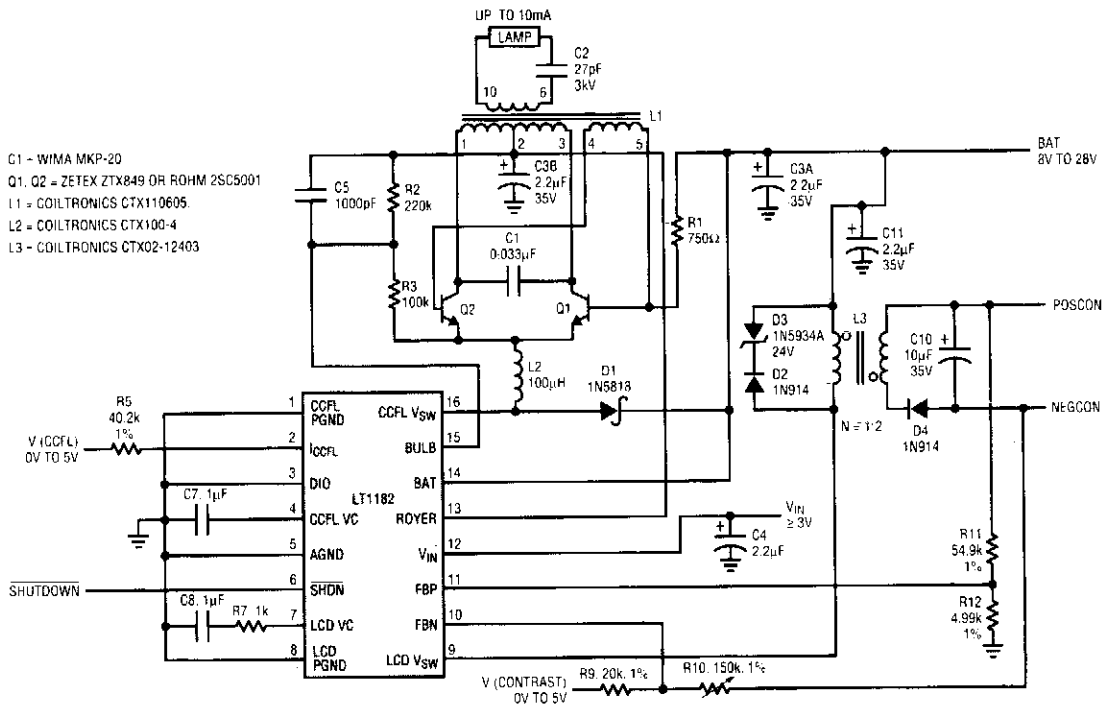

LINEAR TECHNOLOGY

Fig. 28-4

The LT1182 and LT1183 are compact high-performance solutions for powering LCD screens used in portable computers and instruments. Backlight control using a Cold Cathode Fluorescent lamp (CCFL) is accomplished with a switching regulator at efficiencies up to 90%. A second switching regulator converts the positive input to either positive or negative bias voltages used for LCD contrast control. Both regulators allow full range of adjustment using a D/A converter, PWM or potentiometer control. Grounded bulb configurations are also easily controlled with minimal parts count. The 200-kHz switching frequency minimizes the size of transformers and external components. A shutdown mode powers down both regulators and reduces supply current to just 35 μ A.

BAR-GRAPH LEVEL GAUGE

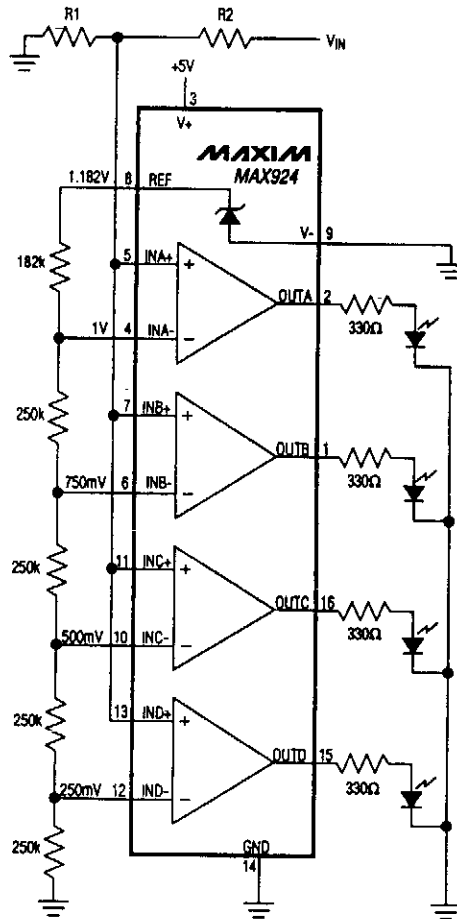

MAXIM

Fig. 28-5

A quad comparator and divider network form a 4-level comparator that drives 4 LEDs. R1 and R2 can be used to scale the basic sensitivity of 250 mV/LED to higher voltages than the basic 1 volt (for all 4 LEDs lit).

SIMPLE COLOR ORGAN

IC1	op amp
IC2, IC3, IC4	LM3909 LED flasher/oscillator
D1, D2, D3	diode (1N914, 1N4148, or similar)
D4, D5, D6	LED
T1	impedance-matching transformer (8 Ω :1 k Ω —see text)
C1, C2, C3, C4	0.1 μ F capacitor
C5	0.047 μ F capacitor
C6	0.01 μ F capacitor
C7, C8, C9	47 μ F 6 V electrolytic capacitor
R1	100 k Ω potentiometer
R2	47 k Ω 1/4 W 5% resistor
R3	2.2 k Ω 1/4 W 5% resistor
R4	680 Ω 1/4 W 5% resistor
R5	220 k Ω 1/4 W 5% resistor
R6	390 Ω 1/4 W 5% resistor
R7	1.2 k Ω 1/4 W 5% resistor
R8, R10, R12, R14, R16	10 k Ω 1/4 W 5% resistor
R9	3.3 k Ω 1/4 W 5% resistor
R11, R13, R15	33 k Ω 1/4 W 5% resistor

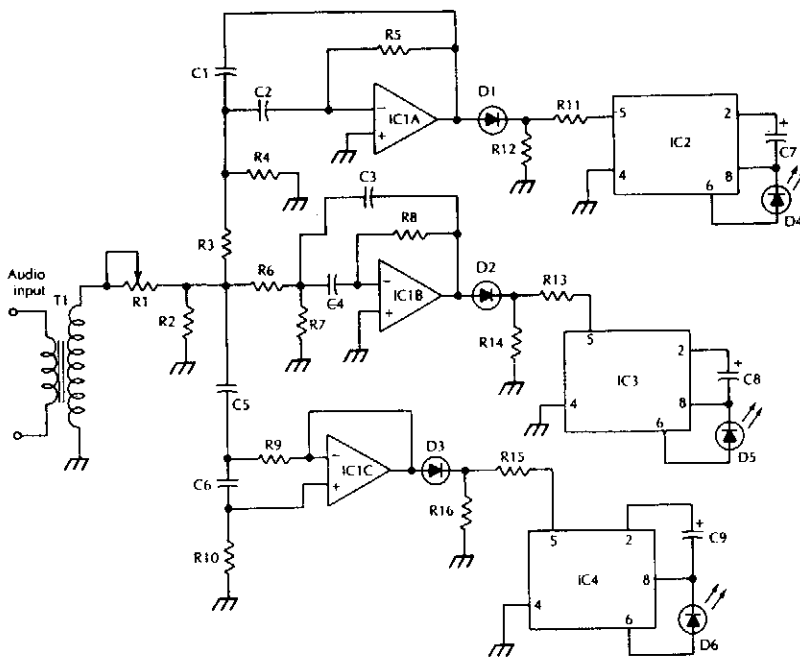

McGRAW-HILL

Fig. 28-6

Three active filters that divide the audio spectrum into three bands drive rectifiers and then drive IC2, 3, and 4, flashing the LEDs at 6 Hz. D4, D5, and D6 should be three different colors for best effect.

VOICE LEVEL METER

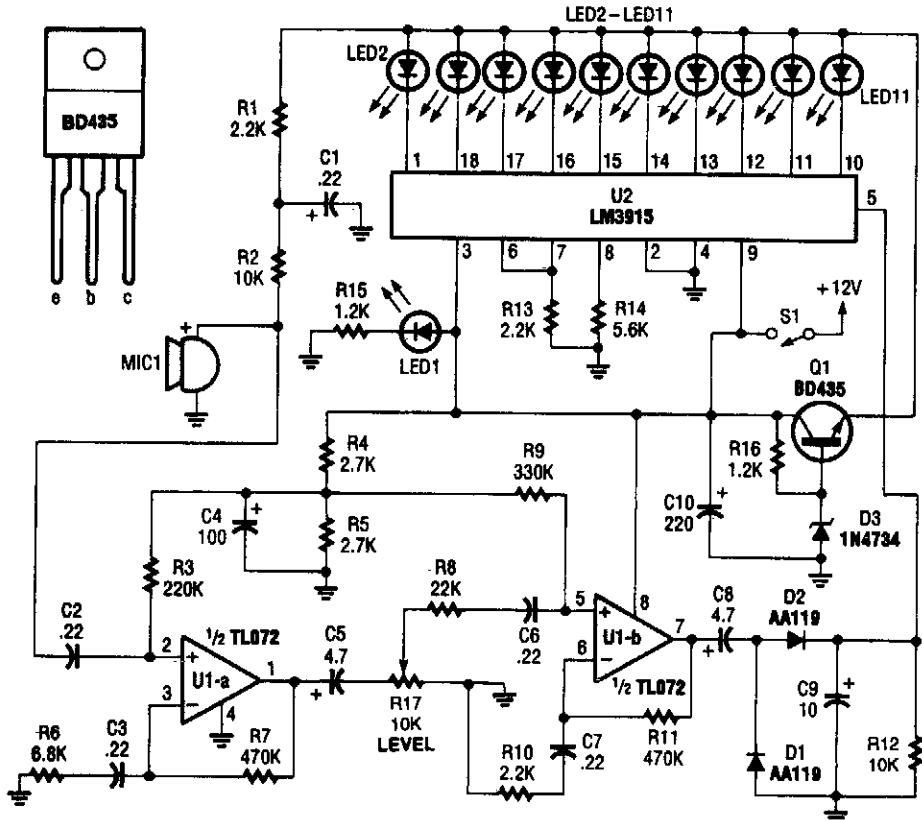

This volume meter can be handy anywhere you need to measure the relative sound level in a room. It is readily adjustable to increase its usefulness.

Using an LM3915 VU meter LED bar graph driver, 10 LEDs are driven. A simple audio amplifier drives a detector circuit, which provides dc drive for the LM3915.

LCD CONTRAST TEMPERATURE COMPENSATOR

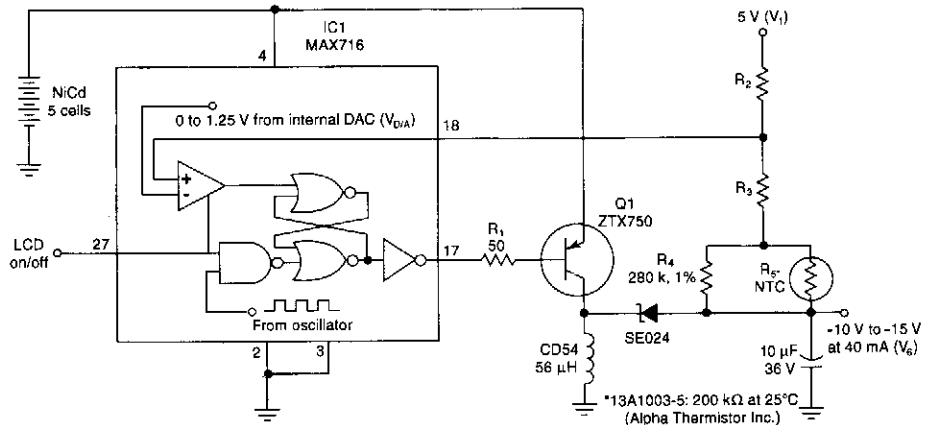

Fig. 28-8

ELECTRONIC DESIGN

Negative temperature-coefficient resistor R_5 modifies feedback in this switching regulator, which results in a negative output voltage that varies with temperature. With properly chosen resistor values, the circuit produces a temperature-compensated bias voltage that ensures constant contrast in an LCD.

LED BARGRAPH DRIVER CIRCUIT

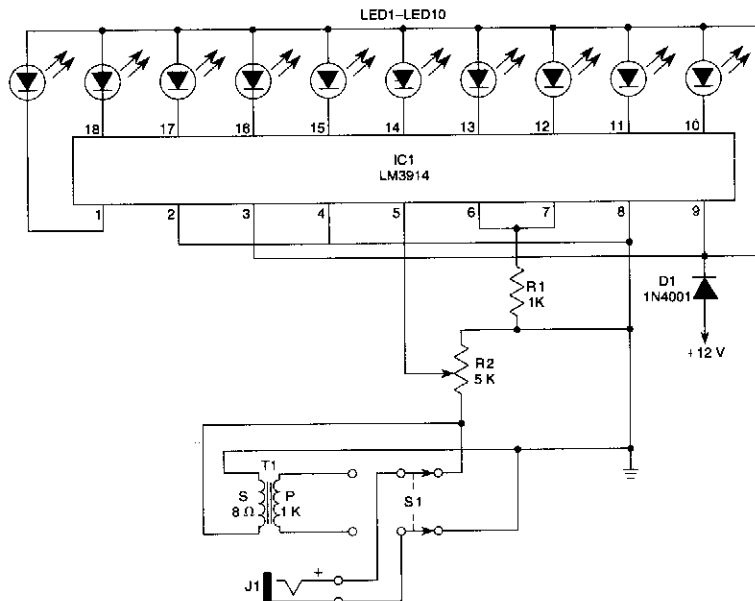

Fig. 28-9

ELECTRONICS NOW

This circuit is used as an audio indicator. S_1 selects direct input or a 1-k Ω (high impedance) audio input. R_2 is a sensitivity control.

29

Driver Circuits

The sources of the following circuits are contained in the Sources section, which begins on page 707. The figure number in the box of each circuit correlates to the entry in the Sources section.

Two-Input Video MUX Cable Driver
Impedance-Matched Line Driver with 75- Ω Load
Tests Driver for Hobby Servos
Stereo Line Driver
High-Speed Shield/Line Driver
Simple Neon Light Driver
High-Side MOSFET Driver
TTL-Based Speaker Driver
Low-Distortion Composite ± 100 -mA Line Driver
Video Cable Driver
Coax Cable Driver
Ultra Low Distortion ± 50 -mA Driver
Very Efficient Solenoid Driver

TWO-INPUT VIDEO MUX CABLE DRIVER

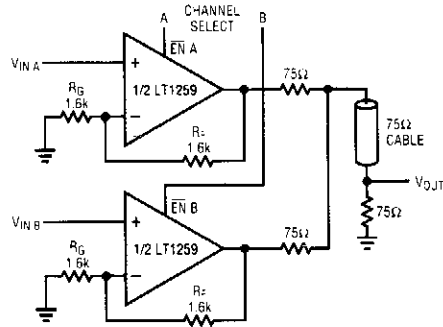

LINEAR TECHNOLOGY

Fig. 29-1

IMPEDANCE-MATCHED LINE DRIVER WITH 75-Ω LOAD

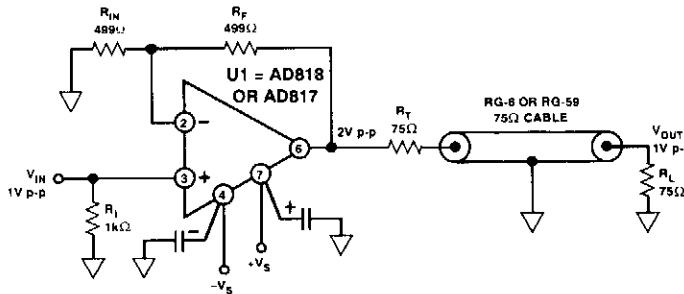

ANALOG DIALOG

Fig. 29-2

This circuit is a wideband 75-Ω line driver, for video applications (1 V p-p into 75 Ω).

TESTS DRIVER FOR HOBBY SERVOS

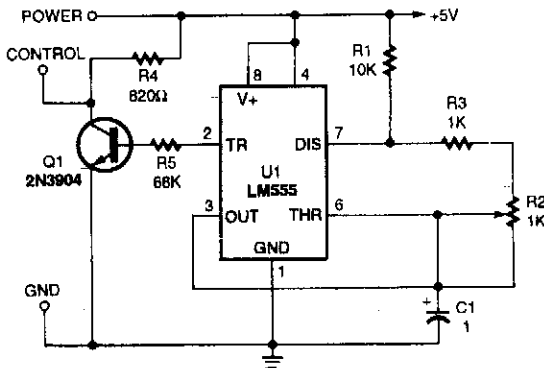

This circuit will generate the pulse used to control hobby servos. With the components shown the servo should produce a 90° total rotation.

POPULAR ELECTRONICS

Fig. 29-3

STEREO LINE DRIVER

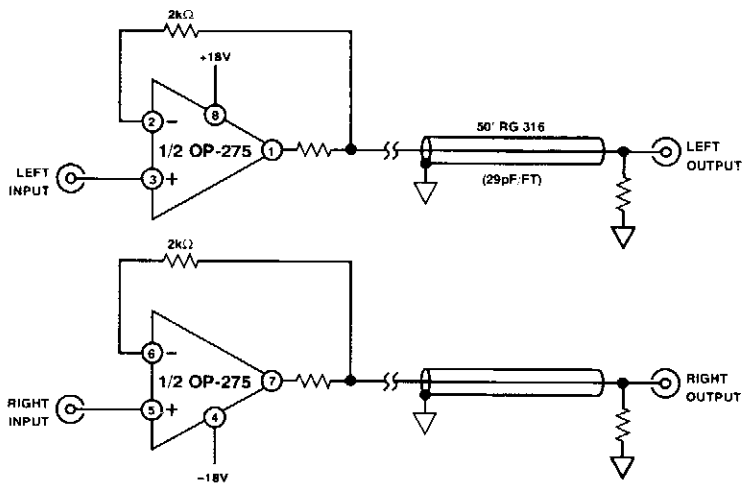

ANALOG DEVICES

Fig. 29-4

One Analog Devices OP-275 can be used for stereo line driver applications.

HIGH-SPEED SHIELD/LINE DRIVER

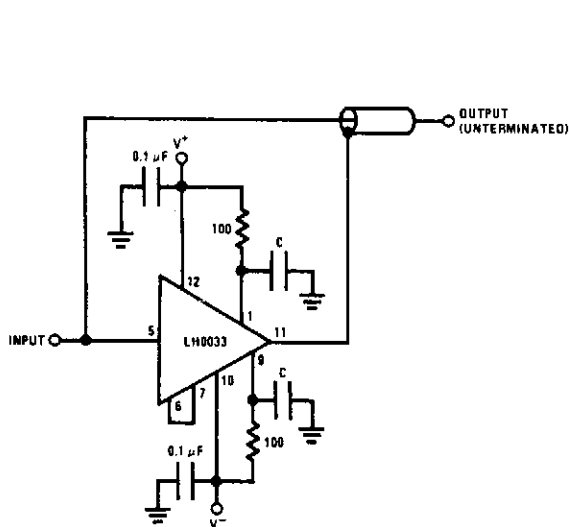

NATIONAL SEMICONDUCTOR

Fig. 29-5

SIMPLE NEON LIGHT DRIVER

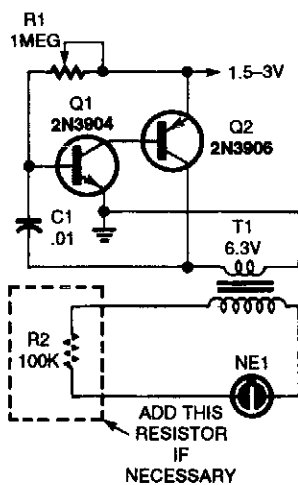

POPULAR ELECTRONICS

Fig. 29-6

NE1, a neon lamp, is lit by this simple inverter circuit. T1 is a 20:1 turn ratio transformer (transistor radio output, etc.).

HIGH-SIDE MOSFET DRIVER

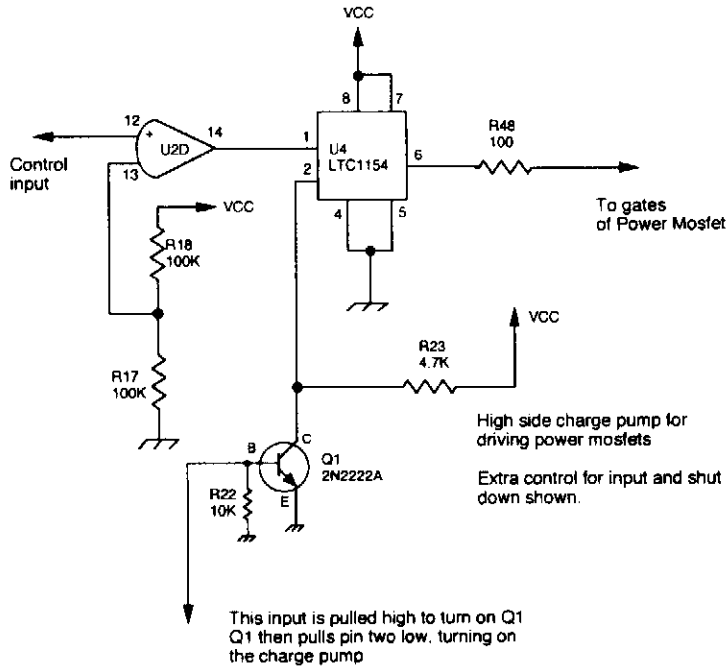

73 AMATEUR RADIO TODAY

Fig. 29-7

A Linear Technology LTC1154 is used as a charge pump to drive the gate of a high-side power MOSFET.

TTL-BASED SPEAKER DRIVER

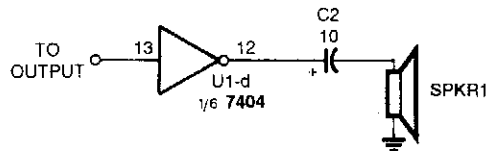

POPULAR ELECTRONICS

Fig. 29-8

A TTL IC, such as a 7404, can drive a small speaker with enough audio to be used as an alarm or annunciator. The speaker can be a 32- or 100- Ω unit.

LOW-DISTORTION COMPOSITE $\pm 100\text{-mA}$ LINE DRIVER

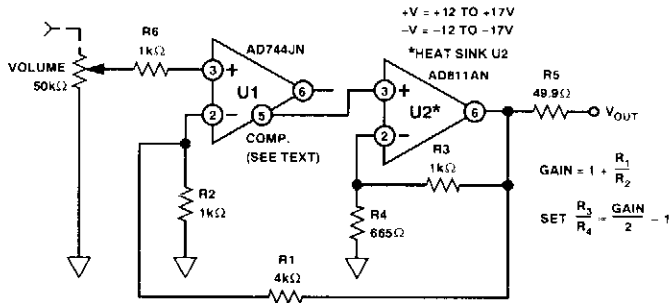

ANALOG DEVICES

Fig. 29-9

This line driver combines the high input impedance of an FET-input IC and a 100-mA op amp. U1's output is left open. The compensation terminal (pins) drive U2's high-Z input for increased overall phase margin. Gain is 14 dB, THD $+N$ at 5 V, and RMS output is around 0.001% below 20 kHz.

VIDEO CABLE DRIVER

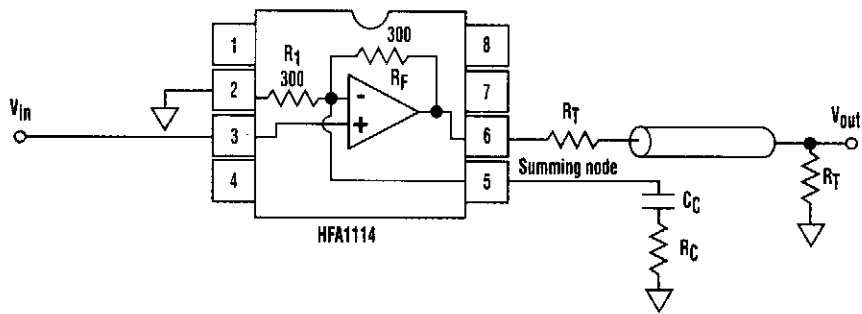

ELECTRONIC DESIGN

Fig. 29-10

The driver's frequency response is tunable for a specific cable length via components connected to the summing node. By shunting R_1 , R_c acts to increase the amplifier's gain, and C_c controls the cut-off frequency of the compensation.

These three components peak the amplifier's frequency response to counteract the cable's roll-off characteristic. By squeezing more bandwidth out of a given cable, higher-performance cables aren't needed.

COAX CABLE DRIVER

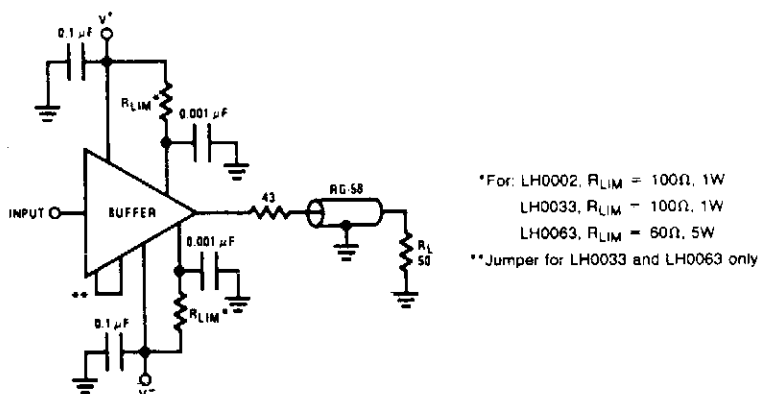

NATIONAL SEMICONDUCTOR

Fig. 29-11

Because of their high-current drive capability, the LH0002, LH0033, and LH0063 buffer amplifiers are suitable for driving terminated or unterminated coaxial cables, and high-current or reactive loads. Current-limiting resistors should be used to protect the device from excessive peak load currents or accidental short circuit. No current limiting is built into the devices other than that imposed by the limited beta of the output transistors. This figure shows a coaxial-cable drive circuit. The 43- Ω resistor is included, the output voltage to the load is about half what it would be without the near-end termination.

ULTRA LOW DISTORTION ± 50 -mA DRIVER

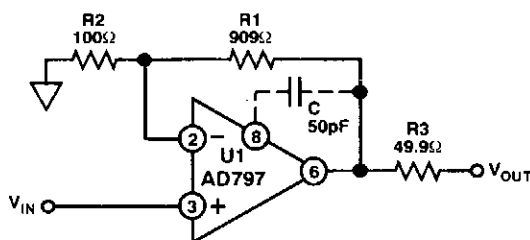

ANALOG DEVICES

Fig. 29-12

For a 600- Ω load, THD is typically -115 dB at 20 kHz, 3-V RMS output, with ± 15 -V supplies. The -3 -dB BW is 6 MHz.

VERY EFFICIENT SOLENOID DRIVER

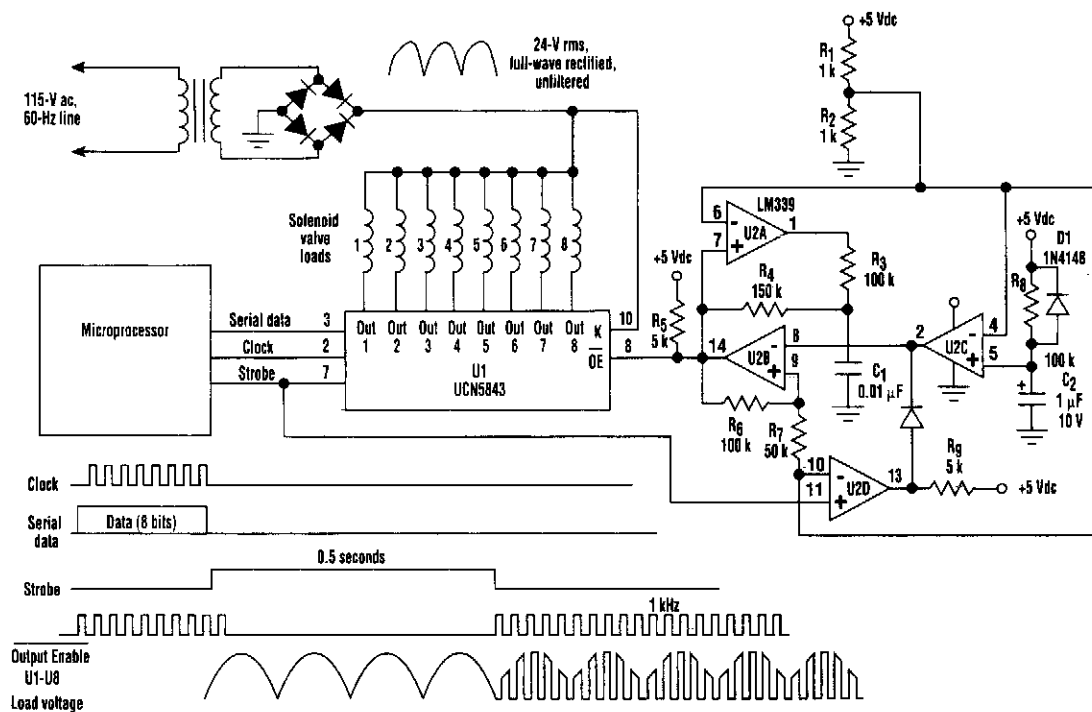

Fig. 29-13

ELECTRONIC DESIGN

In the circuit shown, the IC in the center, U1, contains a microprocessor-compatible serial-in, parallel-out shift register, with strobed latch and high-level solenoid drives (see the figure).

The strobe pulse turns on the selected loads at full power for its pulse width, which is 0.5 second. Following the strobe pulse, the driver outputs are pulse-width modulated by the multivibrator, which is set for a duty cycle of 25%. The solenoids are therefore held in the engaged position with a voltage that's 25% of the nominal supply voltage.

U2B acts as the basic multivibrator in the circuit, and U2A sets the duty cycle by setting the discharge current of capacitor C1. U2D overrides the oscillation during the strobe pulse. And U2C provides the Power-On Reset (POR), inhibiting the solenoid loads from turning on during the initialization period of the microprocessor.

30

Electronic Lock Circuits

The sources of the following circuits are contained in the Sources section, which begins on page 707. The figure number in the box of each circuit correlates to the entry in the Sources section.

Electronic Lock
Frequency-Based Lock
Simple Lock

ELECTRONIC LOCK

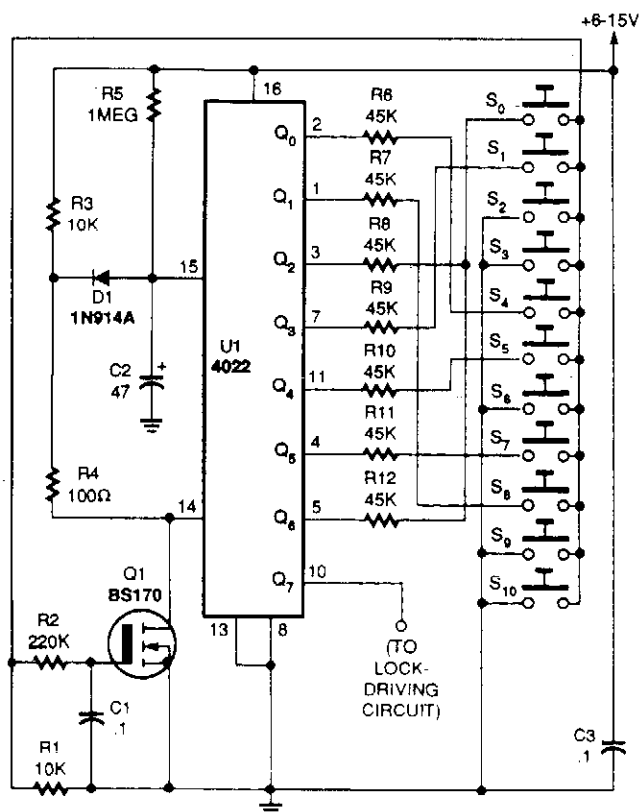

POPULAR ELECTRONICS

Fig. 30-1

The heart of the circuit is a 4022 octal counter. When first powered up, $C2$ is charged via $R5$, so the reset input of the counter is kept high. That causes output Q_0 to go high while all other outputs are low. With the switches wired as shown, when S_4 is pressed, the BS170 is switched on via debouncing network $R2/C1$, and $U1$ receives a clock pulse. Also, $C2$ is discharged via $R4$ and $D1$, removing the reset signal of the counter, allowing it to advance. The time required for $C2$ to charge via $R5$ (i.e., to reset the counter), is the maximum time that can lapse before the next key is pressed. The above cycle is therefore repeated only if S_8 (connected to the Q_1 output) is pressed in time. When all keys have been pressed in time and in the correct order, Q_7 goes high for about four seconds to drive the "unlock" circuitry (e.g., a relay driver for an automatic door opener. A builder can change the code by reviewing the switches. The code for the lock shown in the circuit diagram is 4-8-0-1-5-7-0. However, the 4022 octal counter can be replaced by a 4017 divide-by-10 counter. That will make it possible to add two more digits to the combination.

FREQUENCY-BASED LOCK

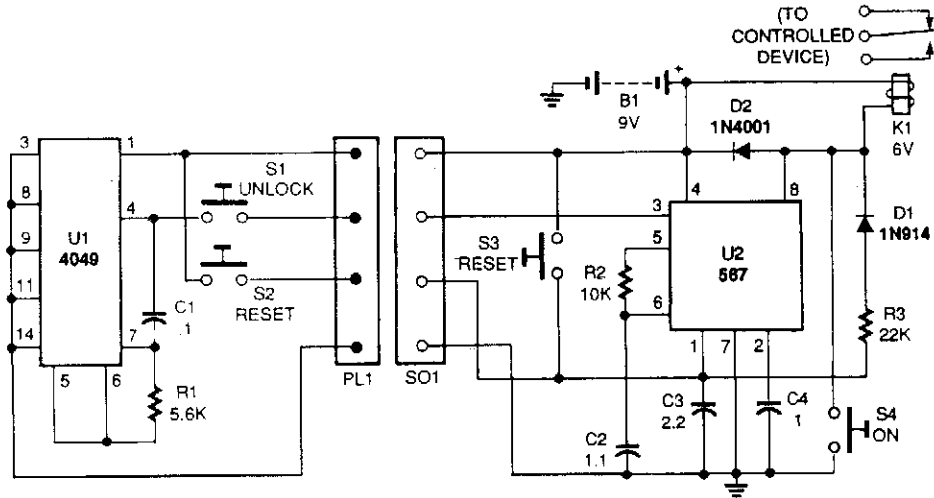

POPULAR ELECTRONICS

Fig. 30-2

The system is formed by two separate circuits—a key and a keyhole. The key engages the keyhole with a mating pair of connectors. The key is a tone-generator circuit consisting of a 4049 hex inverter CMOS IC (U1), switches (S1 and S2), a resistor (R1), and a capacitor (C1). The value of the tone generated by that circuit in Hz is determined by;

$$\frac{1}{(1.4 \times R_1 C_1)}$$

The keyhole is a 567 tone-decoder circuit that can be configured to detect any frequency from 0.01 Hz to 500 kHz. The frequency it detects (f_0), via the 567 IC, turns on the relay (K1). Components R3 and D1 are used to latch the circuit, so the output stays on even after the input tone is removed. When S2 is pressed, the system is reset. Switch S3 resets the circuit from inside.

SIMPLE LOCK

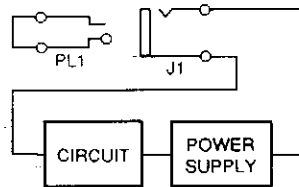

POPULAR ELECTRONICS

Fig. 30-3

Only an appropriately wired plug of the right size will activate circuits with a nonshorting jack in their power supply circuit.

31

Fiber-Optics Circuits

The sources of the following circuits are contained in the Sources section, which begins on page 707. The figure number in the box of each circuit correlates to the entry in the Sources section.

Experimental Data Transmitter for Fiber Optics
Experimental Fiber-Optic Data Receiver

EXPERIMENTAL DATA TRANSMITTER FOR FIBER OPTICS

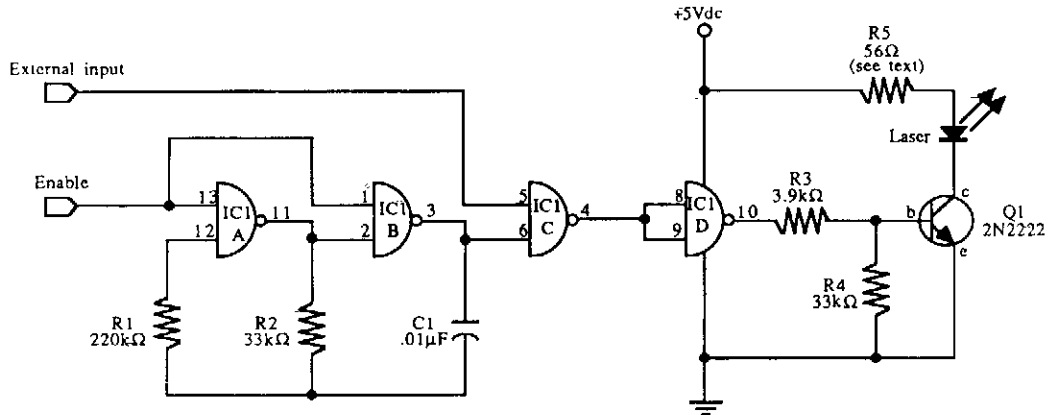

McGRAW-HILL

Fig. 31-1

This schematic for an experimental data transmitter uses optical fibers and a laser diode. Transmission frequency of the free-running oscillator is approximately 3 kHz. R5 might have to be varied to suit your laser diode. IC1 is a CD4093.

EXPERIMENTAL FIBER-OPTIC DATA RECEIVER

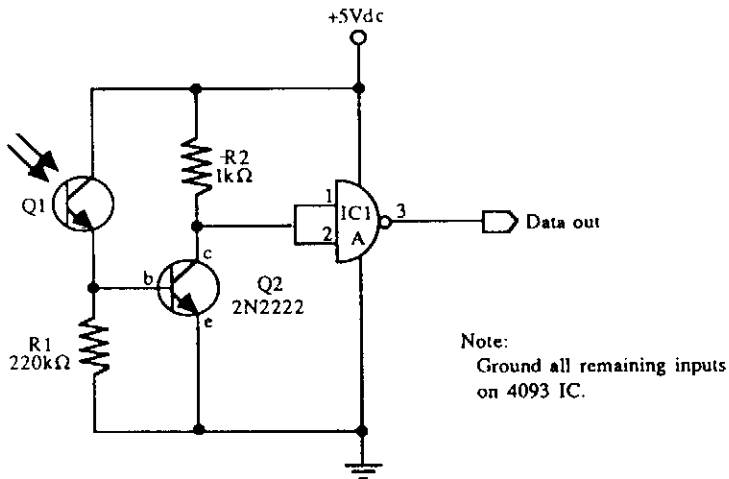

McGRAW-HILL

Fig. 31-2

An infrared phototransistor acts as the sensor for this receiver. IC1a is a section of a CD4093 CMOS NAND gate.

32

Filter Circuits

The sources of the following circuits are contained in the Sources section, which begins on page 707. The figure number in the box of each circuit correlates to the entry in the Sources section.

- | | |
|---|--|
| State Variable Filter | Single 3.3-V Supply 4-Pole State Variable Filter |
| Sallen-Key High-Pass Filter | High-Q Notch Filter |
| Active Bandpass Filter Circuit | Adjustable Q Notch Filter |
| High-Pass Filter | Digital Comb Filter |
| Second-Order Voltage-Controlled Filter | Voltage-Controlled Low-Pass Filter |
| Combination Filter | VSB Filter for LM2889 |
| Shortwave Receiver IF Filter | 20-kHz Butterworth Active Filter |
| Pin Diode Filter Selection Circuit | Bandpass Filter |
| High-Pass Active Filter | Sallen-Key Low-Pass Filter |
| AM Broadcast Trap for Simple SW Receivers | Active High-Pass Filter |
| Shortwave Interference Trap | RC Notch Filter |
| Programmable Analog Filter | 1-kHz 4th-Order Butterworth Filter |
| Active Low-Pass Filter | Saw-Filter Impedance-Matching Preamplifier |
| Two Op-Amp Bandpass Filter | One Op-Amp Bandpass Filter |

STATE VARIABLE FILTER

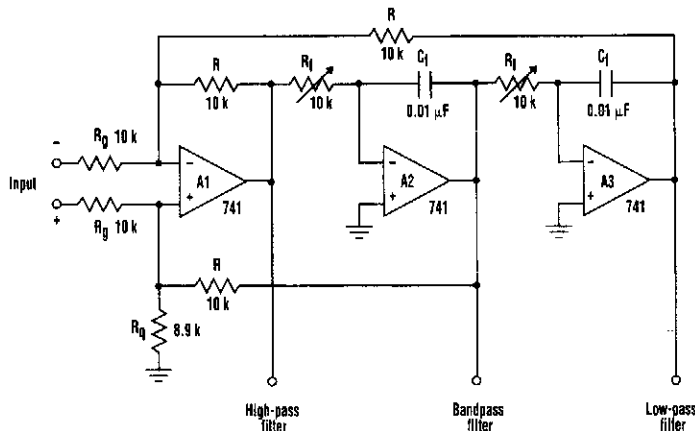

Fig. 32-1

ELECTRONIC DESIGN

The state variable filter shown consists of only three op amps and a few passive components. It provides several key features. These include the ability to simultaneously provide low-pass, high-pass, and bandpass filter functions, and adjust bandwidth in a wide range by changing the values of C_1 and R_f . The device also is easy to tune and simple to construct, while the quality factor (Q) of each filter is independent of each other.

SALLEN-KEY HIGH-PASS FILTER

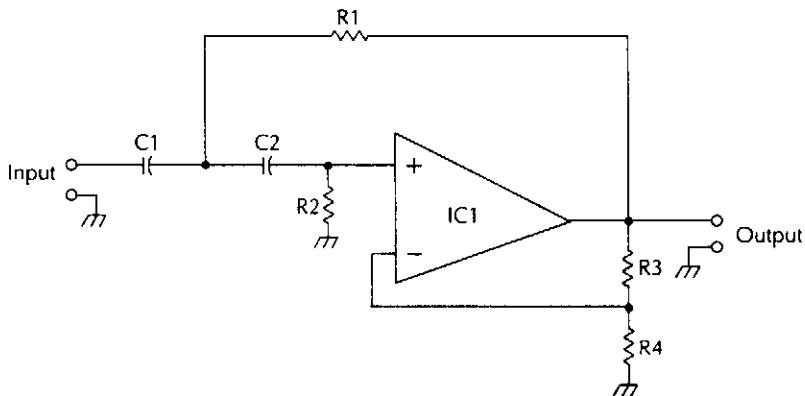

Fig. 32-2

McGRAW-HILL

R_3 and R_4 set the circuit gain

$$f_c = \frac{1}{2\pi\sqrt{R_1 R_2 C_1 C_2}}$$

usually $C_1 = C_2, R_1 = R_2$

$$R_3 = 0.586 R_4$$

ACTIVE BANDPASS FILTER CIRCUIT

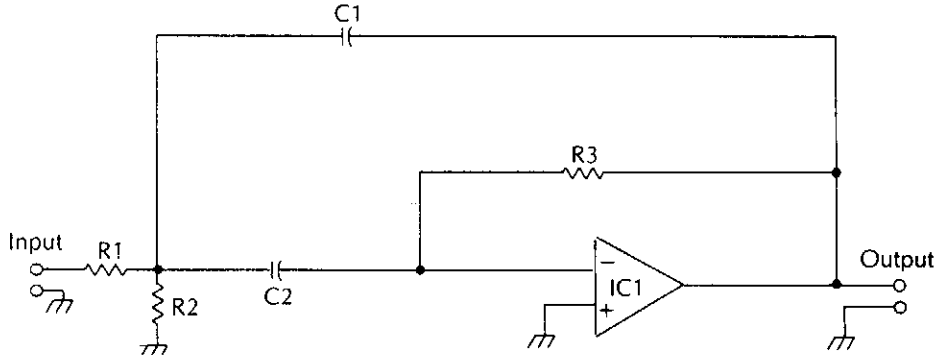

McGRAW-HILL

In this circuit,

Fig. 32-3

$$C_1 = C_2 = C$$

$$Q = \frac{f_0}{BW} \quad K = \text{circuit gain, } f_0 = \text{center frequency}$$

$$R_1 = \frac{Q}{2\pi f_0 CK}$$

$$R_2 = \frac{2Q}{2\pi f_0 C}$$

$$R_3 = \frac{Q}{2\pi f_0 C(2Q - K)}$$

HIGH-PASS FILTER

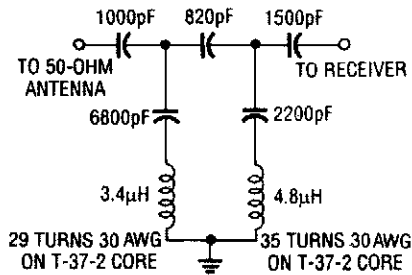

RADIO-ELECTRONICS

Fig. 32-4

This high-pass filter will attenuate AM stations by 40 dB. Its low-frequency cutoff is about 2.2 MHz. This filter is useful for SW listening in areas of high AM radio signal strength.

SECOND-ORDER VOLTAGE-CONTROLLED FILTER

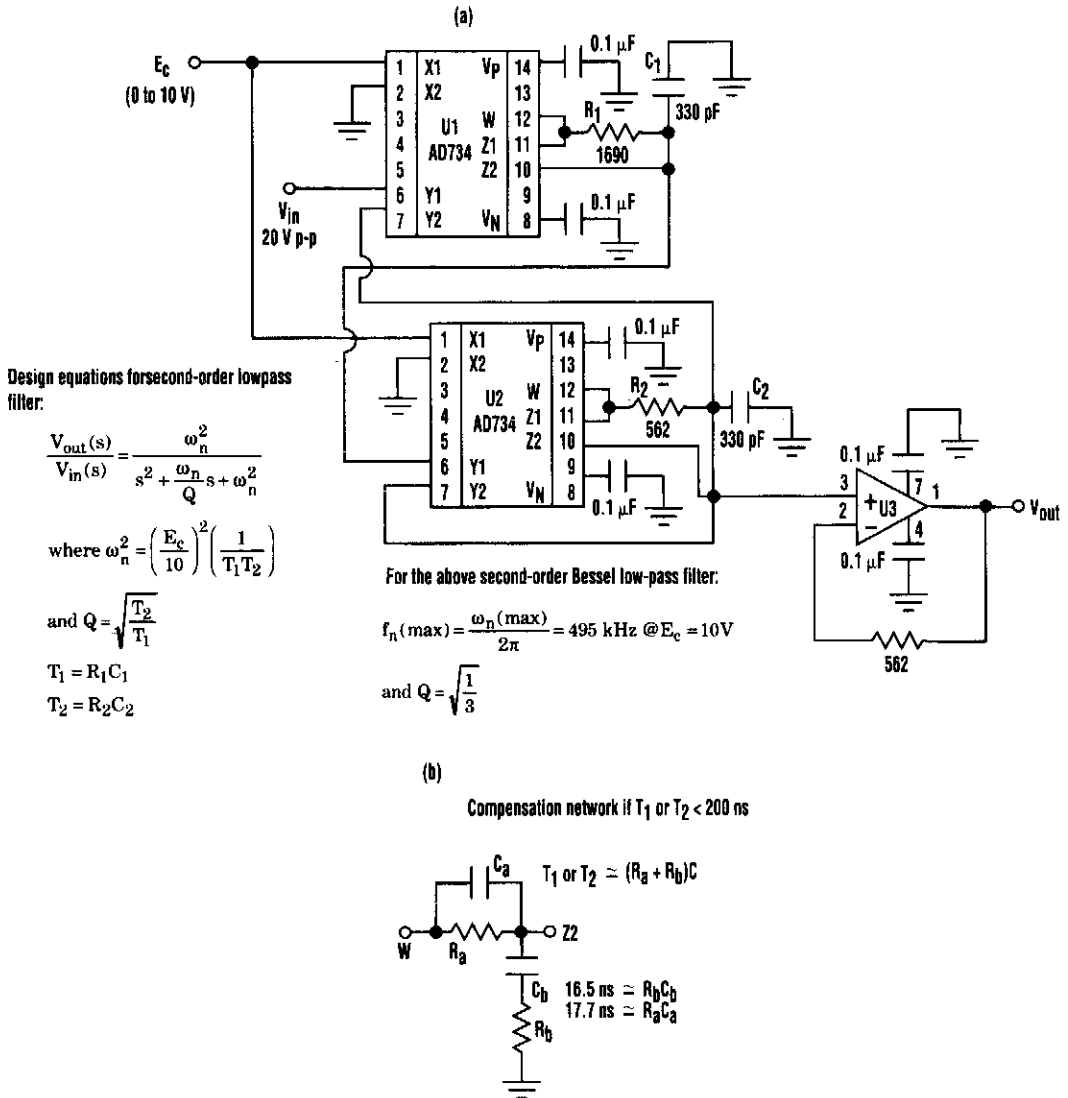

Design equations for second-order lowpass filter:

$$\frac{V_{out}(s)}{V_{in}(s)} = \frac{\omega_n^2}{s^2 + \frac{\omega_n}{Q}s + \omega_n^2}$$

$$\text{where } \omega_n^2 = \left(\frac{E_c}{10}\right)^2 \left(\frac{1}{T_1 T_2}\right)$$

$$\text{and } Q = \sqrt{\frac{T_2}{T_1}}$$

$$T_1 = R_1 C_1$$

$$T_2 = R_2 C_2$$

Desirable second-order voltage-controlled low-pass filter response can be achieved with this voltage-controlled filter (A). By using low-distortion, wide-bandwidth multipliers, it achieves higher cutoff frequencies than switched-capacitor filters. If the circuit's RC network has a time constant less than 200 ns, it should be replaced by a lag compensator network (B).

COMBINATION FILTER

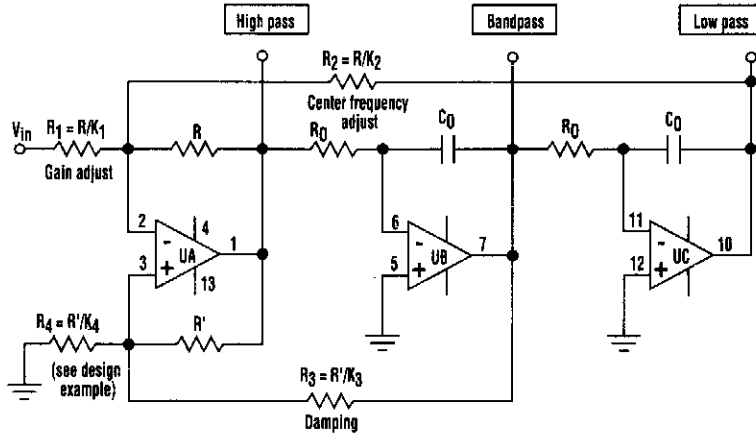

ELECTRONIC DESIGN

Fig. 32-6

The classic “state variable” two-integrator filter is known for its insensitivity to component variations, and its ability to provide three separate simultaneous outputs—low pass, high pass, and bandpass.

Typically, a quad op amp is used to implement the state-variable filter. The classic configuration uses two integrating amplifiers, a filter input amplifier, and a filter feedback amplifier.

The design described here combines both input and feedback amplifiers into one adder/subtractor amplifier, achieving a three op-amp filter design (see the figure).

SHORTWAVE RECEIVER IF FILTER

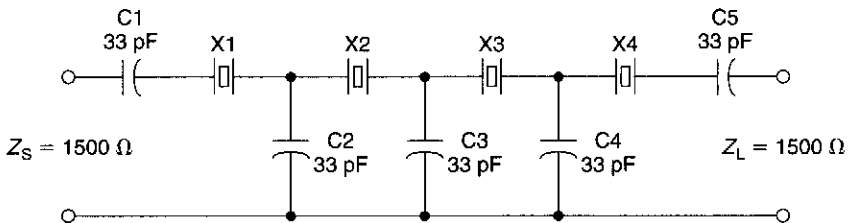

3-MHz IF filter
 $BW = 700 \text{ Hz}$
 $IL \approx 4 \text{ dB}$

X_1 through X_4 3.000 MHz $\pm 50 \text{ Hz}$
 $C_x = C_1$ through C_5 33 pF $\pm 5\% \text{ NPO}$

WILLIAM SHEETS

Fig. 32-7

An inexpensive filter can be made from microprocessor crystals. This filter has 700 Hz BW (3 dB) and has a flat response ($<1 \text{ dB}$) for about 400 to 500 Hz. Although a 3-MHz crystal was used, any frequency from 2 to 15 MHz (using fundamental crystal) should work, with appropriate scaling of components. Crystal resonant frequencies should match within 20% and preferably 10% of expected bandwidth (which is narrower as C_x increases. Impedance is reduced with wider bandwidths.

PIN DIODE FILTER SELECTION CIRCUIT

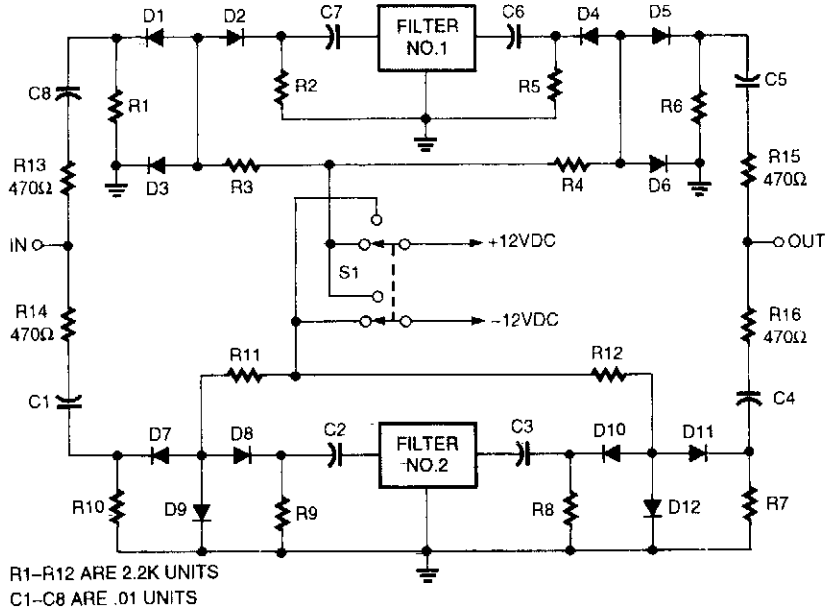

POPULAR ELECTRONICS

Fig. 32-8

Selecting IF bandpass filters via series/shunt PIN-diode switching can be accomplished with this circuit.

HIGH-PASS ACTIVE FILTER

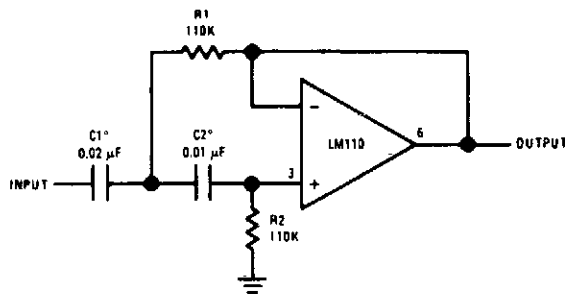

*Values are for 100 Hz cutoff. Use metallized polycarbonate capacitors for good temperature stability

NATIONAL SEMICONDUCTOR

Fig. 32-9

AM BROADCAST TRAP FOR SIMPLE SW RECEIVERS

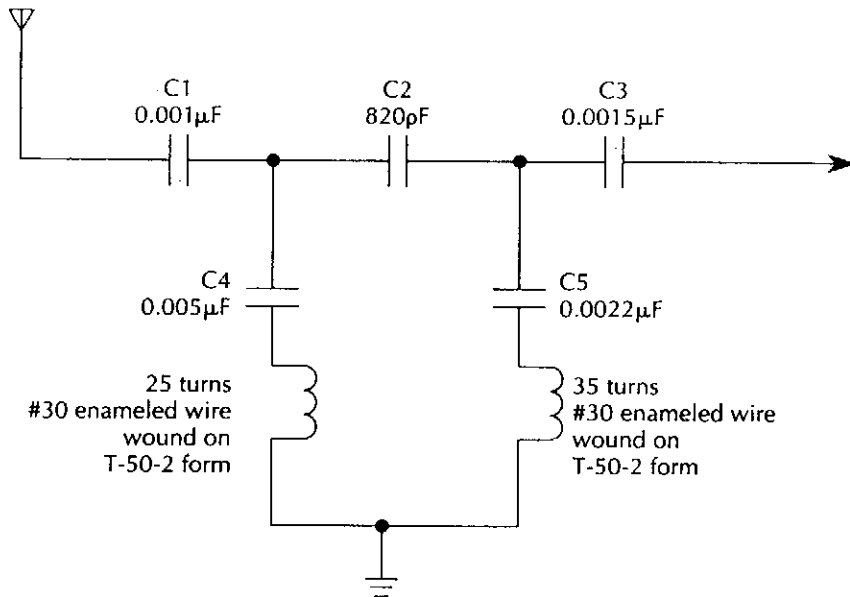

McGRAW-HILL

Fig. 32-10

SHORTWAVE INTERFERENCE TRAP

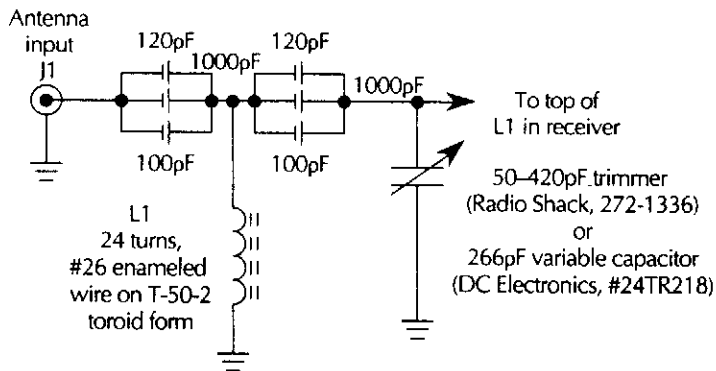

McGRAW-HILL

Fig. 32-11

Build this interference trap to help block strong shortwave, broadcast, and FM stations from coming in on the shortwave bands.

PROGRAMMABLE ANALOG FILTER

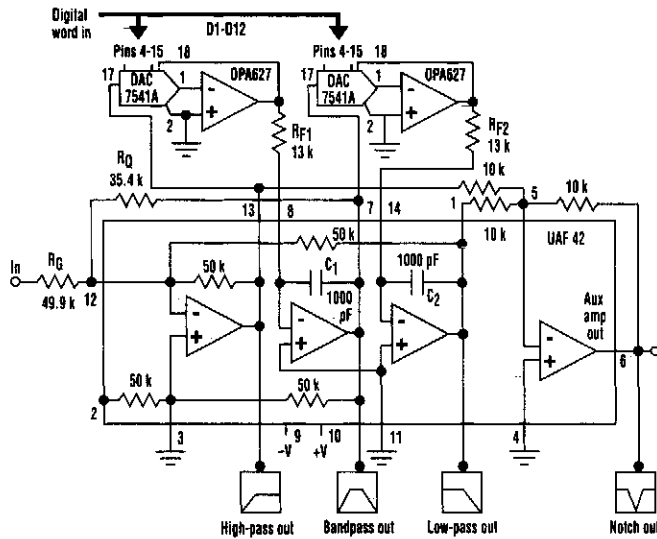

Fig. 32-12

ELECTRONIC DESIGN

The circuit in the figure shows how an analog, digitally programmable filter can be built using a UAF42. This monolithic, state-variable active filter chip provides a two-pole filter building block with low sensitivity to external component variations. It eliminates aliasing errors and clock feed through noise common to switched-capacitor filters. Low-pass, high-pass, bandpass, and notch (band-reject) outputs are available.

ACTIVE LOW-PASS FILTER

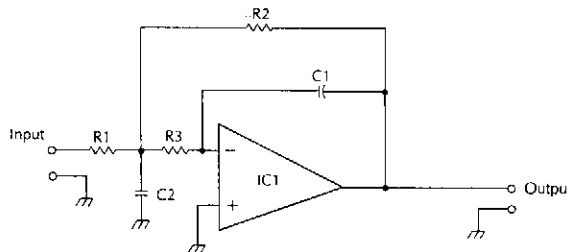

Fig. 32-13

McGRAW-HILL

In this circuit, $R_1 = 2$
 $R_2 = R_4$
 $R_3 = 2R_1$
 $C_1 = C_2$
 $f = \frac{1}{2\pi RC}$

This circuit has a rolloff of 6 dB/Octave.

TWO OP-AMP BANDPASS FILTER

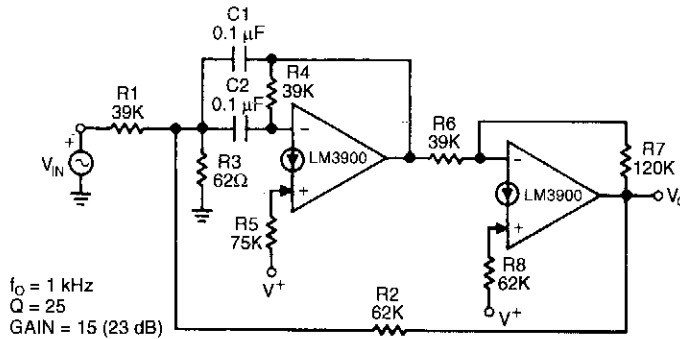

NATIONAL SEMICONDUCTOR

Fig. 32-14

This circuit uses only two capacitors. The amplifier on the right supplies a controlled amount of positive feedback for improved response characteristics. Resistors R5 and R8 are used to bias the outvoltage of the amplifiers at $V+/2$.

SINGLE 3.3-V SUPPLY 4-POLE STATE VARIABLE FILTER

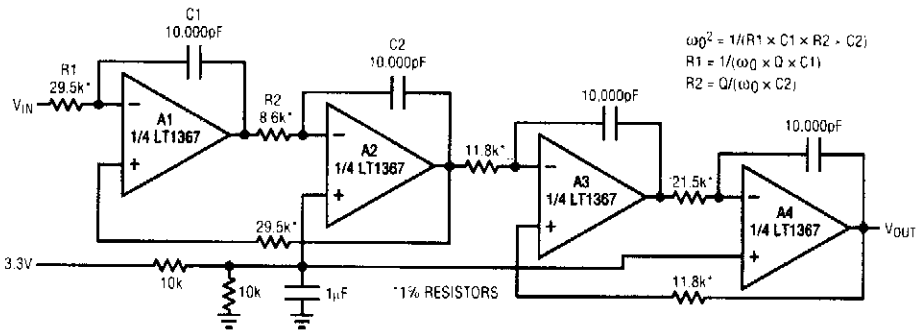

LINEAR TECHNOLOGY

Fig. 32-15

HIGH-Q NOTCH FILTER

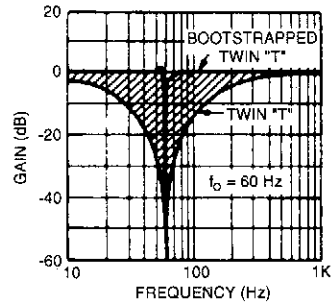
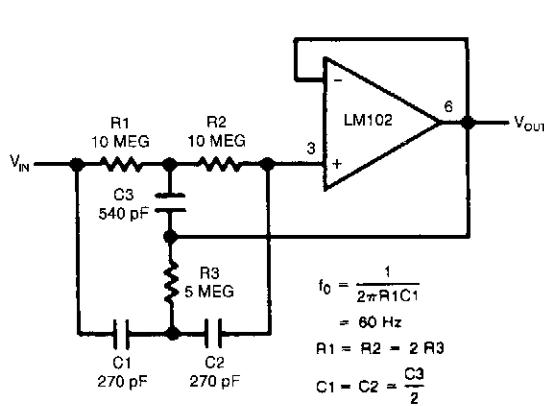

Response of High and Low Q Notch Filter

NATIONAL SEMICONDUCTOR

Fig. 32-16

This shows a twin "T" network connected to an LM102 to form a high Q , 60-Hz notch filter. The junction of R_3 and C_3 , which is normally connected to ground, is bootstrapped to the output of the follower. Because the output of the follower is a very low impedance, neither the depth nor the frequency of the notch change; however, the Q is raised in proportion to the amount of signal fed back to R_3 and C_3 .

ADJUSTABLE-Q NOTCH FILTER

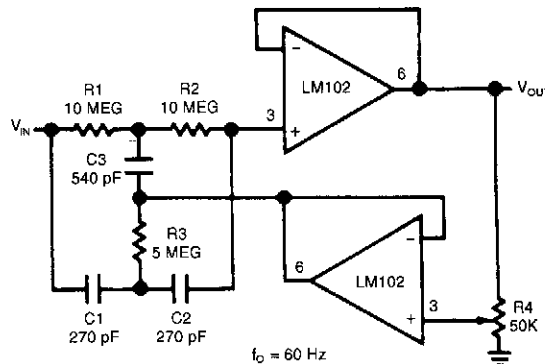

NATIONAL SEMICONDUCTOR

Fig. 32-17

This figure shows a circuit where the Q can be varied from 0.3 to 50. A fraction of the output is fed back to R_3 and C_3 by a second voltage follower, and the notch Q is dependent on the amount of signal fed back. A second follower is necessary to drive the twin "T" from a low-resistance source so that the notch frequency and depth will not change with the potentiometer setting.

DIGITAL COMB FILTER

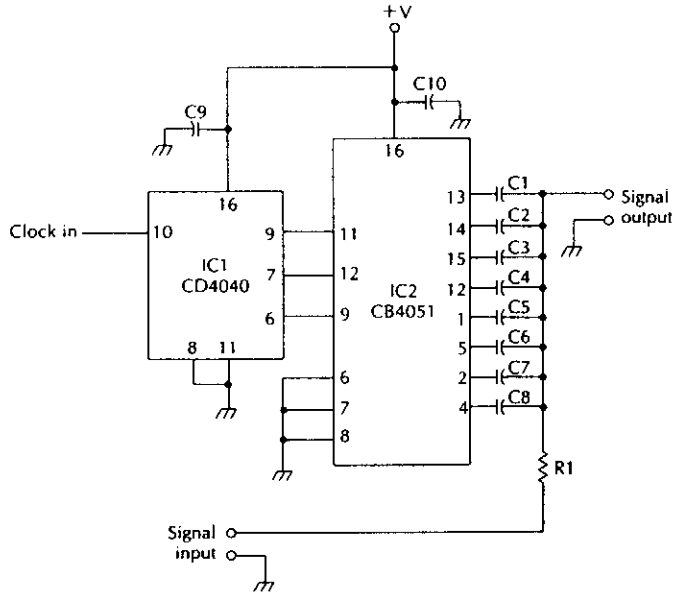

This circuit uses an eight-step switching sequence, so $n=8$. This makes the center frequency equal to:

$$\begin{aligned}
 F_c &= \frac{1}{(2nRC)} \\
 &= \frac{1}{(2 \times 8)RC} \\
 &= \frac{1}{16RC}
 \end{aligned}$$

Using the component values suggested in the parts list, the circuit has a main center frequency of:

$$\begin{aligned}
 F_c &= \frac{1}{(16 \times 1000 \times 0.00000001)} \\
 &= \frac{1}{0.00016} \\
 &= 6250 \text{ Hz}
 \end{aligned}$$

Suggested parts list for the digital comb filter

IC1	CD4040 BCD-ripple counter
IC2	CD4051 BCD-to-decimal decoder (SP8T rotary bilateral switch)
C1-C8	0.01 μ F close tolerance capacitor
C9, C10	0.1 μ F capacitor
R1	1K $\frac{1}{4}$ W 5% resistor

VOLTAGE-CONTROLLED LOW-PASS FILTER

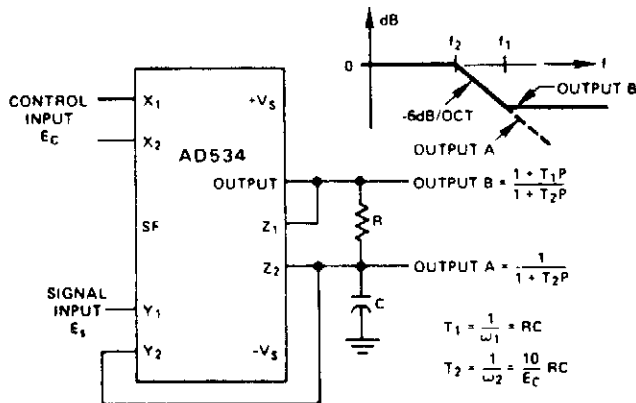

ANALOG DEVICES

Fig. 32-19

The voltage at Output A, which should be unloaded by a follower, responds as though E_s were directed to the RC filter, but the filter's break frequency were proportional to E_c [i.e., $= E_c / (20\pi RC)$]. The frequency response has a break at f_2 and the 6-dB/octave rolloff. The voltage at Output B has the same response, up to f_1 ($f_1 = 1/(2\pi RC)$), then levels off at a constant attenuation of $f_2/f_1 = E_c/10$. For example, if $R = 8 \text{ k}\Omega$, $C = 0.002 \text{ }\mu\text{F}$, Output A has a pole at 100 Hz to 10 kHz and can be loaded. The circuit can be converted to high-pass by interchanging C and R.

VSB FILTER FOR LM2889

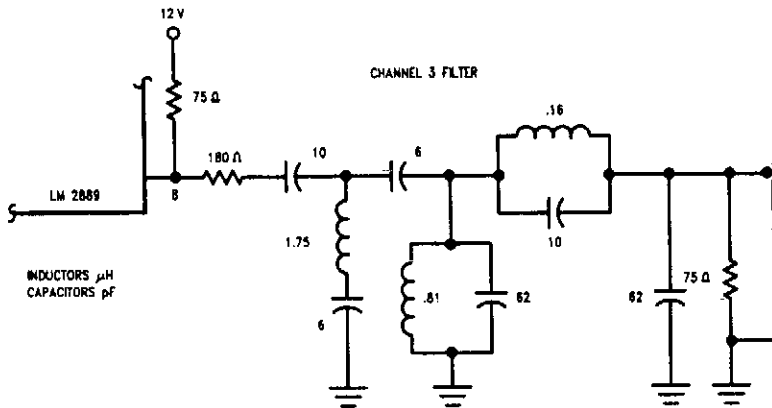

NATIONAL SEMICONDUCTOR

Fig. 32-20

This filter is for CH3, in order to get a vestigial sideband TV signal. It is designed for 75- Ω impedance levels.

20-kHz BUTTERWORTH ACTIVE FILTER

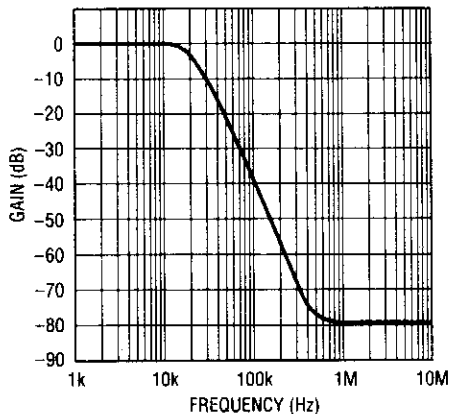
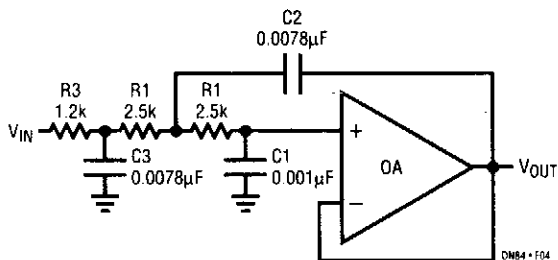

Filter Frequency Response

LINEAR TECHNOLOGY

Fig. 32-21

This filter will be useful for anti-aliasing or band limiting in an audio system. The op amp is a Linear Technology, LT1124, LT1355, or LT1169.

BANDPASS FILTER

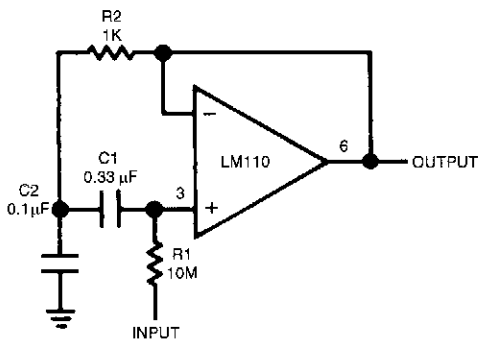

NATIONAL SEMICONDUCTOR

Fig. 32-22

SALLEN-KEY LOW-PASS FILTER

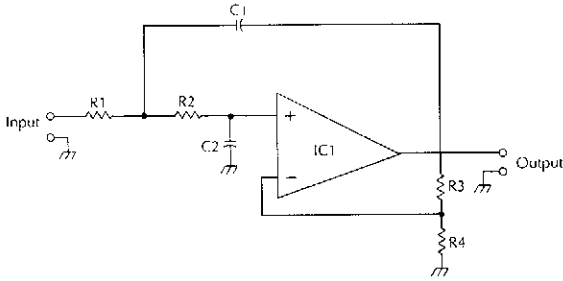

R3 and R4 set the circuit gain

$$f_c = \frac{1}{2\pi\sqrt{R_1 R_2 C_1 C_2}}$$

usually $C_1 = C_2, R_1 = R_2, R_3 = 0.586 R_4$

McGRAW-HILL

Fig. 32-23

ACTIVE HIGH-PASS FILTER

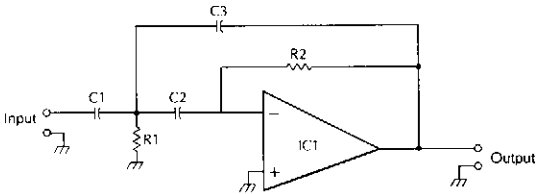

In this circuit,

$$f_{CO} = \frac{1}{2\pi RC}$$

McGRAW-HILL

Fig. 32-24

RC NOTCH FILTER

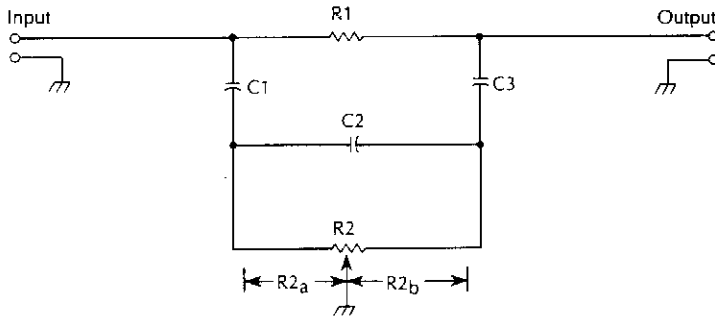

$$C_1 = C_2 = C_3$$

$$R_1 = 6R_2$$

$$R_2 = R_{2a} + R_{2b}$$

$$\text{Reject frequency (notch), } F_c = \frac{1}{2\pi C \sqrt{3R_{2a} R_{2b}}}$$

McGRAW-HILL

Fig. 32-25

1-kHz 4TH-ORDER BUTTERWORTH FILTER

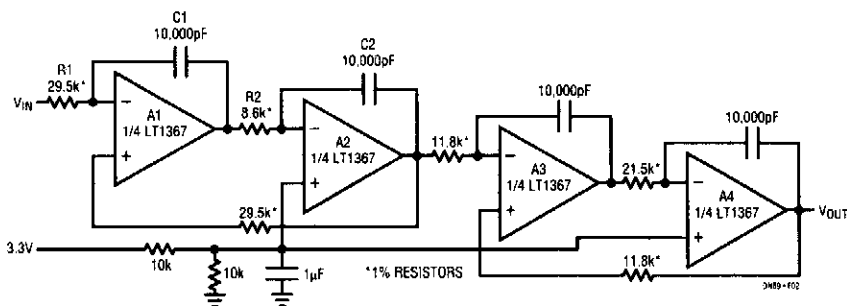

Fig. 32-26

LINEAR TECHNOLOGY

The filter is a simplified state variable architecture consisting of two cascaded 2nd-order sections. Each section uses the 360° phase shift around the two op-amp loop to create a negative summing junction at A1's positive input. The circuit has low sensitivities for center frequency and Q , which are set with the following equations:

$$\omega_0^2 = \frac{1}{(R_1 \times C_1 \times R_2 \times C_2)}$$

where,

$$R_1 = \frac{1}{(\omega_0 \times Q \times C_1)} \text{ and } R_2 = \frac{Q}{(\omega_0 \times C_2)}$$

The dc bias applied to A2 and A4, half supply, is not needed when split supplies are available. The circuit swings rail-to-rail in the passband making it an excellent anti-aliasing filter for A/Ds. The amplitude response is flat to 1 kHz then rolls off at 80 dB/decade.

SAW-FILTER IMPEDANCE-MATCHING PREAMPLIFIER

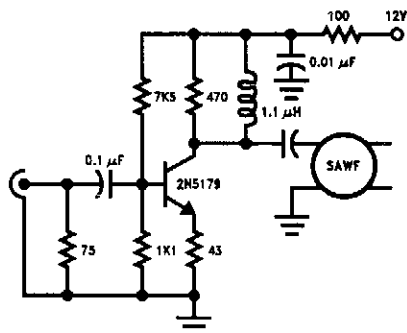

This circuit matches a saw filter to an IF amplifier.

NATIONAL SEMICONDUCTOR

Fig. 32-27

ONE OP-AMP BANDPASS FILTER

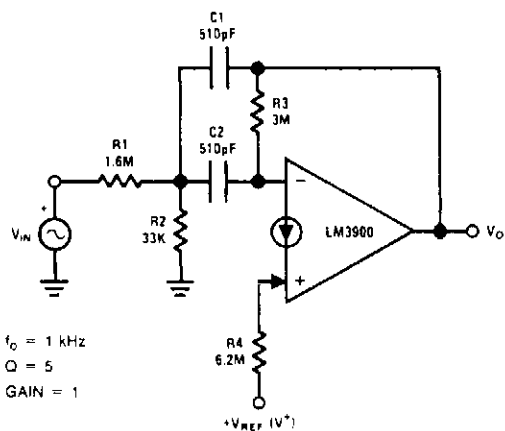

$f_0 = 1 \text{ kHz}$
 $Q = 5$
 GAIN = 1

NATIONAL SEMICONDUCTOR

Fig. 32-28

33

Flasher Circuits and Blinker

The sources of the following circuits are contained in the Sources section, which begins on page 707. The figure number in the box of each circuit correlates to the entry in the Sources section.

- Random LED Strobe
- Flashing Neon Christmas Lights
- Flashing Christmas LED Display
- Dual Flasher Add-On for 555 Circuits
- Variable-Frequency High-Power LED Flasher
- LED Pulser
- LED Pulser with Audible Output
- Simple Lamp Pulser
- LED Flasher

FLASHING NEON CHRISTMAS LIGHTS

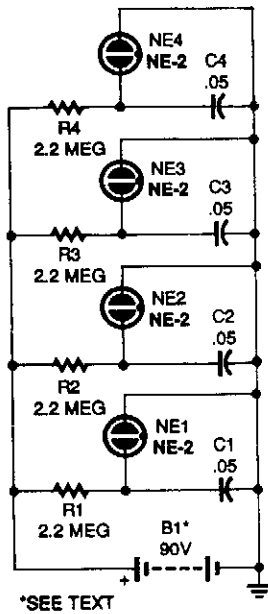

POPULAR ELECTRONICS

Fig. 33-2

This flashing set of neon Christmas lights will make an attractive decoration for any time of year. B1 is made up of ten 9-V transistor radio batteries in series. The battery life can be measured in months.

FLASHING CHRISTMAS LED DISPLAY

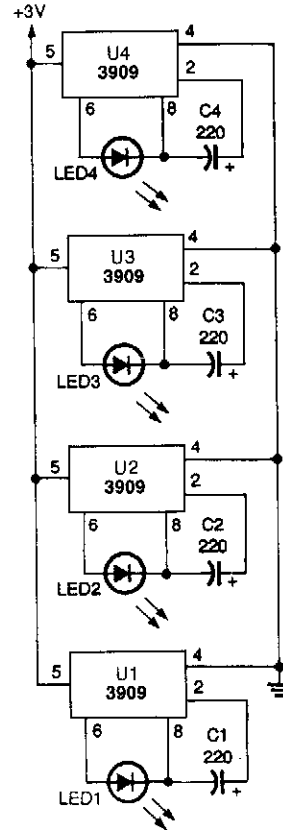

POPULAR ELECTRONICS

Fig. 33-3

Using LEDs and 3909 ICs, you can make a flashing-light circuit that will run for months on two AA batteries.

DUAL FLASHER ADD-ON FOR 555 CIRCUITS

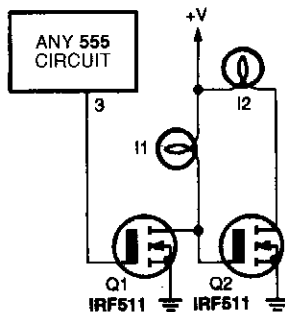

POPULAR ELECTRONICS

Fig. 33-4

A pair of hex FETs drive two incandescent lamps in an alternating flasher circuit. The lamps can be 12-V automotive types, etc.

VARIABLE-FREQUENCY HIGH-POWER LED FLASHER

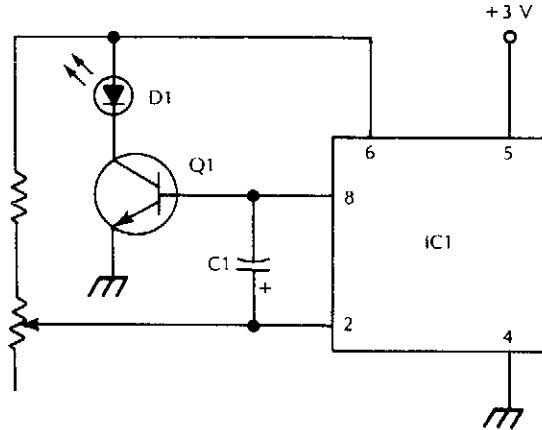

- IC1 LM3909 LED flasher/oscillator IC
 Q1 NPN transistor (2N3904, Radio Shack RS2009 or similar)
 D1 LED
 C1 100 μ F 5 V electrolytic capacitor
 R1 470 Ω 1/4 W 5% resistor
 R2 50 k Ω potentiometer

McGRAW-HILL

Fig. 33-5

LED PULSER

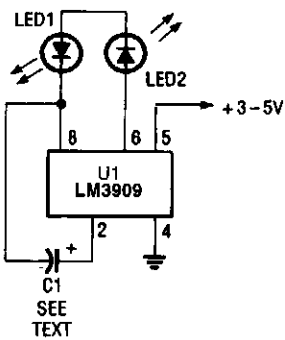

POPULAR ELECTRONICS

Fig. 33-6

In this circuit, the LM3909 is used to drive a pair of series-connected LEDs.

LED PULSER WITH AUDIBLE OUTPUT

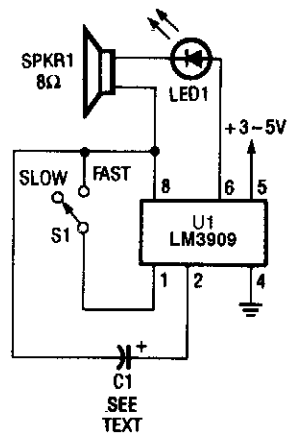

POPULAR ELECTRONICS

Fig. 33-7

The LM3909 can also be used to drive both an LED and a speaker. In this circuit, each time that LED1 blinks, SPKR1 (an 8- Ω speaker) emits a sharp click sound.

SIMPLE LAMP PULSER

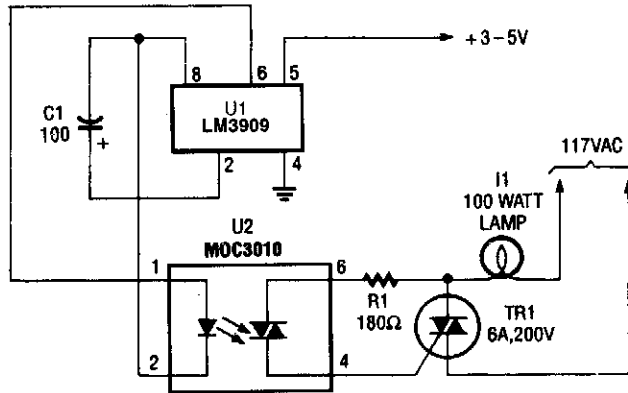

POPULAR ELECTRONICS

Fig. 33-8

Here, the LM3909 (configured as a timing oscillator) is used to control a 117-Vac lamp through an MOC3010 optoisolator/coupler.

LED FLASHER

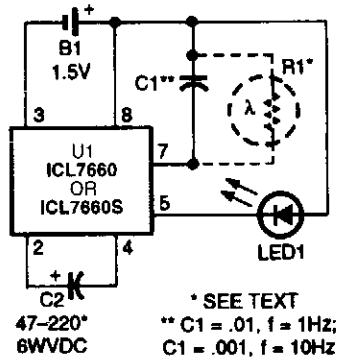

POPULAR ELECTRONICS

Fig. 33-9

This circuit provides a low-cost way to flash an LED from a single 1.5-V source. Based on the ICL7660 dc-to-dc voltage converter, the circuit makes use of an external capacitance (C1) on the oscillator rate-control pin to decrease the charge/dump time to the desired flash rate. A dc resistance (R1) on the same pin can also be used to disable the oscillator and extend the power-cell's life. That optional dc resistance (in the form of a photoconductive cell) will shut off the oscillator in daylight.

34

Flip-Flop Circuits

The sources of the following circuits are contained in the Sources section, which begins on page 707. The figure number in the box of each circuit correlates to the entry in the Sources section.

Trigger Flip Flop
Two-Amplifier Flip Flop

TRIGGER FLIP FLOP

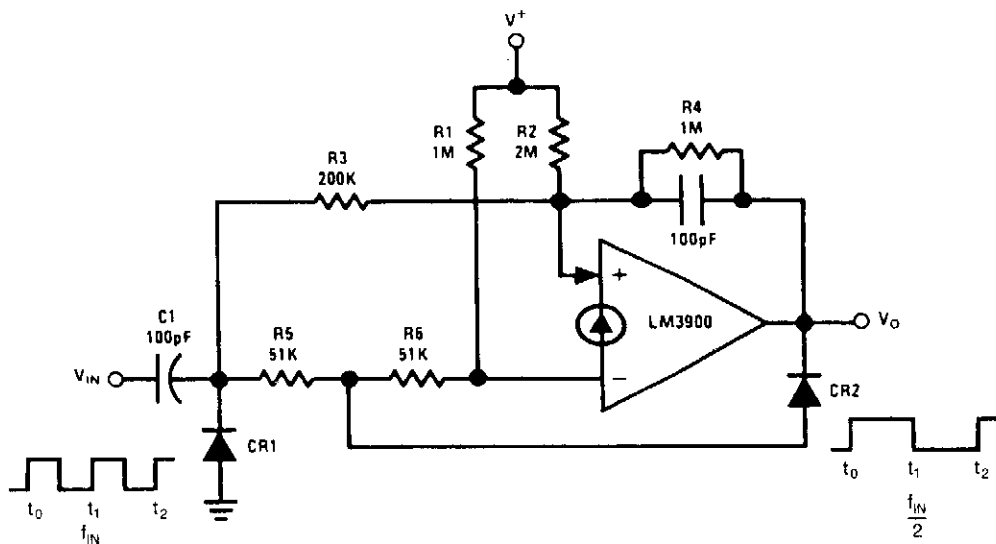

NATIONAL SEMICONDUCTOR

Fig. 34-1

Trigger flip flops are useful to divide an input frequency as each input pulse will cause the output of a trigger flip flop to change state. Due to the absence of a clocking signal input, this is for an asynchronous logic application. A circuit that uses only one amplifier is shown. Steering of the differentiated positive input trigger is provided by diode $CR2$. For a low-output voltage state, $CR2$ shunts the trigger away from the (-) input and resistor $R3$ couples this positive input trigger to the (+) input terminal. This causes the output to switch high. The high-voltage output state now keeps $CR2$ off and the smaller value of $(R_5 + R_6)$ compared with $R3$ causes a larger positive input trigger to be coupled to the (-) input, which causes the output to switch to the low-voltage state.

TWO-AMPLIFIER FLIP FLOP

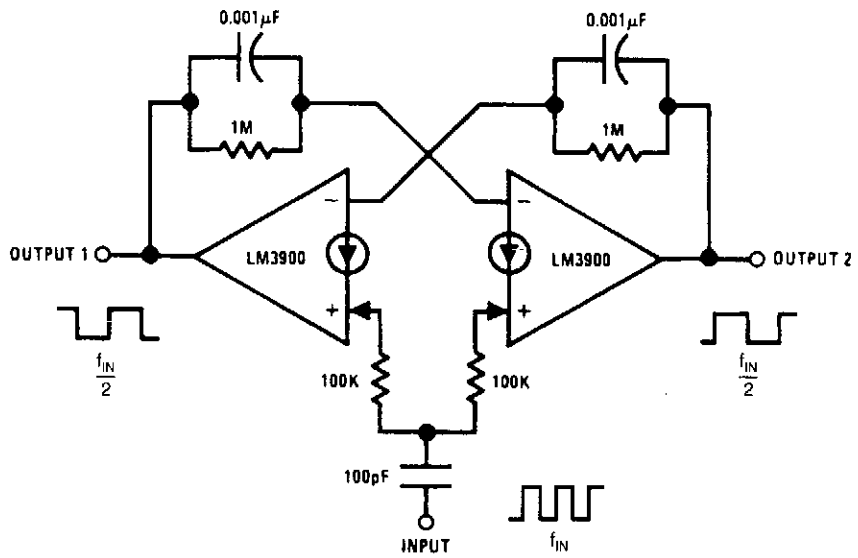

NATIONAL SEMICONDUCTOR

Fig. 34-2

35

Frequency-to-Voltage Converter Circuits

The sources of the following circuits are contained in the Sources section, which begins on page 707. The figure number in the box of each circuit correlates to the entry in the Sources section.

Industrial Frequency-to-Voltage Converter
Frequency-to-Voltage Converter

INDUSTRIAL FREQUENCY-TO-VOLTAGE CONVERTER

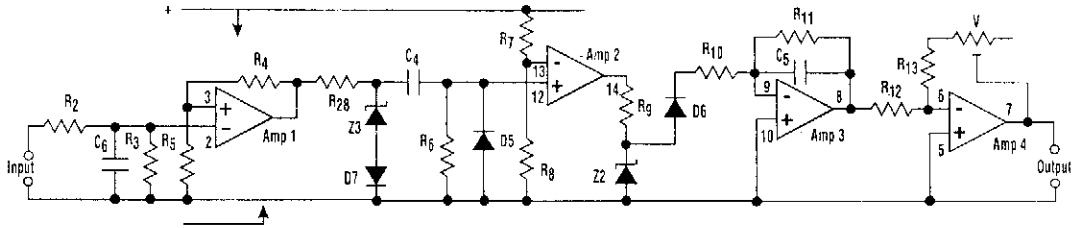

ELECTRONIC DESIGN

Fig. 35-1

Control and process equipment often require the indication of frequency (speed or rate) of linear or rotary mechanical movement. Motion can be detected using various pulse-generating pickups and proximity detectors that output ac or dc pulsed signals.

This industrial converter can serve in a wide variety of applications. The circuit operates around a quad-FET input op amp and is designed to be self-contained or run from a bipolar supply. The input signal of dc pulses or ac waveforms is applied to R2.

Amplifier 1, which acts as a Schmitt trigger, supplies a squarewave output of fixed amplitude to C4. Resistor R3 and capacitor C6 filter out input noise, and R4 and R5 determine the switching levels, and Zener diode Z3 sets the amplitude.

Amplifier 2 gives a fixed-duration pulse on the positive transition of C4, with a time constant set by C4 and R6 and the switching level set by R7 and R8. Resistor R9 and Zener diode Z2 fix the amplitude of the pulses and amplifier 3 integrates them via R10 and C5. Diode D6 blocks negative integration and R11 discharges C5 with a long-time constant.

Hence, the dc output of amplifier 3 is proportional to the frequency applied to the input. Amplifier 4 inverts and buffers the negative output of amplifier 3 and provides amplitude adjustment voltage.

The complete circuit is linear and sufficiently accurate providing that C4 is chosen to give a pulse duration less than the maximum input frequency and that $R11 > R10$.

FREQUENCY-TO-VOLTAGE CONVERTER

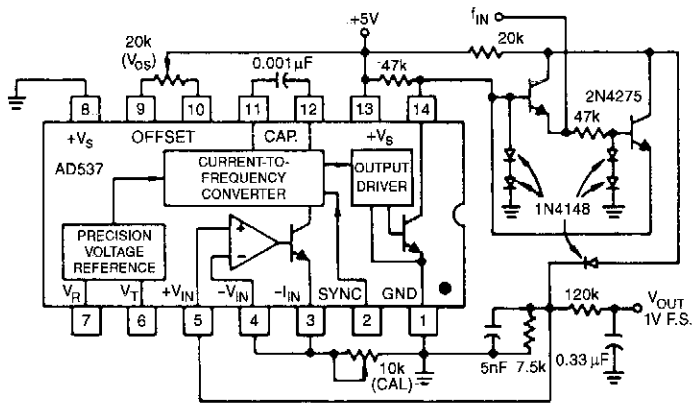

ANALOG DEVICES

Fig. 35-2

The AD537 can also be used to perform frequency-to-voltage conversion. The transistor pair shown here operates as an exclusive-or gate to perform the phase comparison. It locks onto the input frequency within two cycles. The configuration requires only 3 mA for frequencies up to 10 kHz. In most situations, an output buffer will be required to unload the filter. Use 0- to 5-V pulses or square waves with 40- μ s minimum pulsewidth.

36

Function Generator Circuits

The sources of the following circuits are contained in the Sources section, which begins on page 707. The figure number in the box of each circuit correlates to the entry in the Sources section.

Function Generator
Sweep/Function Generator
Simple Function Generator
Accurate, Stable Function Generator
Wide-Range Function Generator

FUNCTION GENERATOR

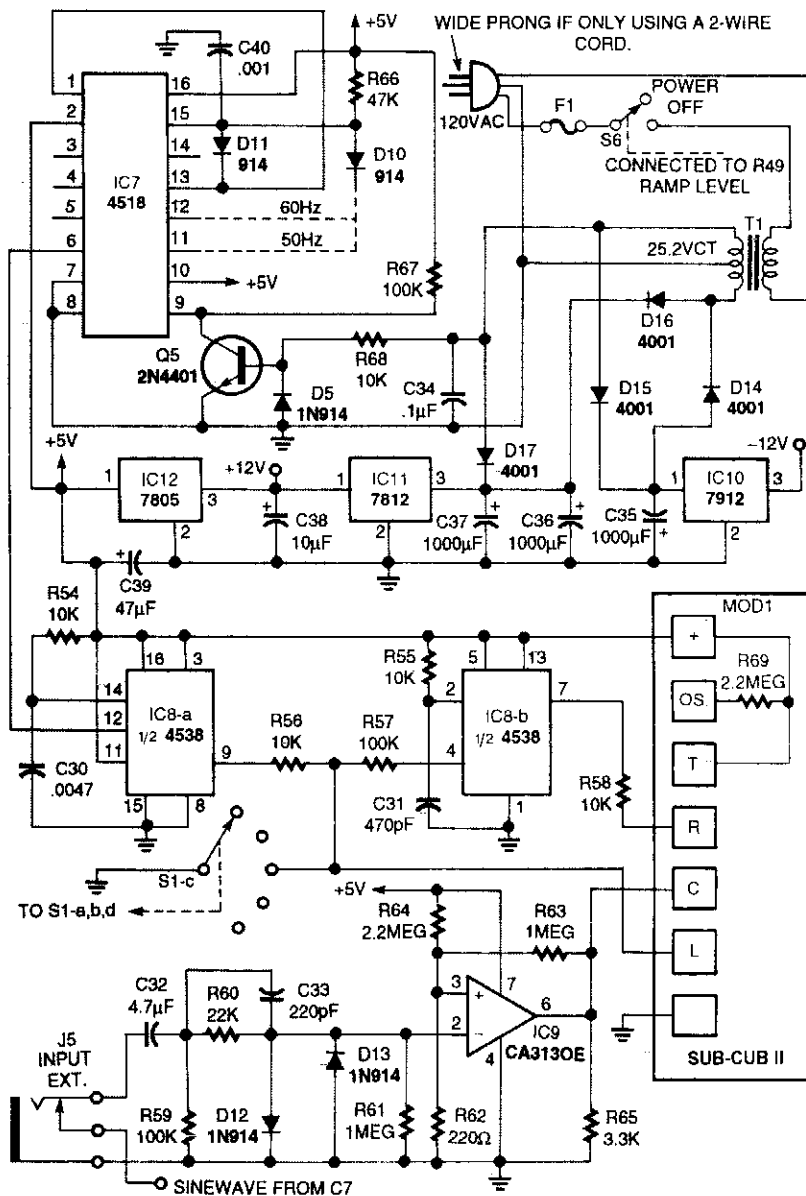

THE COUNTER MODULE (MOD1) has a 0.35-inch high, six-digit liquid crystal display. Pulses at 1-second intervals are derived from the AC power line which has a typical accuracy of 99.99 %.

ELECTRONICS NOW

Fig. 36-1

These three circuits make up an audio frequency function generator and can be individually used for custom applications.

FUNCTION GENERATOR (Cont.)

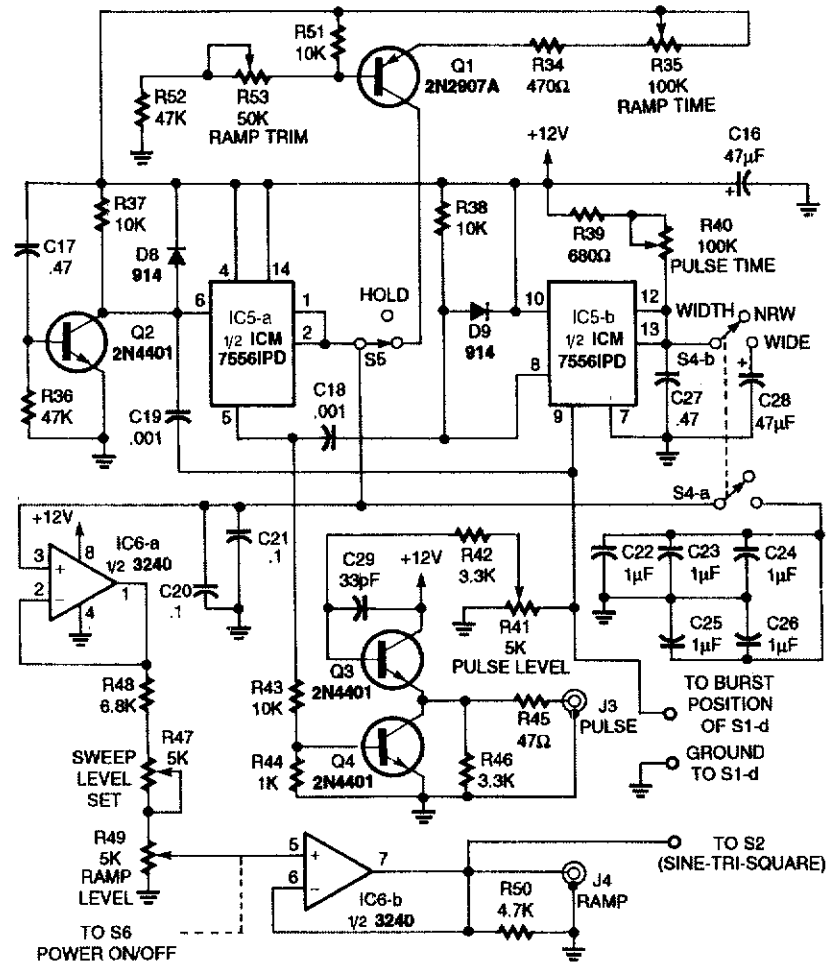

A DUAL CMOS TIMER'S (IC5) output triggers another timer's input. Once Q2 starts IC5-a on initial power-up, the circuit continues to oscillate.

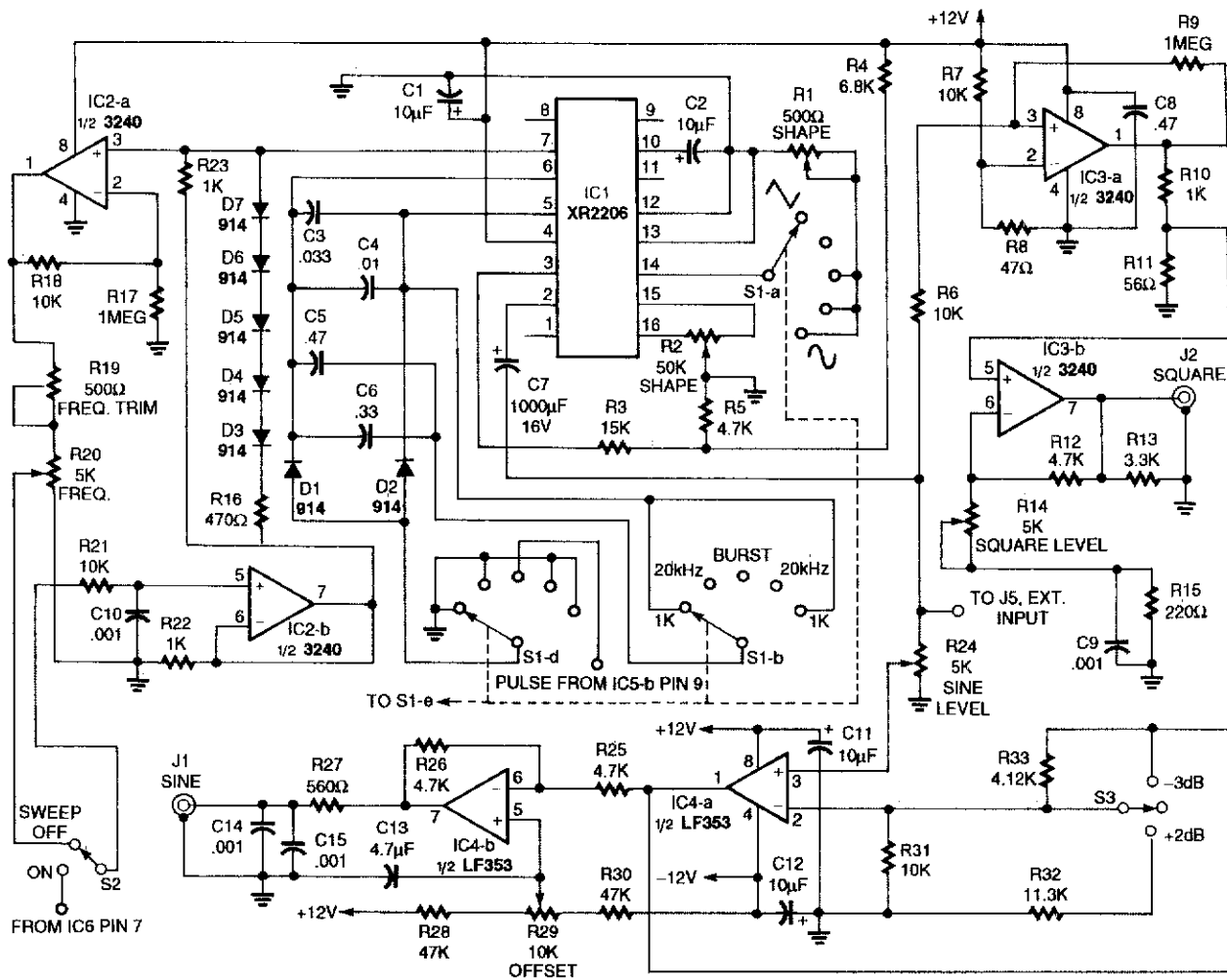

AN XR 2206 FUNCTION-GENERATOR CHIP provides a triangle output at pin 2 when S1-a is open.

SWEEP/FUNCTION GENERATOR

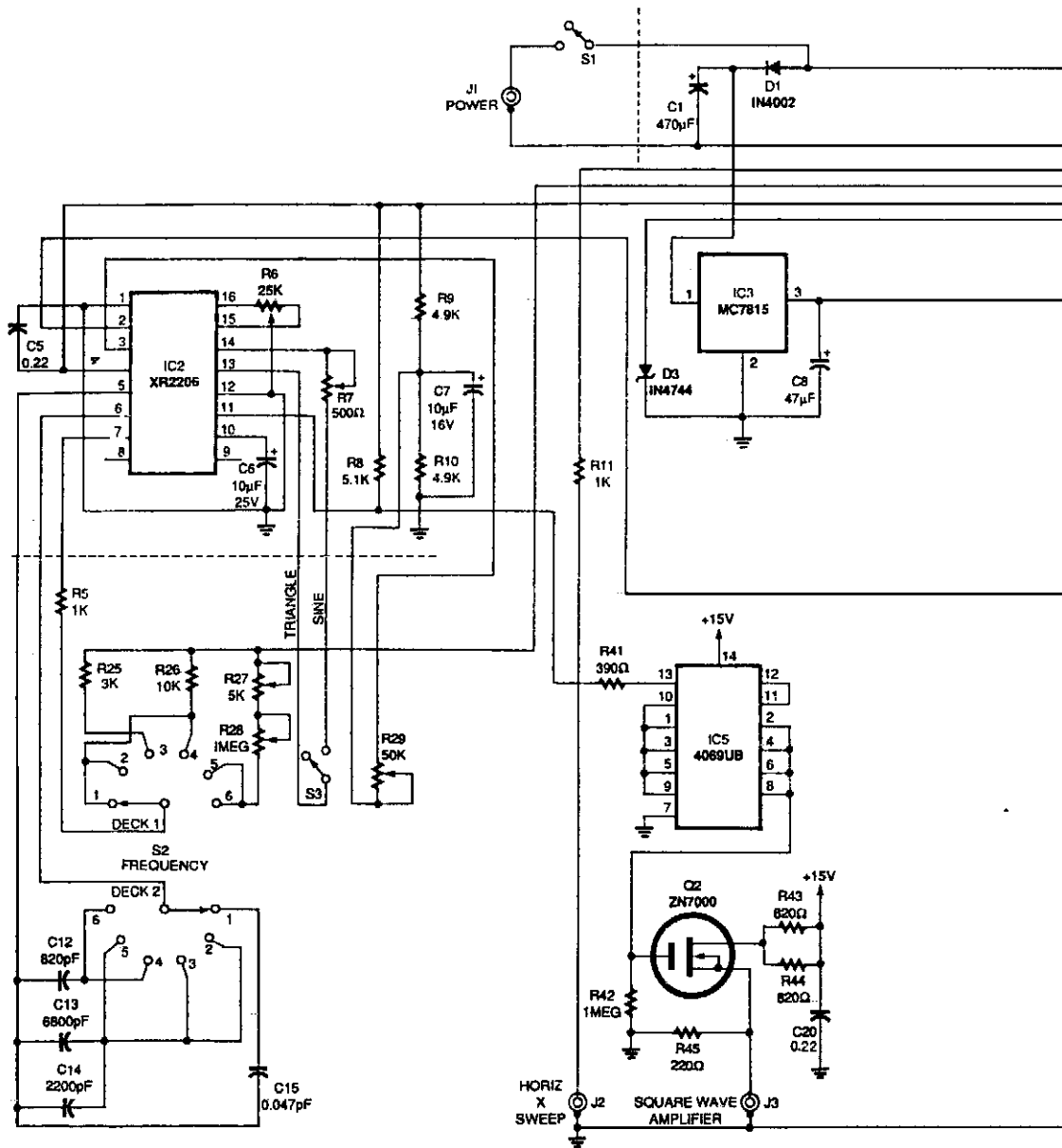

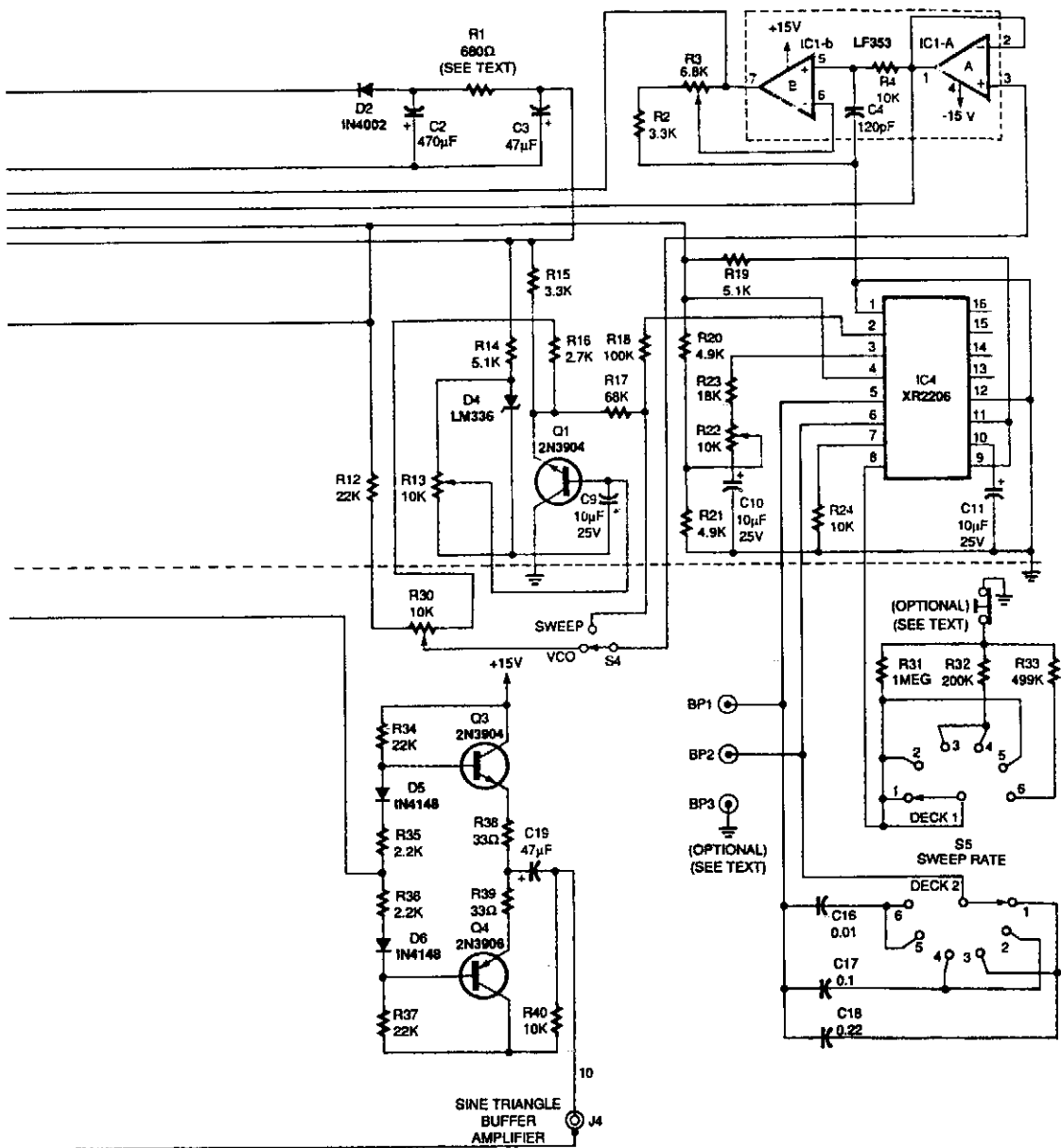

Fig. 36-2

SWEEP/FUNCTION GENERATOR (Cont.)

TABLE 1
FUNCTION GENERATOR CHARACTERISTICS

Waveform output	Maximum P-to-P	Frequency	Conditions
Sine (1)	5V	10 Hz-100 kHz	1 V@800 kHz
Triangle (1)	8 V	10 Hz- 50 kHz	1 V>500 kHz
Square (2)	5 V		Positive output DC-coupled, ground ref: rise/fall >50 ns
Ramp (3)			Descending, 6 rates
(1) Output level variable from min. to max. (2) Output level not adjustable. (3) X and Y amplitude internally adjustable.			

TABLE 2
SWEEP RANGES OF THE FUNCTION GENERATOR

Switch	Condition	Frequency range
1	Preset	20Hz to >2kHz
2	Preset	<400Hz to >10kHz
3	Preset	<1kHz to >25kHz
4	Preset	5kHz to >100kHz
5*	Resistance tuned	2kHz to 100kHz
	Resistance & VCO tuned	<10Hz to >100kHz
6*	Resistance tuned	<40kHz to >800kHz
	Resistance & VCO tuned	<100Hz to >800kHz
* Ranges show for positions 5 and 6 represent the total tuning range of the function generator and do not imply one continuous sweep.		

Both IC2 and IC4 are Exar XR2206 monolithic function generators; IC4 functions as a ramp generator, and IC2 functions as a generator of sine, triangular, and square waveforms. Dual operational amplifier IC1 produces a scaled, level-shifted ramp output that is capable of deflecting an oscilloscope's horizontal sweep.

Any frequency of interest along the horizontal axis of an oscilloscope that is coupled to this function generator can be measured with an external frequency counter by manually tuning the function generator's VCO instead of sweeping it. The performance characteristics of the sweep/function generator are summarized in the Table.

The generator's sweep rate and frequency can be set by front-panel rotary six-position switches, Sweep Rate Switch S5 and Frequency Switch S2. The VCO control R30 manually tunes the VCO. Table 2 lists the sweep ranges of the function generator. Sweep ranges not covered in ranges 1 to 4 can be set up as required on positions 5 and 6. Selecting the VCO setting on the front panel toggle switch S4 permits tuning any fixed frequency within the total frequency range of the instrument with both frequency switch S2 and VCO control R30.

The sweep rate or duration of the sweep ramp is selected by the rotary six-position Sweep Rate Switch S5. Table 3 lists the sweep rate durations for each of the six positions. Longer periods should be used for lower frequency sweeps.

SWEEP/FUNCTION GENERATOR (Cont.)

TABLE 3
SWEEP RATE OR DURATION

Sweep position	Period (milliseconds)
1	~ 130
2	~ 60
3	~ 30
4	~ 15
5	~ 6
6	~ 3

SIMPLE FUNCTION GENERATOR

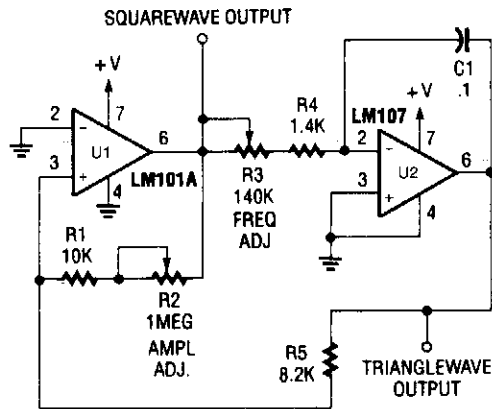

ACCURATE, STABLE FUNCTION GENERATOR

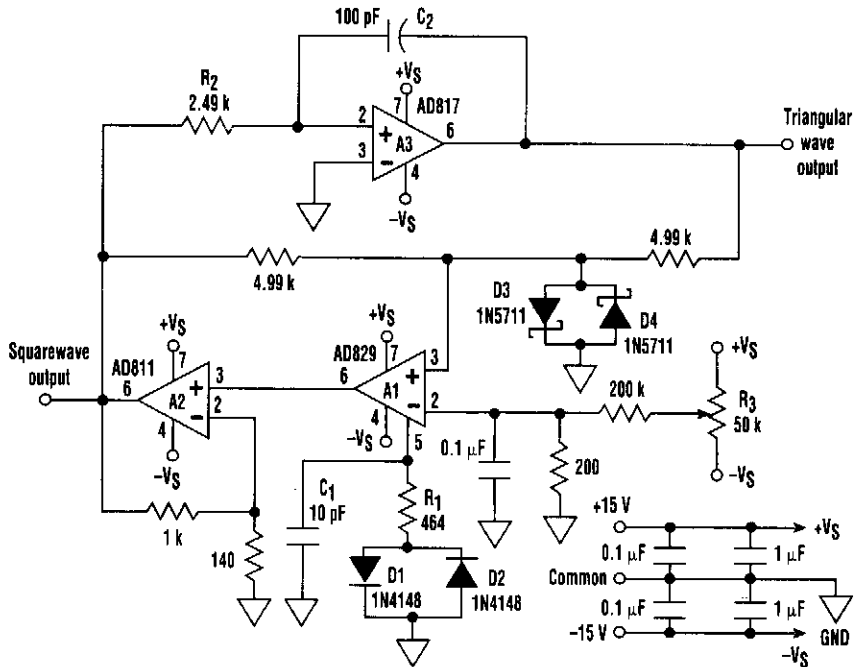

ELECTRONIC DESIGN

Fig. 36-4

Supply-limited oscillators usually are sensitive to temperature and power-supply changes, are never symmetrical, and don't operate at high frequencies because the amplifier's output is saturated when it reaches the supply lines.

The circuit shown, a function generator, can alleviate these problems. Its square-wave output boasts a rapid rise time, quick settling time, and an amplitude that's temperature insensitive. Also, its triangular output waveform features a perfectly constant rate of change throughout its range.

Amplifier A1 together with A2 generates a stable +10 V. This signal, which is integrated using A3, C2, and R2, makes a negative-going ramp. When the peak output of A3 equals -10 V, the output of A1 and A2 change state and the A3's output ramps up. When A3's output equals +10 V, the outputs of A1 and A2 change state again and new cycle starts.

WIDE-RANGE FUNCTION GENERATOR

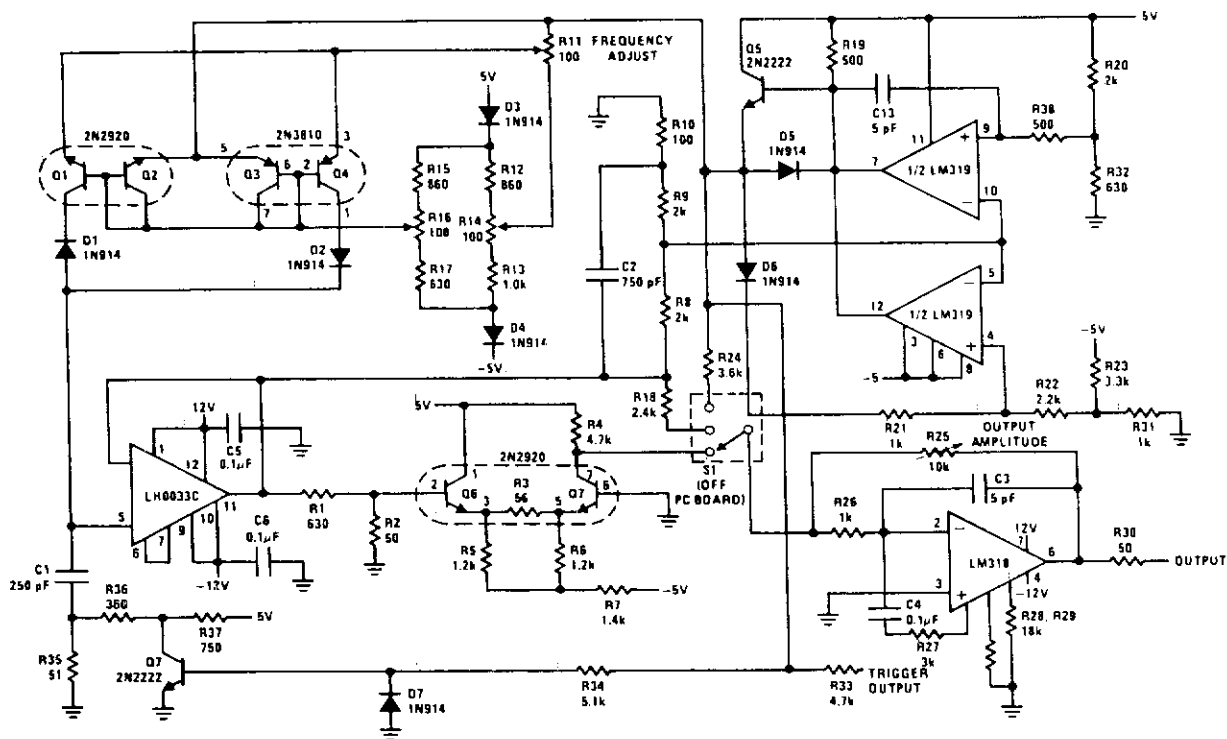

NATIONAL SEMICONDUCTOR

Fig. 36-5

The sine, square, triangle function generator is exceptionally useful. Various IC circuits have been published for generating square and triangle waveforms in an attempt to duplicate the general-purpose function generator. However, these simple circuits are usually limited to about 10 kHz and have no sine-wave output. The function generator shown here provides all three waveforms and operates from below 10 Hz to 1 MHz with usable output to about 2 MHz.

37

Game Circuits

The sources of the following circuits are contained in the Sources section, which begins on page 707. The figure number in the box of each circuit correlates to the entry in the Sources section.

Electronic Craps Game
21 Game
First-Response Monitor I
Z-Dice Game
Three-Input First-Response Monitor
Electronic Coin Toss
Electronic One-Arm Bandit
Digital "First-to-Respond" Box
First-Response Monitor II
Analog First-Response Monitor
Wheel of Fortune

ELECTRONIC CRAPS GAME

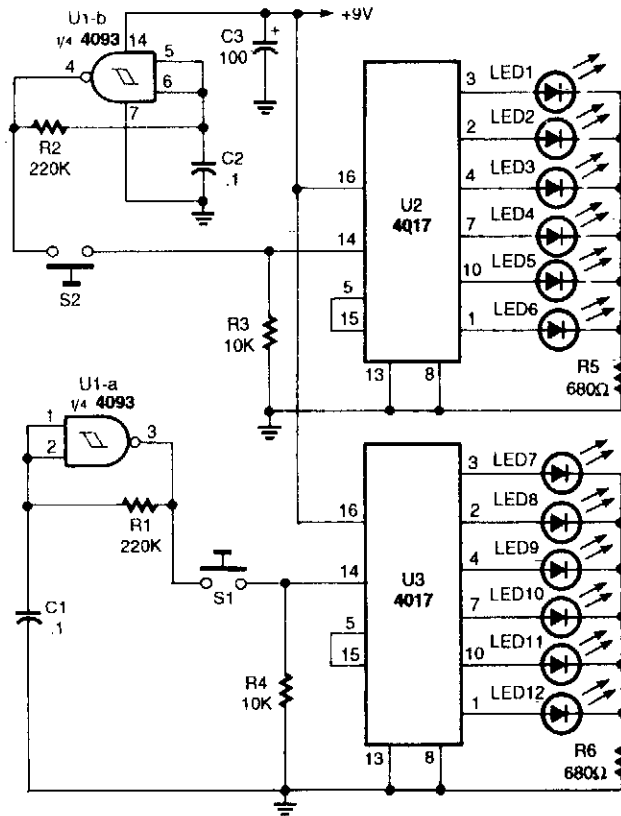

POPULAR ELECTRONICS

Fig. 37-1

Two gates of a 4093 quad, 2-input NAND, Schmitt-trigger CMOS IC are connected in astable-oscillator circuits as clocks. The two 4017 ICs have six LEDs connected to its first six outputs. As the clock pulses enter pin 14 of the 4017s, the ICs count from one to six over and over as long as the clock pulses are present. When S1 and/or S2 are released, one of the LEDs in each circuit will remain on, indicating a number from one to six.

The circuit is set up so that you can roll the dice together by pressing S1 and S2 at the same time, or roll each die one at a time.

21 GAME

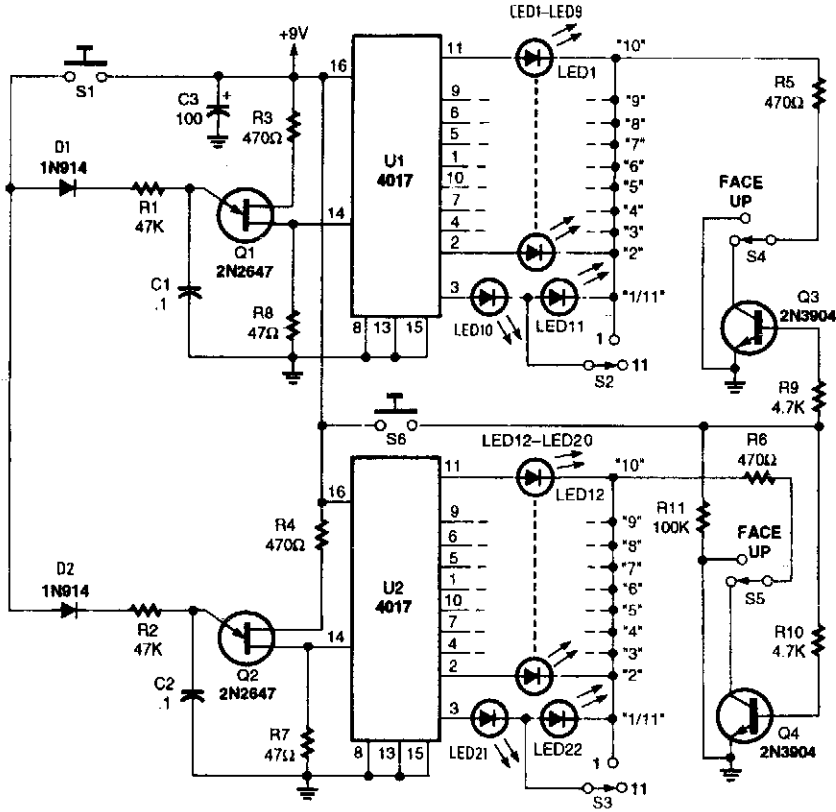

POPULAR ELECTRONICS

Fig. 37-2

Two 2N2647 unijunction transistors serve as the clock generators for the two 4017 ICs. A single "deal" push-button switch, S1, operates both clock generators at the same time. Diodes D1 and D2 isolate the two clock circuits, allowing S1 to operate both.

The 4017 counter/readout circuits are identical in circuitry and operation. As long as clock pulses enter pin 14 of each 4017, the ICs count from 1 to 10 over and over until the clock pulses stop. When S1 is released, the clock pulses stop and one LED from each IC remains on to indicate a card with a number value of 1 (1 or 11) to 10.

The position of switches S2 and S3 determines whether the number 1 ("Ace") output of the 4017s count as an 11 or a 1. Both S2 and S3 can be switched in either position before or after the cards are played.

The cards can be played either face up or face down. When switches S4 and S5 are in the position shown in the figure, the cards are dealt face down. Transistors Q3 and Q4 are turned off in this position and no current can flow through the LEDs. Pressing S6 turns both transistors on, lighting the LEDs.

FIRST-RESPONSE MONITOR I

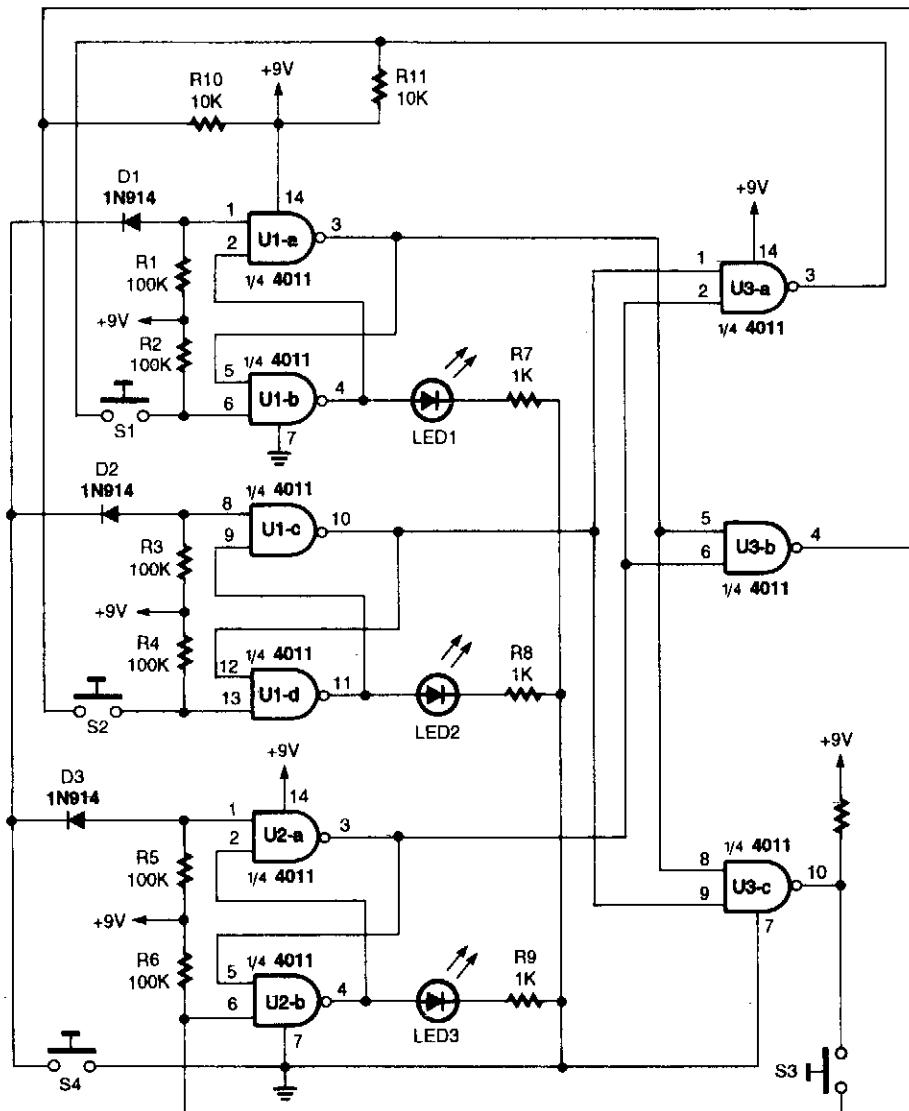

POPULAR ELECTRONICS

Fig. 37-3

Three interlocked flip-flops enable the detection of the first input. S1, S2, and S3 are inputs. Analog switches controlled by logic gates, or other logic circuitry could be substituted for S1, S2, and S3.

Z-DICE GAME

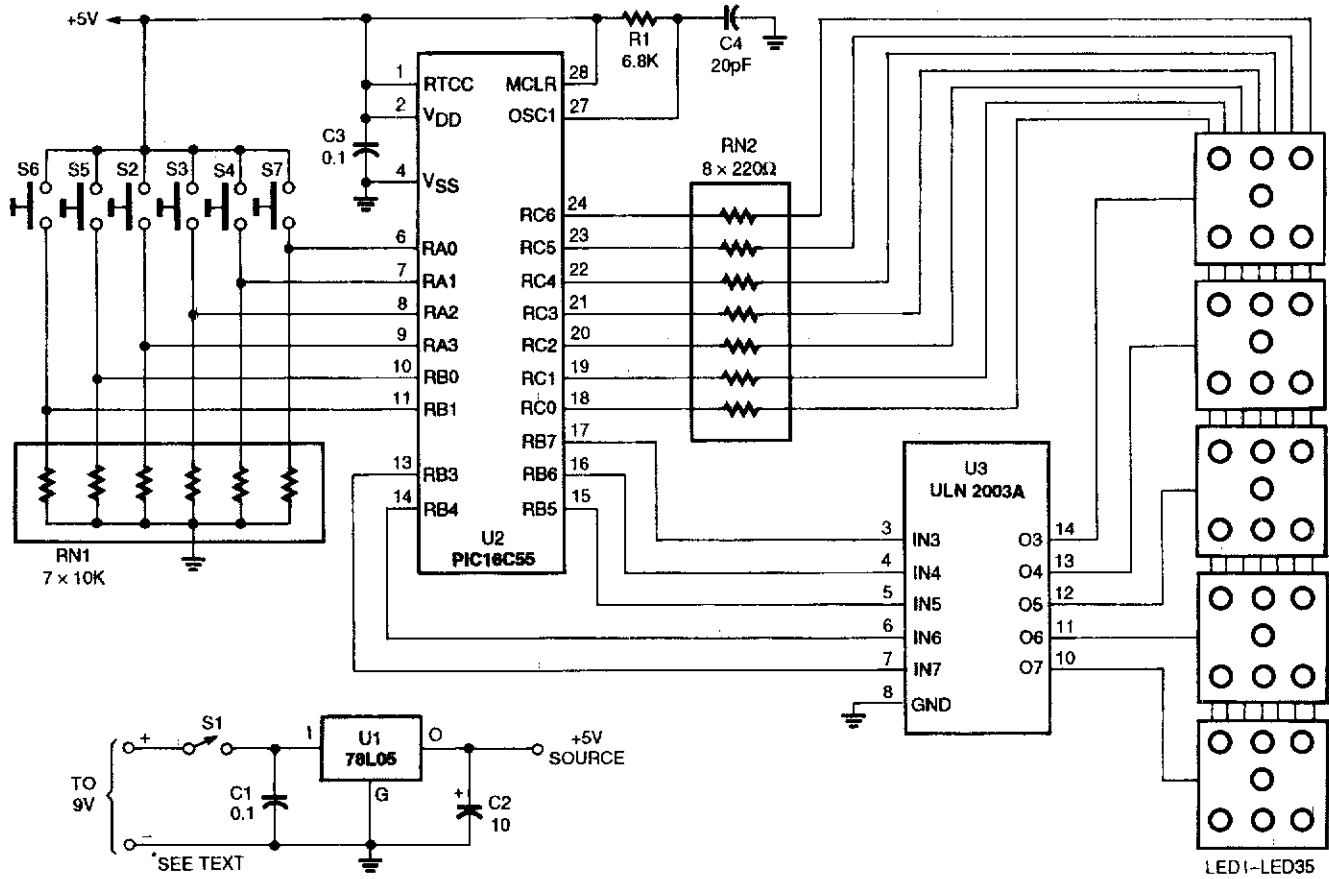

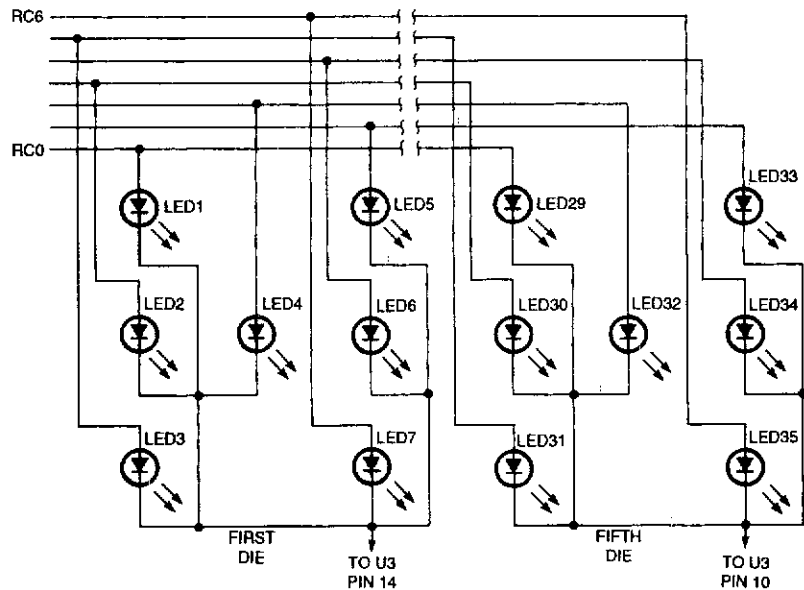
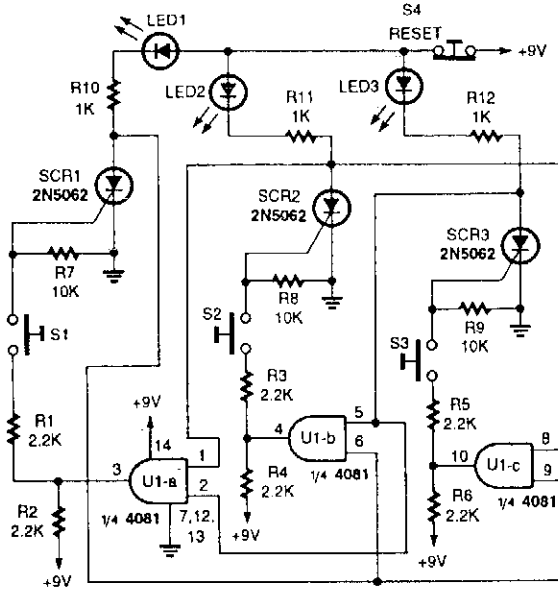

Fig. 37-4

Using a microcontroller (U2) keeps the parts count and the cost of this 5-dice LED display relatively low. Z-dice uses five clusters of seven LEDs to represent the marks or “pips” on five dice. Buttons below each of the LED dice let the player mark a die to be rolled on the next throw. Marked dice show up as dimmed LEDs. Pressing the button to the right of the display rolls the marked dice. If the player changes his or her mind about rolling a particular die before pressing the roll button, he or she can unmark it by pressing its button a second time. If no dice are marked at the time the player presses the roll button, then all of the dice are marked to be rolled. A second press starts them rolling, animating the LEDs of the marked dice for a second or so before displaying the results of the roll. Z-Dice doesn’t count rolls or keep score, so it’s still up to the players to make sure that nobody cheats!

This diagram shows the wiring details of the dice display. For space and simplicity, only the first and last dice are shown. A programmed microcontroller is needed for this circuit. Refer to the original article for software.

THREE-INPUT FIRST-RESPONSE MONITOR



POPULAR ELECTRONICS

Fig. 37-5

ELECTRONIC COIN TOSS

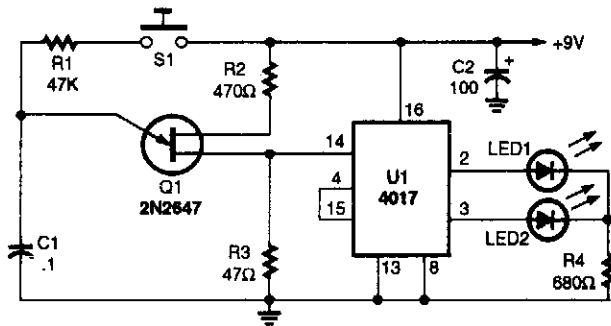

POPULAR ELECTRONICS

Fig. 37-6

Integrated circuit U1 is connected in a two-stage counter circuit that counts “one-two” over and over as long as clock pulses enter pin 14 of the 4017. When the clock pulses stop, one of the LEDs will remain on, indicating the last even or odd count. Designate one LED as “heads” and the other as “tails” and you have an electronic coin flipper.

ELECTRONIC ONE-ARM BANDIT

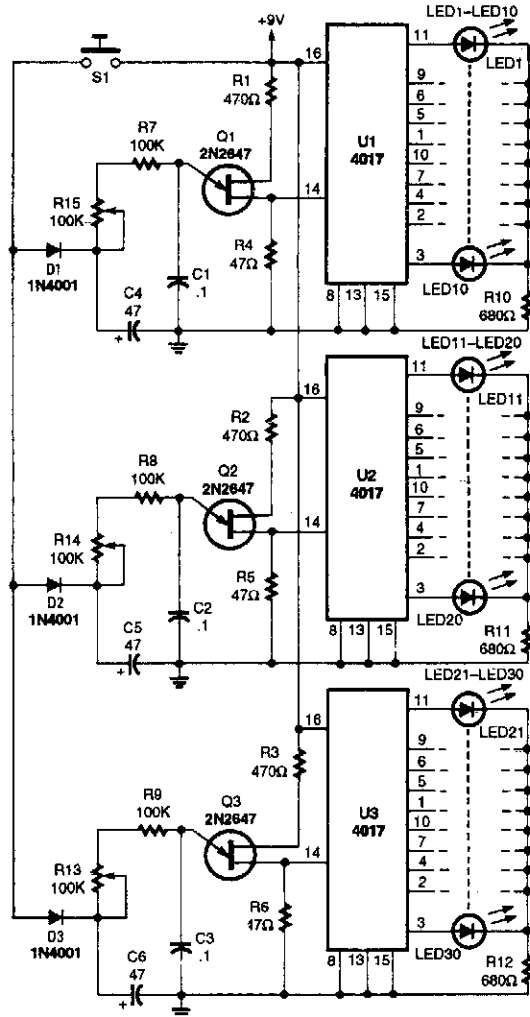

POPULAR ELECTRONICS

Fig. 37-7

The one-arm bandit circuit is made up of three clock circuits and three counter/readout circuits. A single roll switch, S1, turns on all three clocks at the same time. When S1 is closed, capacitors C4, C5, and C6 are charged through D31, D32, and D33 to about 8 V. After S1 is released, the three clocks run, taking energy from the three charged capacitors. As the capacitors discharge, the three clocks begin to slow down, producing the effect of the drums in a mechanical bandit slowing to a stop.

The 4017's 10-output LEDs can be numbered or designated as apples, cherries, bells, wild cards, or anything you like to make the game more interesting. Additional logic circuitry can be added to the 4017 outputs to sound an alert or turn on a light when any three numbers or output items match.

Three potentiometers, R12, R13, and R14, can be varied for each roll to change the clock's frequency and the roll rate.

DIGITAL "FIRST-TO-RESPOND" BOX

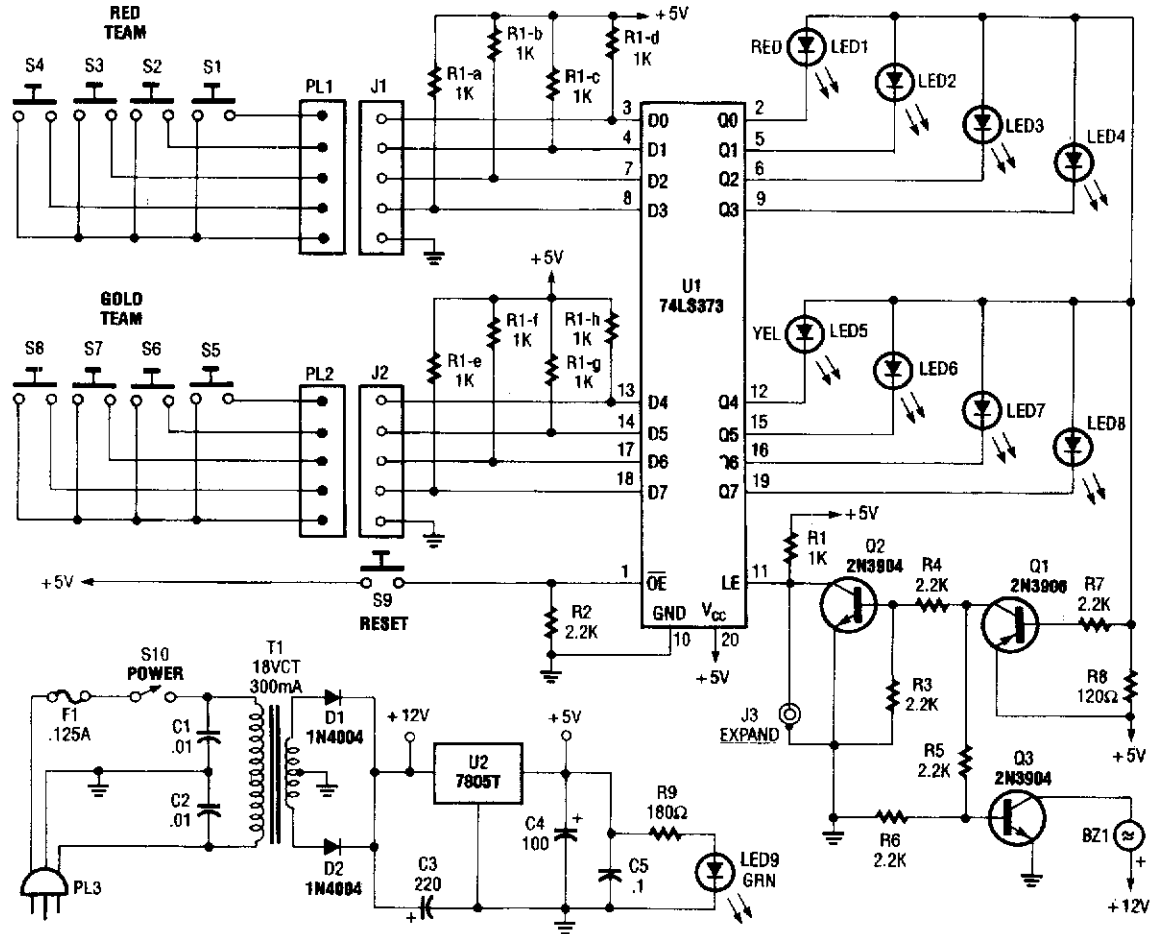

POPULAR ELECTRONICS

Fig. 37-8

This device is useful for quizzes and games to determine first response. U1 is an octal D type latch IC, an 74LS373.

When a button is pushed, this circuit lights the corresponding LED. Q1 conducts, sounding an alarm (BZ1) connected to driver Q3, and Q1 supplies bias to Q2, disabling the rest of the latches in U1.

FIRST-RESPONSE MONITOR II

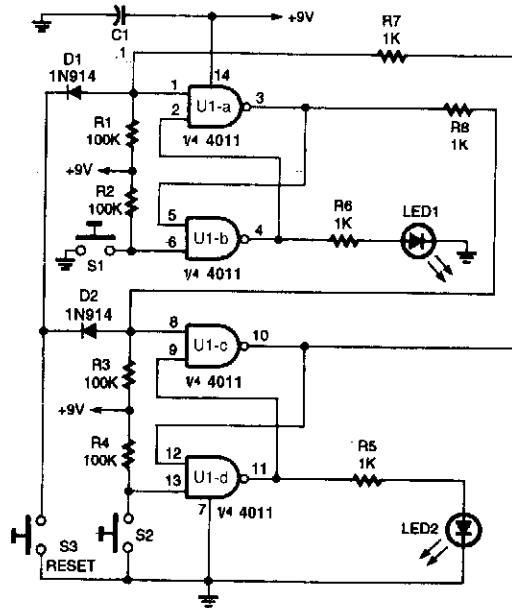

POPULAR ELECTRONICS

Fig. 37-9

Two interlocking flip flops are used to detect the first of two inputs. S1 and S2 are input devices, but a logical-level signal can be substituted.

ANALOG FIRST-RESPONSE MONITOR

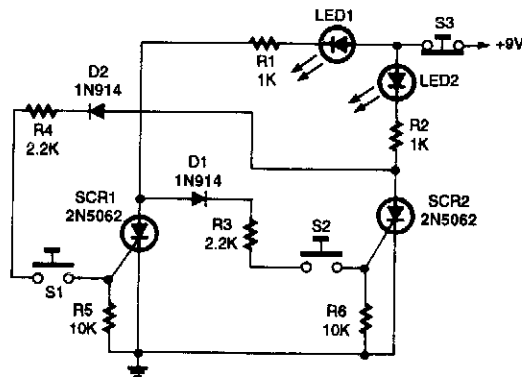

POPULAR ELECTRONICS

Fig. 37-10

The analog first-response monitor is built around a pair of cross-coupled SCRs, each of which receives its gate trigger current from the anode of the other SCR.

WHEEL OF FORTUNE

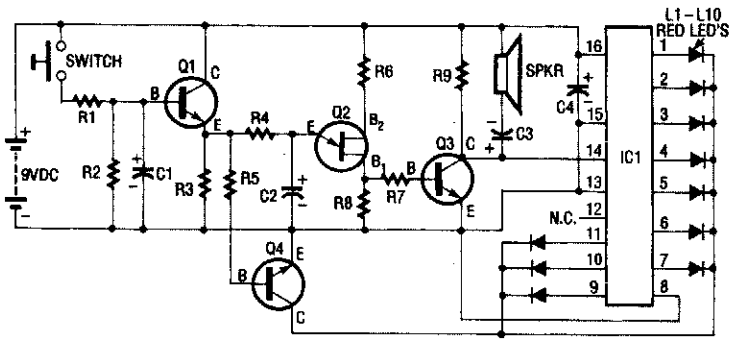

- C1,C3 10 μ F Capacitor
- C2 1 μ F Capacitor
- C4 47 μ F Capacitor
- IC1 MC14017BCP
- L1-L10 Jumbo Red LEDs
- Q1,Q3,Q4 .. 2N3904 Transistor
- Q2 MU10UJT Transistor
- R1,R5 33K Resistor
- R2 2.2 Meg Resistor
- R3 82K Resistor
- R4 47K Resistor
- R6 2.2K Resistor
- R7 390 ohm Resistor
- R8 100 ohm Resistor
- R9 680 ohm Resistor
- S1 Pushbutton Switch

POPULAR ELECTRONICS

Fig. 37-11

The oscillation of Q2 is amplified by Q3 and fed to Johnson counter IC1. The output of IC1 drives the LEDs in sequence to give the impression of a spinning red ball.

38

Humidity Sensor Circuits

The sources of the following circuits are contained in the Sources section, which begins on page 707. The figure number in the box of each circuit correlates to the entry in the Sources section.

Humidity Monitor
Digital Relative Humidity Gauge

HUMIDITY MONITOR

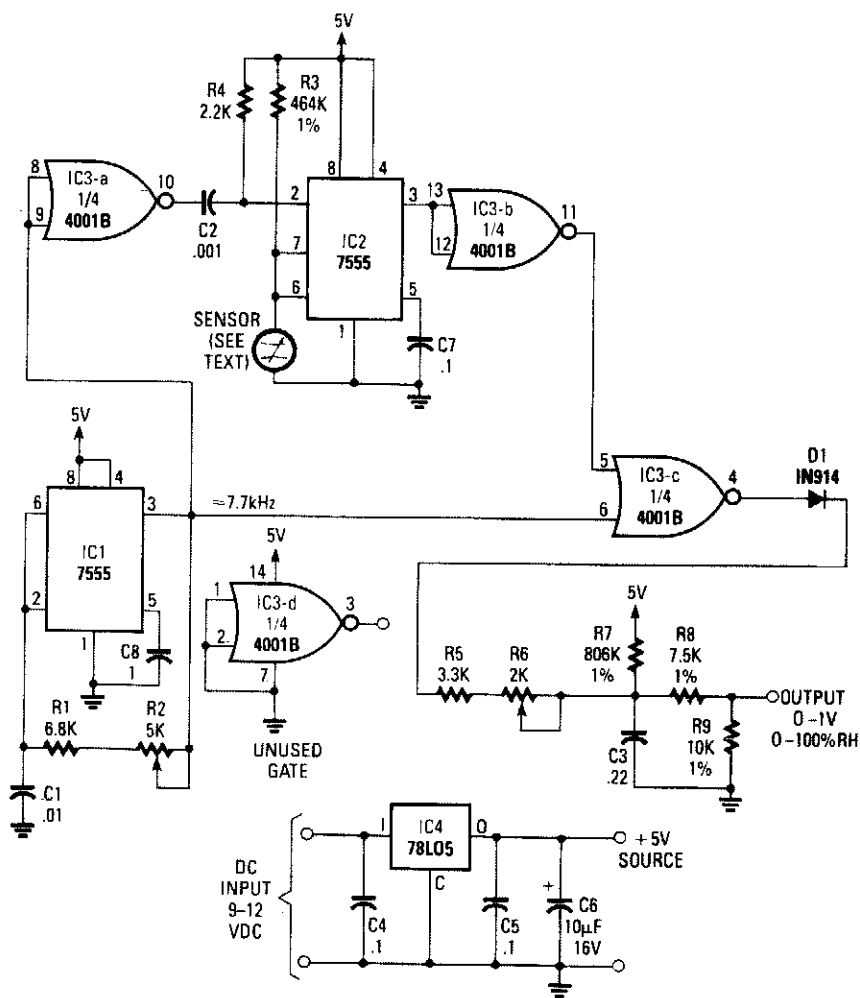

RADIO-ELECTRONICS

Fig. 38-1

This circuit uses a Phillips capacitive humidity sensor that has a ΔC variation of 45 pF over 0 to 100 pF RH. IC2 is an oscillator whose frequency is determined by the RH sensor. It is compared to fixed oscillator, and the difference frequency is taken by IC3C and rectified, outputting a 0- to 1-V signal for RH between 0 and 100%.

DIGITAL RELATIVE HUMIDITY GAUGE

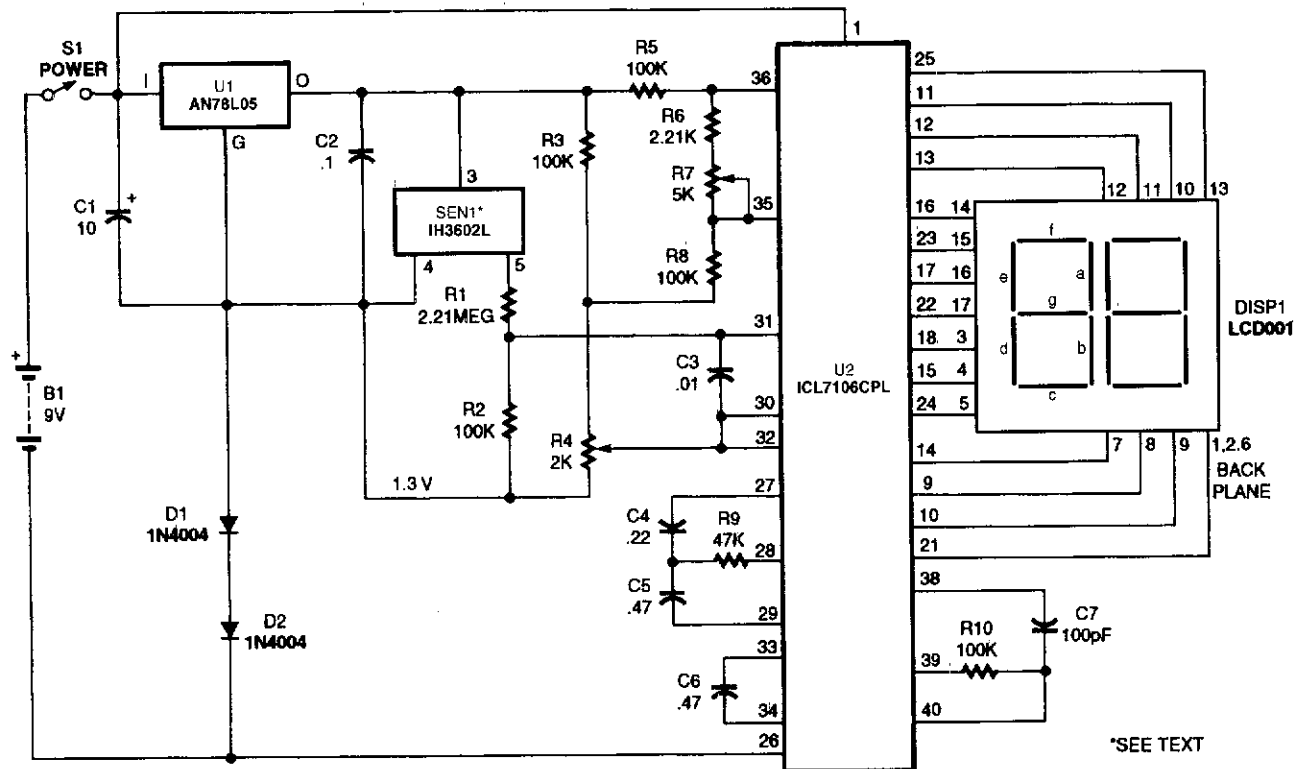

Sensor SEN1 outputs a dc voltage that varies linearly with relative humidity. This dc voltage is fed through R1 and R2 to A/D converter chip U2. Zero set is performed with R4. The LCD display is calibrated with R7 to read 0 to 100 percent.

39

Indicator Circuits

The sources of the following circuits are contained in the Sources section, which begins on page 707. The figure number in the box of each circuit correlates to the entry in the Sources section.

Model Car Derby Winner Indicator
Current Indicator
Receiver Signal-Strength Indicator
LED Output Indicator for 555 Circuits

MODEL CAR DERBY WINNER INDICATOR

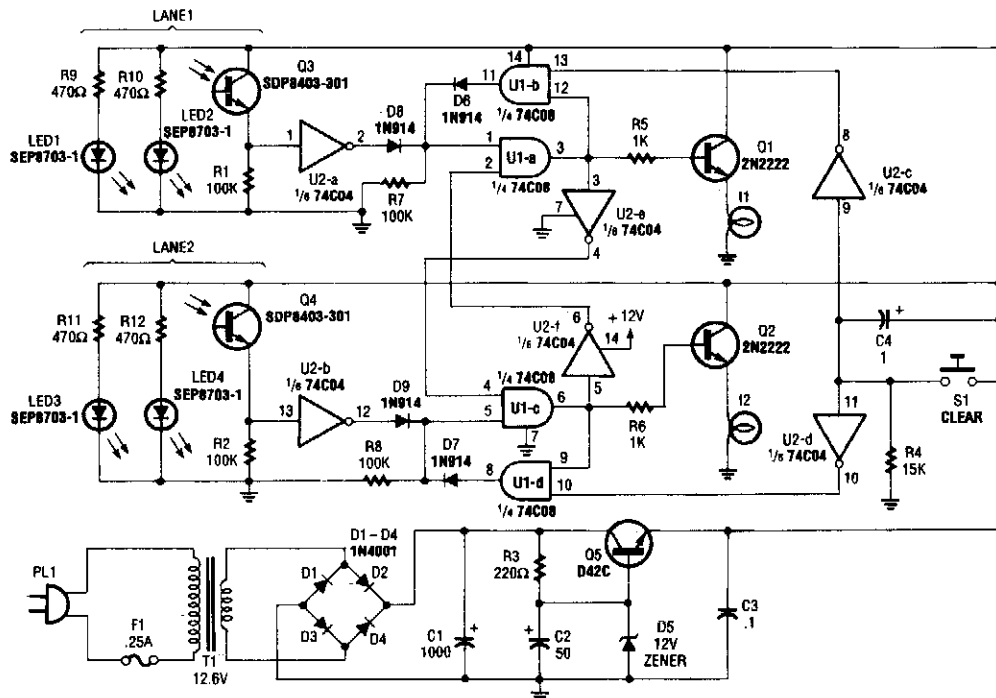

POPULAR ELECTRONICS

Fig. 39-1

This derby-winner indicator uses infrared emitters and sensors to detect a car crossing the finish line. The first car to finish locks out the data from the second car, and the system can be reset by pressing S1.

CURRENT INDICATOR

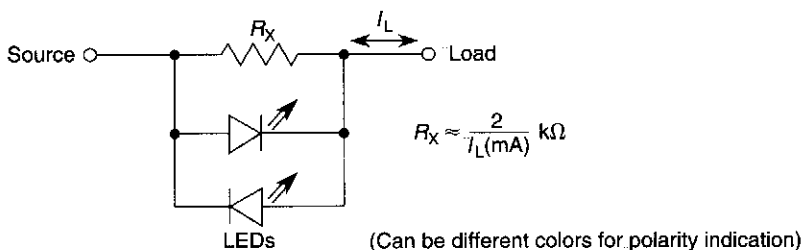

WILLIAM SHEETS

Fig. 39-2

An LED requires 1.5 to 3 V across its terminals to light. This circuit uses a resistor shunt in series with source and load to produce this drop and cause the LED to light. At higher currents (>100 mA) use limiting resistors in series with LEDs to limit current to a safe value.

RECEIVER SIGNAL-STRENGTH INDICATOR

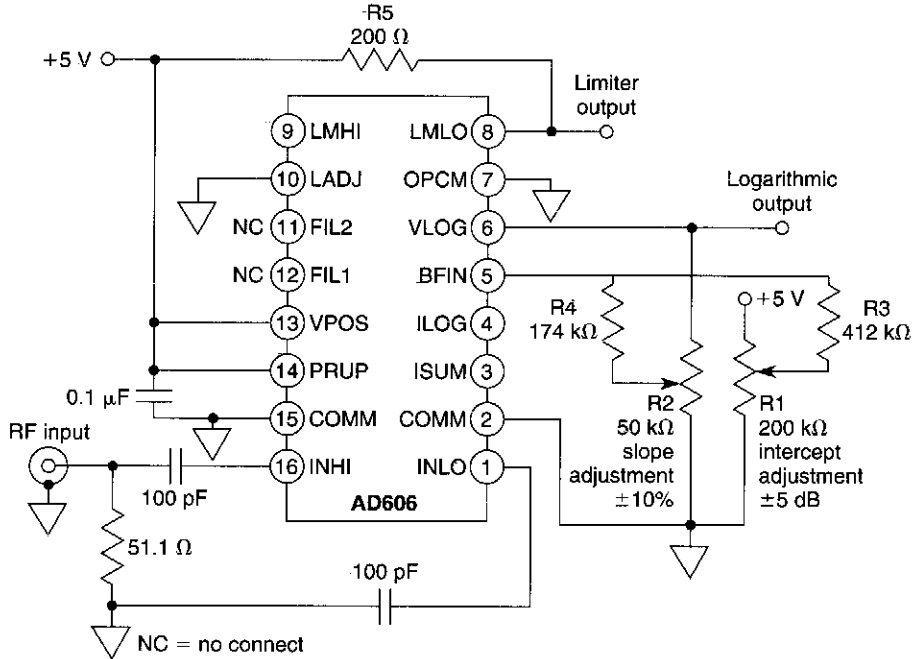

ANALOG DEVICES

Fig. 39-3

Using an AD606 log amplifier, this indicator gives a logarithmic output of +0.3 V at -80-dBm input to +3.5 V at 10-dBm input. Frequency range is to 50 MHz for this IC device.

LED OUTPUT INDICATOR FOR 555 CIRCUITS

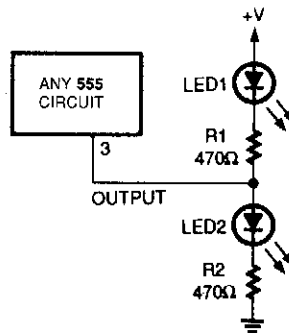

POPULAR ELECTRONICS, JANUARY 1994, P. 73

Fig. 39-4

A pair of LEDs connected as shown here can be used with just about any low-frequency 555 oscillator to give high-/low-output indications. When the output goes high LED2 turns on, and when the output goes low LED1 turns on.

40

Infrared Circuits

The sources of the following circuits are contained in the Sources section, which begins on page 707. The figure number in the box of each circuit correlates to the entry in the Sources section.

Audio-Modulated IR Transmitter
Audible IR Detector
Wireless IR Headphone Transmitter
TV Remote-Control Relay
Single-Tone Infrared Control Transmitter
IR Illuminator for Night-Vision TV Cameras and Scopes
Low-Power Infrared Data-Link Receiver
Infrared Body Heat Detector
IR Detector Circuit
Steady-Tone Infrared Transmitter
FM Infrared Receiver for Audio Reception
General-Purpose IR Receiver
Wireless IR Headphone Receiver
Pulse Frequency-Modulated IR Transmitter
Single-Tone Infrared Receiver
Audible-Output Infrared Receiver

AUDIO-MODULATED IR TRANSMITTER

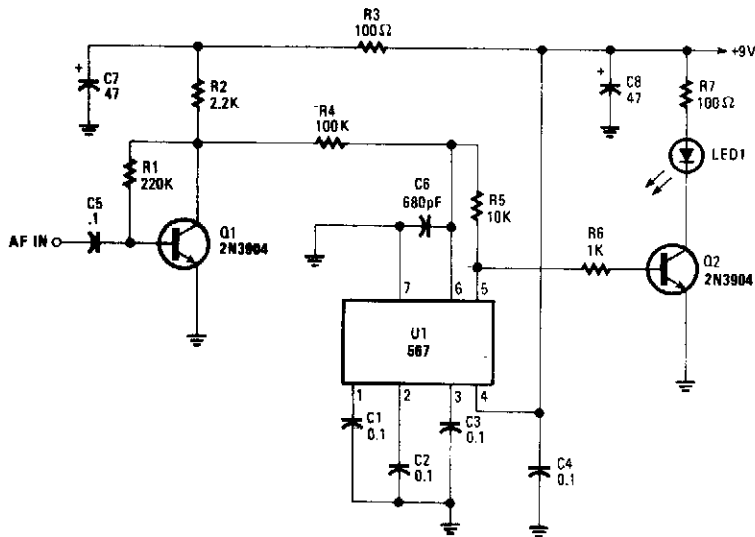

POPULAR ELECTRONICS

Fig. 40-1

This circuit produces an effect similar to frequency modulation (FM) by varying the voltage at pin 6 of the PLL using an audio signal. The FM IR signal can be picked up by a receiver with an FM detector suitably tuned.

AUDIBLE IR DETECTOR

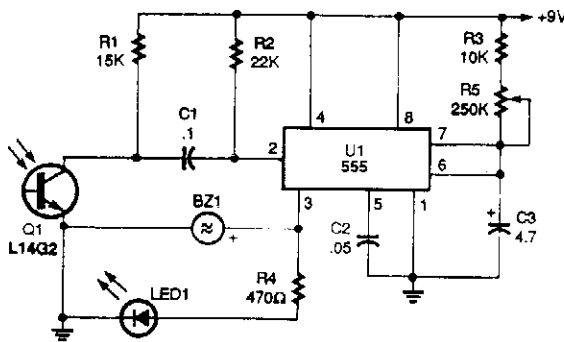

POPULAR ELECTRONICS

Fig. 40-2

An IR-detector circuit offers an audible (as well as a visual) output, and also stretches the on time of the detected pulse to make the output easier to see, as shown.

Photoresistor Q1 detects a remote's IR output pulse and sends a negative-going pulse to the trigger input (pin 2) of the 555 IC, U1. The 555 is connected in a one-shot timer circuit; the output (pin 3) on time is set by the values of C_3 , R_3 , and R_5 . When an input pulse is detected, pin 3 goes high, lighting LED1 and activating the piezo buzzer, BZ1.

For longer output pulses, set R_5 to its maximum resistance value. To lengthen the circuit's on-time range, increase the value of C_3 , and to shorten the on-time range lower the value of C_3 .

WIRELESS IR HEADPHONE TRANSMITTER

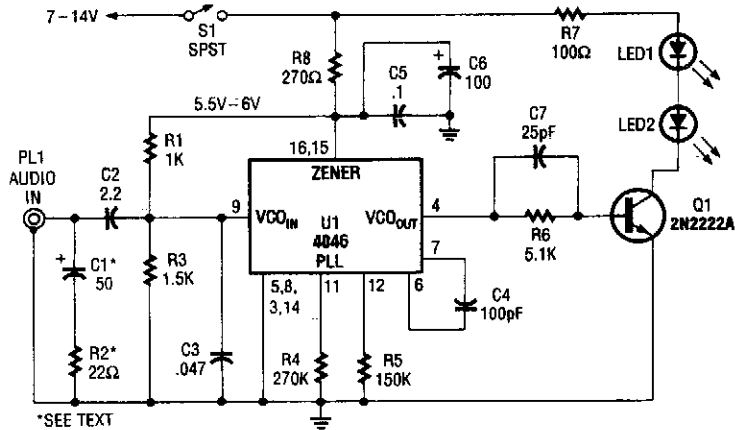

POPULAR ELECTRONICS

Fig. 40-3

Audio input from PL1 frequency modulates the VCO section of a 4046 PLL chip. The VCO output drives Q1, a switching transistor. Q1 drives two IR LEDs. The signal produced is around 100 kHz, FM carrier VCO sensitivity is around 7.5 kHz/V.

TV REMOTE-CONTROL RELAY

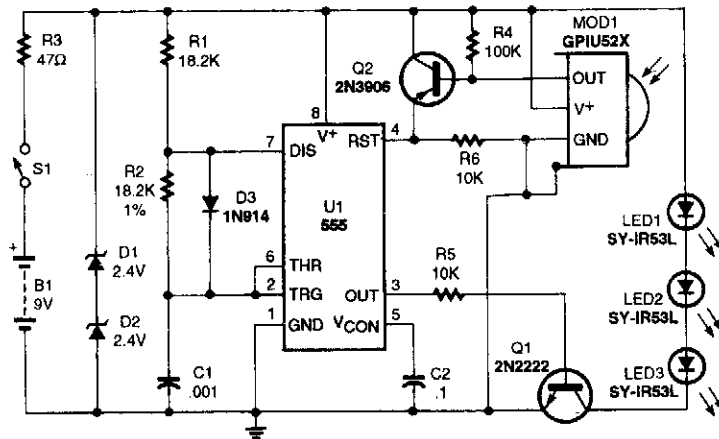

POPULAR ELECTRONICS

Fig. 40-4

This circuit functions as an IR "repeater" to extend the range of your TV remote control. MOD1 is a P/N GP1U52X IR detector and the receiver is available as Radio Shack P/N 276-137.

SINGLE-TONE INFRARED CONTROL TRANSMITTER

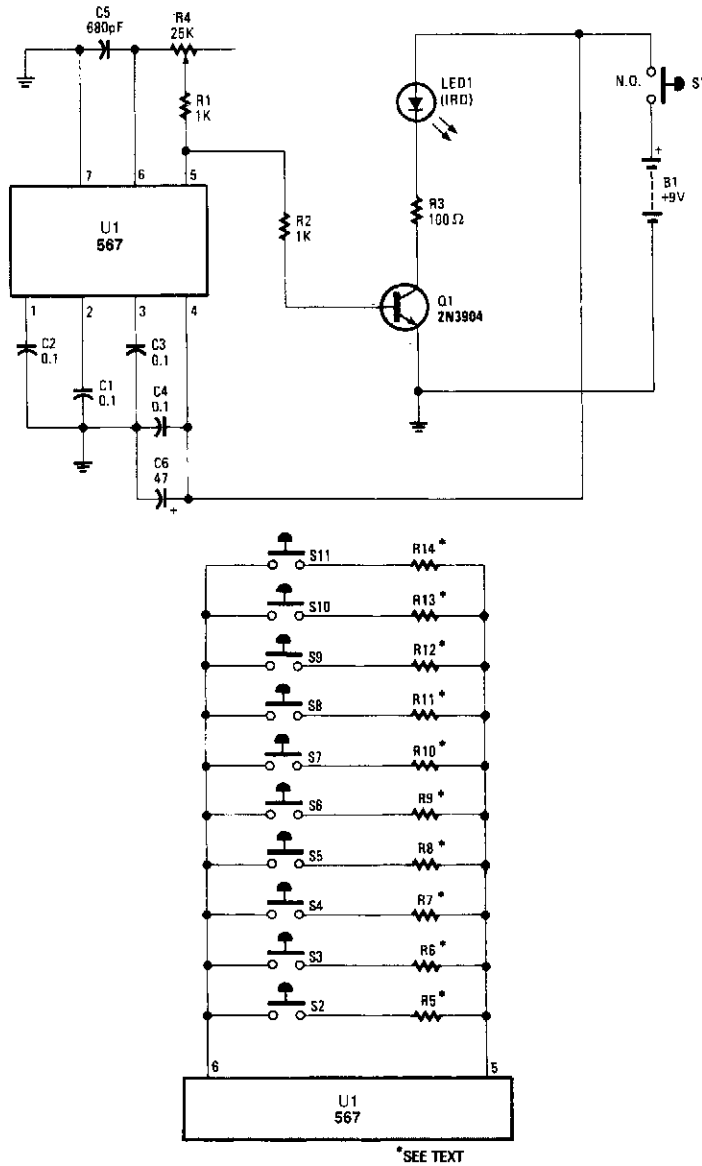

A modulated beam of IR light is produced by this transmitter. This circuit can be used for on/off controls or tone (CW) communications. The pot can be replaced by several pushbuttons and resistors, as shown for multitone applications.

IR ILLUMINATOR FOR NIGHT-VISION TV CAMERAS AND SCOPES

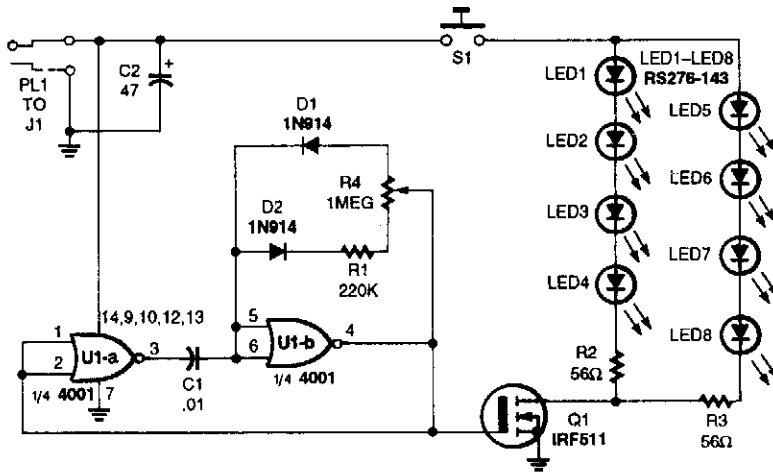

POPULAR ELECTRONICS

Fig. 40-6

This source uses LEDs and an astable oscillator to control the switch, duty-cycle, and effective IR illumination output.

LOW-POWER INFRARED DATA-LINK RECEIVER

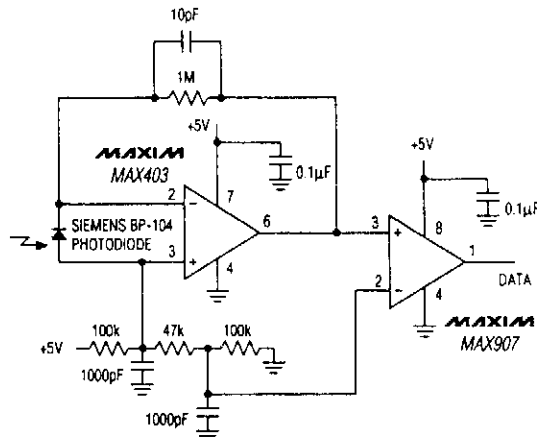

MAXIM

Fig. 40-7

The Maxim MAX403 in this circuit consumes only 1 mA and is capable of speeds over 1 MBPS.

INFRARED BODY-HEAT DETECTOR

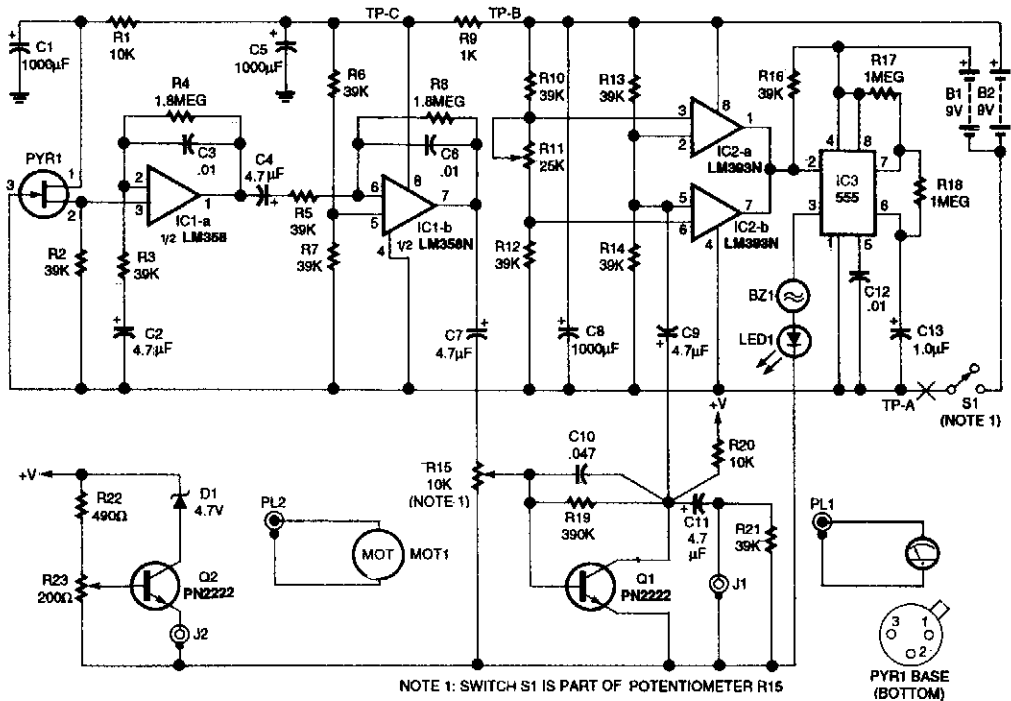

ELECTRONICS NOW

Fig. 40-8

This circuit uses a pyroelectric detector to detect IR emissions in the 6- to 14-micron range. It is useful for security or infrared experiments. PYR1 is a pyroelectric IR detector. The unit should be mounted in a case with an IR lens to focus energy on the detector.

IR DETECTOR CIRCUIT

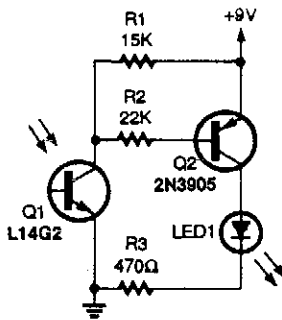

The circuit uses an IR phototransistor, Q1, to detect a remote control's IR output signal. A PNP transistor, Q2, then amplifies Q1's output and lights LED1. That indicates that an infrared signal has been detected by the phototransistor, or in other words, that your remote control works.

POPULAR ELECTRONICS

Fig. 40-9

STEADY-TONE INFRARED TRANSMITTER

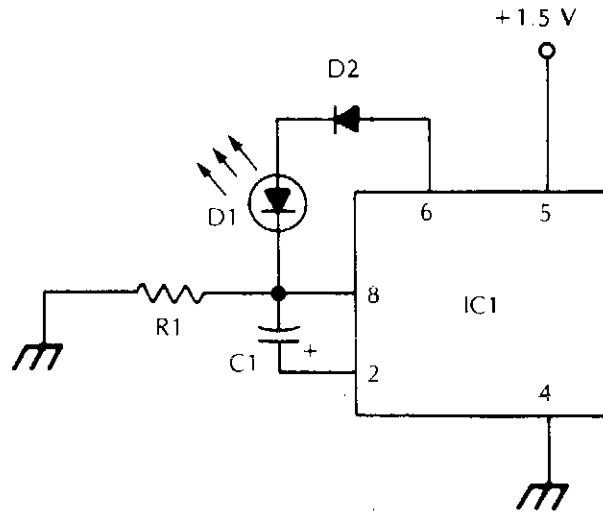

- IC1 LM3909 LED flasher/oscillator IC
- D1 infrared LED
- D2 diode (1N4148, 1N914, or similar)
- C1 1 μ F 5 V electrolytic capacitor
- R1 1.5 k Ω 1/4 W 5% resistor

McGRAW-HILL

Fig. 40-10

This oscillator pulses an IR LED at about 1000 Hz. It should be useful as a test for lining up IR communications links or setting up fiber-optic cables, etc.

FM INFRARED RECEIVER FOR AUDIO RECEPTION

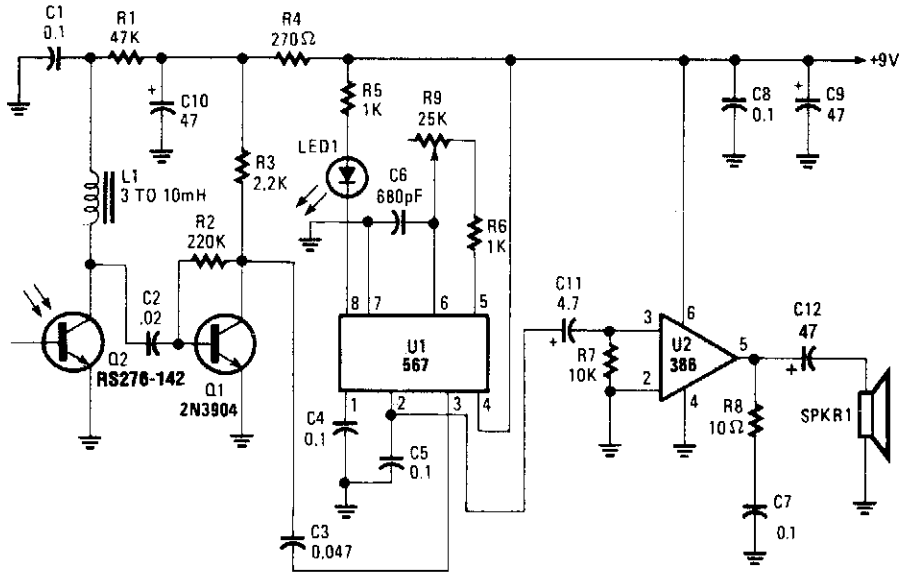

POPULAR ELECTRONICS

Fig. 40-11

Modulated IR energy strikes Q2, a phototransistor. Q1 is a tuned amplifier, and feeds PLL detector U1. U2 is an audio amplifier that drives a speaker.

GENERAL-PURPOSE IR RECEIVER

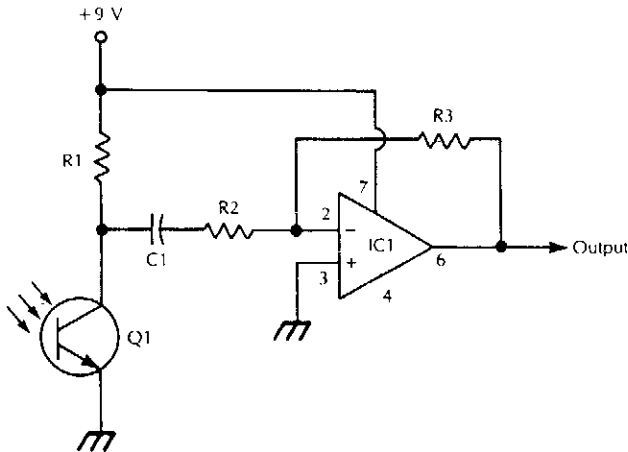

IC1	741 op amp
Q1	infrared phototransistor
C1	0.01 μ F capacitor
R1	100 k Ω 1/4 W 5% resistor
R2	2.2 k Ω 1/4 W 5% resistor
R3	1 M Ω 1/4 W 5% resistor

McGRAW-HILL

Fig. 40-12

Suitable for amplitude-modulated IR beams, this receiver provides an audio signal that corresponds to the modulation envelope. Phototransistor Q1 should be properly mounted and shielded from stray light. This receiver should drive a small earphone directly.

WIRELESS IR HEADPHONE RECEIVER

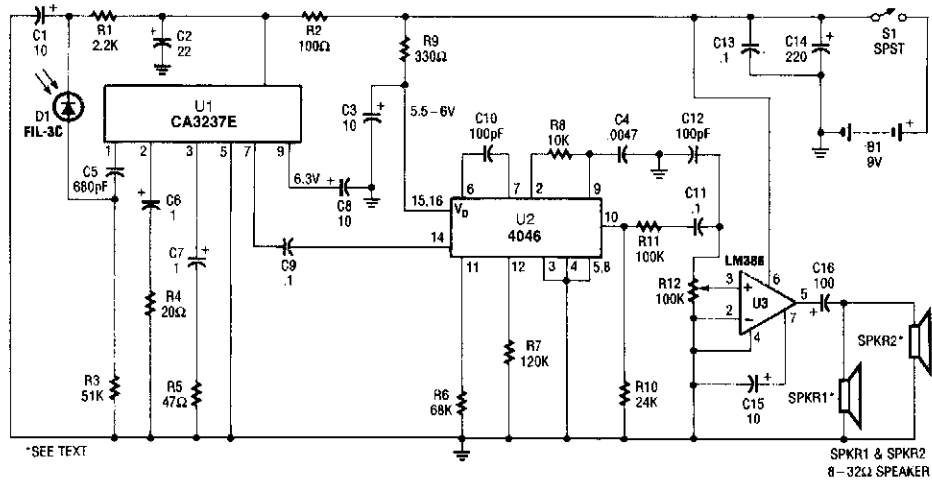

Fig. 40-13

POPULAR ELECTRONICS

A photodiode D1 feeds high gain IR remote control preamp IC, a CA3237E. U2 is a PLL FM detector tuned to around 100 kHz. The detector output is amplified by U3 and it can drive a speaker or a set of headphones.

PULSE FREQUENCY-MODULATED IR TRANSMITTER

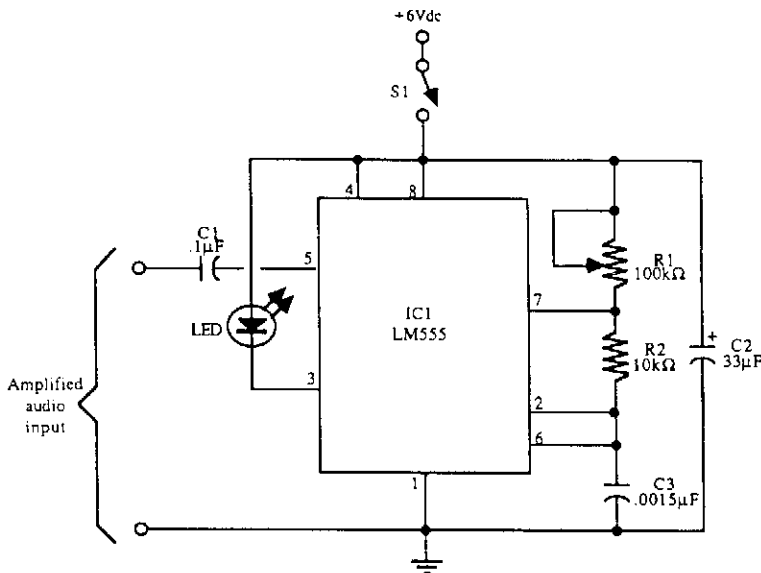
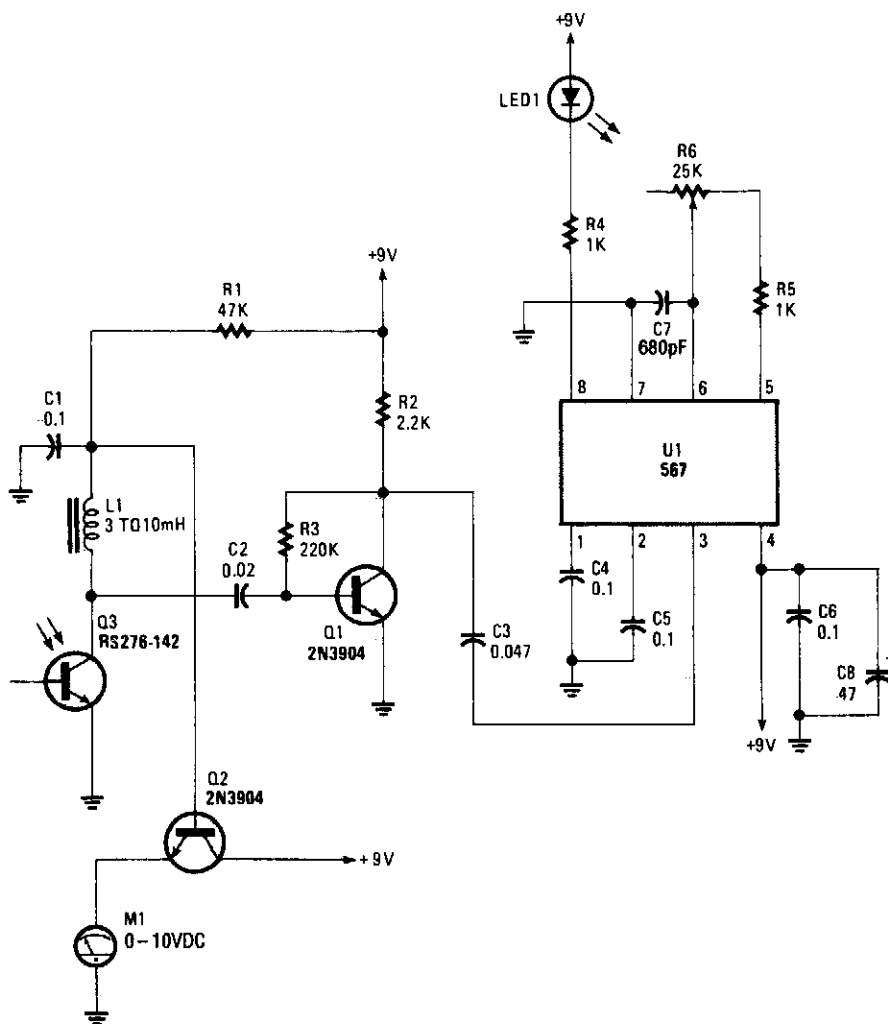

Fig. 40-14

McGRAW-HILL

Schematic diagram for the pulse frequency-modulated LED transmitter. Adjust the frequency by rotating R1. With components shown, the frequency range is between 8 and 48 kHz.

SINGLE-TONE INFRARED RECEIVER



Phototransistor Q3 acts as a sensor that detects modulated IR energy. Q1 is an amplifier and U1 is a tone decoder. LED1 lights on reception of an IR signal with proper tone modulation.

AUDIBLE-OUTPUT INFRARED RECEIVER

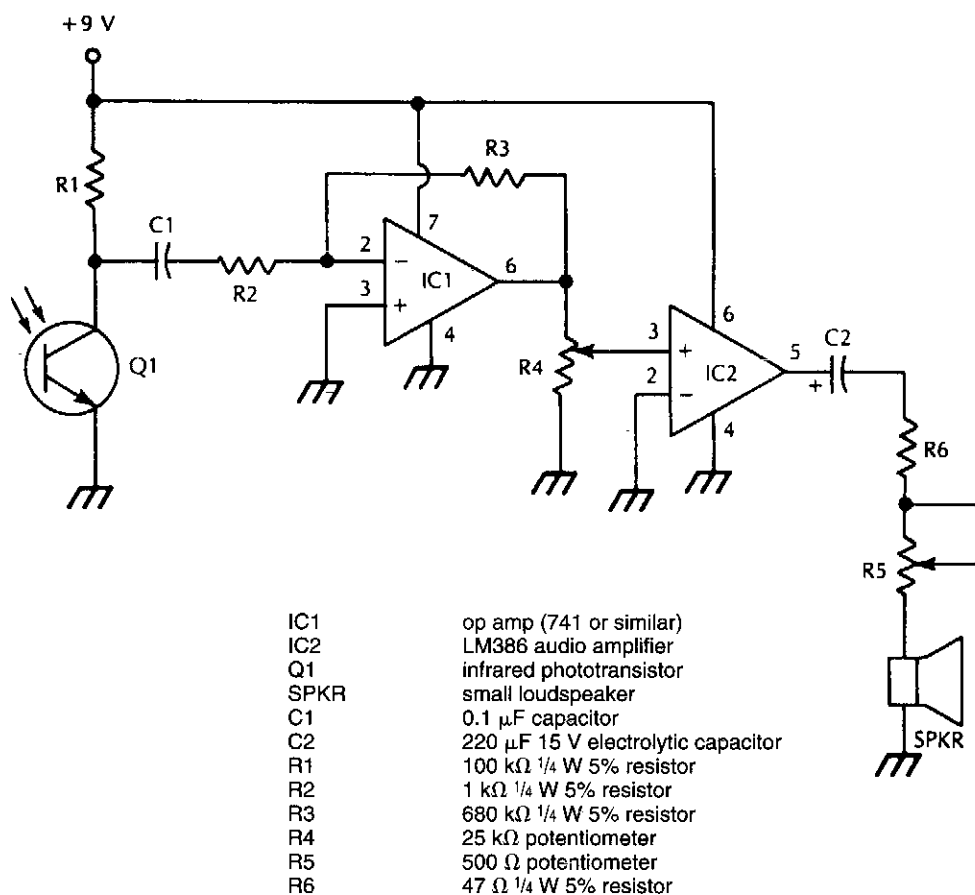

McGRAW-HILL

Fig. 40-16

This receiver is designed to demodulate amplitude-modulated (AM) IR light beams and will drive a loudspeaker. R5 is an auxiliary volume control and it could be omitted. Q1 should be suitably mounted and shielded from stray light pickup.

41

Instrumentation Amplifier Circuits

The sources of the following circuits are contained in the Sources section, which begins on page 707. The figure number in the box of each circuit correlates to the entry in the Sources section.

- ×100 Instrumentation Amplifier
- Instrumentation Amplifier
- Variable-Gain Differential-Input Instrumentation Amplifier
- Programmable Gain Instrumentation Amplifier for Single-Supply Applications
- Differential-Input Instrumentation Amplifier
- High Input-Impedance Instrumentation Amplifier
- ac-Coupled Instrumentation Amplifier
- Low-Noise Instrumentation Amplifier
- Low-Power Instrumentation Amplifier
- Ultra-Low-Noise Single-Supply Instrumentation Amplifier
- Instrumentation Amplifier

×100 INSTRUMENTATION AMPLIFIER

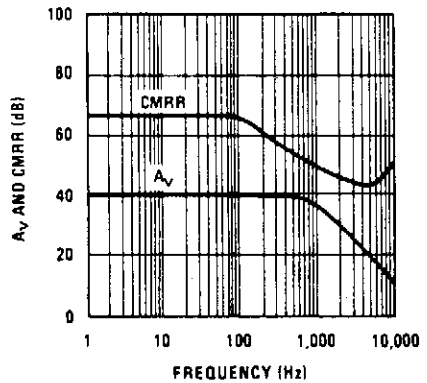
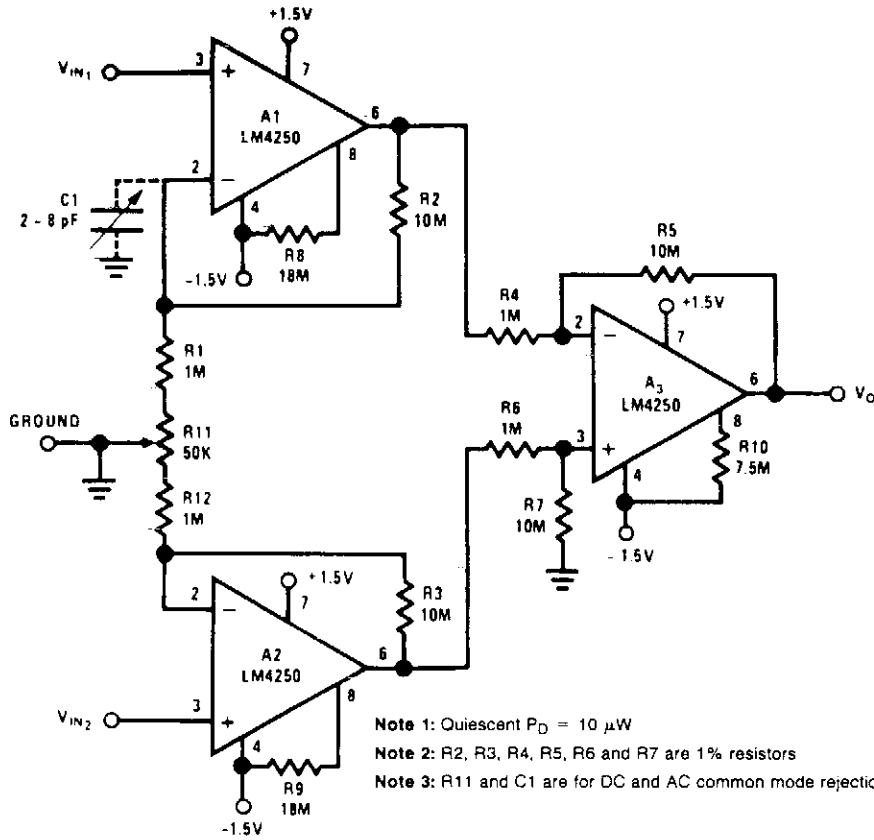

NATIONAL SEMICONDUCTOR

Fig. 41-1

CMRR vs. frequency.

INSTRUMENTATION AMPLIFIER

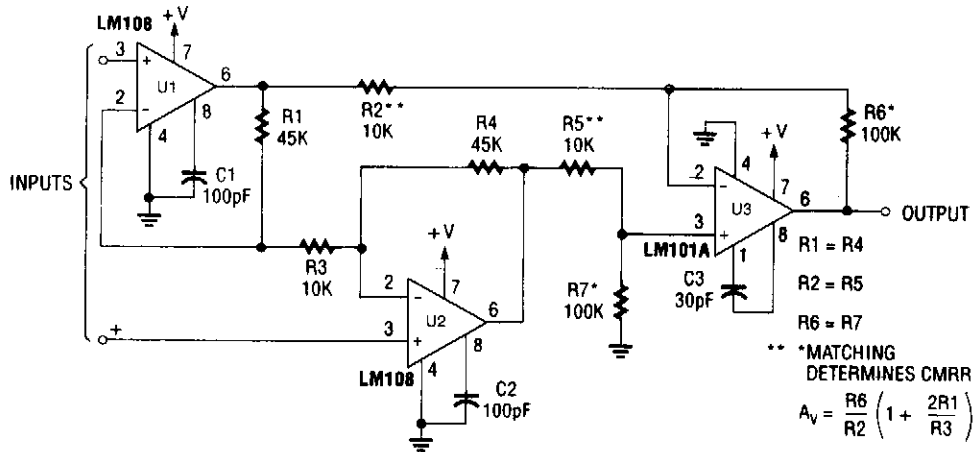

LINEAR TECHNOLOGY

Fig. 41-2

VARIABLE-GAIN DIFFERENTIAL INPUT INSTRUMENTATION AMPLIFIER

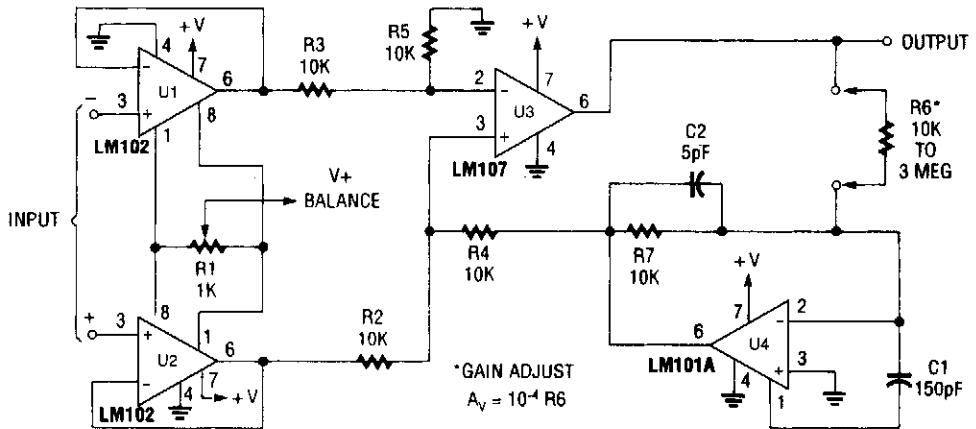

POPULAR ELECTRONICS

Fig. 41-3

PROGRAMMABLE GAIN INSTRUMENTATION AMPLIFIER FOR SINGLE-SUPPLY APPLICATIONS

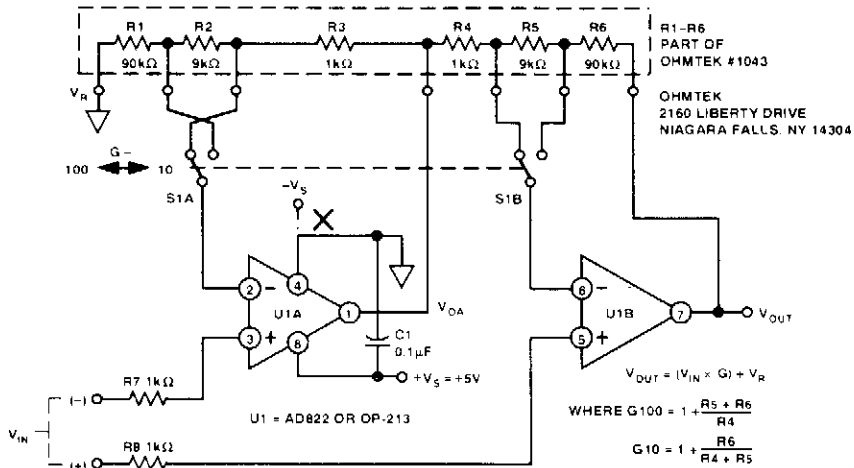

ANALOG DEVICES

Fig. 41-4

This is a two-op-amp programmable-gain instrumentation amplifier for single-supply applications. U1A and U1B are Analog Devices AD822 or OP-213 ICs.

DIFFERENTIAL-INPUT INSTRUMENTATION AMPLIFIER

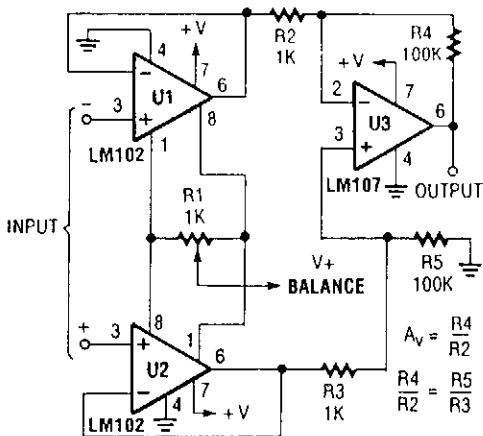

POPULAR ELECTRONICS

Fig. 41-5

HIGH INPUT-IMPEDANCE INSTRUMENTATION AMPLIFIER

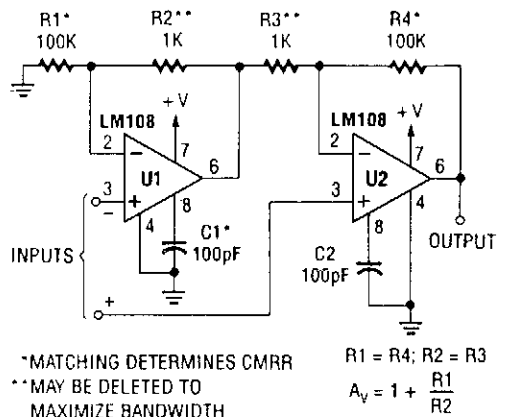

POPULAR ELECTRONICS

Fig. 41-6

ac-COUPLED INSTRUMENTATION AMPLIFIER

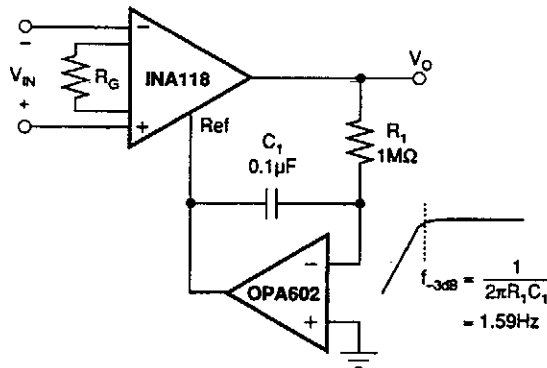

DESIRED GAIN	R _G (Ω)	NEAREST 1% R _G (Ω)
1	NC	NC
2	50.00k	49.9k
5	12.50k	12.4k
10	5.556k	5.62k
20	2.632k	2.61k
50	1.02k	1.02k
100	505.1	511
200	251.3	249
500	100.2	100
1000	50.05	49.9
2000	25.01	24.9
5000	10.00	10
10000	5.001	4.99

BURR-BROWN

Fig. 41-7

LOW-NOISE INSTRUMENTATION AMPLIFIER

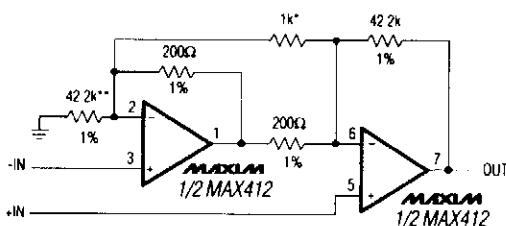

* TRIM FOR GAIN
** TRIM FOR COMMON-MODE REJECTION

MAXIM

Fig. 41-8

A Maxim MAX412 IC amplifier is used in this circuit. The supply-current is ± 5 V at 5 mA.

LOW-POWER INSTRUMENTATION AMPLIFIER

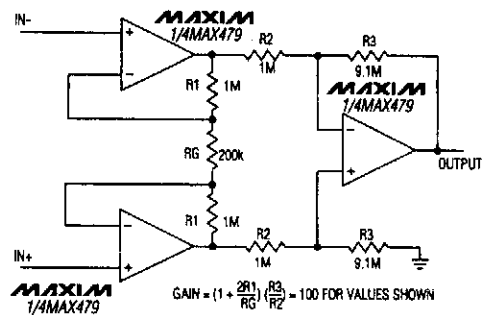

MAXIM

Fig. 41-9

This amplifier requires less than 20 mA from a ± 15 -V supply.

ULTRA-LOW-NOISE SINGLE-SUPPLY INSTRUMENTATION AMPLIFIER

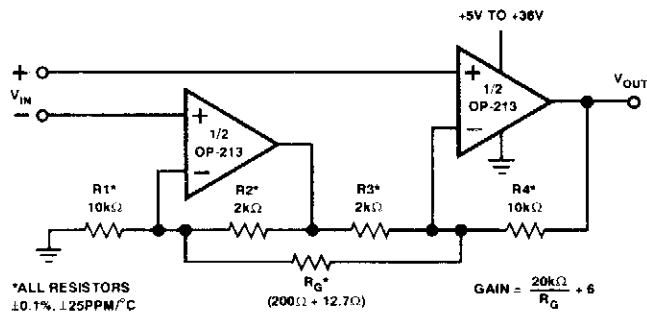

ANALOG DEVICES

Fig. 41-10

INSTRUMENTATION AMPLIFIER

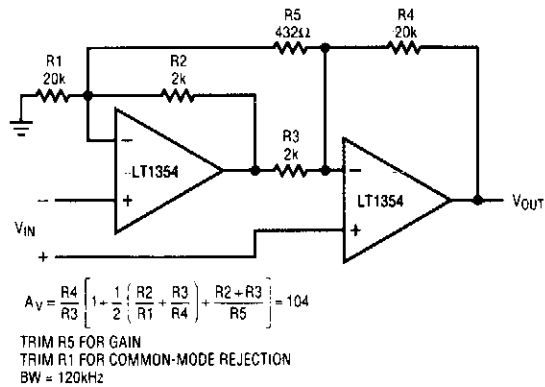

LINEAR TECHNOLOGY

Fig. 41-11

42

Integrator Circuits

The sources of the following circuits are contained in the Sources section, which begins on page 707. The figure number in the box of each circuit correlates to the entry in the Sources section.

Integrator with Bias-Current Compensation

Simple Integrator

ac Integrator

INTEGRATOR WITH BIAS-CURRENT COMPENSATION

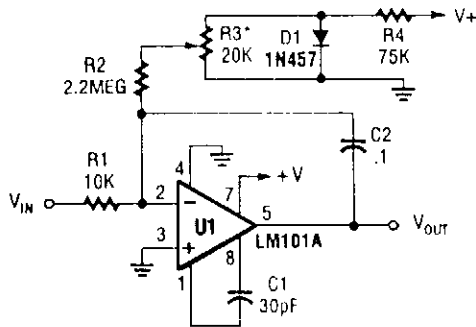

*ADJUST FOR ZERO INTEGRATOR DRIFT.
CURRENT DRIFT TYPICALLY 0.1 n/A°C
OVER -55°C TO 125°C
TEMPERATURE RANGE.

POPULAR ELECTRONICS

Fig. 42-1

SIMPLE INTEGRATOR

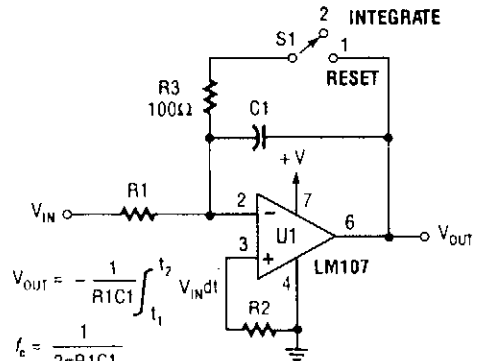

$$V_{OUT} = -\frac{1}{R_1 C_1} \int_{t_1}^{t_2} V_{IN} dt$$

$$t_c = \frac{1}{2\pi R_1 C_1}$$

$$R_1 = R_2$$

FOR MINIMUM OFFSET ERROR DUE
TO INPUT BIAS CURRENT

POPULAR ELECTRONICS

Fig. 42-2

ac INTEGRATOR

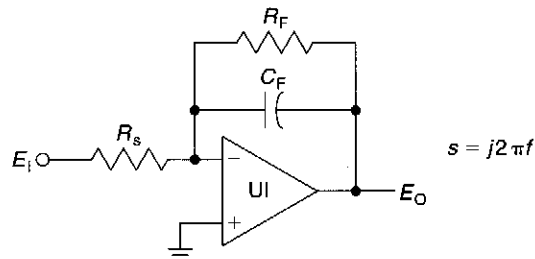

$$\frac{E_O}{E_i}(s) \approx \frac{R_F}{R_S(1 + sR_F C_F)} \approx \frac{1}{R_F C_F} \text{ for } s \gg \frac{1}{R_F C_F}$$

WILLIAM SHEETS

Fig. 42-3

This op-amp circuit can be used with a wide variety of op amps. The values of R_i and R_f depend on gain, but will be 1 kΩ to 1 MΩ in most cases. C_f depends on the pole frequency needed. U1 is a 741-type op amp, etc.

43

Interface Circuits

The sources of the following circuits are contained in the Sources section, which begins on page 707. The figure number in the box of each circuit correlates to the entry in the Sources section.

Timer/ac Line Interface
Interfacing Resistive Transducers

TIMER/ac LINE INTERFACE

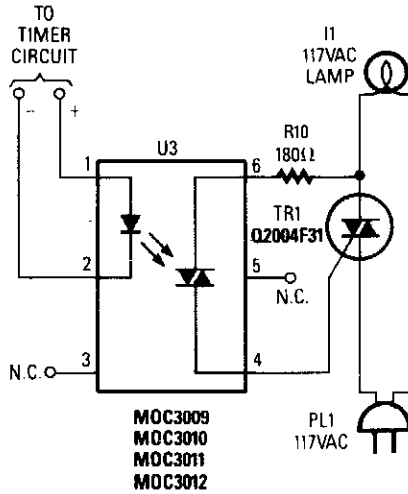

POPULAR ELECTRONICS

Fig. 43-1

This circuit illustrates the use of an optoisolator to enable the control of a triac connected to the ac line and load, while maintaining dc and ac isolation between the ac line and the timer circuit. A 555 or other timer circuit can be used.

INTERFACING RESISTIVE TRANSDUCERS

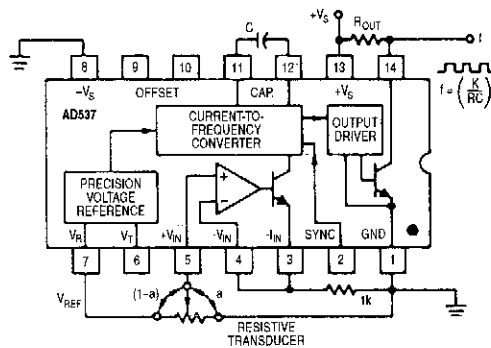

ANALOG DEVICES

Fig. 43-2

All types of resistive-element transducers, such as servo-pots, level indicators, thermistors, photo-sensors, strain gages, and so on, can be directly connected to the AD537. The scale-correction factor, K , is a function of resistance, varying from 0.65 to 0.98 for values from 3 to 100 kΩ.

44

Inverter Circuits

The sources of the following circuits are contained in the Sources section, which begins on page 707. The figure number in the box of each circuit correlates to the entry in the Sources section.

SCR Inverter and Trigger Circuit
Simple Inverter
Vehicle Audio Amplifier Inverter
Positive-to-Negative dc/dc Inverter
1-kW 10-kHz Sine-Wave Inverter

SCR INVERTER AND TRIGGER CIRCUIT

An SCR inverter and trigger circuit. This inverter operates well over a wide load range and can be used to power inductive devices, such as motors. General Electric Semiconductor Prod

ucite Dept

R10, R11	1 Ω , 20 W
R12, R13	12 Ω , 1 W
C5	2-4 μ f units in parallel, G.E. #61F254
D4, D5	G.E. 1N2157
SCR1, SCR2	G.E. C40A
T2	G.E. #9T33Y267
L1	G.E. #9#433 $\frac{3}{4}$ 266

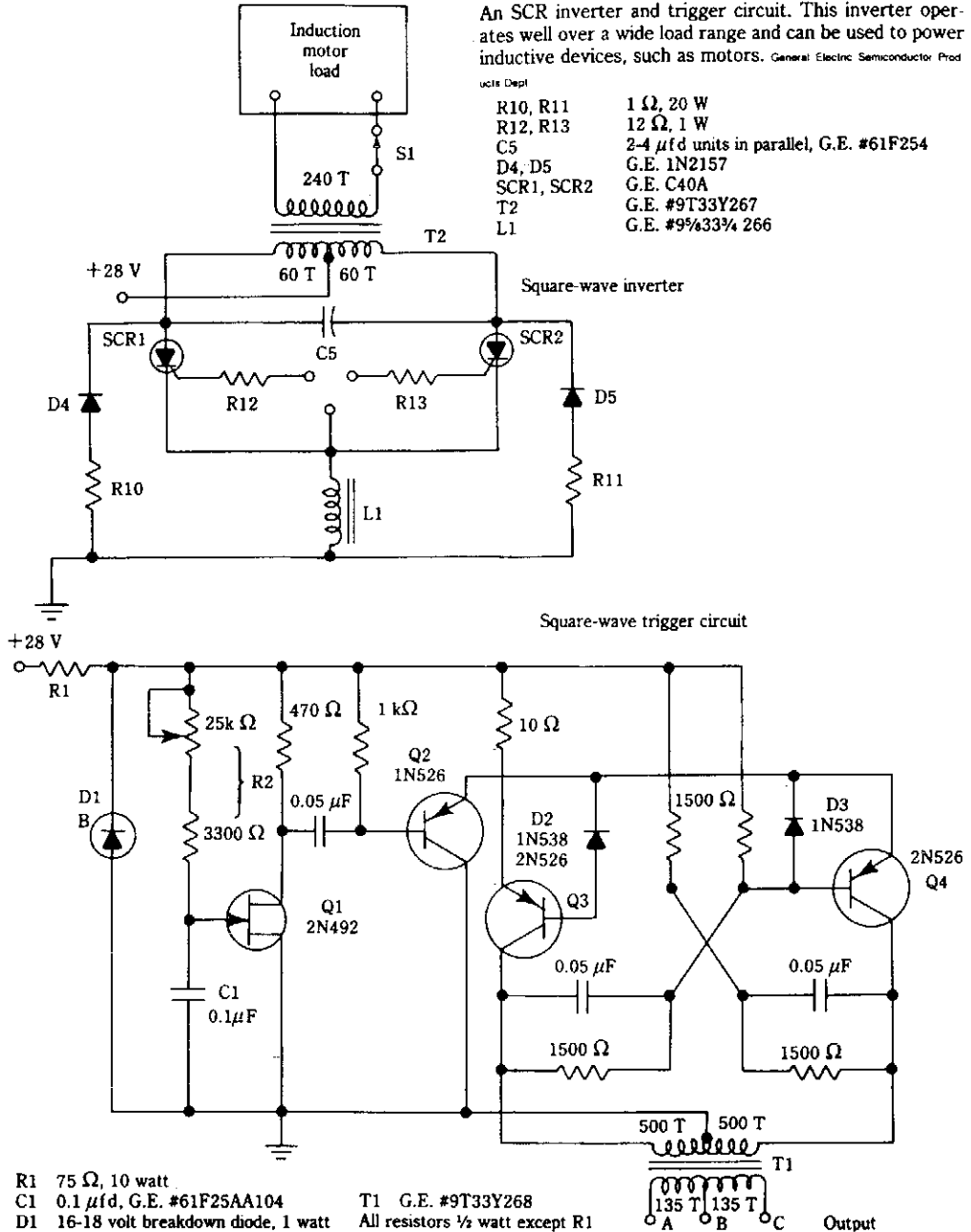

McGraw-Hill

Fig. 44-1

In this circuit, L1 and C5 are used as commutating elements. L1 resonates with C5 at the frequency corresponding to the half period of the waveform.

SIMPLE INVERTER

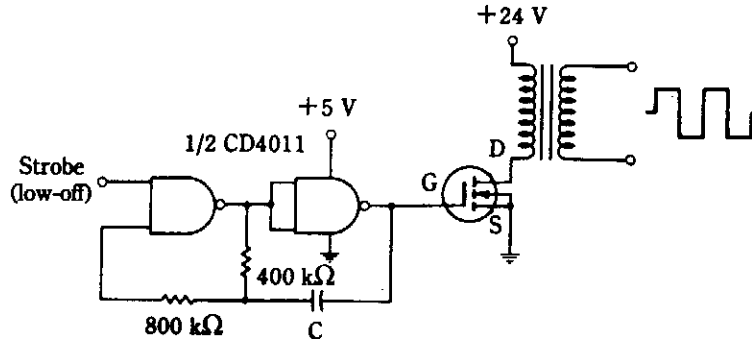

McGRAW-HILL

Fig. 44-2

VEHICLE AUDIO AMPLIFIER INVERTER

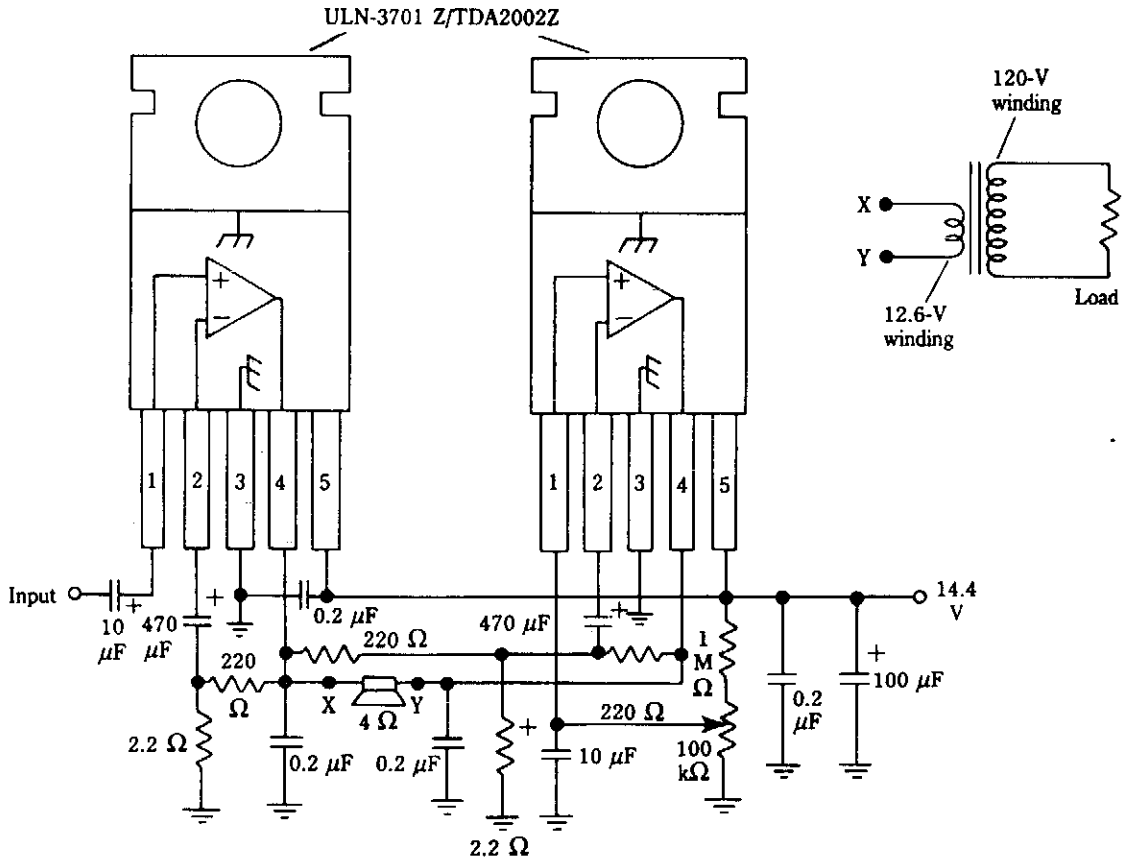

McGRAW-HILL

Fig. 44-3

An audio amplifier can drive a step-up transformer to obtain 120 Vac.

POSITIVE-TO-NEGATIVE dc/dc INVERTER

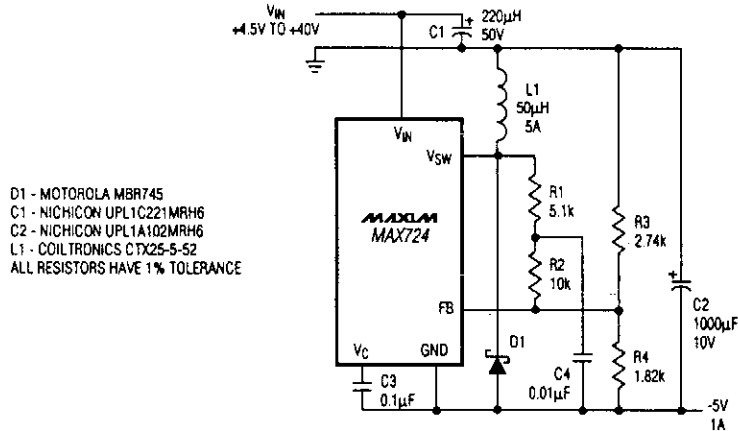

MAXIM

Fig. 44-4

If a source of negative 5 Vdc is needed and only a positive supply is available, this circuit can be used.

1-kW 10-kHz SINE-WAVE INVERTER

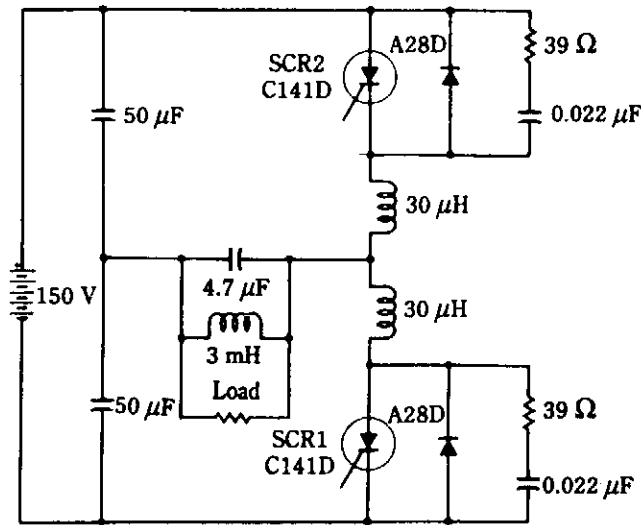

McGRAW-HILL

Fig. 44-5

SCRs can produce considerable power at frequencies up to 30 kHz or more. This circuit can supply 1 kW at 10 kHz. The load is shown as an equivalent load, and practically this will be the primary of the transformer for isolation purposes. The power supply can be a 120-V bridge rectifier and filter combination.

45

Ion Circuits

The sources of the following circuits are contained in the Sources section, which begins on page 707. The figure number in the box of each circuit correlates to the entry in the Sources section.

Negative Ion Generator
Ion-Sensing Electrode
Negative Ion Generator
Ion Detector

NEGATIVE ION GENERATOR

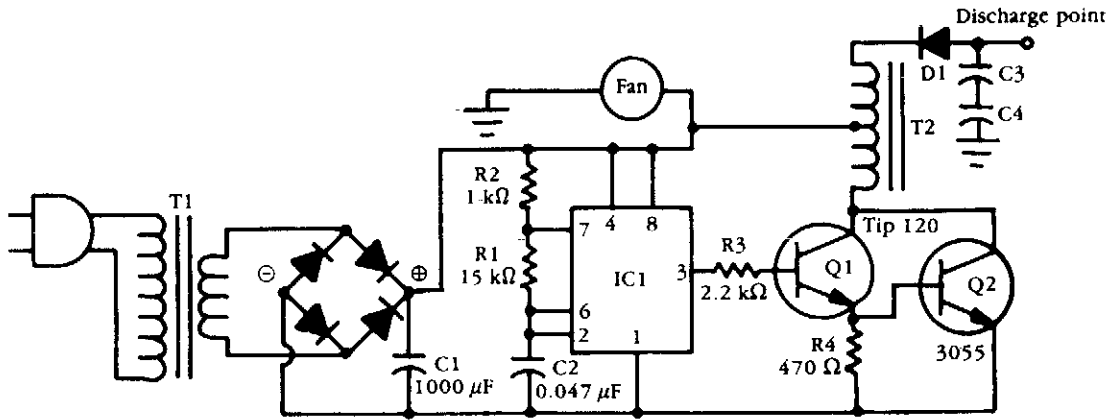

McGRAW-HILL

Fig. 45-1

An NE555 drives a Darlington connected pair of transistors. T1 is a small high-voltage transformer or auto ignition coil, B/W TV flyback, etc. C3, C4, and D1 must be rated for 10 to 15 kV. The fan blows air across the discharge point.

ION-SENSING ELECTROSCOPE

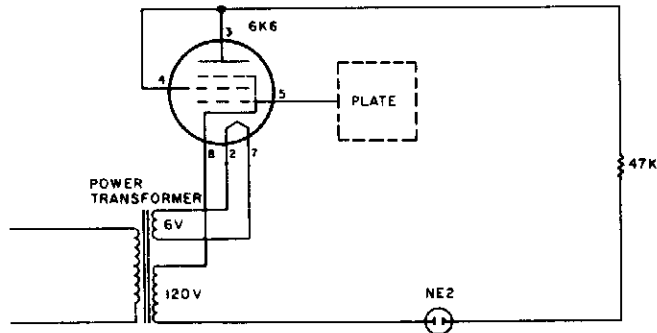

73 AMATEUR RADIO TODAY

Fig. 45-2

Negative ions are sensed by a plate antenna. A negative charge induced on the plate cuts off a vacuum tube, causing the neon indicator to go out.

NEGATIVE ION GENERATOR

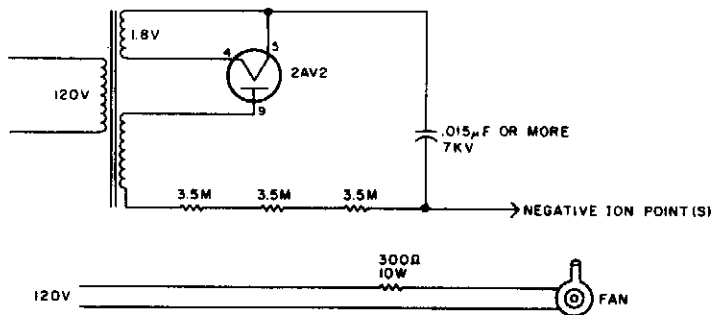

73 AMATEUR RADIO TODAY

Fig. 45-3

In this circuit, air is circulated past a pointed electrode that has a high negative voltage applied to it. The transformer is a small 4- to 6-kV output type with a filament winding. A good source of parts is a discarded electronic bug catcher.

ION DETECTOR

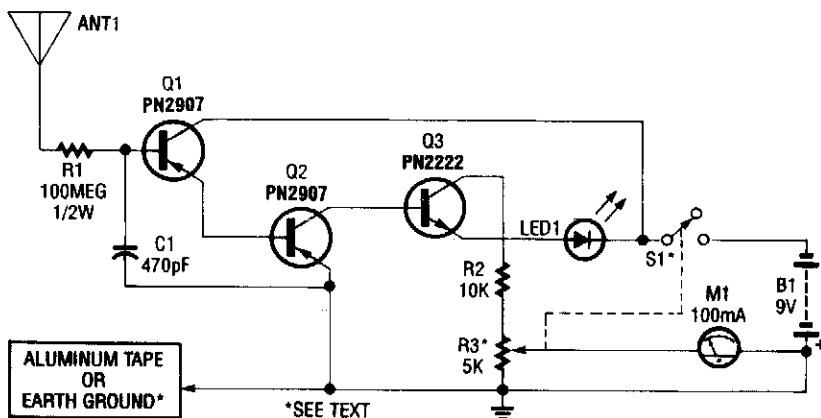

ELECTRONIC HOBBYISTS HANDBOOK

Fig. 45-4

This circuit detects static charges and free ions in the air. It can be used to indicate the presence of ion emissions, high-voltage leakage, static electricity, electrostatic fields, etc. The ground connection is made by either an earth ground or by touching the aluminum foil electrode with your hand. M1 is a 100-µA meter. R3 is a sensitivity control.

46

Laser Circuits

The sources of the following circuits are contained in the Sources section, which begins on page 707. The figure number in the box of each circuit correlates to the entry in the Sources section.

High-Current Drive Circuit for Single Heterostructure Laser Diodes
12-V High-Voltage Supply for He-Ne Laser
Light-Beam Receiver and Sound Effects Generator for Laser Pistols
Laser Diode Transmitter
IR Laser Light Detector
PLL IR Laser Light Receiver
Op-Amp Diode Laser Driver
Laser dc Supply
IC Laser Diode Driver
Pulsed Double Heterostructure Laser Driver

HIGH-CURRENT DRIVE CIRCUIT FOR SINGLE HETEROSTRUCTURE LASER DIODES

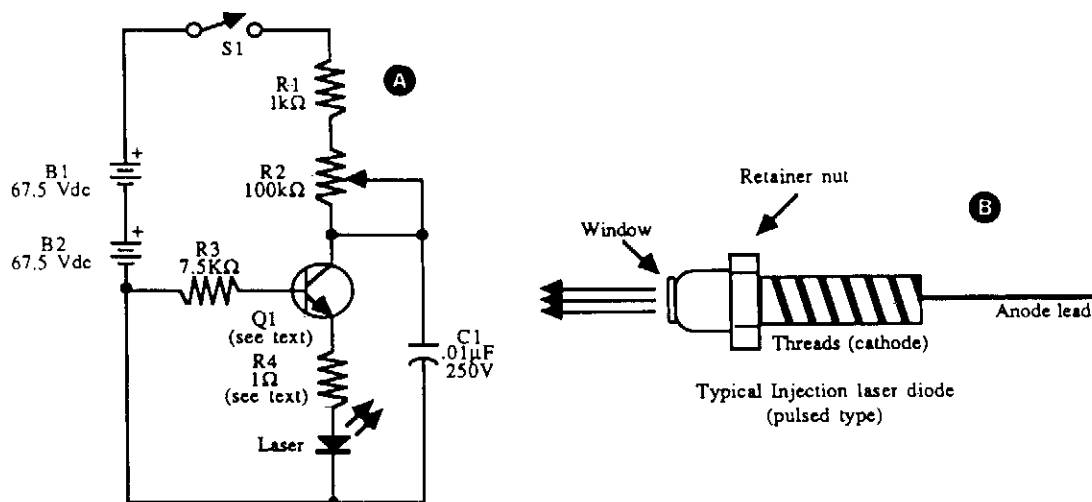

(A) High-current drive circuit for a single heterostructure laser diode. (B) Power leads for the typical sh laser diode, showing single lead for the anode.

R1	1 kilohm resistor
R2	100 kilohm potentiometer
R3	7.5 kilohm resistor
R4	1 ohm resistor, carbon composition, 5 watts
C1	0.01 μ F capacitor, 250 V or higher
Q1	2N2222 or equivalent; see text
B1,B2	67.5 Vdc batteries
Misc.	Single heterostructure laser diode, heatsink

All resistors are 5 to 10 percent tolerance, $\frac{1}{4}$ watt, unless otherwise indicated.

The transistor is operated in the avalanche mode. You might need to try several 2N2222 devices before finding one that oscillates. R2 is adjusted for optimum oscillation. This supply provides pulse of 10 to 20 amps at about 50 ns.

12-V HIGH-VOLTAGE SUPPLY FOR HE-NE LASER

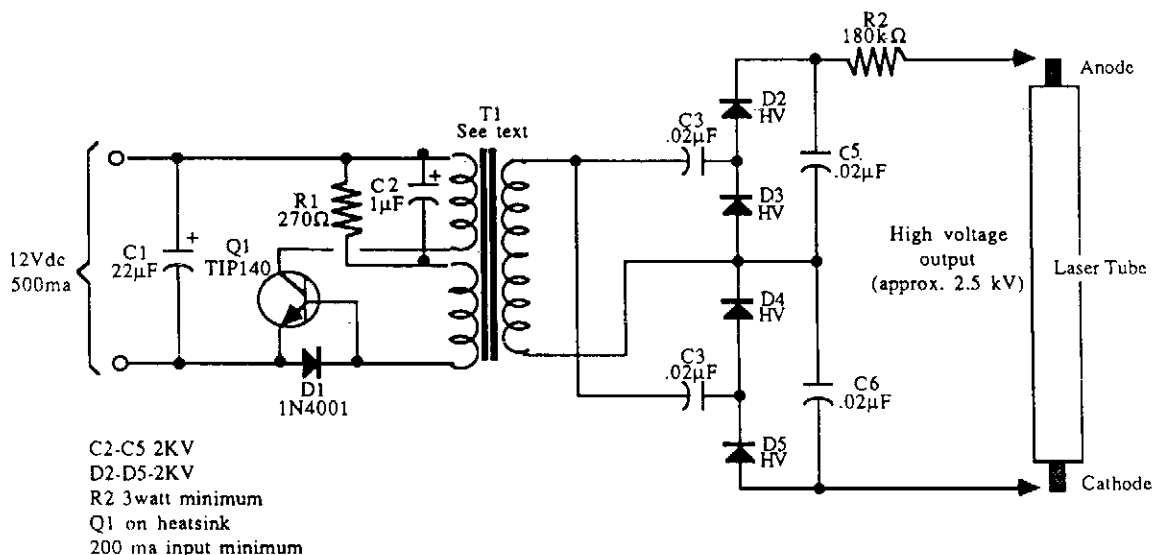

McGRAW-HILL

Fig. 46-2

T1 is a 6-V:330-V dc/dc inverter transformer with a 57.4:1 turn ratio, rated at 7 W.

- R1 270-Ω resistor
- R2 180-kΩ resistor, 3 to 5 W
- C1 22-µF electrolytic capacitor
- C2 1-µF electrolytic capacitor
- C3-C6 0.02-µF capacitor, 1 kV or more
- D1 1N4001 diode
- D2-D5 High-voltage diode (3 kV or more)
- Q1 TIP 140 power transistor
- T1 High-voltage dc-to-dc converter transformer; see text for specifications

All resistors are 5 to 10% tolerance, ¼ W, unless otherwise indicated. All capacitors are 10 to 20% tolerance, rated 35 V or more, unless otherwise indicated.

LIGHT-BEAM RECEIVER AND SOUND EFFECTS GENERATOR FOR LASER PISTOLS

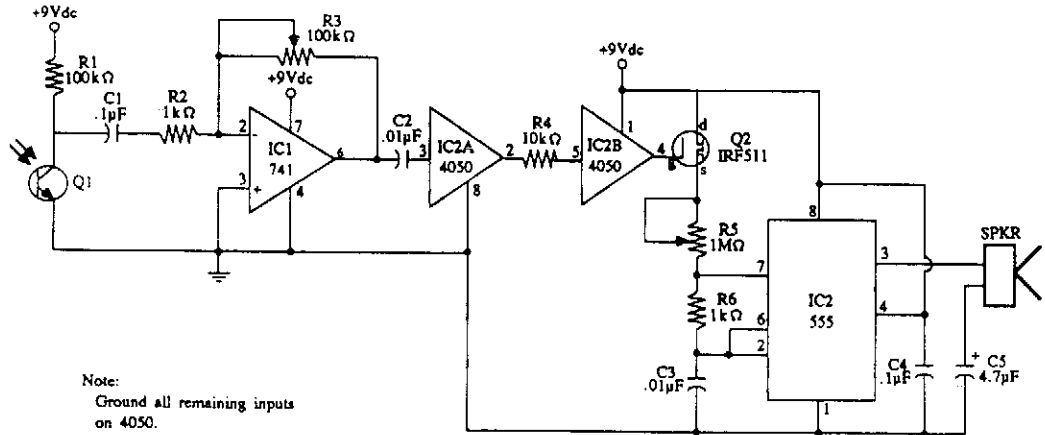

McGRAW-HILL

Fig. 46-3

Schematic diagram for light beam amplifier and sound-effects generator (using a 555 timer IC and speaker). The light striking Q1 generates a siren-like sound.

LASER DIODE TRANSMITTER

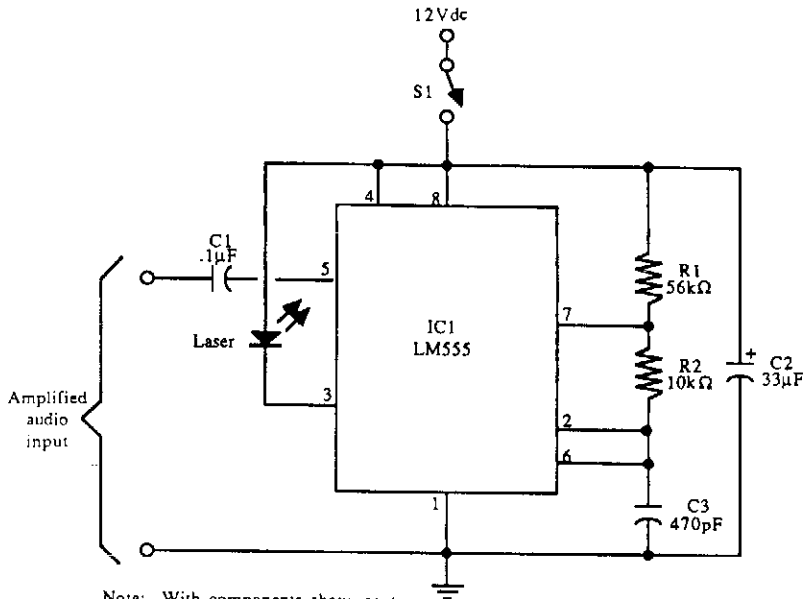

Note: With components show, center frequency is 40.31 kHz; replace R1 with 100K pot to adjust center frequency.

Calculate center frequency using the formula: $f = \frac{1.44}{C3(R1 + 2R2)}$

McGRAW-HILL

Fig. 46-4

IR LASER LIGHT DETECTOR

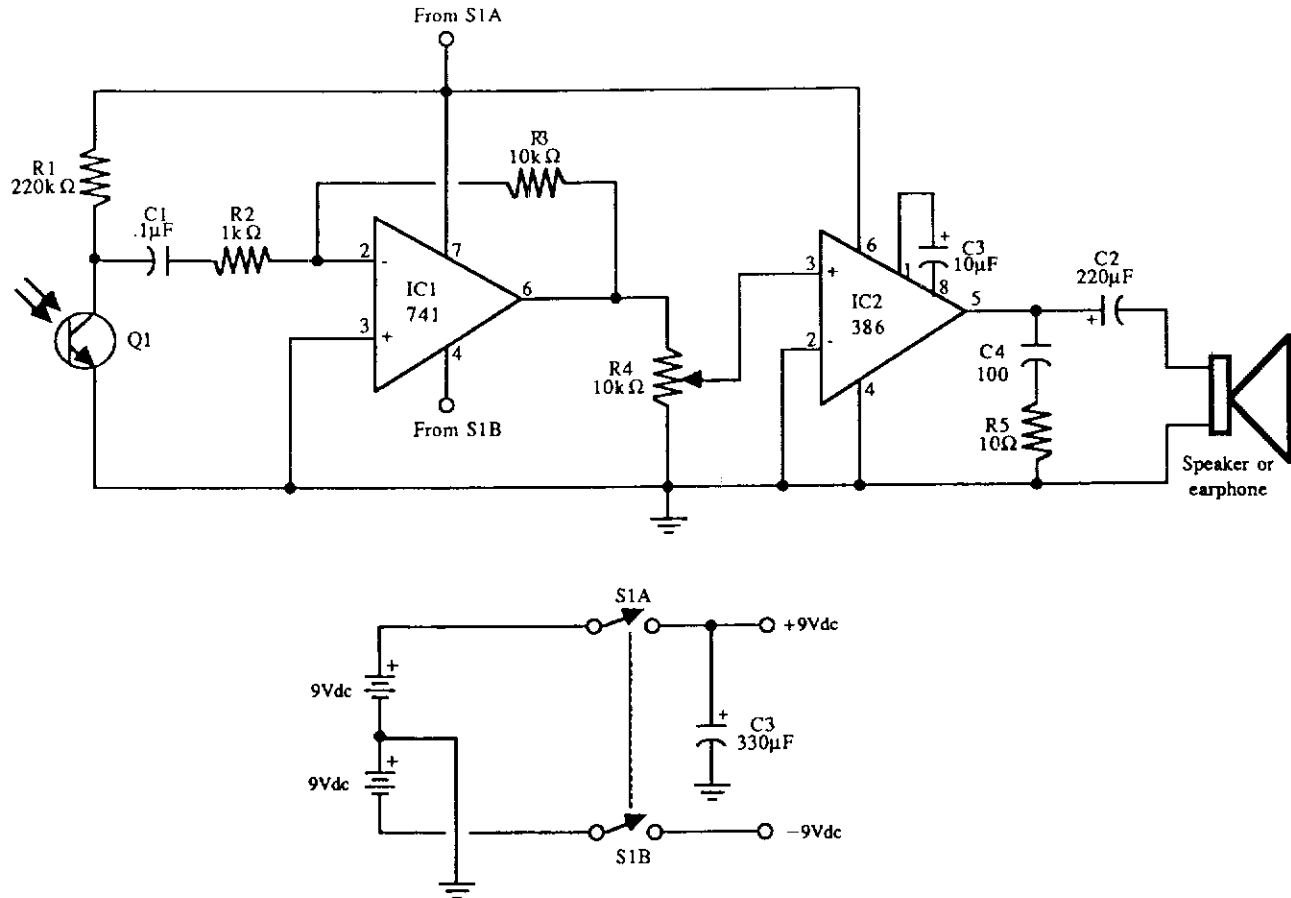

McGRAW-HILL

Fig. 46-5

The universal laser light detector. The output of the LM386 audio amplifier can be connected to a small 8-Ω speaker or earphone. Two 9-V batteries provide power. Decrease R1 to lower sensitivity; increase R3 to increase gain of the op amp (avoid very high gain or the op amp might oscillate). Q1 is an infrared phototransistor.

PLL IR LASER LIGHT RECEIVER

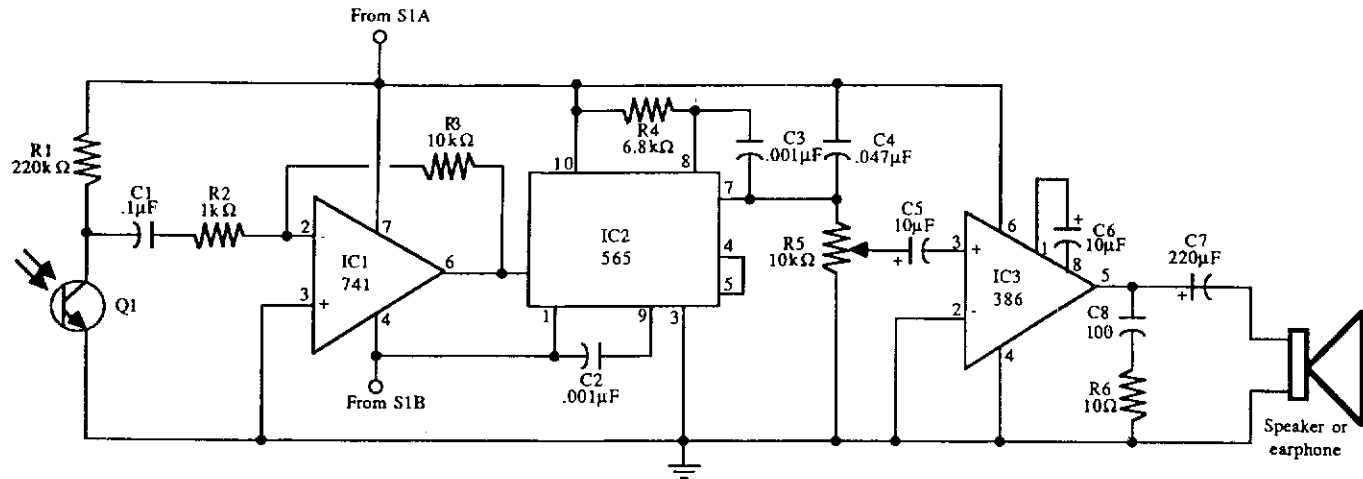

Notes:

Replace R4 with 10k pot to vary center tuning frequency of 565. OK to use other PLL chip.

Increase overall gain of circuit by increasing R3 (up to 1MΩ).

With components shown, center free-running frequency of 565 PLL is 39.75kHz.

Calculate PLL free-running frequency with the formula: $f = \frac{1}{3.7 R4 C2}$ R in kΩ; C in μF

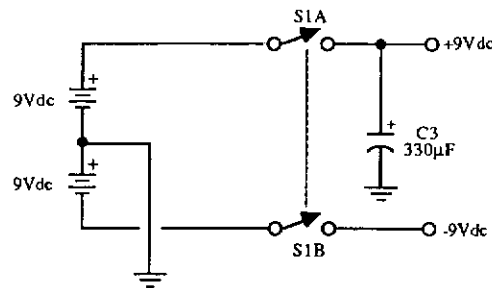

McGRAW-HILL

Fig. 46-6

Circuit schematics for the 555-based PLL laser light PFM receiver. Although R4 is shown as a resistor, you might want to substitute it with a 10-kΩ precision potentiometer so that you can “dial in” the center frequency of the transmitter. Experiment with the value of C₁ for the best high-frequency response. Notice that circuit is functionally identical to the laser light detector/receiver shown in the figure, but with the addition of the 565.

OP-AMP DIODE LASER DRIVER

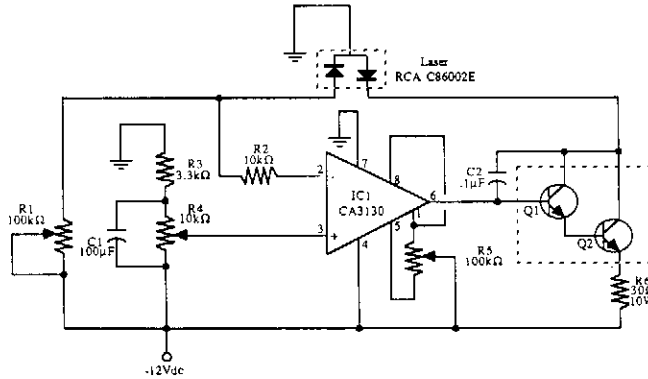

McGRAW-HILL

Fig. 46-7

This circuit is one way to automatically adjust drive current using a discrete op amp. Use the transistors specified or replace them with a suitable Darlington power transistor (such as TIP 120).

- | | |
|--------|--|
| IC1 | RCA CA 313 operational amplifier |
| R1, R5 | 100-kΩ potentiometer |
| R2 | 10-kΩ resistor |
| R3 | 3.3-kΩ potentiometer |
| R4 | 10-kΩ potentiometer |
| R6 | 30-Ω, 10-W resistor |
| C1 | 100-μF electrolytic capacitor |
| C2 | 0.1-μF disc capacitor |
| Q1 | 2N2101 transistor |
| Q2 | 2N3585 transistor |
| Laser | RCA C86002 (or equivalent laser diode) |

LASER dc SUPPLY

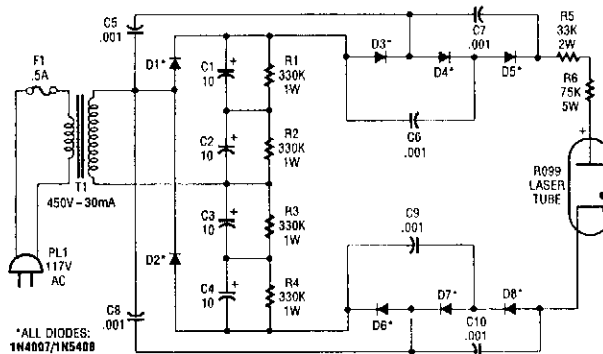

POPULAR ELECTRONICS

Fig. 46-8

The supply provides about 6 kVdc when open circuited, dropping to around 1375 Vdc when loaded. The R099 is a laser tube.

IC LASER DIODE DRIVER

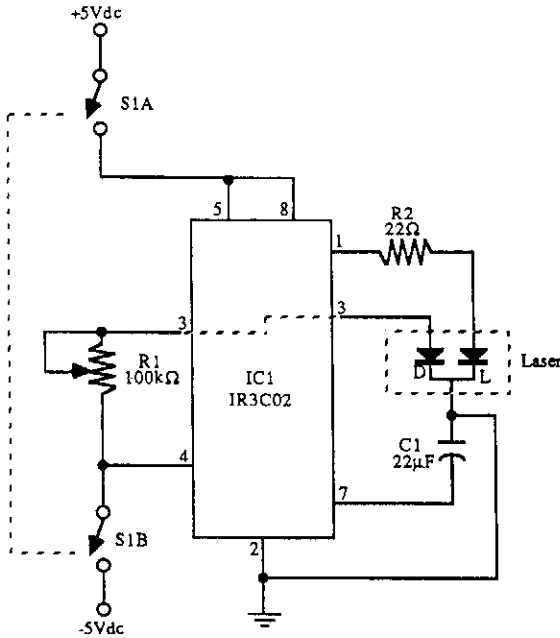

- IC Sharp IR3C02 laser diode driver IC
- R1 100-k Ω resistor
- R2 22- Ω resistor
- C1 22- μ F electrolytic capacitor
- S1 DPDT switch
- Misc. Double heterostructure laser diode (such as Sharp LT020), heatsink

McGRAW-HILL

Fig. 46-9

PULSED DOUBLE-HETEROSTRUCTURE LASER DRIVER

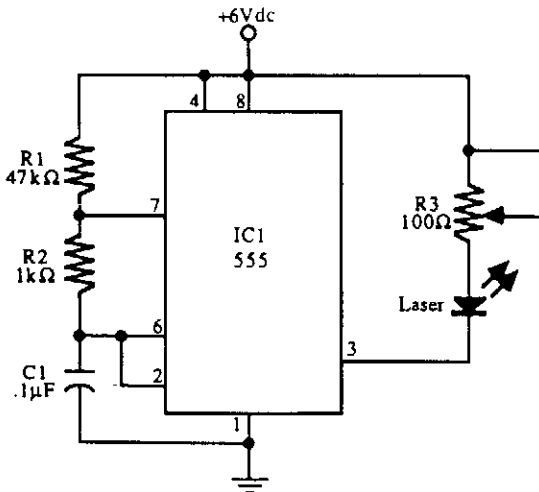

- IC1 555 timer IC
- R1 47-k Ω resistor
- R2 1-k Ω resistor
- R3 100-k Ω potentiometer
- C1 0.1- μ F disc capacitor
- Misc. Double heterostructure laser diode, heatsink

All resistors are 5 to 10% tolerance, $\frac{1}{4}$ W. All capacitors are 10 to 20% tolerance, rated 35 V or more.

McGRAW-HILL

Fig. 46-10

47

Light-Controlled Circuits

The sources of the following circuits are contained in the Sources section, which begins on page 707. The figure number in the box of each circuit correlates to the entry in the Sources section.

Traffic Light-Sequencer Circuit
Tachometer Adapter
Sun-Tracking Circuit for Solar Arrays
Optical Fringe Counter
Low-Noise Light Sensor with dc Servo
Photodiode Amplifier
Light-Switched LED Blinker
Single-Supply Photodiode Amplifier
Light-Controlled Monostable
Darkness Monitor
Programmable Light-Activated Relay
Traffic Light Controller
Colorimeter
Eight Decade Light Meter
LED Lightwave Communications Transmitter
LED Lightwave Receiver
Solar Power Supply
Solar Power Supply with Linear Regulator
Photodiode Log Converter/Transmitter
Rechargeable Solar Power for Sun Tracker

TRAFFIC LIGHT-SEQUENCER CIRCUIT

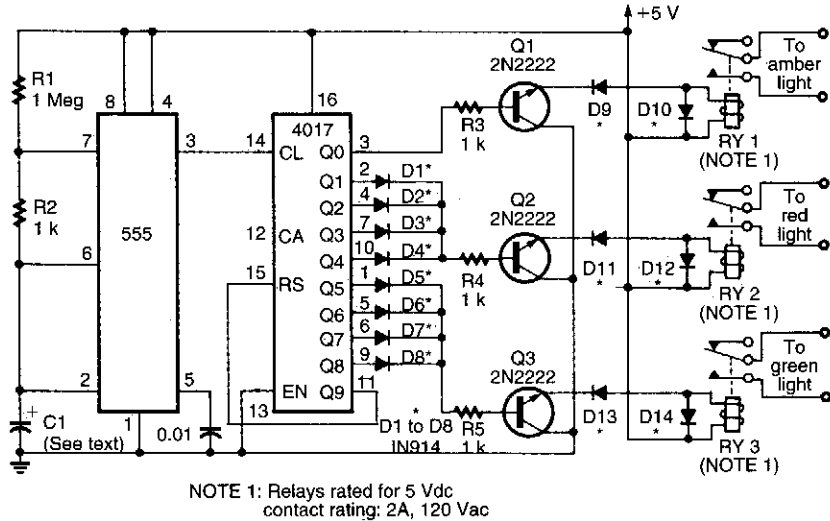

Fig. 47-1

ELECTRONICS NOW

This circuit uses a 555 timer to drive a 4017 counter. The counter outputs drive transistor relay drivers. Time lights “on” can be proportioned by changing connections of outputs of counter.

TACHOMETER ADAPTER

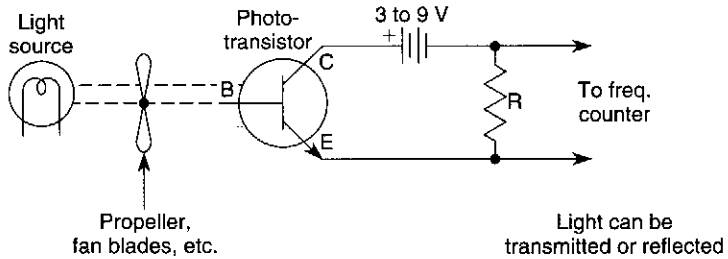

Fig. 47-2

WILLIAM SHEETS

Use of a phototransistor and light source can enable a frequency counter to act as a tachometer:

$$RPM = 60 \times \frac{\text{Frequency Counter Reading Hz}}{\# \text{ Blades or Spokes}}$$

The light source is interrupted by the number of propeller blades, fan blades, spokes, or other marking. *R* can be anywhere from 1 to 100 kΩ. Try several values for best results.

SUN-TRACKING CIRCUIT FOR SOLAR ARRAYS

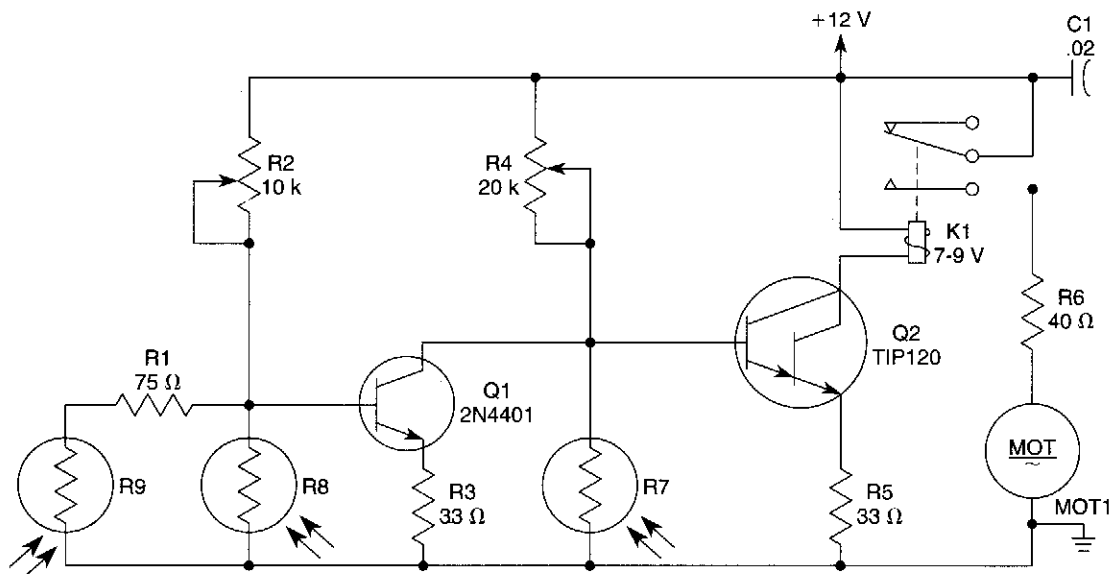

POPULAR ELECTRONICS

Fig. 47-3

The sun tracker uses a combination of three photoresistors. R7, R8, and R9, to ensure that the circuit will follow the sun during the day, but not look for it at night. Photoresistor cells, R7, R8, and R9 have a value of $160\ \Omega$ in full sunlight and $4880\ \Omega$ in the shade, that is not absolutely critical. R7 is mounted in a "well" with a narrow slit so that sunlight falls upon it only when the photoresistor is pointed directly at the sun. When that occurs, the resistance of R7 drops. That photoresistor and potentiometer R4 form a voltage divider at the base of the Darlington transistor, Q1. When R7's resistance is low, Q1 will be kept off.

When the sun swings a little westward, R7 will no longer be in sunlight, causing its resistance to go up, which raises the base voltage of Q1 and turns that Darlington on. That, in turn closes the relay, K1, providing current to the drive motor, MOT1, which is a 1.5-Vdc, low-torque hobby motor. The motor then turns slowly (resistor R6 limits the maximum current to the motor and keeps it from running too fast), putting R7 in direct sunlight again; Q1's base voltage then drops and the tracker stops. That is repeated again and again as the sun moves across the sky. Photoresistor R8 is mounted on the outside of the well so that it receives a wide angle of full sunlight. When the sun is shining, R8's resistance is low, keeping Q2 turned off, and allowing the tracker to act as described, without interference. But if the sun "slips" behind a cloud, R8's resistance goes high, producing a forward bias on the base of Q2. That turns that transistor on and sinks the base of Q1 to near ground so that Q1 then remains off. That immobilizes the tracker drive; that also keeps the drive shut down in the dark of night.

Photoresistor, R9, is the dawn sensor. It is mounted on the back of the sun tracker. When the tracker stops at sunset, pointing toward the west, R9 is pointing toward the east. When the sun rises the following morning and shines on R9, its resistance goes low, turning Q2 off and allowing Q1's base to go high. That presents current to the relay and therefore to the drive motor, causing the tracker to swing around to the east.

OPTICAL FRINGE COUNTER

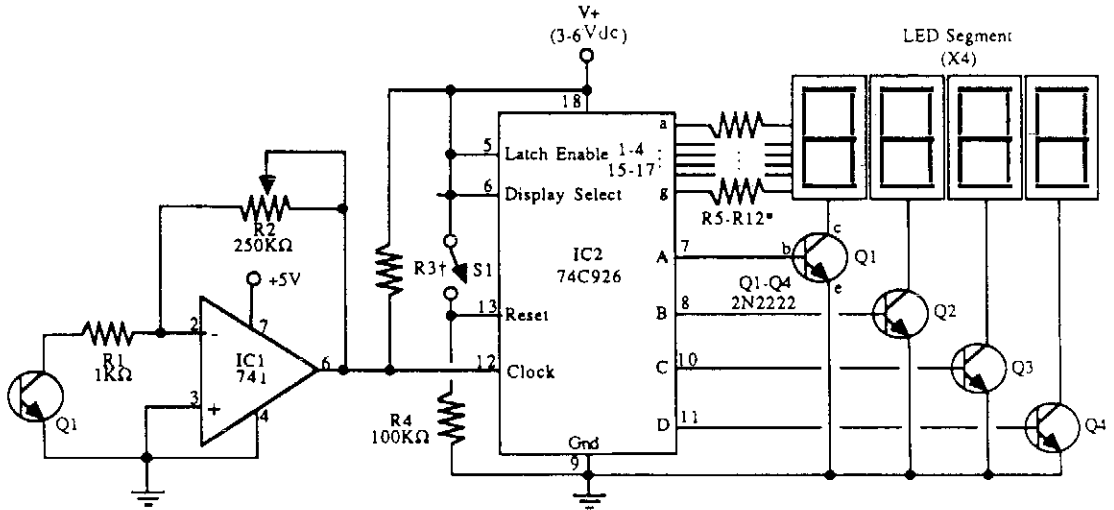

* Not required if +V is 4V or less
 † Optional, 10KΩ to 10MΩ, for sensitivity

McGRAW-HILL

Fig. 47-4

For work with interferometer and optical experiments, this fringe counter can be useful. Photo transistor Q1 provides light and dark sensing. As the sensor is moved across the fringe pattern alternate light and dark areas translate to an electrical waveform. This is amplified by IC1 and counted by IC2. A Schmitt trigger circuit can be added, if desired.

LOW-NOISE LIGHT SENSOR WITH dc SERVO

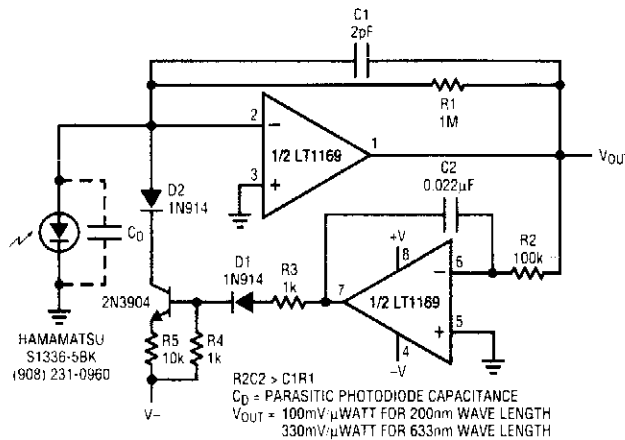

LINEAR TECHNOLOGY

Fig. 47-5

PHOTODIODE AMPLIFIER

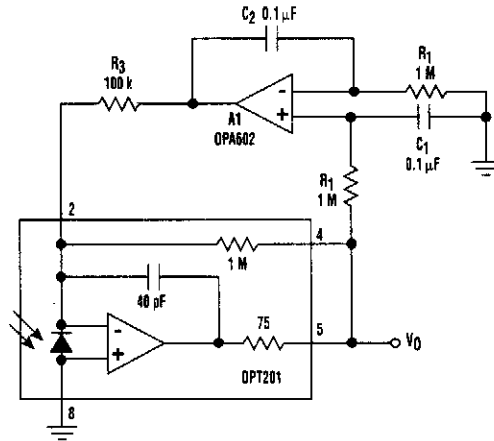

ELECTRONIC DESIGN

Fig. 47-6

A photodiode amplifier combined with a dc-restoration circuit will reject low-frequency ambient background light, easing measurement of a light signal.

LIGHT-SWITCHED LED BLINKER

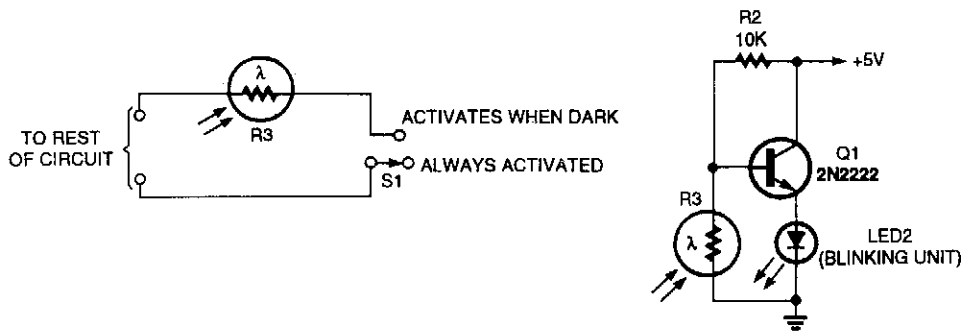

POPULAR ELECTRONICS

Fig. 47-7

This circuit can be used to flash an LED during periods of darkness. Use it for burglar alarm simulators for boats, docks, autos, etc.

SINGLE-SUPPLY PHOTODIODE AMPLIFIER

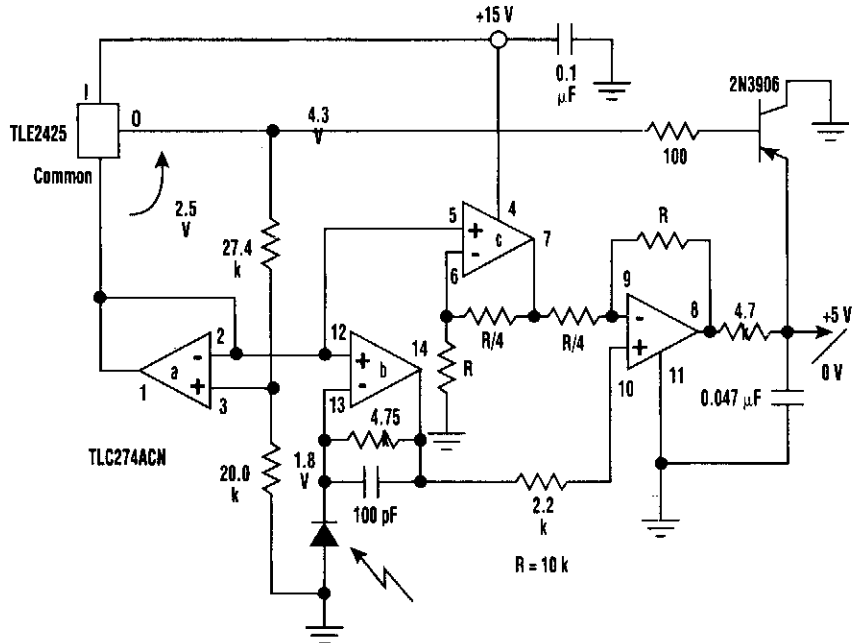

ELECTRONIC DESIGN

Fig. 47-8

This circuit provides a reverse-bias operating point and output voltage offset and uses a single-polarity power supply. The floating reference voltage from TLE2425 serves to bias the diode in a reverse-polarity mode. It also provides a clamping level at the output. Consequently, linear response to illumination is maintained for a 5-V range from dark current to full sunlight conditions.

LIGHT-CONTROLLED MONOSTABLE

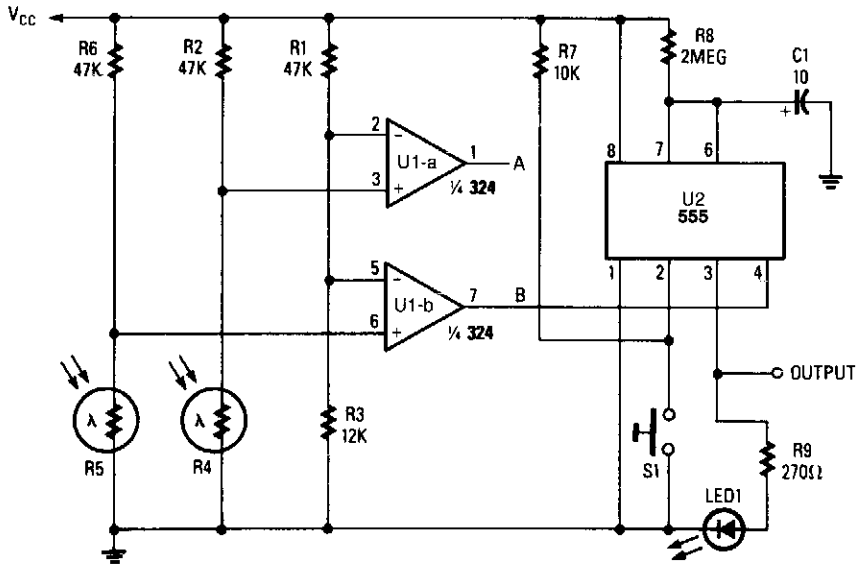

POPULAR ELECTRONICS

Fig. 47-9

The light-controlled monostable was produced by combining a 555 monostable multivibrator with a pair of light-controlled comparators. The circuit can be used to enable the operation of the load device, depending on the time of day. During the daylight hours, the timer U2, is disabled, and so produces no output. However, during the nighttime hours, U2 is enabled by the output of U1-b so that pressing S1 initiates a timing cycle, which activates LED1 for a time determined by R8 and C1.

DARKNESS MONITOR

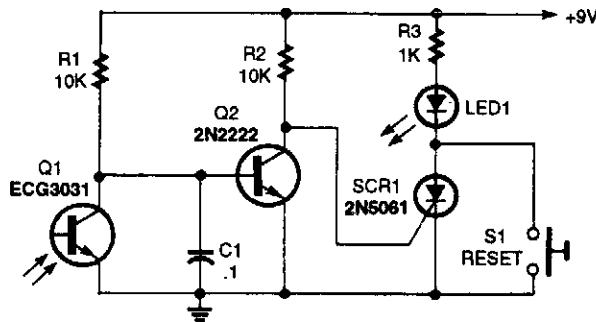

POPULAR ELECTRONICS

Fig. 47-10

When light strikes detector Q1, Q2 is cut off, allowing bias to reach SCR1, triggering SCR1 and lighting LED1. S1 resets the circuit.

PROGRAMMABLE LIGHT-ACTIVATED RELAY

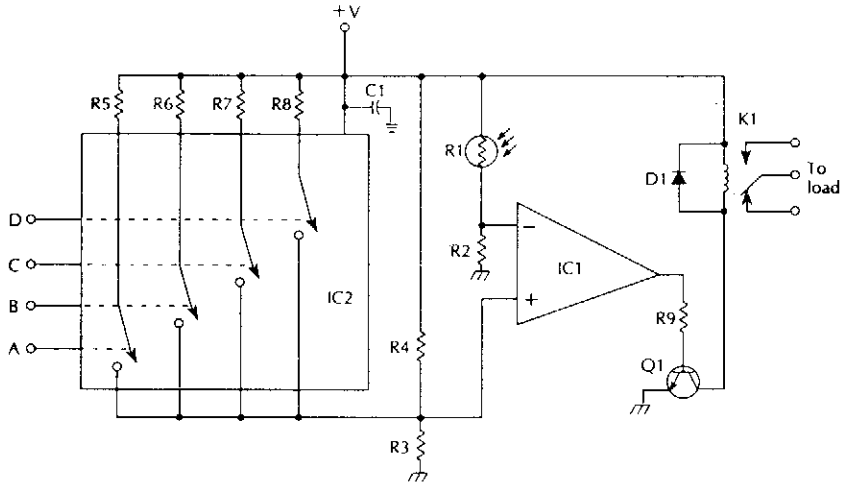

McGRAW-HILL

Fig. 47-11

Digital inputs A, B, C, D select different light levels by varying the value of bridge circuit resistance R_4 .

IC1	741 op amp
IC2	CD4066 quad bilateral switch
Q1	NPN transistor (2N2222, 2N3904, or similar)
D1	diode (1N4002, or similar)
C1	0.1- μ F capacitor
R1	photoresistor
R2, R3	390-k Ω , 1/4-W 5% resistor
R4, R5	1-M Ω , 1/4-W 5% resistor
R6	820-k Ω , 1/4-W 5% resistor
R7	470-k Ω , 1/4-W 5% resistor
R8	270-k Ω , 1/4-W 5% resistor
R9	100-k Ω , 1/4-W 5% resistor
K1	relay to suit load

TRAFFIC LIGHT CONTROLLER

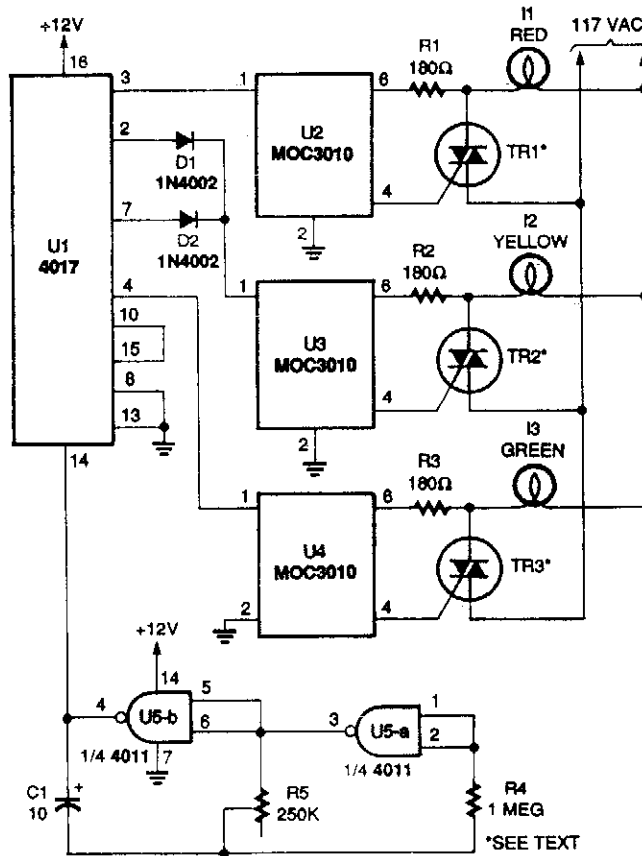

POPULAR ELECTRONICS

Fig. 47-12

Oscillator U5A-B drives a 4017 divide-by-10 counter. The first output of U1 appears at pin 3, which supplies a positive voltage to U2, a MOC 3010 optocoupler/triac-driver IC, turning it and triac TR1 on. That lights I1, the red lamp. The second output appears at pin 2 and passes through D1 to the second MOC 3010, U3, thereby lighting the yellow lamp, I2. The third output at pin 4 turns on U4 and the green lamp, I3. The fourth output at pin 7 travels through D2 and into U3 to light the yellow lamp, I2, again.

If you would like the traffic-light system to follow the normal sequence of green, yellow, and red, make the following circuit changes: Disconnect pins 10 and 15 of U1 from each other. Remove D1 and D2 and connect pin 2 of U1 to pin 1 of U3. Then connect pins 7 and pins 15 of U1 together. Use U2 to drive I3 (the green light) and U4 for I1 (the red light).

COLORIMETER

TABLE 1—LED COLORS AND CODES

LED	Wave-length	Color	Activation Value
LED1	470 nm	Blue	$2^0=1$
LED2	560 nm	Green	$2^1=2$
LED3-a	590 nm	Yellow	$2^2=4$
LED3-b	700 nm	Red	$2^3=8$
LED4	630 nm	Orange	$2^4=16$
LED5	665 nm	Crimson	$2^5=32$
LED6	482 nm	Aqua	$2^6=64$

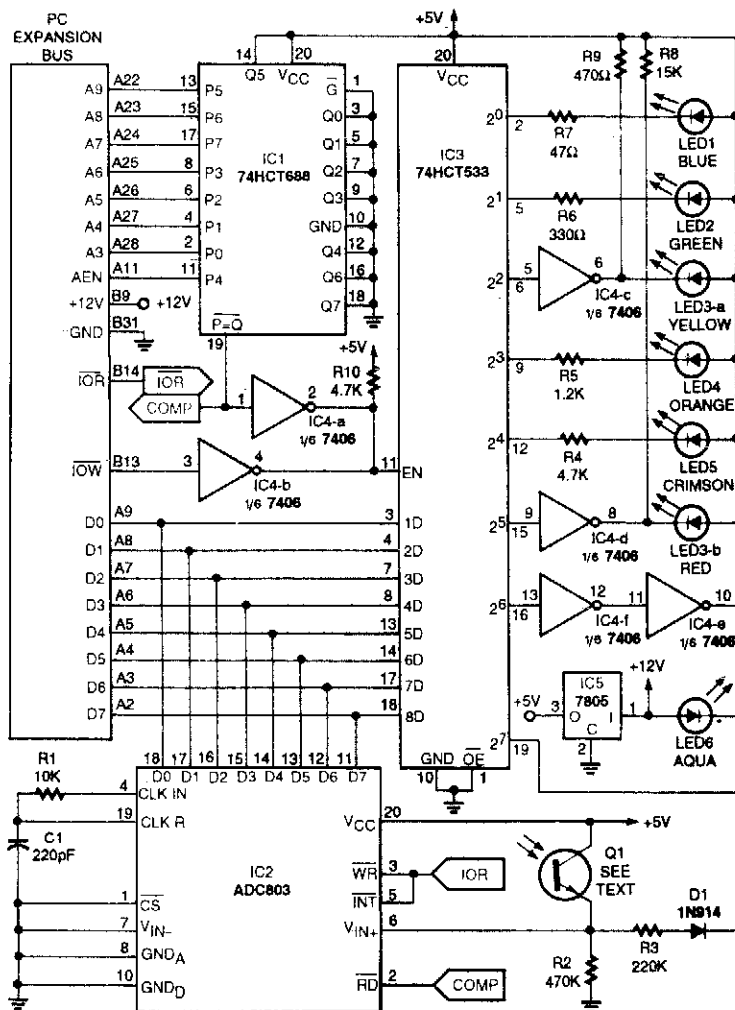

COLORIMETER (Cont.)

LISTING 1—CALIBRATION PROGRAM

```
10 'CALIBRAT.BAS calibration program
20 CLS:KEY OFF:N=0:ADR=512:OPEN"R",1,"CAL1",16:OPEN"r",2,"cal2",24
30 FIELD 1,2AS B$,2AS G$,2AS Y$,2AS O$,2AS C$,2AS R$,2AS A$,2AS AG$
40 FIELD 2,24AS ID$
50 PRINT "reference number",N+1:OUT ADR,255:BEEP:INPUT "Enter Name of Standard
or 'E' To End";TEMPID$
60 IF TEMPID$="E" OR TEMPID$="e" THEN N=0: GOTO 200
70 IF TEMPID$="n" THEN INPUT"enter n to redo ",N:N=N-1:GOTO 50
80 N=N+1:FOR H=0 TO 7:K=0:IF H<7 THEN Z=2^H ELSE Z=194
90 OUT ADR,Z:FOR I=1 TO 500:NEXT I
100 FOR J=1 TO 50:K=K+INP(ADR):NEXT J
110 IF H=0 THEN LSET B$=MKI$(K)
120 IF H=1 THEN LSET G$=MKI$(K)
130 IF H=2 THEN LSET Y$=MKI$(K)
140 IF H=3 THEN LSET O$=MKI$(K)
150 IF H=4 THEN LSET C$=MKI$(K)
160 IF H=5 THEN LSET R$=MKI$(K)
170 IF H=6 THEN LSET A$=MKI$(K)
180 IF H=7 THEN LSET AG$=MKI$(K)
190 NEXT H:LSET ID$=TEMPID$:PUT 1,N:PUT 2,N:CLS:GOTO 50
200 N=N+1:GET #1,N:GET #2,N:IF N>(LOF(1)/16) THEN END
210 B=CVI(B$):G=CVI(G$):Y=CVI(Y$):O=CVI(O$):C=CVI(C$):R=CVI(R$):A=CVI(A$):
AG=CVI(AG$)
220 PRINT N, ID$:GOTO 200
```

LISTING 2—IDENTIFICATION PROGRAM

```
1 'IDENTIFY.BAS identification program
10 ADR=512:OUT ADR,255:PRINT:INPUT "Hit Enter To Scan/Identify Unknown
Color":A
20 IF A=9 THEN RUN"fcsl"
30 ERP=1E+20:OPEN"R",1,"cal1",16
40 FOR H=0 TO 7:K=0:IF H<7 THEN Z=2^H ELSE Z=194
50 OUT ADR,Z: FOR I=1 TO 500:NEXT I
60 FOR J=1 TO 50:K=K+INP(ADR):NEXT J
70 IF H=0 THEN BU=K ELSE IF H=1 THEN GU=K ELSE IF H=2 THEN YU=K
80 IF H=3 THEN OU=K ELSE IF H=4 THEN CU=K ELSE IF H=5 THEN RU=K
90 IF H=6 THEN AU=K ELSE IF H=7 THEN AGU=K
100 NEXT H:BEEP
110 OUT 512,255:OPEN"r",2,"cal2",24:FIELD 1,2AS B$,2AS G$,2AS Y$,2AS O$,2AS
C$,2 AS R$,2AS A$,2AS AG$:B=LOF(1)/16
120 FOR N=1 TO B:GET #1,N:IF ABS( CVI(B$)-BU)>400 THEN 140
130 ER=(CVI(B$)-BU)^2+(CVI(G$)-GU)^2+(CVI(Y$)-YU)^2+(CVI(O$)-OU)^2+(CVI(C$)-
CU)^2+(CVI(R$)-RU)^2+1*((CVI(A$)-AU)^2)+2*((CVI(AG$)-AGU)^2):IF ER<ERP
THEN ERP= ER:NN=N
140 NEXT N
150 FIELD 2, 24AS ID$: GET #2,NN
160 CLS:PRINT "Best Color Match",ID$:PRINT"Relative Error",ERP:PRINT"reference
number",NN:RUN
```

A hardware/software combination activates. In turn, one of several LEDs emits a portion of the visible spectrum. A phototransistor measures the light reflected by the surface being measured, and an 8-bit analog-to-digital converter (ADC) translates the phototransistor's output into a digital format that the computer can interpret. Seven LEDs (blue, aqua, green, yellow, orange, crimson, and red) provide a range of readings across the visible spectrum. Lack of spectral continuity among adjacent LED colors could skew results, so the circuit provides built-in compensation for this error.

Two simple BASIC programs control the circuit's operation. One allows you to define a set of standards by measuring known color samples and recording the values with an associated name. The other program measures unknown samples and provides the best match with the defined standards, as well as a relative error factor.

EIGHT-DECADE LIGHT METER

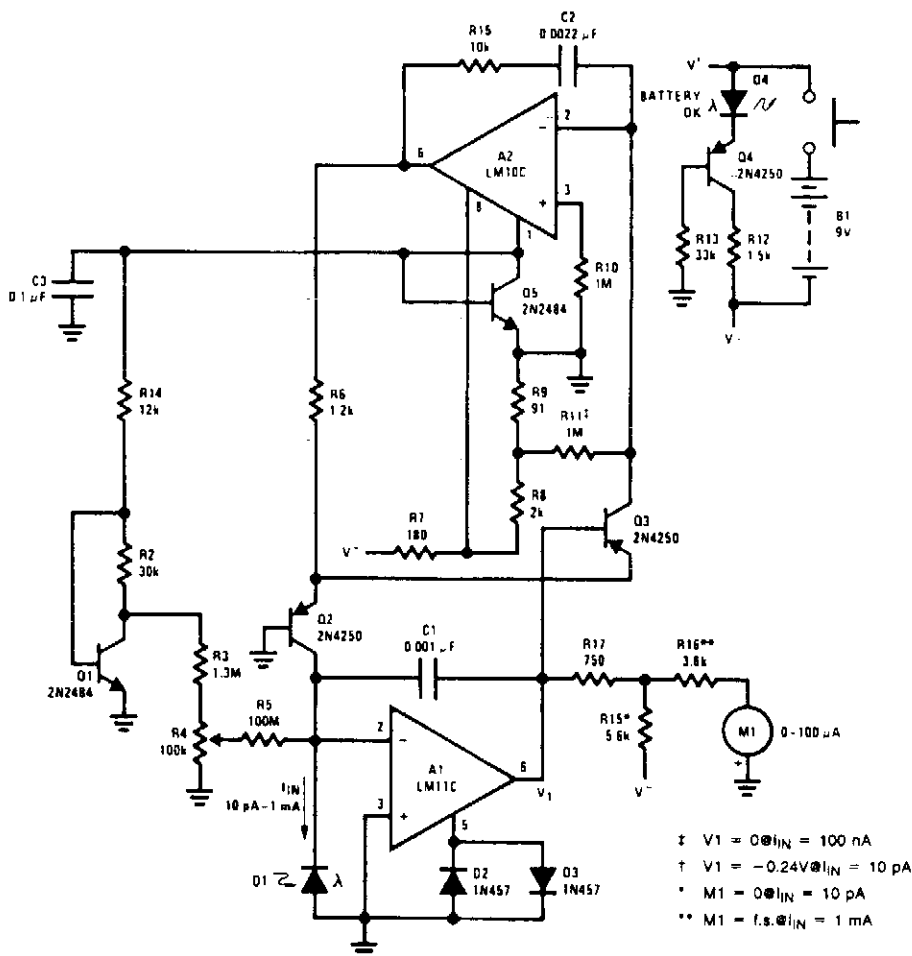

NATIONAL SEMICONDUCTOR

Fig. 47-14

A logarithmic amplifier is adapted to a battery-powered light meter. An LM10, combined op amp and reference, is used for the second amplifier and to provide the regulated voltage for offsetting the logging circuit and powering the bias-current compensation. This can provide input current resolution of better than $\pm 2 \text{ pA}$ over 15 to 55° C. Because a meter is the output indicator, there is no need to optimize frequency compensation. Low-cost single transistors are used for logging because the temperature range is limited. The meter is protected from overloads by clamp diodes D2 and D3.

Silicon photodiodes are more sensitive to infrared than visible light, so an appropriate filter must be used for photography. Alternately, gallium-arsenide-phosphide diodes with suppressed IR response are becoming available.

LED LIGHTWAVE COMMUNICATIONS TRANSMITTER

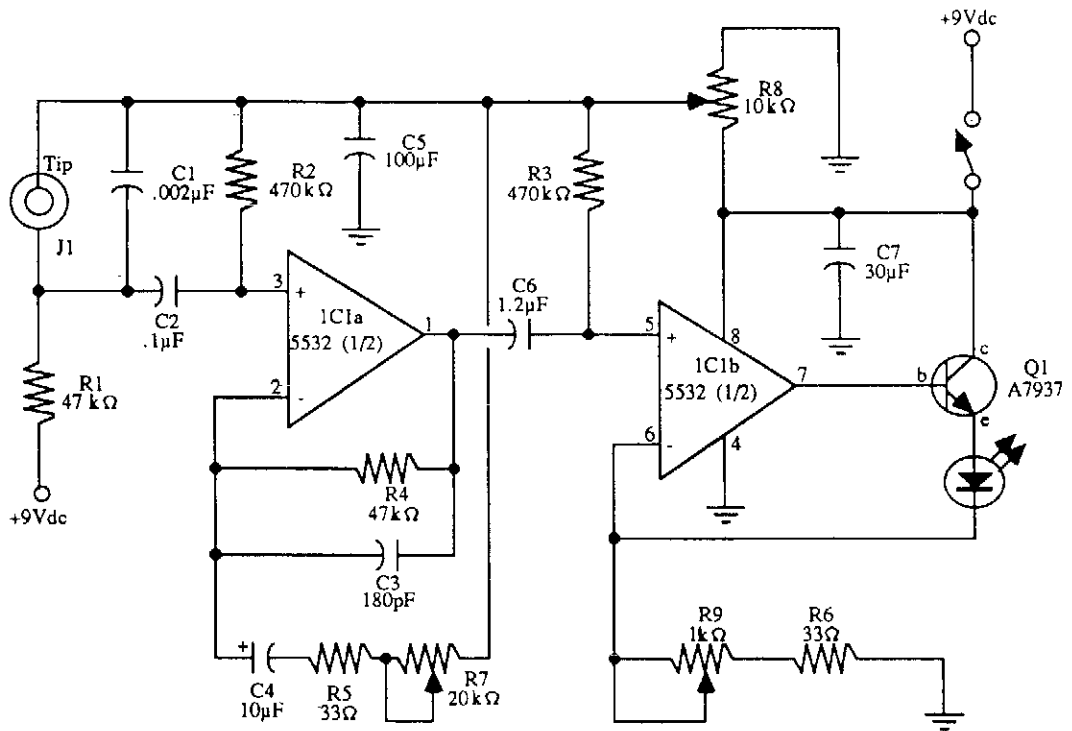

- | | |
|--------|--|
| R1, R4 | 47 kΩ |
| R2, R3 | 470 kΩ |
| R5, R6 | 33 Ω |
| R7, R9 | 1 kΩ potentiometer |
| R8 | 10 kΩ potentiometer |
| C1 | 0.002 μF disc |
| C2 | 0.1 μF disc |
| C3 | 180 pF disc |
| C4 | 10 μF polarized electrolytic |
| C5 | 100 μF polarized electrolytic |
| C6 | 1.2 μF polarized electrolytic |
| C7 | 30 μF polarized electrolytic |
| IC1 | 5532 low-noise amplifier IC |
| Q1 | A7937 transistor |
| LED1 | High-output LED (see text) |
| J1 | Miniature phone jack (for electret condenser microphone) |
| S1 | SPST switch |

All resistors are 5 to 10 percent tolerance, 1/4 watt. All capacitors are 10 to 20 percent tolerance, rated at 35 volts or more.

LED LIGHTWAVE RECEIVER

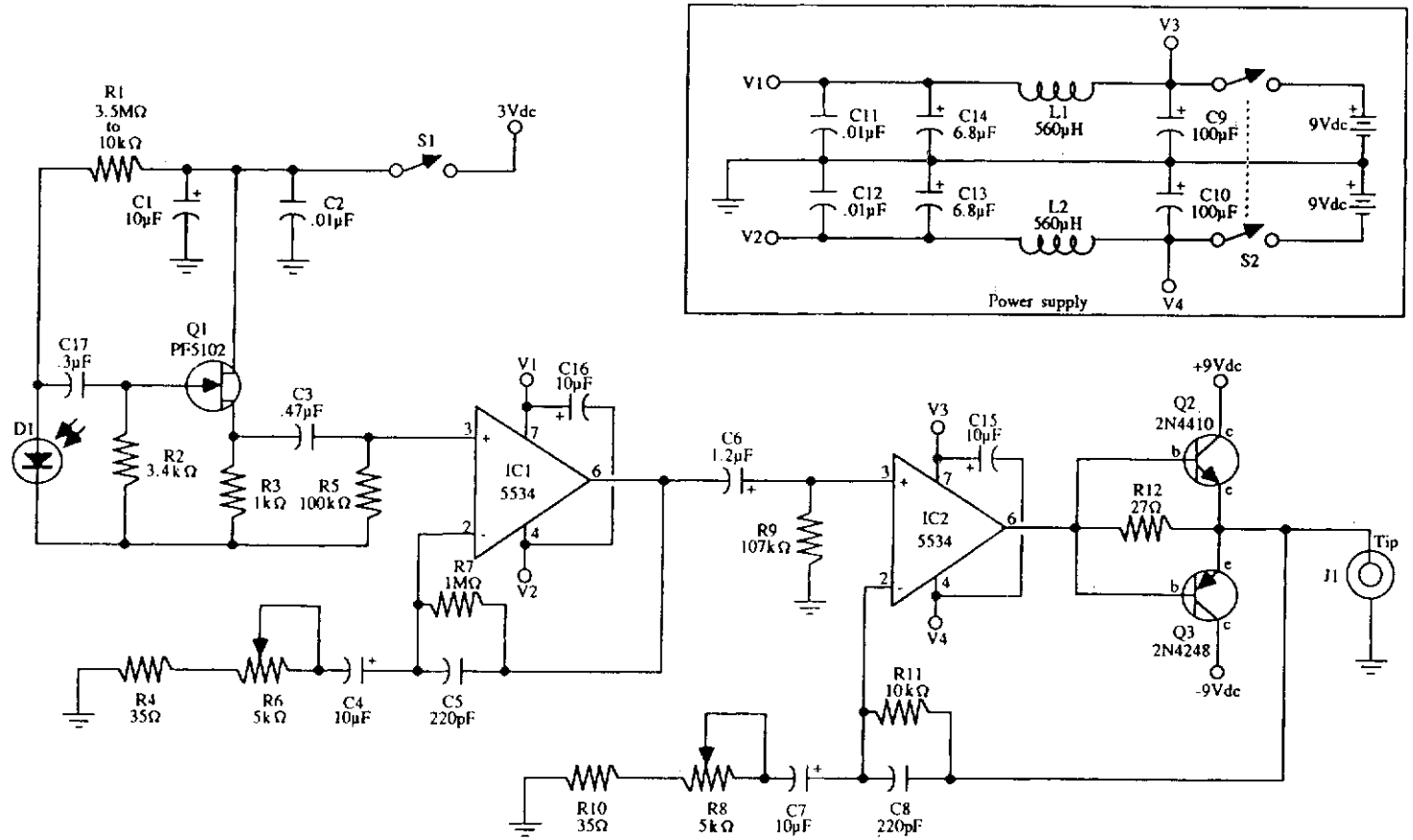

SOLAR POWER SUPPLY

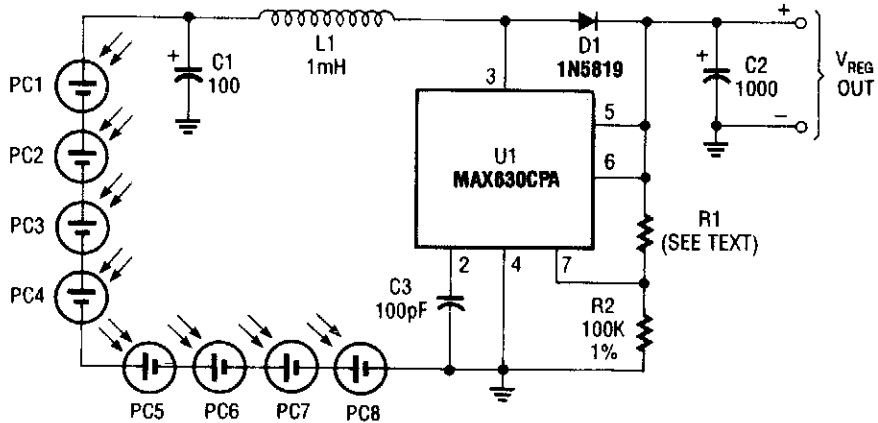

ELECTRONICS HOBBYIST HANDBOOK

Fig. 47-17

This circuit delivers either 4.8 or 7.2 V regulated at 15 mA with a 3-V input from a bank of photocells. R1 should be 453 kΩ for a 7.2-V output and 274 kΩ for a 4.8-Vdc output. Regulator efficiency is around 70%. This should be considered when selecting suitable solar cells.

SOLAR POWER SUPPLY WITH LINEAR REGULATOR

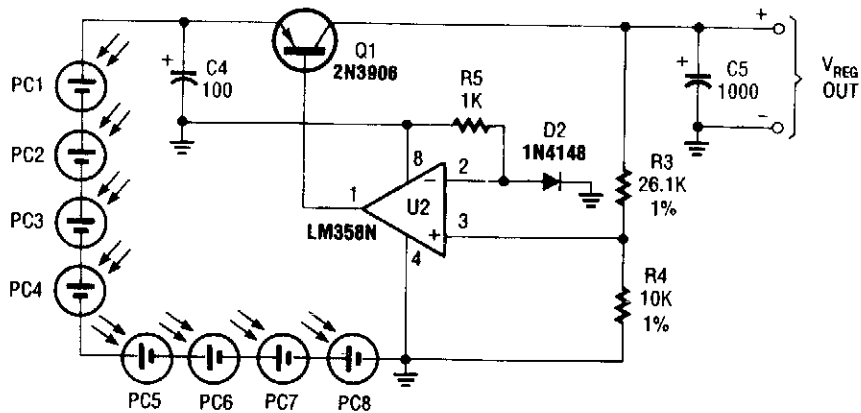

ELECTRONICS HOBBYIST HANDBOOK

Fig. 47-18

This regulator delivers a constant 2.4 Vdc for powering small devices that run on two AA cells, such as cassettes and small radios. Regulator drop is about 0.3 volt. This should be considered when choosing solar cells. Load current is typically 125 mA.

PHOTODIODE LOG CONVERTER/TRANSMITTER

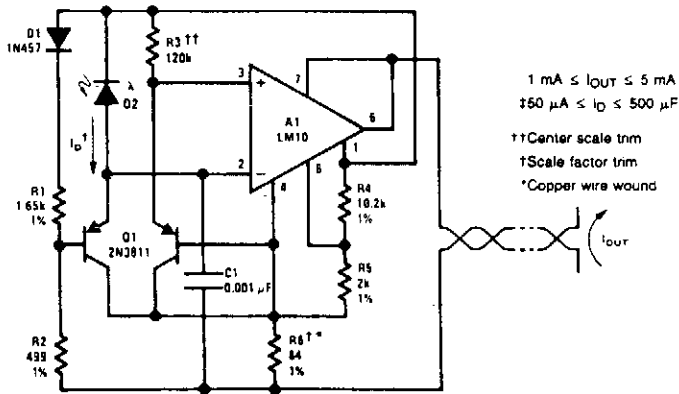

NATIONAL SEMICONDUCTOR

Fig. 47-19

A logarithmic conversion is made on the output current of a photodiode to compress a four-decade, light-intensity variation into a standard transmission range. The circuit is balanced at mid-range, where R3 should be chosen so that the current through it equals the photodiode current. The log-conversion slope is temperature compensated with R6. Setting the reference output to 1.22 V gives a current through R2 that is proportional to absolute temperature because of D1 so that this level-shift voltage matches the temperature coefficient of R6. C1 has been added so that large-area photodiodes with high capacitance do not cause frequency instabilities.

RECHARGEABLE SOLAR POWER FOR SUN TRACKER

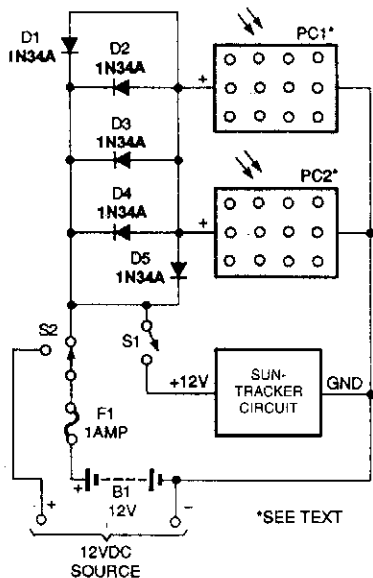

This application circuit provides rechargeable solar power for the sun tracker, as well as for another 12-volt device. PC1 and PC2 can be mounted on sun tracker assembly.

POPULAR ELECTRONICS

Fig. 47-20

48

Logic Circuits

The sources of the following circuits are contained in the Sources section, which begins on page 707. The figure number in the box of each circuit correlates to the entry in the Sources section.

Logic State Change Indicator
Combinatorial Logic Multiplexer
AND Gate
Relay "AND" Circuit
Relay "OR" Circuit

LOGIC STATE-CHANGE INDICATOR

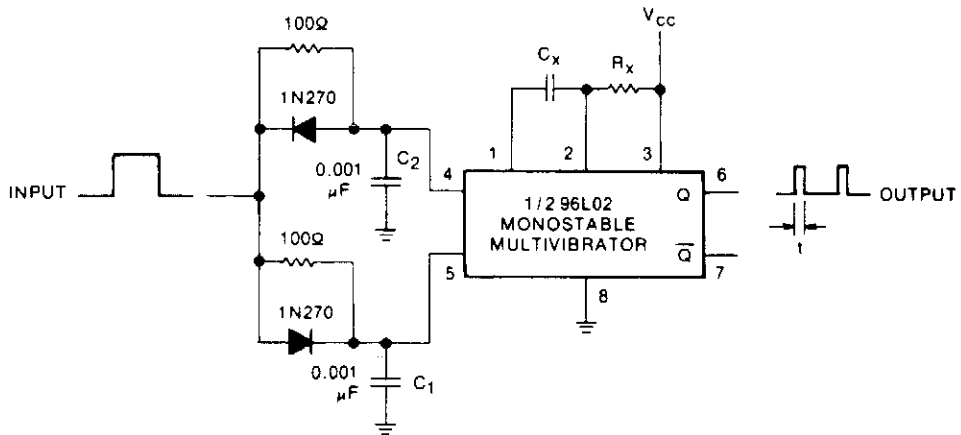

NASA TECH BRIEFS

Fig. 48-1

A circuit consisting of a one-shot multivibrator IC, a pair of diodes, and some resistors and capacitors delivers an output pulse when the logic state at its input terminal changes—either from high to low or from low to high. Thus, this circuit can serve as a state-change indicator or as a frequency doubler for a square-wave input.

Any monostable can be used; the arrangement in the figure achieves low power dissipation (80 milliwatts) by using half of a Fairchild 96L02 transistor-transistor-logic dual multivibrator. The 96L02 is triggered when pins 3 and 5 are high and pin 4 changes state from low to high. It also triggers if pin 3 is high, pin 4 is low.

The circuit shown here allows these conditions to be satisfied with a single input terminal, plus the fixed bias on pin 3; the arrangement of resistors, capacitors, and diodes automatically biases pin 5 high when transmitting a rising transition to pin 4 and biases pin 4 low when applying a falling transition to pin 5.

For example, if the input terminal has been low and then goes high, C1 charges through a forward-biased diode that shunts its 100-Ω resistor; therefore pin 5 goes high immediately. C2 charges through 100 Ω; however, because its diode is back-biased, the rising level is not applied to pin 4 until 5 is already high. Therefore, the conditions for triggering an output pulse are satisfied.

The output pulse duration, t , is set by the value of time constant $R_x C_x$.

COMBINATORIAL LOGIC MULTIPLEXER

TRUTH TABLE			
C	B	A	Function out
0	0	0	0
0	0	1	1
0	1	0	0
0	1	1	1
1	0	0	1
1	0	1	1
1	1	0	0
1	1	1	0

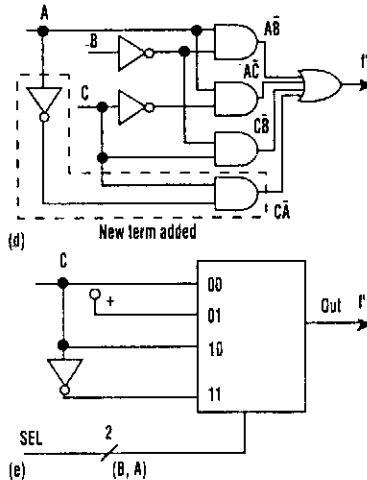
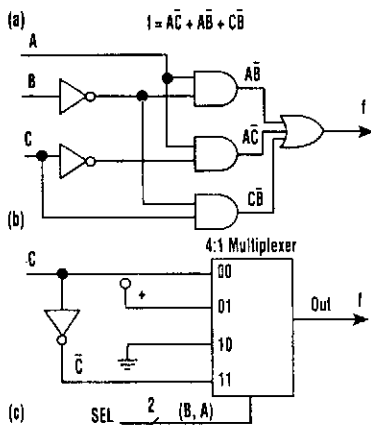

ELECTRONIC DESIGN

Fig. 48-2

Combinatorial logic can be implemented simply by using a multiplexer instead of logic gates. Shown are the truth table (A), its logic circuit (B), and the multiplexer connections (C). If the logic circuitry is changed (D), the multiplexer would be reconnected (E).

AND GATE

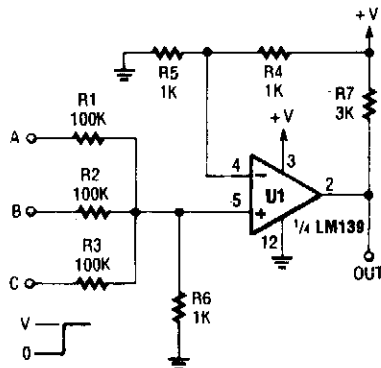

POPULAR ELECTRONICS

Fig. 48-3

An LM139 is configured as an AND gate. (TTL or CMOS is usually used). With this idea, you can use leftover IC sections and save an extra package in some instances.

RELAY "AND" CIRCUIT

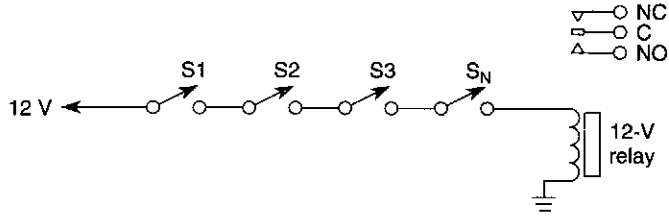

WILLIAM SHEETS

Fig. 48-4

All switches S_1 through S_n must be closed to operate the relay. If one opens, the relay drops out. Use this circuit for burglar alarms, etc.

RELAY "OR" CIRCUIT

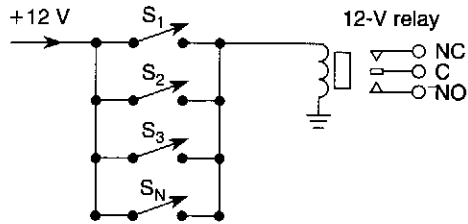

WILLIAM SHEETS

Fig. 48-5

Closing any switch S_1 , S_2 , S_3 , or S_n will actuate the relay ($N = \text{any number}$). Use this circuit for burglar alarms, etc.

49

Mathematical Circuits

The sources of the following circuits are contained in the Sources section, which begins on page 707. The figure number in the box of each circuit correlates to the entry in the Sources section.

- Low-Cost One-Quadrant Multiplier/Divider
- Low-Cost Accurate Square-Root Circuit
- Low-Cost Accurate Squaring Circuit
- Bridge Linearizing Function
- Square Rooter
- Analog Variable Multiplier/Divider
- Difference of Squares
- Approximation for $\sin \phi$
- Simple Analog Averaging Circuit
- Simple Analog Multiplier
- $\Delta\%$ Ratio Computer

LOW-COST ONE-QUADRANT MULTIPLIER/DIVIDER

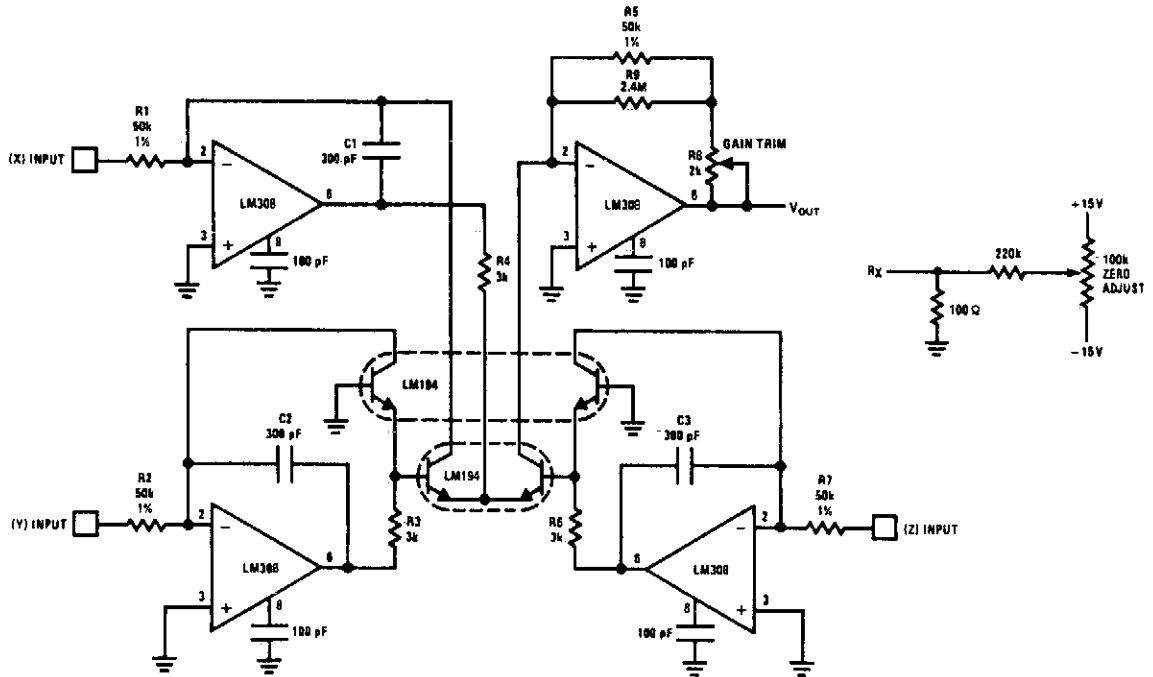

NATIONAL SEMICONDUCTOR

Fig. 49-1

This circuit will produce an output that is proportional to the product of the (X) and (Y) inputs divided by the Z input. All inputs must be positive, limiting operation to one quadrant. For very low level inputs, the offset voltage in the LM308s might create large percentage errors referred to input. A simple scheme for offsetting any of the LM308s to zero is shown in dotted line; the positive input of the appropriate LM308 is simply tied to R_x instead of ground for zeroing. The summing mode of operation on all inputs allows easy scaling on any or all inputs. Simply set the input resistor equal to $(V_{in(max)})/(200 \mu A)$. V_{out} is equal to:

$$V_{out} = \frac{\left(\frac{X}{R_1}\right)\left(\frac{Y}{R_2}\right)(R_5)}{\frac{Z}{R_7}}$$

Input voltages above the supply voltage are allowed because of the summing mode of operation. Several inputs can be summed at X, Y, and Z.

For a simple $(X) \cdot (Y)$ or $(X)/Z$ function, the unused input must be tied to the reference voltage. Perturbations in this reference will be seen at the output as scale factor changes, so a stable reference is necessary for precision work. For less critical applications, the unused input can be tied to the positive supply, with

$$R = \frac{V_+}{200 \mu A}$$

LOW-COST ACCURATE SQUARE-ROOT CIRCUIT

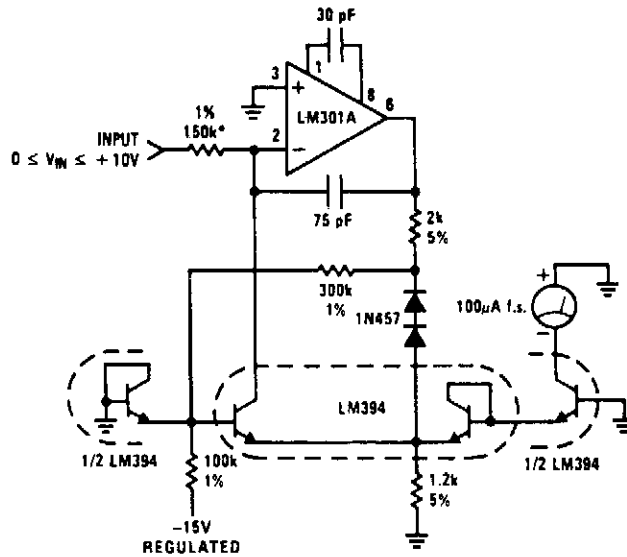

*Trim for full scale accuracy.

NATIONAL SEMICONDUCTOR

Fig. 49-2

The circuit will generate a square-root function, accurately and inexpensively. The output is a current that can be used to drive a meter directly or be converted to a voltage with a summing junction current-to-voltage converter. The -15-V supply is used as a reference, so it must be stable. A 1% change in the -15-V supply will give a $\frac{1}{2}\%$ shift in output reading. No positive supply is required when an LM301A is used because its inputs can be used at the same voltage as the positive supply (ground). The two 1N457 diodes and the $300\text{-k}\Omega$ resistor are used to temperature-compensate the current through the diode-connected $\frac{1}{2}\text{LM394}$.

LOW-COST ACCURATE SQUARING CIRCUIT

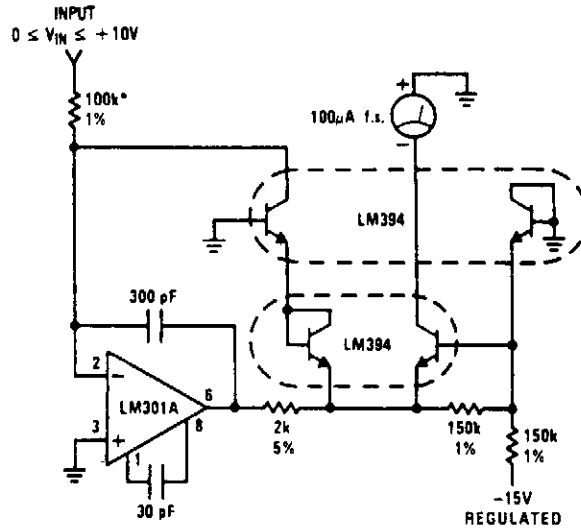

*Trim for full scale accuracy.

NATIONAL SEMICONDUCTOR

Fig. 49-3

The circuit shown will square the input signal and deliver the result as an output current. Full-scale input is 10 V, but this can be changed simply by changing the value of the 100-k Ω input resistor. As in the square root circuit, the -15-V supply is used as the reference. In this case, however, a 1% shift in supply voltage produces a 1% shift in the output signal. The 150-k Ω resistor across the base-emitter of $\frac{1}{2}$ LM394 provides slight temperature compensation of the reference current from the -15-V supply. For improved accuracy at low input signal levels, the offset voltage of the LM301A should be zeroed out, and a 100-k Ω resistor should be inserted in the positive input to provide optimum dc balance.

BRIDGE LINEARIZING FUNCTION

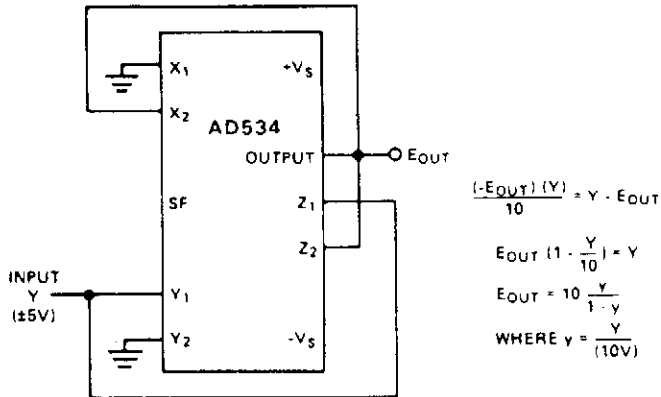

ANALOG DEVICES

Fig. 49-4

If one arm of a Wheatstone Bridge varies from its nominal value by a factor, $(1 + 2x)$, the voltage or current output of the bridge will be (with appropriate polarities):

$$y \approx \frac{x}{1 + x}$$

Linear response requires very small x and, usually, preamplification. The circuit shown here enables large-deviation bridges to be used without losing linearity.

The circuit computes the inverse of the bridge function, i.e.,

$$x \approx \frac{y}{1 + y}$$

Depending on which arm of the bridge varies, it might be necessary to reverse the polarity of the z connections.

SQUARE ROOTER

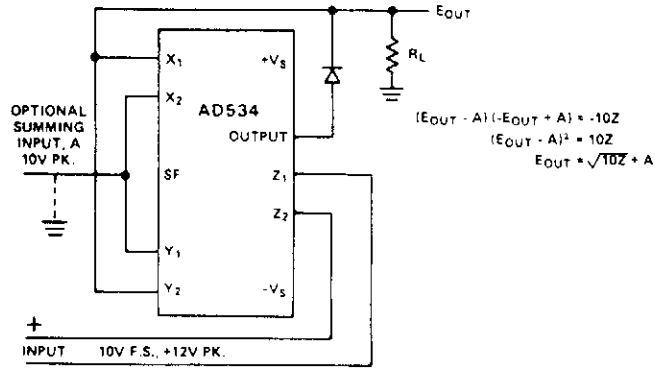

ANALOG DEVICES

Fig. 49-5

This illustration shows the connection of the AD534 for square-rooting, with differential inputs. The diode prevents a latching condition—common to this configuration—which would occur if the input momentarily changed polarity. As shown, the output is always positive; it can be changed to a negative output by reversing the diode polarity and interchanging the X inputs. Because the signal input is differential, all combinations of input and output polarities can be realized. If the output circuit does not provide a resistive load to ground, one should be connected to maintain diode conduction. For critical applications, the Z offset can be adjusted for greater accuracy below 1 V.

ANALOG VARIABLE MULTIPLIER/DIVIDER

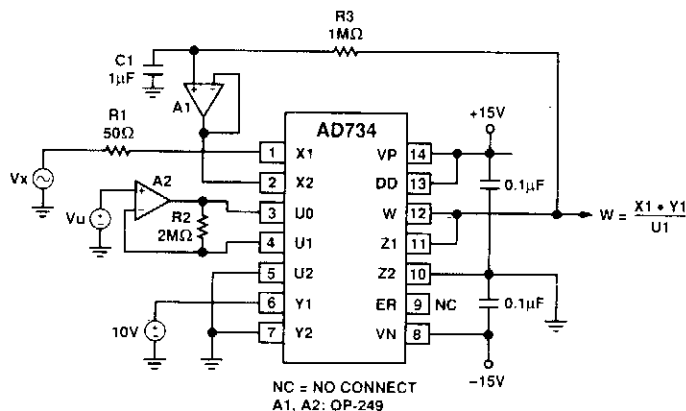

ANALOG DEVICES

Fig. 49-6

An output voltage ($W = X_1 \times Y_1 / U_1$) is produced by this multiplier circuit. The AD734 is a four-quadrant multiplier.

DIFFERENCE OF SQUARES

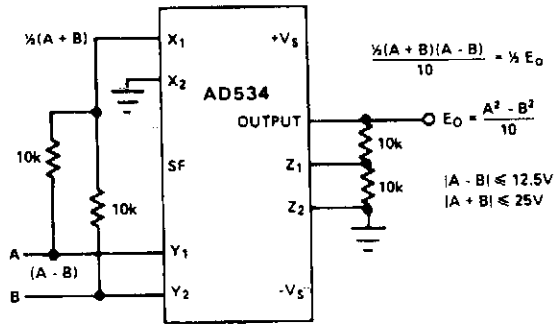

ANALOG DEVICES

Fig. 49-7

A single AD534 can be used to compute the difference of the squares of two input signals. The function can be useful in vector computations, and in weighting the difference of two magnitudes to emphasize the greater nonlinearity.

APPROXIMATION FOR SIN ϕ

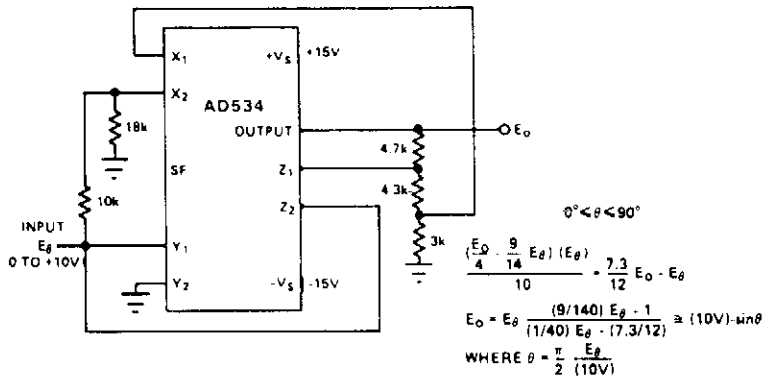

ANALOG DEVICES

Fig. 49-8

The AD534 is remarkably easy to use in the implementation of the approximation formulas described in Chapter 2-1 of the *Nonlinear Circuits Handbook*. Many of these involve implicit loops to generate the function and previously required several additional op amps for the addition and subtraction of the various terms. This circuit is an example of what can be done with external resistors only. For ϕ between 0° and 90° , the approximation maintains a theoretical accuracy to within 0.5% of full-scale; 0.75% is practical with AD534L and 0.1% resistances were used.

SIMPLE ANALOG AVERAGING CIRCUIT

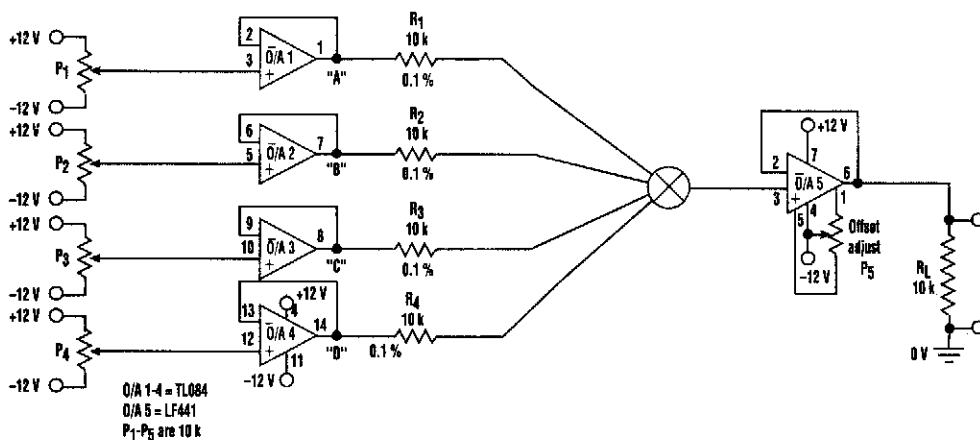

Voltage at points	TABLE								
	"A"	+5	+5	-5	+1.5	-1	+8	+10	+10
"B"	+5	-5	-5	-3	-3	+8	+10	-9	
"C"	+5	+5	+5	-6	-5	-3	+10	+10	
"D"	+5	+5	+5	+2.5	-8	+9	+9	+10	
Output across R _L	+5	+2.5	0	-1.25	-4.25	+5.5	+9.75	+5.25	

ELECTRONIC DESIGN

Fig. 49-9

At times, an analog circuit that averages rather than sums can be quite handy. You won't usually find this type of circuit in op-amp books, possibly because the op amp is used only as a buffer. For best accuracy, an FET should be used with the offset adjusted out. In addition, the "averaging" resistors (R1 through R4) should be of close tolerance.

Looking at the test circuit, op amps 1 through 4 are used to alleviate interaction between adjustment potentiometers P1 through P4 and so that R1 through R4 see the same low impedance.

The table shows some arbitrarily set voltages and the resulting output voltage across R_L.

SIMPLE ANALOG MULTIPLIER

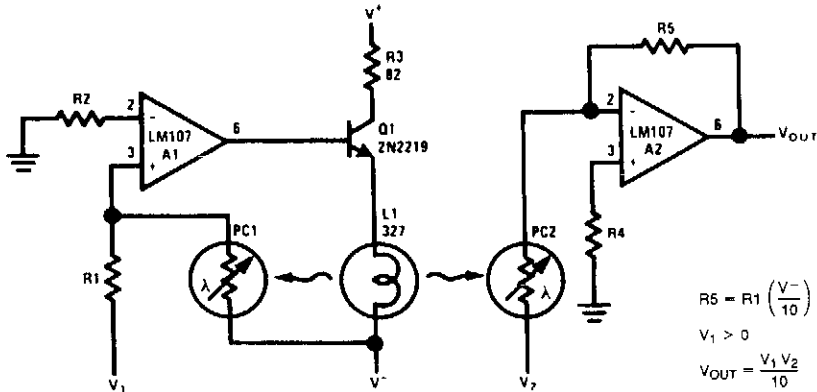

NATIONAL SEMICONDUCTOR

Fig. 49-10

Circuit operation can be understood by considering A2 as a controlled-gain amplifier, amplifying V_2 , whose gain depends on the ratio of the resistance of PC2 to R5 and by considering A1 as a control amplifier, which establishes the resistance of PC2 as a function of V_1 . In this way, V_{OUT} is a function of both V_1 and V_2 .

A1, the control amplifier, provides drive for the lamp, L1. When an input voltage, V_1 , is present, L1 is driven by A1 until the current to the summing junction from the negative supply through PC1 is equal to the current to the summing junction from V_1 through R1. Because the negative supply voltage is fixed, this forces the resistance of PC1 to a value that is proportional to R1 and to the ratio of V_1 to V_- . L1 also illuminates PC2 and, if the photoconductors are matched, causes PC2 to have a resistance equal to PC1.

A2, the controlled gain amplifier, acts as an inverting amplifier whose gain is equal to the ratio of the resistance of PC2 to R5. If R5 is chosen equal to the product of R_1 and V_- , then V_{OUT} becomes simply the product of V_1 and V_2 . R5 can be scaled in powers of 10 to provide any required output scale factor.

Δ% RATIO COMPUTER

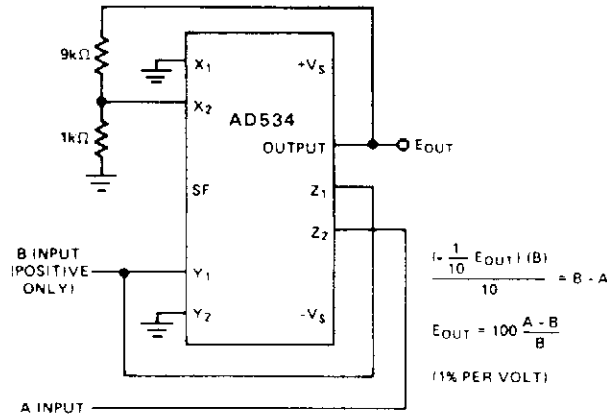

ANALOG DEVICES

Fig. 49-11

The percentage-deviation function is of practical value for many applications in measurement, testing, and control. For example, the output of this circuit might be applied to a pair of biased comparators to stimulate particular actions or displays, depending on whether the gain of a circuit under test were within limits, or deviating by a preset amount in either direction.

The indicated scale factor, 1%/V, is convenient. However, other sensitivities, from 10%/V to 0.1%/V, as required by the application, can be obtained by altering the feedback attenuation ratio, from 1 to 1/100. Gain or attenuation is easily applied to the A signal externally for calibration to the normalized form.

50

Measuring and Test Circuits

The sources of the following circuits are contained in the Sources section, which begins on page 707. The figure number in the box of each circuit correlates to the entry in the Sources section.

Electronic Level
Single-Chip Digital Voltmeter
Inductance with DVM Measuring Circuit
Negative Reference Voltage Circuit
Precision Current Source
1-kW Power Meter
Logic Chip Tester
Power Supply for 10-MHz Frequency Standard
Three-Terminal Regulator Current Source
Four-Wire Resistance Measurement Hookup
Audio Frequency Meter
ELF Monitor
Strain-Gage Sensor
Minute Marker
Digital Barometer
Reference Circuit
Transistor Matching Circuit
Auto-Ranging Digital Capacitance Meter
Frequency Divider for 10-MHz Frequency Standard
Electroscope
Optical Isolator Wattmeter
Digital Three-Phase Wave Generator
Simple Test Audio Amplifier
Gate Dip Oscillator I
Accelerometer (G Meter) Circuit
Gate Dip Oscillator II
Two Remote Meters
Novel RF Power Meter
Nanoammeter
1.5-V Logarithmic Light Level Meter
ac Power Monitor
100-W Variable Resistor Simulator
IMD Test Circuit for Pin Diodes
VCO and Input Frequency Comparer
ECG Amplifier with Right Leg Drive
Power Transformer Tester
4- to 20-mA Process Controller
Simple High-Current Measurer
Analog Circuitry Calibrator
Simple Signal Generator for Signal Tracing
Simple Harmonic Distortion Analyzer
Sound Subcarrier Generator
Inductance and Capacitance Determiner
with SWR Bridge
Motorcycle Tune-Up Aid
50-MHz Frequency Counter
10-MHz Frequency Standard
Programmable Capacitor Circuit
Programmable Resistor Circuit

ELECTRONIC LEVEL

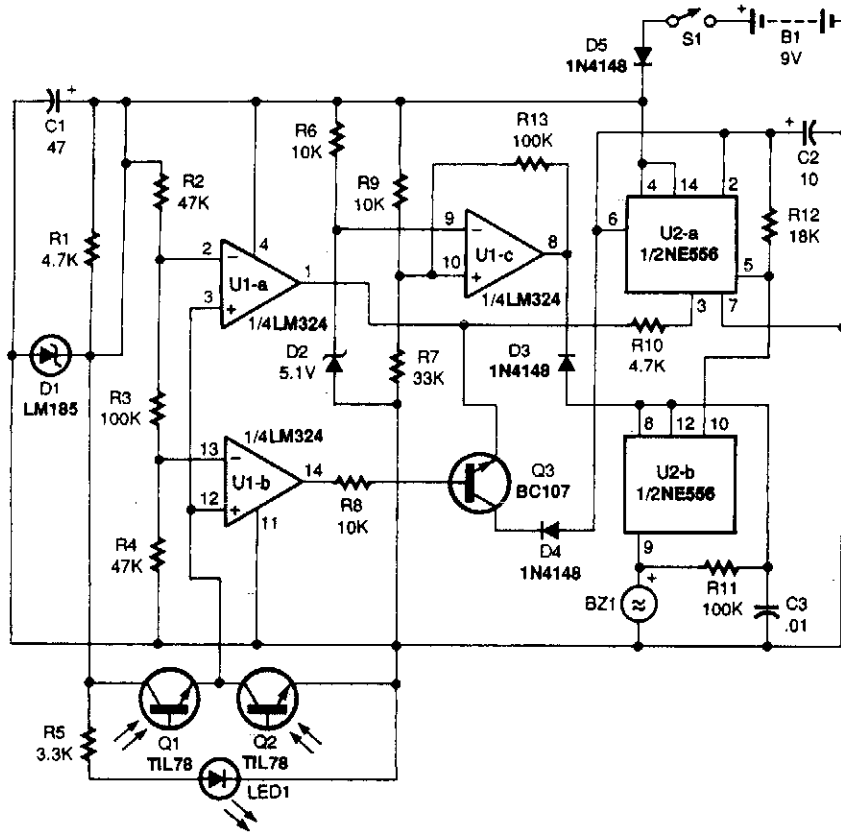

POPULAR ELECTRONICS

Fig. 50-1

The electronic level uses a pair of phototransistors and an infrared LED to sense bubble position. In this circuit, the amounts of infrared radiation received by phototransistors Q1 and Q2 are translated by op-amp U1 and dual-timer U2 into either a steady tone, or a fast- or slow-pulsing one.

SINGLE-CHIP DIGITAL VOLTMETER

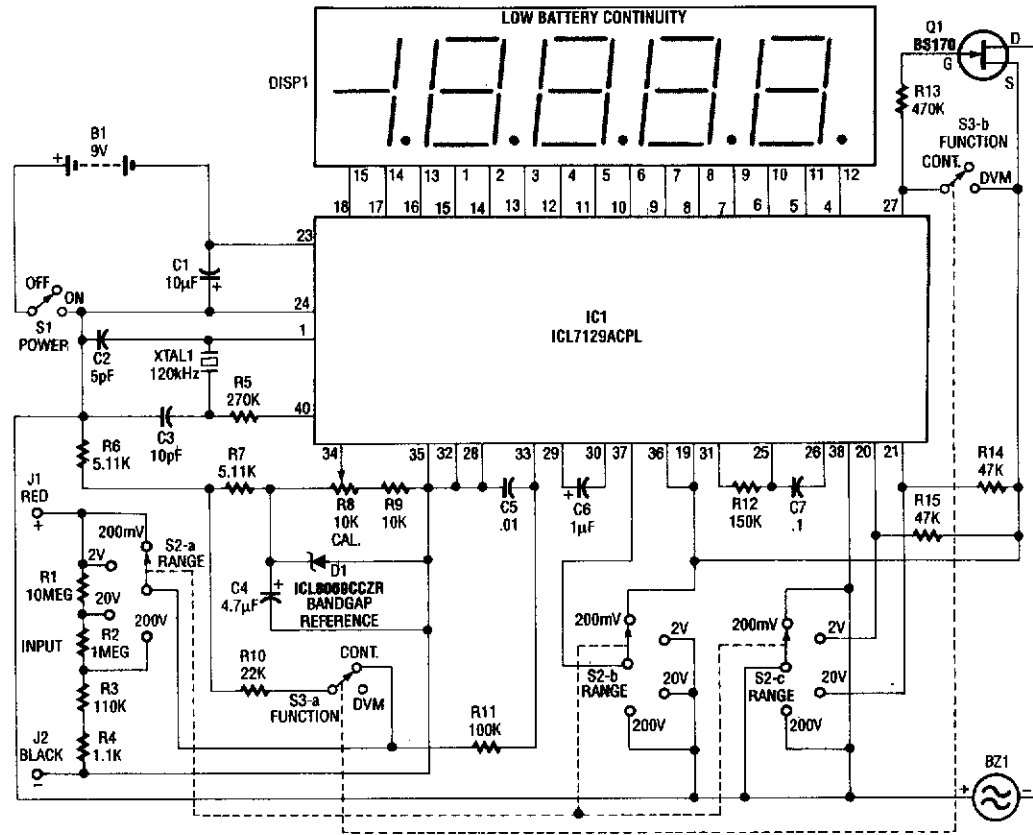

ELECTRONIC EXPERIMENTERS HANDBOOK

Fig. 50-2

This 4½-digit DVM circuit is built around a Maxim ICL7129ACPL A/D converter and LCD driver. An ICL8069 CCZR 1.2-V band-gap reference diode is used for a voltage reference. S2a-b-c select one of four ranges up to 200 V (maximum). The meter also has a piezoelectric buzzer for continuity testing. S3 selects either DVM or continuity. Crystal 1 can be changed to 100 kHz if maximum rejection of 50 Hz is desired. The crystal normally provides 120 kHz for best 60-Hz rejection. This is caused by the dual-slope conversion technique used in IC1.

INDUCTANCE WITH DVM MEASURING CIRCUIT

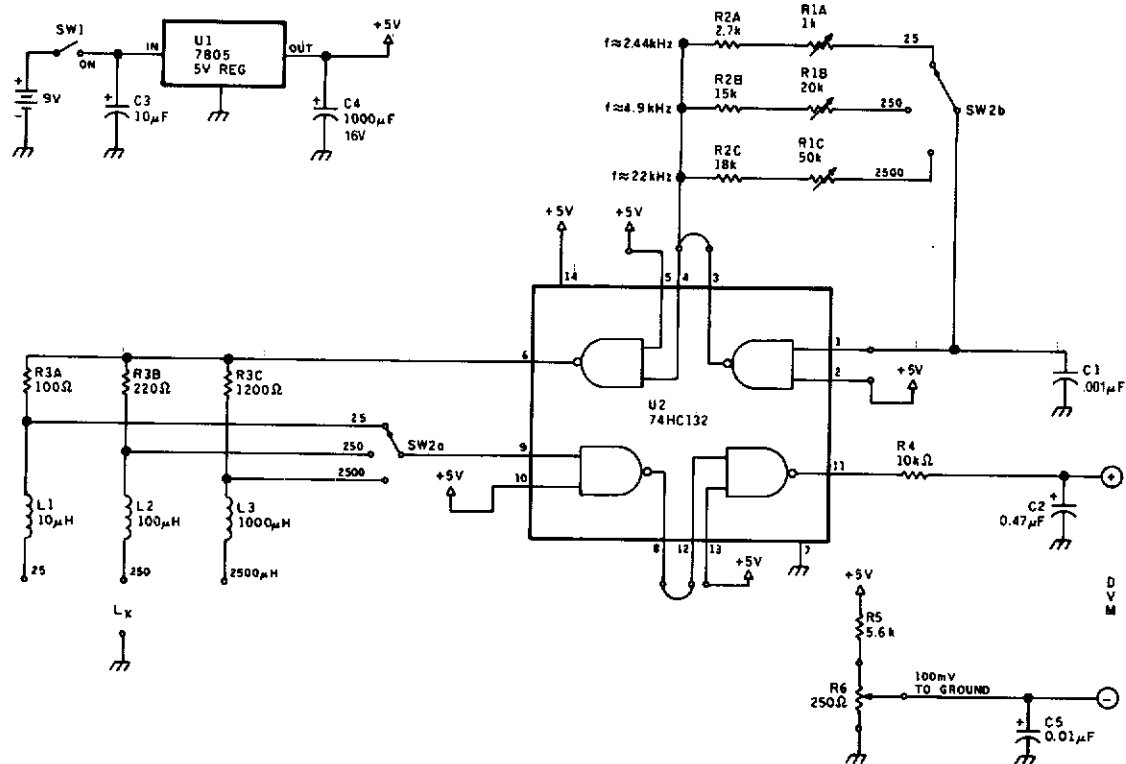

The inductance meter comprises an oscillator and pulse shaper. The square wave from the oscillator is differentiated and the differentiator output is shaped and read on a DVM. This will be proportional to inductance. R1A, B, C set calibration and R6 is an offset control.

NEGATIVE REFERENCE VOLTAGE CIRCUIT

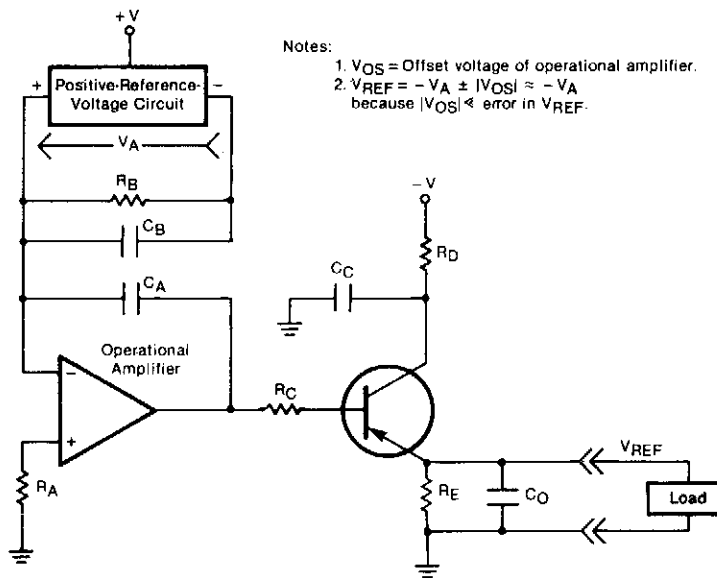

NASA TECH BRIEFS

Fig. 50-4

This figure illustrates a circuit that supplies a precise negative reference voltage. To meet requirements of accuracy and stability, it incorporates a highly precise positive reference voltage by use of a high-gain, stable feedback booster circuit.

The booster circuit includes an operational amplifier and a transistor, which handles the load current. Typically, a positive-reference-voltage circuit can handle only relatively small load currents. This consideration does not apply in the present circuit because the positive-reference-voltage unit is placed in the voltage feedback loop of the booster circuit in parallel with resistor R_B . Thus, from the perspective of the positive-reference-voltage unit, R_B is a constant load. This feature enhances the stability of the circuit by removing the load regulation factor.

Provided that the offset voltage of the operational amplifier is low, the accuracy of the overall circuit depends only on the accuracy of the positive-reference-voltage unit. The overall circuit draws very little power for its own operation. It can handle unexpectedly heavy loads; the feedback configuration and the high gain provided by the combination of the operational amplifier and the transistor give the circuit a very low output impedance. The capacitors reduce the noise voltage and help stabilize the circuit. In the event that the load becomes a short circuit, R_D protects the transistor by limiting the load current.

PRECISION CURRENT SOURCE

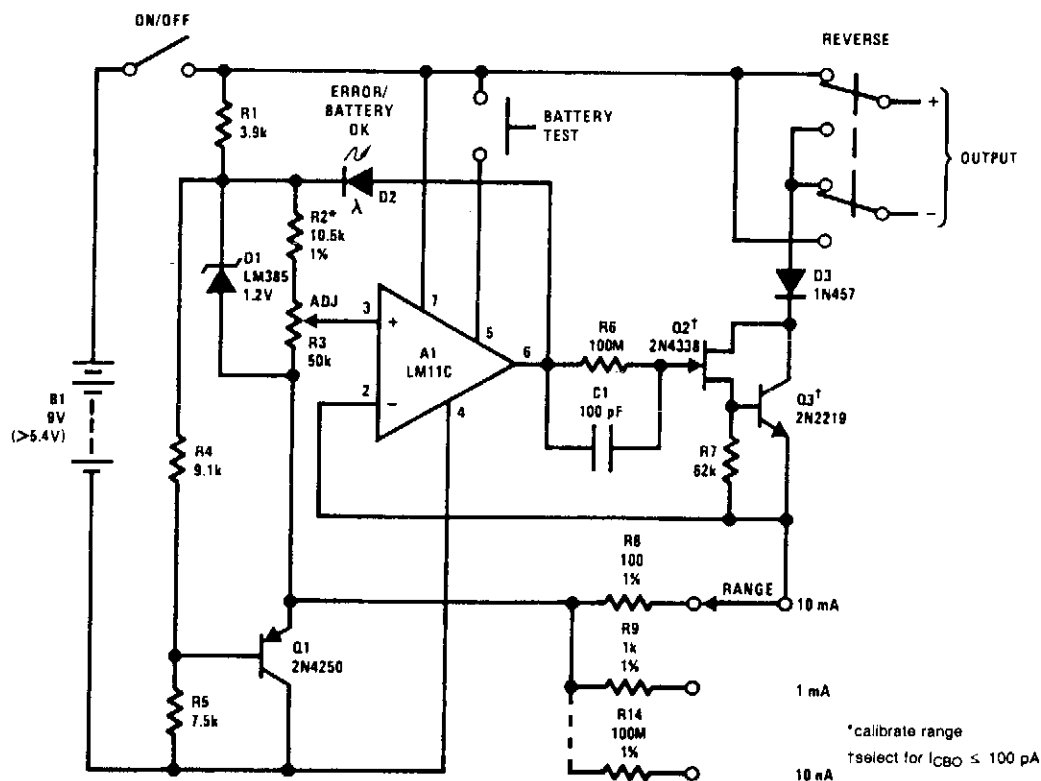

NATIONAL SEMICONDUCTOR

Fig. 50-5

A complete, battery-powered current source suitable for laboratory use is shown. The op amp regulates the voltage across the range resistors at a level determined by the voltage on the arm of the calibrated potentiometer, R3. The voltage on the range resistors is established by the current through Q2 and Q3, which is delivered to the output.

The reference diode, D1, determines basic accuracy. Q1 is included to ensure that the LM11 inputs are kept within the common-mode range with diminishing battery voltage. A light-emitting diode, D2, is used to indicate output saturation. However, this indication cannot be relied upon for output-current settings below about 20 nA, unless the value of R6 is increased. The reason is that very low currents can be supplied to the range resistors through R6 without developing enough voltage drop to turn on the diode.

If the LED illuminates with the output open, there is sufficient battery voltage to operate the circuit. But a battery test switch is also provided. It is connected to the base of the op-amp output stage and forces the output toward V+.

1-kW POWER METER

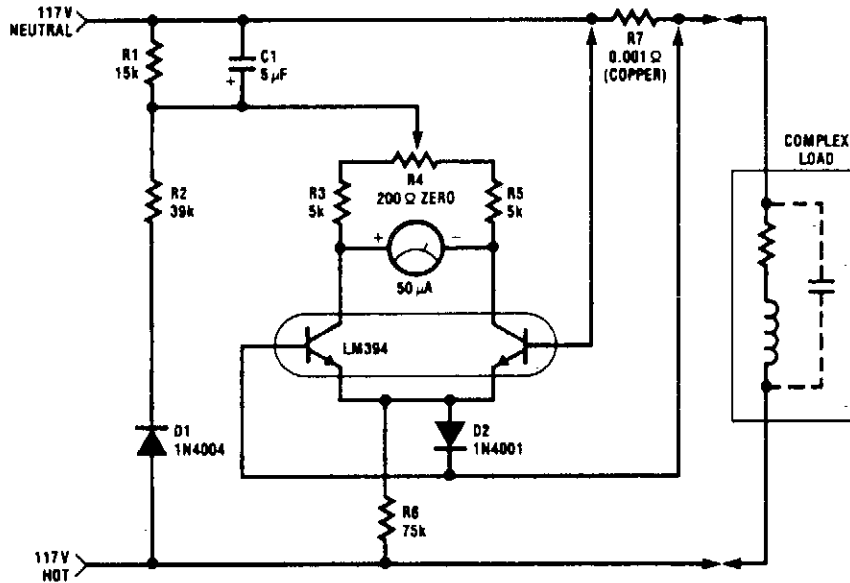

NATIONAL SEMICONDUCTOR

Fig. 50-6

The power meter shown uses only one transistor pair to provide the complete (X) (Y) function. The circuit is intended for 117 Vac \pm 50 Vac operation, but can be easily modified for higher or lower voltages. It measures true (nonreactive) power being delivered to the load and requires no external power supply. Idling power drain is only 0.5 W. The load current-sensing voltage is only 10 mV, keeping load voltage loss to 0.01%. Rejection of reactive load currents is better than 100:1 for linear loads. Nonlinearity is about 1% full scale when using a 50- μ A meter movement. The temperature correction for gain is accomplished by using a copper shunt (+0.32%/°C) for load-current sensing. This circuit measures power on negative cycles only, so it cannot be used on rectifying loads.

LOGIC CHIP TESTER

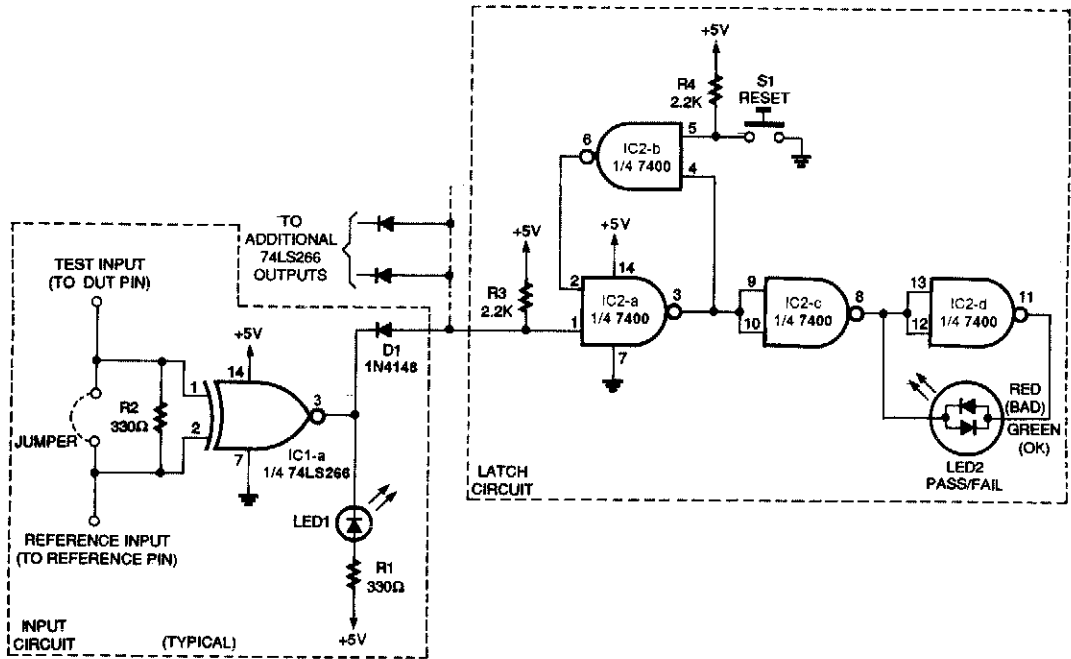

ELECTRONICS NOW

Fig. 50-7

This device compares two logic signals and indicates whether the two logic signals are the same or different. To use the tester, first connect the test input to the suspect pin of the DUT. Next, connect the reference input to the same pin of an identical reference chip that is known to be good. Push the reset button to begin the test; the green section of the bicolor LED will be illuminated. Any signal on the test device that differs from the one on the reference device will then momentarily light the LED lamp that corresponds to that pin, and also latch on the red section of the bi-color LED. That indicates that the device under test is faulty. If the reference and DUT signals are the same, the DUT is OK, and the green LED will remain lit.

POWER SUPPLY FOR 10-MHz FREQUENCY STANDARD

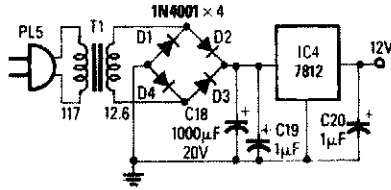

RADIO-ELECTRONICS

Fig. 50-8

This simple power supply can be used in place of battery B1 of the 10-MHz frequency standard.

THREE-TERMINAL REGULATOR CURRENT SOURCE

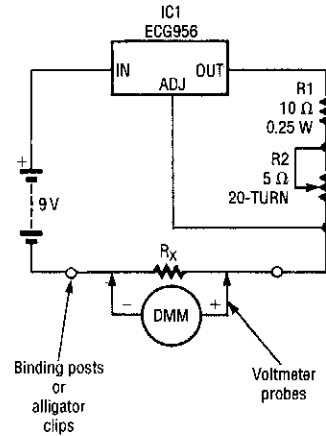

ELECTRONICS NOW

Fig. 50-9

A three-terminal voltage regulator acts as a current source in this circuit. A resistor is being calibrated using a DMM and the current source.

FOUR-WIRE RESISTANCE MEASUREMENT HOOKUP

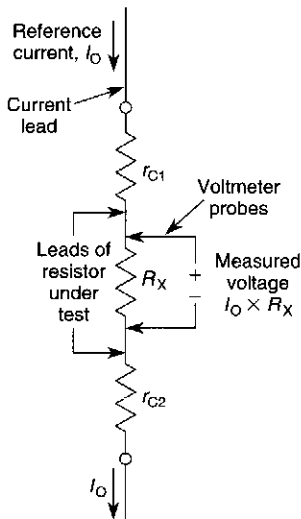

ELECTRONICS NOW

Fig. 50-10

A true four-wire resistance measurement hookup.

AUDIO FREQUENCY METER

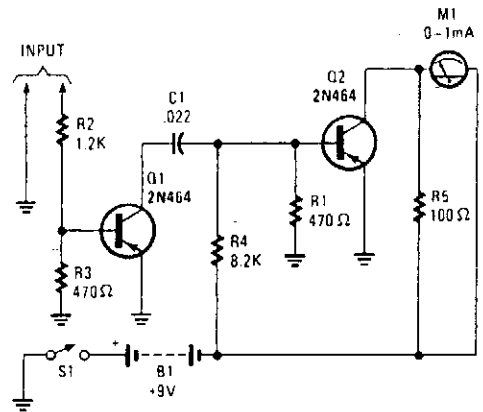

POPULAR ELECTRONICS

Fig. 50-11

A pulse-shaper is used in a tachometer circuit to drive a meter.

ELF MONITOR

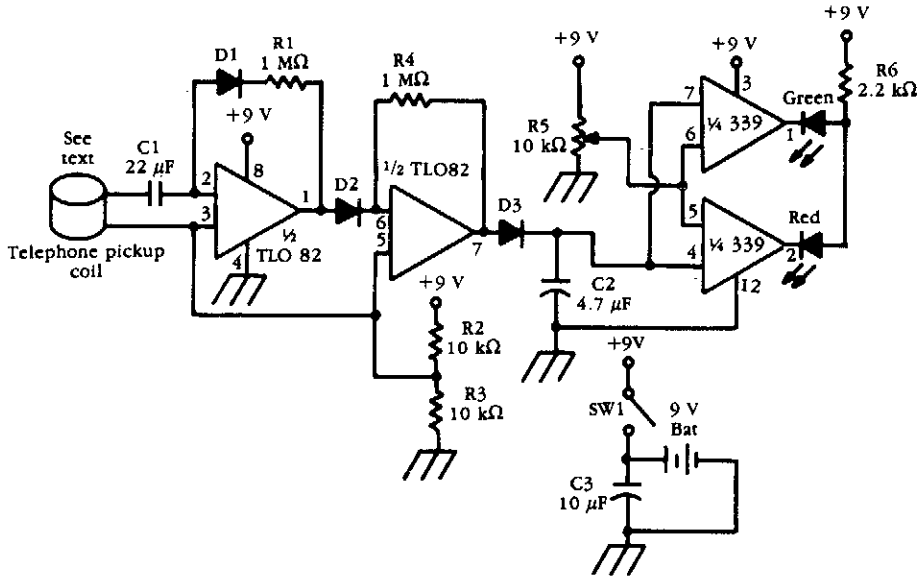

McGRAW-HILL

Fig. 50-12

A telephone pick-up coil is used as a sensor for low-frequency magnetic fields. The signal is amplified and detected, then used to drive a comparator.

STRAIN-GAGE SENSOR

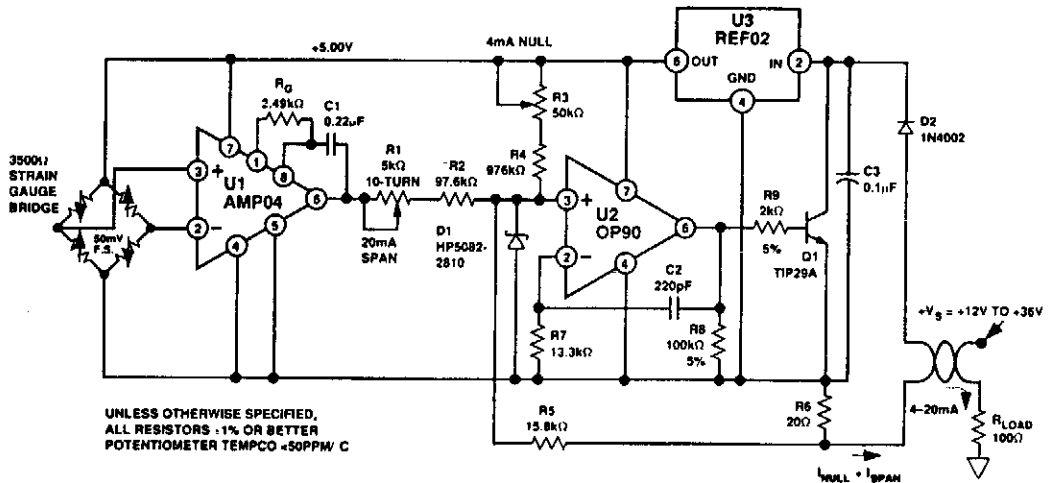

ANALOG DEVICES

Fig. 50-13

In this loop-powered strain-gage sensor application, a 50-mV full-scale (FS) bridge output is amplified and calibrated for a 4-20-mA transmitter output. Power is furnished by the remote loop supply of 12 to 36 V.

MINUTE MARKER

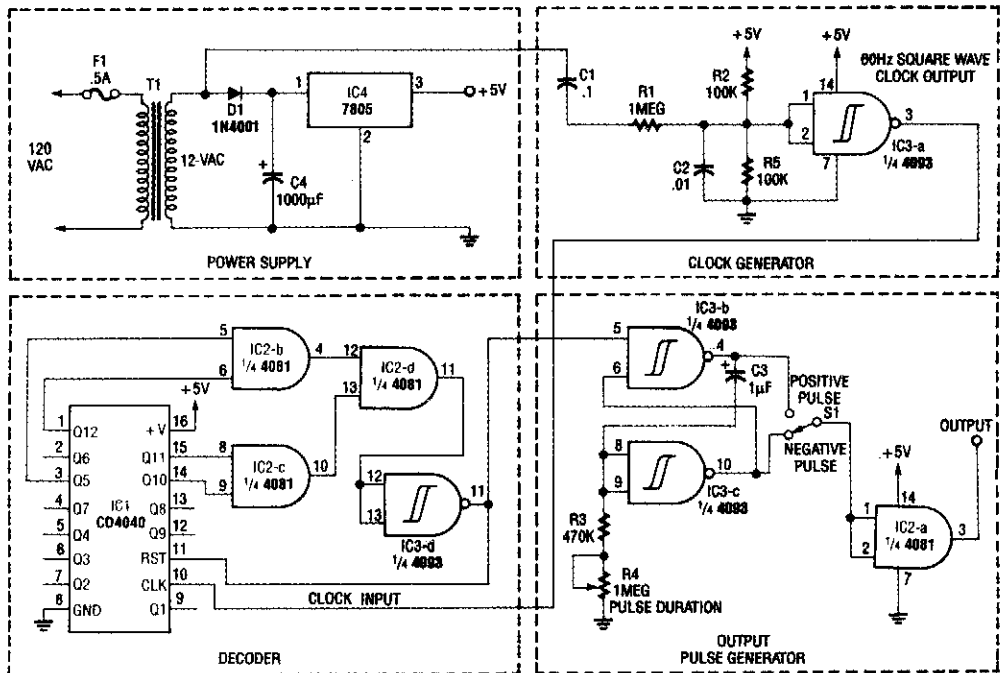

ELECTRONICS NOW

Fig. 50-14

The figure shows the schematic of a minute marker. The output of transformer T1 is 12.6 Vac at 60 Hz, which is rectified by D1 and regulated by IC4, and LM7805 regulator, to provide 5 Vdc for the circuit. The unrectified ac is bandpass-filtered by R1, R2, R5, C1, and C2. Resistors R2 and R5 also form a dc-voltage divider, which biases the input of Schmitt trigger IC3-a to 2.5 V. The Schmitt trigger generates a 60-Hz square wave, which is fed to the input of IC1, a CE4040 12-stage binary counter.

The outputs of the counter are a 4081 quad AND gate (IC2), and the decoded output is fed back to the reset input of the counter, which resets the counter when the desired count is reached.

The pulse from IC2-d is inverted by Schmitt trigger IC3-d, and passed along to the output pulse generator. The output pulse is generated by two Schmitt triggers cross-connected as an RS flip-flop (IC3-b and IC3-c). The output of the flip-flop is fed to 3, R4, and C3, whose values set the output pulse duration. The output pulse duration (T) can be approximated by the formula $T = 1.2 \times C_3 \times (R_3 + R_4)$. A positive or negative-going pulse is selected by S1, and buffered by the remaining AND gate (IC2-a).

DIGITAL BAROMETER

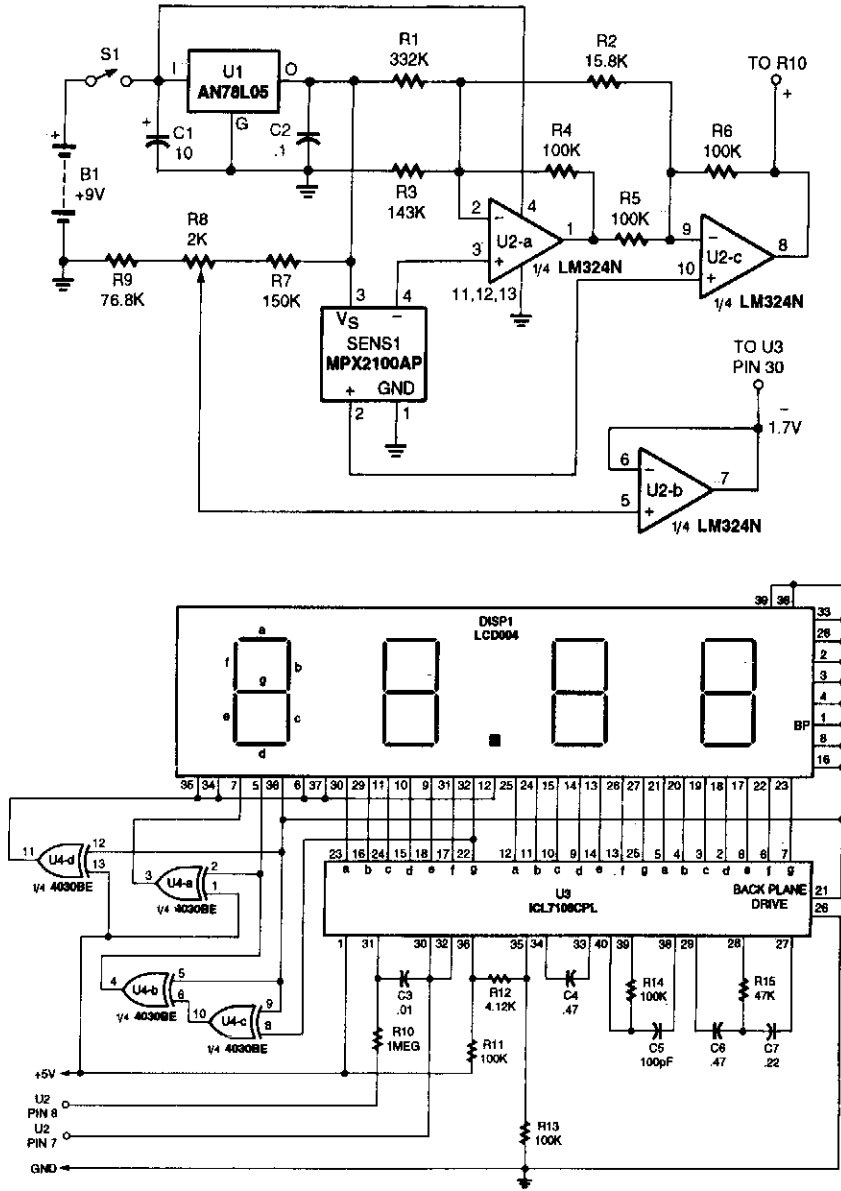

A pressure sensor is used in this application. This outputs a voltage to amplifier U2, and a $3\frac{1}{2}$ digit A/D converter module. It is calibrated to read barometric pressure in inches of mercury.

REFERENCE CIRCUIT

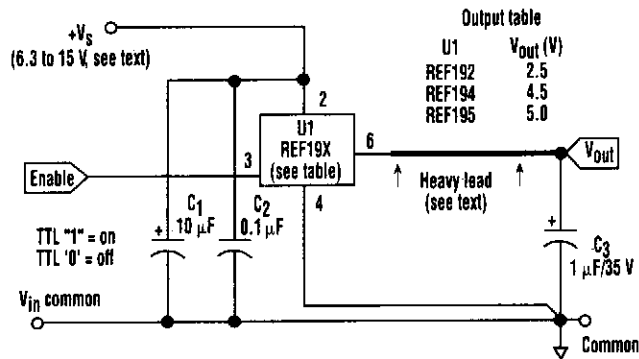

ELECTRONICS DESIGN

Fig. 50-16

In this high-performance reference circuit, U1 is a device from the REF190 series producing device-selectable outputs of 2.5, 4.5, and 5 V with simple, noncritical external circuitry. An Analog Devices REF 19 X (see the table in the figure) is used to derive a reference voltage.

TRANSISTOR MATCHING CIRCUIT

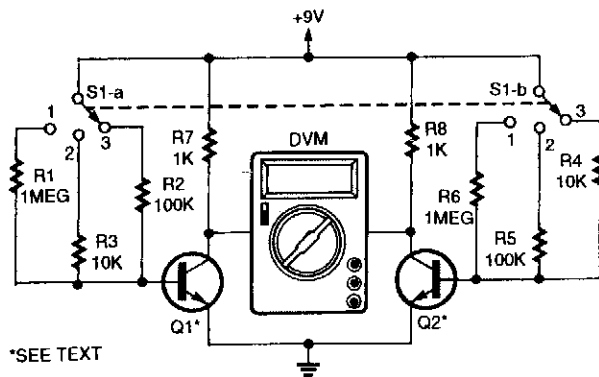

POPULAR ELECTRONICS

Fig. 50-17

In order to match two transistors, select Q1 and Q2 so that they give zero readings (or as close as possible) on a DVM. The DVM acts as a null detector. An analog meter can be substituted. S1 should be set for an appropriate level of base current (approximately 8, 80, or 800 μ A).

AUTO-RANGING DIGITAL CAPACITANCE METER

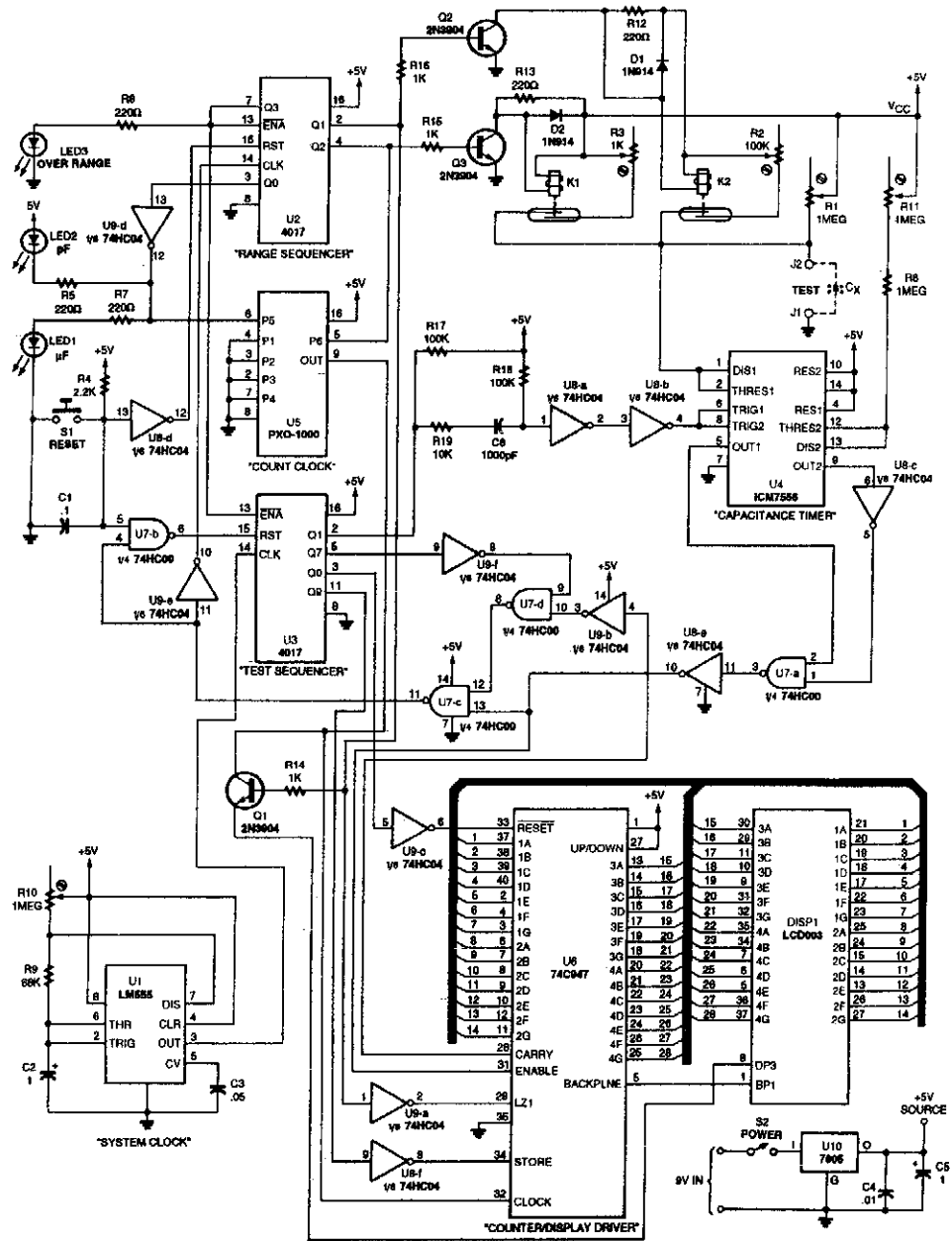

This digital capacitance meter reads from 1 pF to 1000 μF. Basically, a timer (U4) uses the unknown capacitance to generate a pulse of duration, depending on the value of unknown capacitance, and the pulse duration is measured. The display is an LCD 0003 driven by a 74C947 counter/display driver.

FREQUENCY DIVIDER FOR 10-MHz FREQUENCY STANDARD

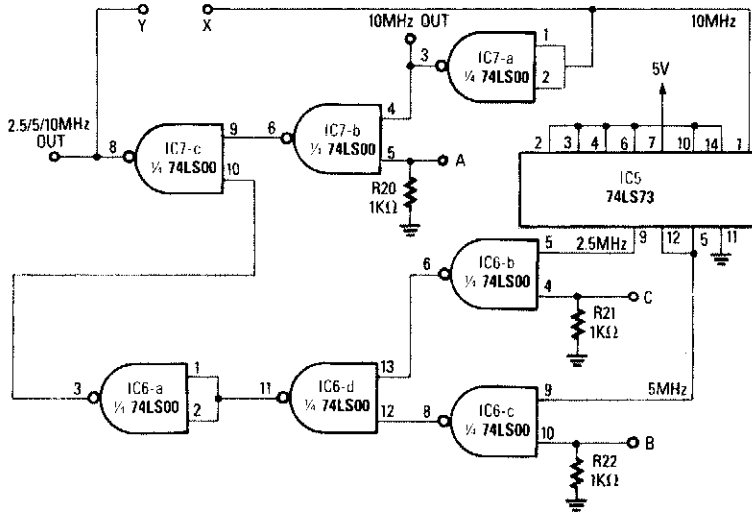

RADIO-ELECTRONICS

Fig. 50-19

ELECTROSCOPE

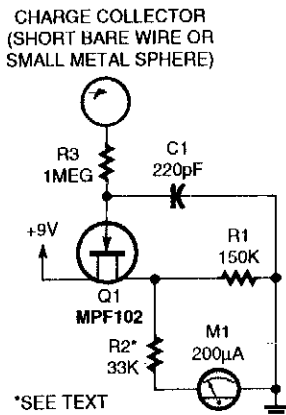

This circuit is useful for detecting electrostatic charges. In operation, C1 reduces ac noise, but lowers the sensitivity a bit. The MPF102 and R1 form a voltage divider. When the FET's gate is earth-grounded, the divider's output will be about 4.5 V giving a half-scale reading on M1, a 200- μ A meter. A positively charged object (like cotton-rubbed glass) will give a positive deflection from half-scale, and a negatively charged object (a plastic comb, for example) will give a negative meter deflection.

The whole circuit (including the 9-V battery supply) should be in a metal enclosure, and a short piece of bare wire makes a fine charge collector.

POPULAR ELECTRONICS

Fig. 50-20

OPTICAL ISOLATOR WATTMETER

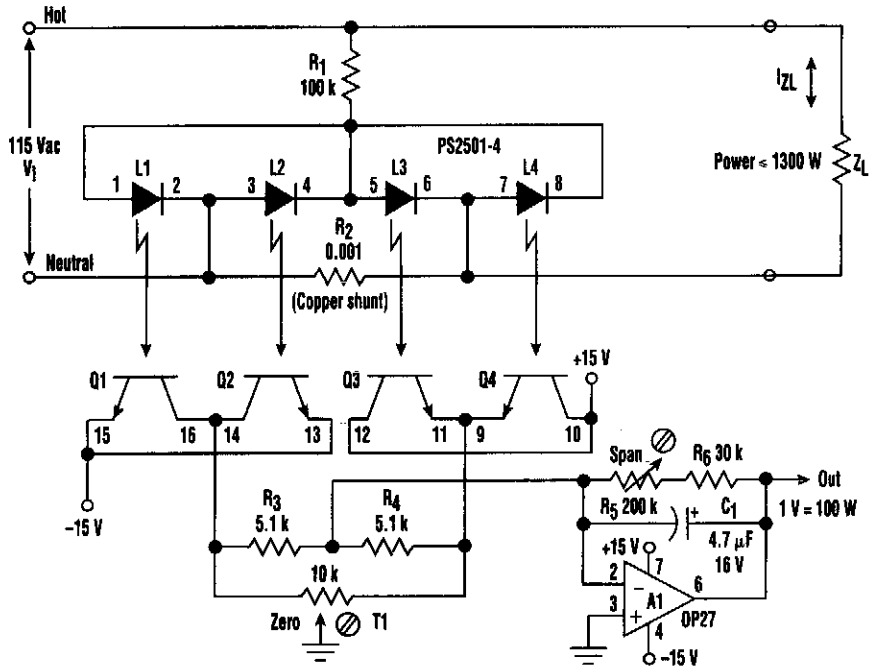

ELECTRONIC DESIGN

Fig. 50-21

The quad-channel optical isolator, consisting of LED L1 through L4 and phototransistors Q1 through Q4, is connected in a double bridge configuration. The arrangement serves to compute the four-quadrant product of ac line voltage and Z_L load current. The result is an accurate representation of the true instantaneous power delivered to the load—even if the line voltage wanders and the load is reactive and nonlinear. This wattmeter function is, of course, optically isolated from the ac line, has full-scale limit of 1300 W, and is output with scale factor of 1 V/100 W.

DIGITAL THREE-PHASE WAVE GENERATOR

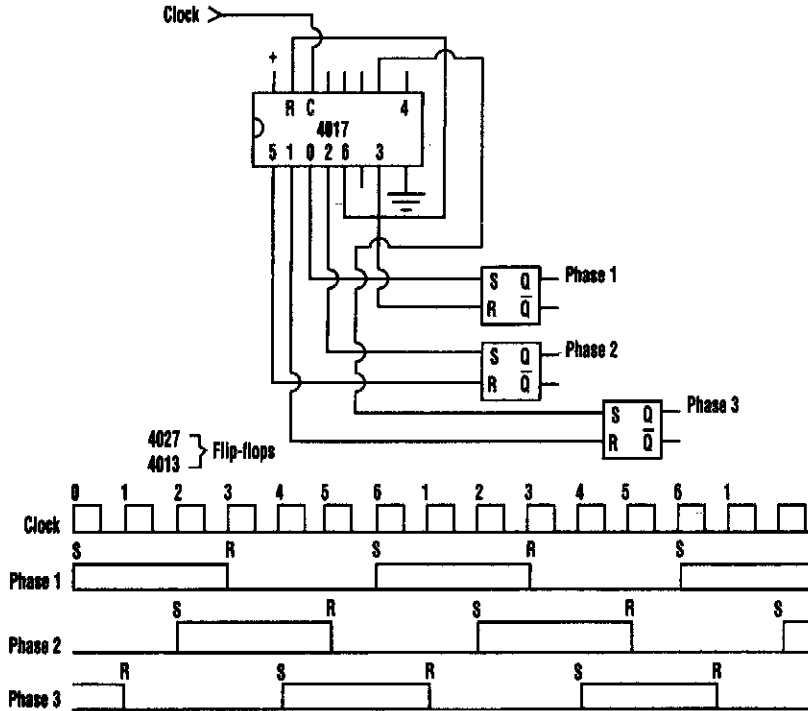

Fig. 50-22

ELECTRONIC DESIGN

With a simple digital circuit, three-phase square waves can be produced from a single-phase square-wave signal source. The timing diagram shows that the second and third phases are 120° and 240° behind the first phase, respectively.

The frequency range over which the three-phase outputs will occur is limited only by the capability of the logic used. The output frequency is 1/3 of the input frequency.

SIMPLE TEST AUDIO AMPLIFIER

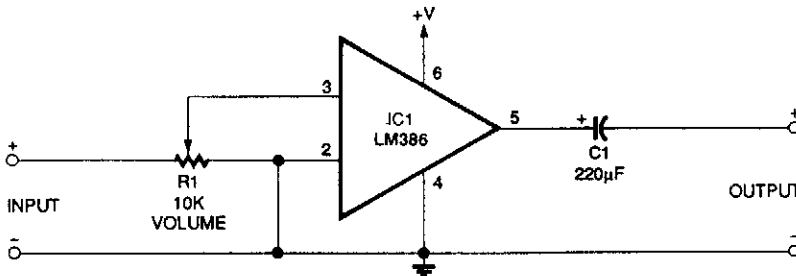
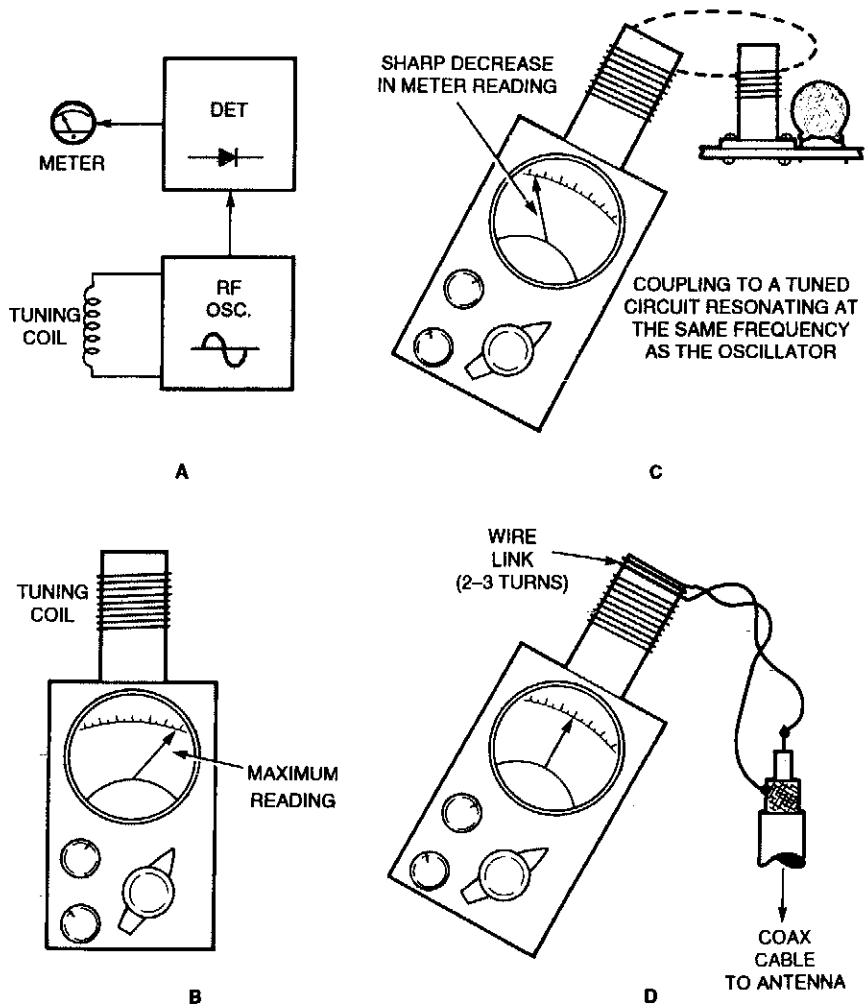

Fig. 50-23

ELECTRONICS NOW

This circuit has a gain of about 20. A suitable power supply voltage is 5 to 12 V, depending on the desired audio output power level.

GATE DIP OSCILLATOR I



POPULAR ELECTRONICS

Fig. 50-24

The typical dip meter is comprised of a tuning coil, RF oscillator, a detector, and a meter as shown in A. When the meter's tuning coil is coupled to a tuned circuit resonating at the same frequency as the GDM, the reading dips (C). The GDM's tuning coil can be coupled to the coaxial feed line of an antenna through a few (perhaps 2 to 3) turns of wire, and used to determine the antenna's resonant frequency (D).

ACCELEROMETER (G METER) CIRCUIT

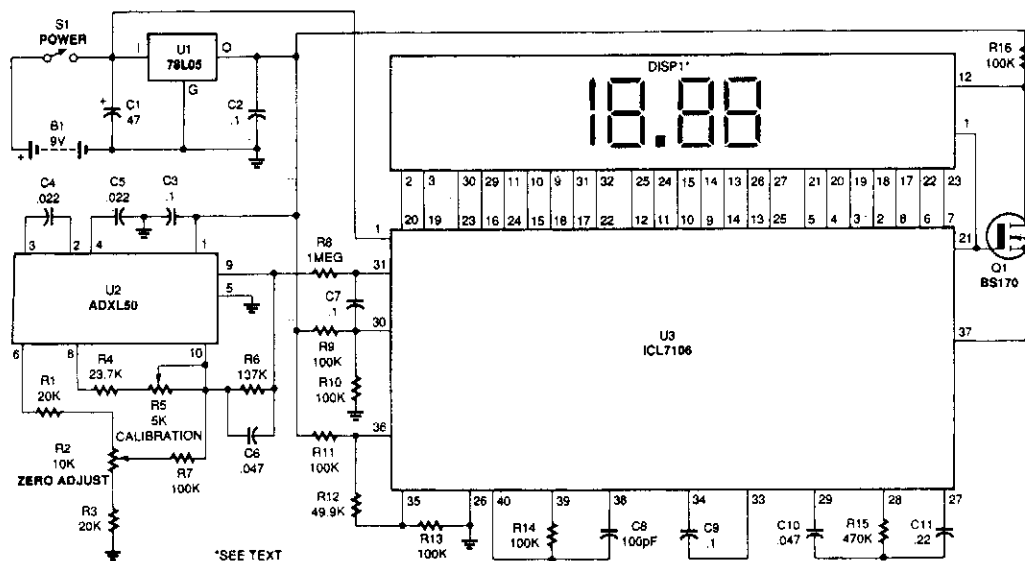

POPULAR ELECTRONICS

Fig. 50-25

As this schematic shows, the ADXL50 accelerometer, U2, interfaces with an A/D converter, U3, to drive a 3½-digit LCD module, DISP1. Because that module displays any number from -19.99 to +19.99, the circuit is designed to measure g's within that range. The heart of the circuit is U2, the ADXL50 accelerometer. The sensitivity of that chip is set to ± 20 g's in order to accommodate the full scale capability of LCD module DISP1 (19.99). Circuit gain is determined by the values of R4, R5, and R6, potentiometer R2, and R3 provides a way to manually set the zero-g voltage-output level at pin 9 of U2 to half the supply voltage—2.5 V. That output voltage will vary linearly by 0.1-V/g of acceleration.

In order to achieve good circuit performance at low g levels, the bandwidth of the amplifier is limited to about 30 Hz by C6. The digital-display section of the circuit is composed of DISP1 and U3. Included in U3 are the A/D converter, clock oscillator, storage resistors and latches, 3½-digit seven-segment decoders, and backplane generator.

The differential analog input of U3 is applied between pins 30 and 31. The positive input, pin 31, is driven by output-pin 9 of U2 through R8, a buffer resistor, and the negative input, pin 30, is biased at a fixed voltage of 2.5 V by a voltage-divider string composed of R9 and R10.

A reference voltage is required by U3. Full-scale display, 19.99, occurs when the differential, analog input voltage applied between pins 31 and 30 is equal to twice the reference voltage. The decimal point of the LCD has to be illuminated to display readings from 0.00 to 19.99. That is done by inverting the backplane square-wave drive signal appearing at pin 21 of U3, through MOSFET Q1, and applying the 180-degree out-of-phase signal to pin 12 of DISP1.

GATE DIP OSCILLATOR II

TABLE 1—COIL WINDING DATA

Band (MHz)	Turns	Wire Size/Type
3.5 6.5	45	32-enameled
6.5 11	32	26-enameled
11 19	14	20-enameled
15 24	10	20-enameled
21 36	7	insulated connection wire
32 56	4	insulated connection wire
60 .110	U-shaped*	16 enameled

*1.8-inches long

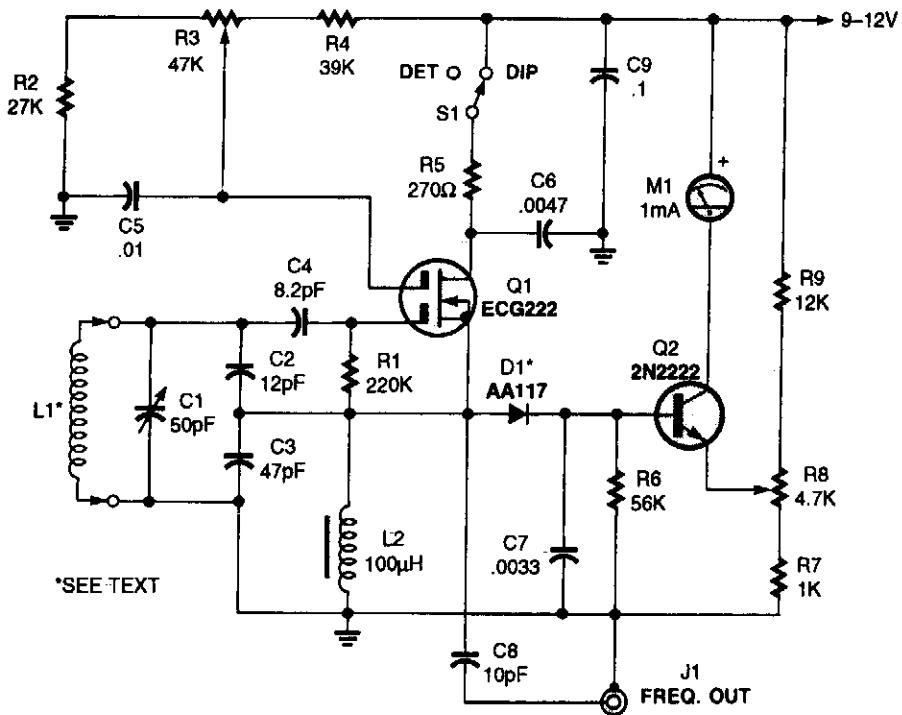

Useful for measuring the resonant frequencies of antennas, tuned circuits, and also as a tuned detector, this circuit is a modern variation of the classic vacuum tube grid dip oscillator. It coupled the G.D.O. to a tuned circuit and caused RF energy to be absorbed by the unknown tuned circuit when the G.D.O. frequency was the same as that of the tuned circuit in question. This showed as a “dip” in the meter reading.

TWO REMOTE METERS

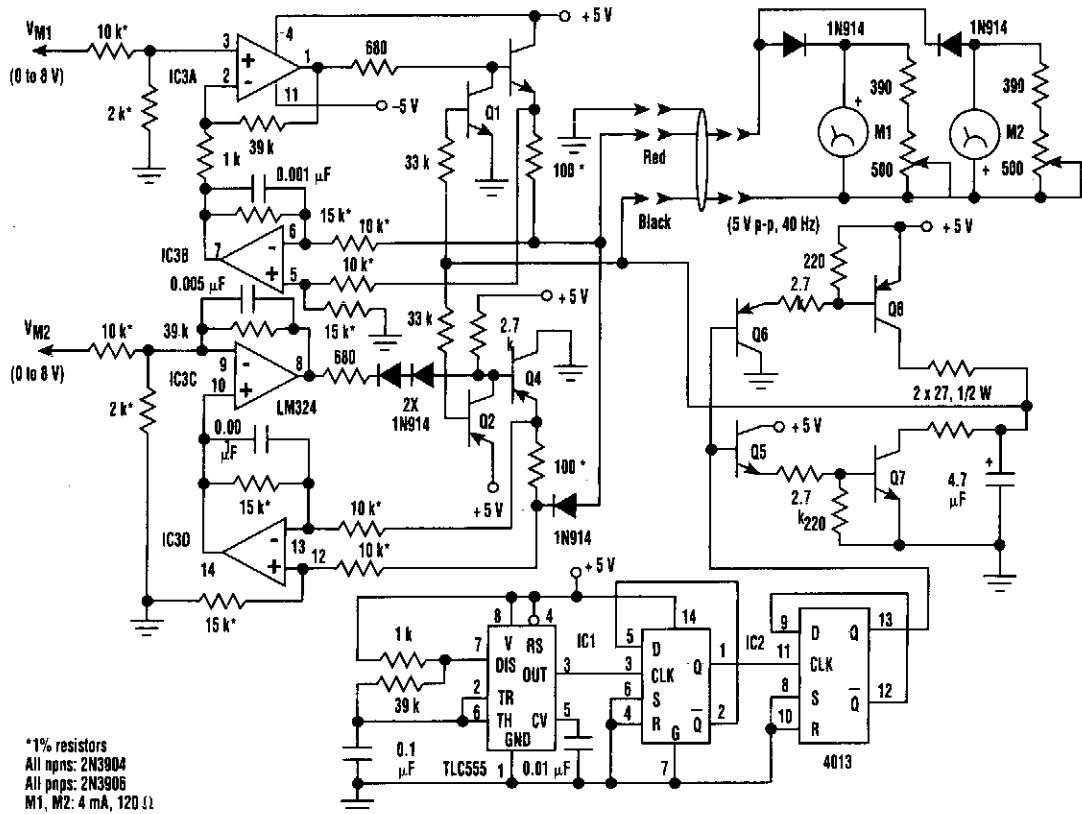

ELECTRONIC DESIGN

Fig. 50-27

Two remote meters can be driven independently using just one wire pair. This “constant current” design eliminates the effects of wire-pair resistance up to 200 Ω . Driving two remote meters independently usually requires two wire pairs (one pair for each meter).

In the circuit, IC1 and IC2 generate a 40-Hz symmetrical square wave (the frequency isn’t critical). Q5 through Q8 amplify the square wave to 5 V p-p, which is applied to the “return” (black wire) for the remote meters.

Amplifier IC3A buffers the input signal voltage V_{mi} , intended for meter M1 (0 to 8 V), and sends it through emitter-follower Q3 to a 100- Ω current-sense resistor. The other end of this resistor is tied to the “supply” (red wire) of the remote meters. IC3B amplifies the voltage across the sense resistor, which corresponds to the current sent to remote meter M1, and closes the feedback loop to IC3A.

This results in a voltage of 0 to 8 V at the M1 input, generating a current of 0 to 10 mA to M1. Transistor Q1 gates this current on and off synchronous to the 40-Hz square wave so that meter M1 actually sees a 50% 0-to-+10-mA peak (0 to 5 mA average) current.

Similarly, IC3C, IC3D, Q2, and Q4 provide a 0- to -10-mA peak current for M2. M1 and M2 are isolated by the two-reverse-connected 1N914 diodes in the remote-meter box. Variable resistors across M1 and M2 permit calibration. The extra 1N914 diode in the M2 drive circuit prevents interference between M1 and M2.

NOVEL RF POWER METER

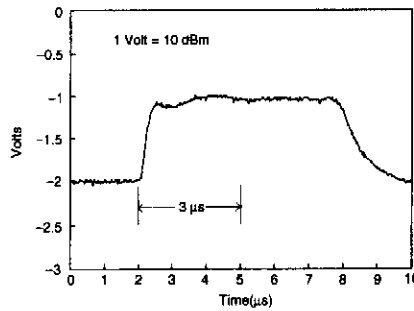
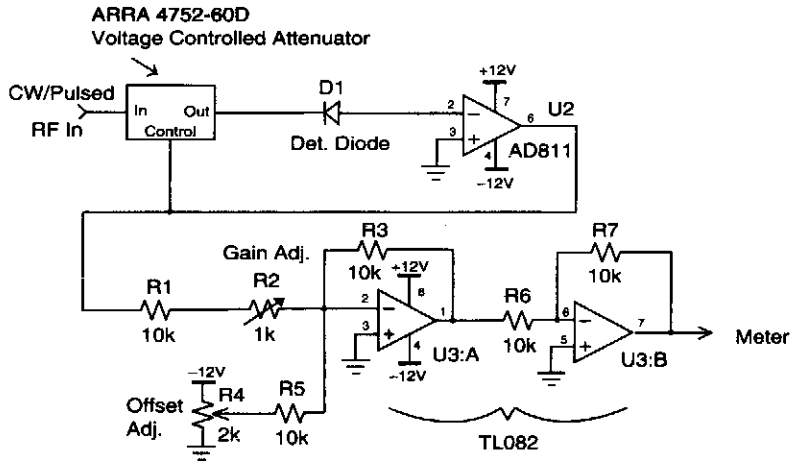

RF DESIGN

Fig. 50-28

The circuit matches the diode with a voltage-variable attenuator that has a logarithmic response. By varying the attenuation until the diode output is zero, the resulting attenuation value then corresponds to the input power level. Because the voltage-variable attenuator's output is logarithmic, diode nonlinearities become negligible.

NANOAMMETER

**Resistance Values for
DC Nano and Micro Ammeter**

I FULL SCALE	R_f [Ω]	R'_f [Ω]
100 nA	1.5M	1.5M
500 nA	300k	300k
1 μ A	300k	0
5 μ A	60k	0
10 μ A	30k	0
50 μ A	6k	0
100 μ A	3k	0

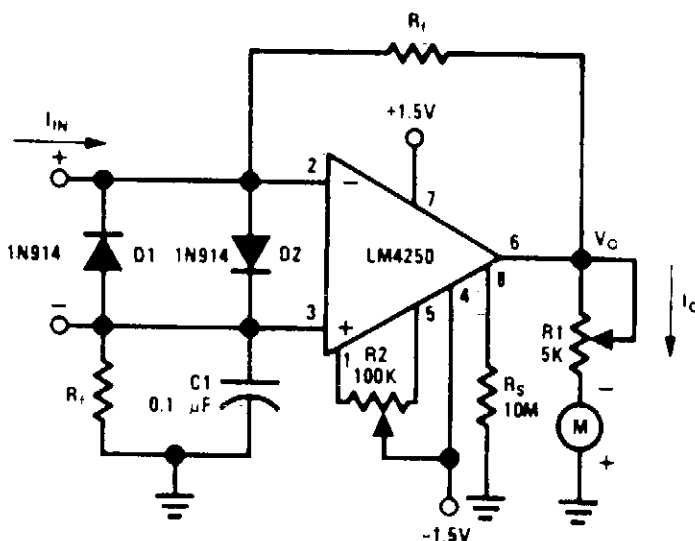
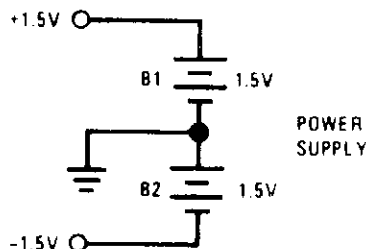

NATIONAL SEMICONDUCTOR

Fig. 50-29

Potentiometer R2 provides an electrical meter zero by forcing input offset voltage V_{os} to zero. Full-scale meter deflection is set by R1. Both R1 and R2 only need to be set once for each op amp and meter combination. For a 50- μ A 2-k Ω meter movement, R1 should be about 4 k Ω to give full-scale meter deflection in response to a 300-mV output voltage. Diodes D1 and D2 provide full input protection for overcurrents up to 75 mA.

With an R_f resistor value of 1.5 M Ω , the circuit becomes a nanoammeter with a full-scale reading capability of 100 nA. Reducing R_f to 3 k Ω in steps, as shown in the figure increases the full-scale deflection to 100 μ A, the maximum for this circuit configuration. The voltage drop across the two input terminals is equal to the output voltage (V_o) divided by the open loop gain. Assume that an open loop gain of 10,000 gives an input voltage drop of 30 μ V or less.

1.5-V LOGARITHMIC LIGHT LEVEL METER

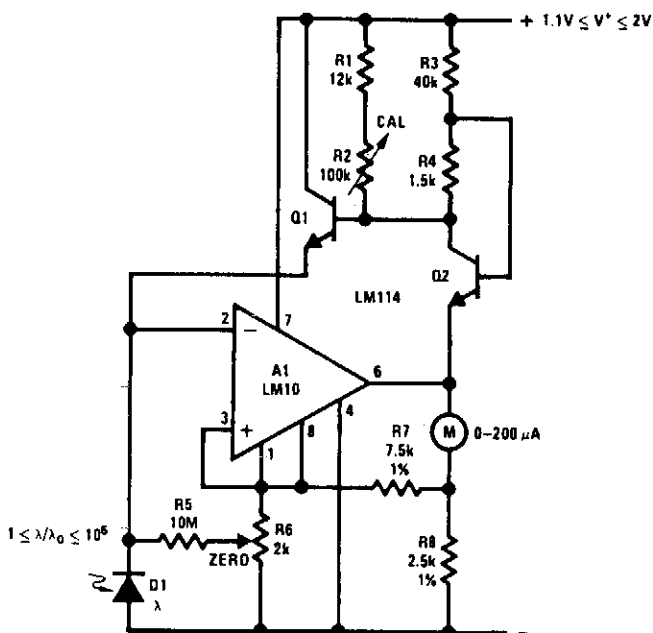

NATIONAL SEMICONDUCTOR

Fig. 50-30

A portable light-level meter with a five-decade dynamic range is shown. The circuit is calibrated at mid-range with the appropriate illumination by adjusting R2 such that the amplifier output equals the reference and the meter is at center scale. The emitter-base voltage of Q22 will vary with supply voltage; so R4 is included to minimize the effect on circuit balance. If photocurrents less than 50 nA are to be measured, it is necessary to compensate the bias current of the op amp.

The logging slope is not temperature compensated. With a five-decade response, the error at the scale extremes will be about 40% (a half stop in photography) for a $\pm 18^\circ\text{C}$ temperature change.

If temperature compensation is desired, it is best to use a center-zero meter to introduce the offset, rather than the reference compensation. It can be obtained by making the resistor in series with the meter a copper wire-wound unit.

If this design is to be used for photography, it is important to remember that silicon photodiodes are sensitive to near-infrared light, whereas ordinary film is not. Therefore, an infrared-stop filter is called for. A blue-enhanced photodiode or an appropriate correction filter would also produce best results.

ac POWER MONITOR

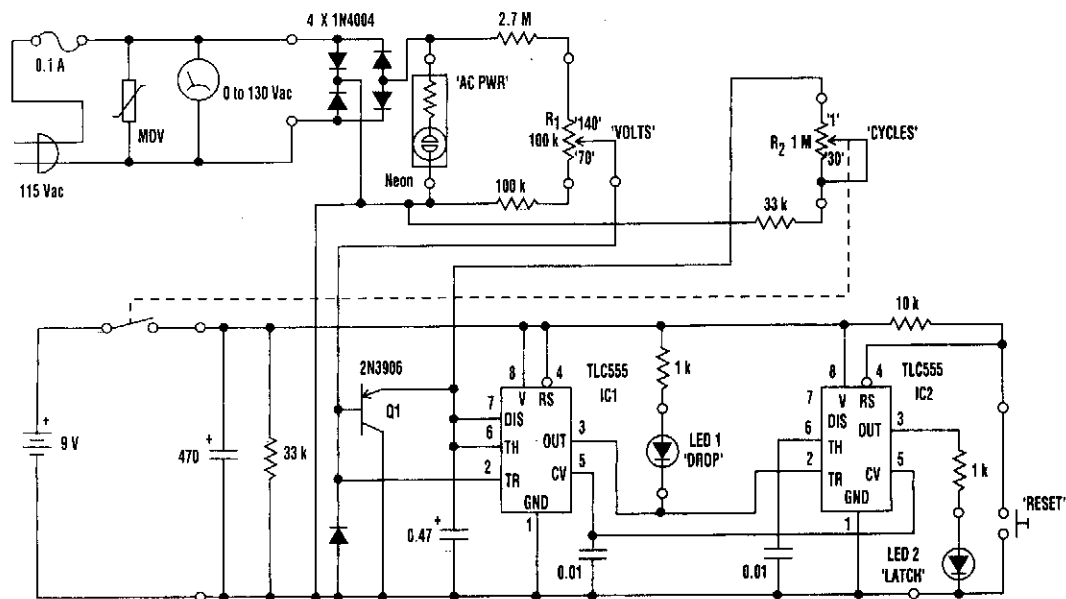

All capacitors in microfarads.
Diodes are 1N914 except where otherwise noted.

ELECTRONIC DESIGN

Fig. 50-31

The 0- to 130-V voltmeter and neon “AC PWR” lamp provide an average indication of the ac power. The fuse and metal oxide varistor (MOV) protect the monitor against overvoltage spikes.

Four 1N4004 diodes rectify the ac voltage, generating negative-going pulses twice per cycle (every 8.33 ms for 60-Hz power). Variable-resistor F1 supplies a reduced amplitude sample of these pulses to a missing pulse detector consisting of Q1, IC1, and associated circuitry. As long as the pulse amplitude exceeds the threshold value set by R1, IC1 continually triggers, keeping its output high. When the pulse amplitude drops below the threshold value, IC1 times out with a time constant set by variable resistor R2 and the 0.47- μ F capacitor. R2 is calibrated to read the number of cycles required for a dropout indication. It can be set between 1 cycle (about 17 ms) and 30 cycles (0.5 second).

When IC1 times out, its output goes low. This turns on LED1. The low output also triggers IC2, which is configured as a set-reset flip-flop. This turns on LED2. When the voltage returns to normal, IC1 again starts triggering and its output returns high, turning off LED1. LED2, however, remains on until the manual reset button is pressed.

The circuit is powered by a 9-V battery and is assembled in a plastic or grounded metal case. Notice that there's no isolation between the ac power line and the monitor circuitry. Be careful to avoid electrical shock when testing the circuitry.

100-W VARIABLE RESISTOR SIMULATOR

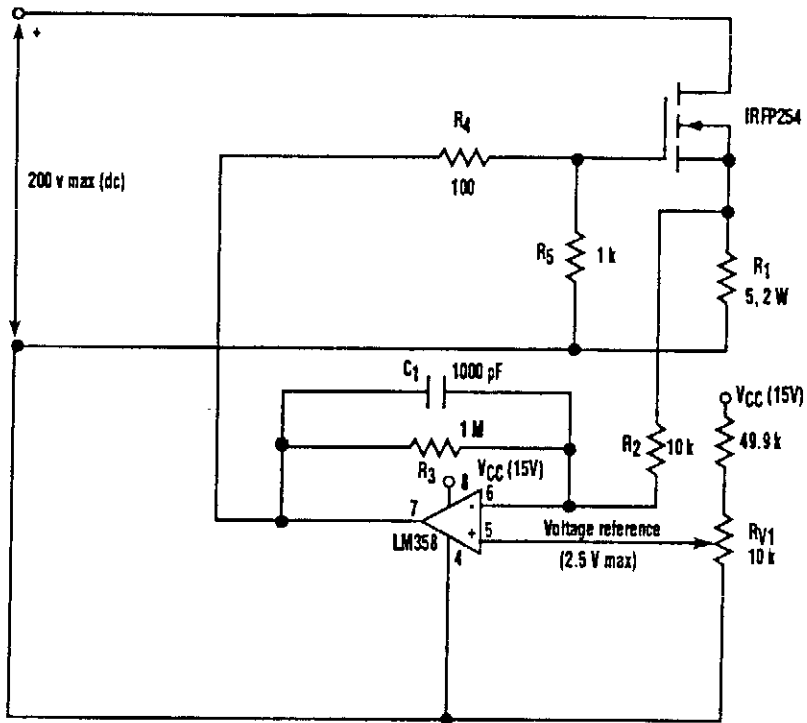

ELECTRONIC DESIGN

Fig. 50-32

Variable resistive loads with precise load steps often are required in automatic testers used to test and calibrate power supplies. The action of a high-power (100 W) variable resistor can be simulated with the circuit shown.

The voltage drop across R1, which is proportional to the FET current, is compared against a variable input voltage reference using a high-gain op amp. Error voltage developed by the amplifier drives the gate, controlling the transconductance of the FET.

Power dissipation is limited by the safe-operating-area curve of the selected FET. The FET should be mounted onto a properly sized heatsink or a heatsink-fan combination to maintain its case temperature within safe limits. The circuit is designed to dissipate a maximum power of 100 W if the FET-case temperature is maintained below 50°C. The potentiometer (RV1) can be replaced by a digital-to-analog converter so that it can adapt to the computer control for use in automatic testers.

IMD TEST CIRCUIT FOR PIN DIODES

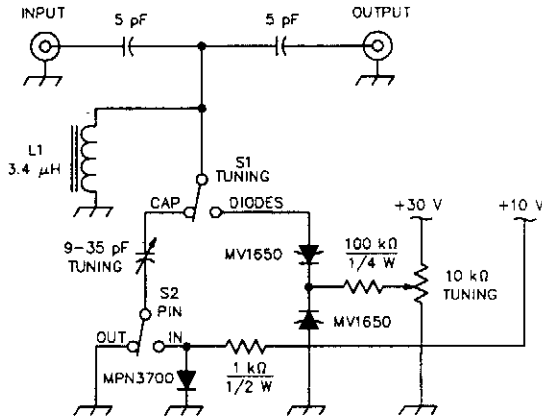

QST

Fig. 50-33

A loosely coupled tuned circuit for testing IMD production by PIN and tuning diodes in a narrow-band preselector, S1, TUNING, selects whether C1 or a pair of back-to-back MV1650 tuning diodes resonate L1. S2, PIN, adds or removes an MPN3700 PIN diode in series with C1. L1 consists of 33 turns of #28 enameled wire on a t-37-6 toroidal powdered-iron core. The MV1650, a “20-V” tuning diode, exhibits a nominal capacitance of 100 pF at a tuning voltage of 4 V.

VCO AND INPUT FREQUENCY COMPARER

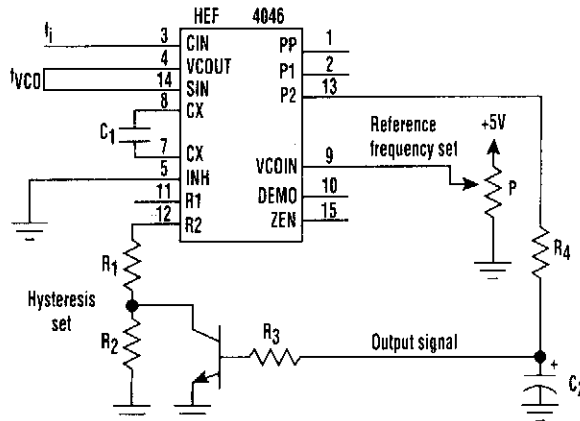

ELECTRONIC DESIGN

Fig. 50-34

Comparison of an input signal's frequency (f_i) with that of voltage-controlled oscillator (f_{VCO}) can be accomplished with just one CMOS phase-locked loop IC and a transistor (see figure). The phase and the frequency can be compared with a phase comparator, which, along with the VCO, is part of the HEF4046 PLL IC. The transistor helps introduce hysteresis, enabling the circuit to be used as a switch driver.

ECG AMPLIFIER WITH RIGHT LEG DRIVE

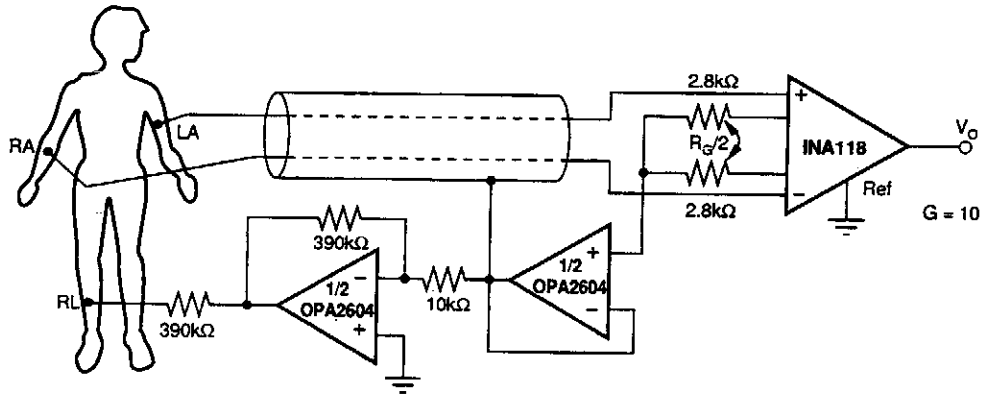

BURR-BROWN

Fig. 50-35

POWER TRANSFORMER TESTER

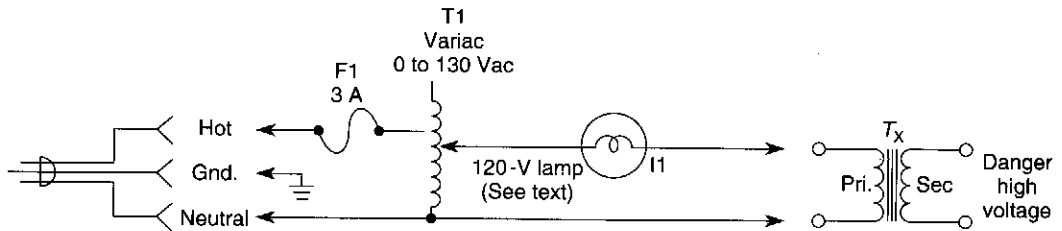

Warning: observe existing shock hazard

WILLIAM SHEETS

Fig. 50-36

Very often a power transformer is suspect and connecting a shorted transformer to an ac source can be hazardous. This test method will detect a defective or shorted transformer. The primary of the power transformer is energized through a Variac (0 to 130 Vac) and a lamp equal in wattage to about half that of the transformer under test. Connect the transformer, set Variac at zero, then energize circuit. Apply voltage to suspected transformer (Tx) as shown. The lamp should not light. If it does, Tx is shorted. Next, short the secondary of suspected Tx. This time, the lamp should light. For multiple winding transformers, repeat for each secondary winding. Beware of the shock hazard as the open windings of Tx can develop full-rated voltage.

4- TO 20-mA PROCESS CONTROLLER

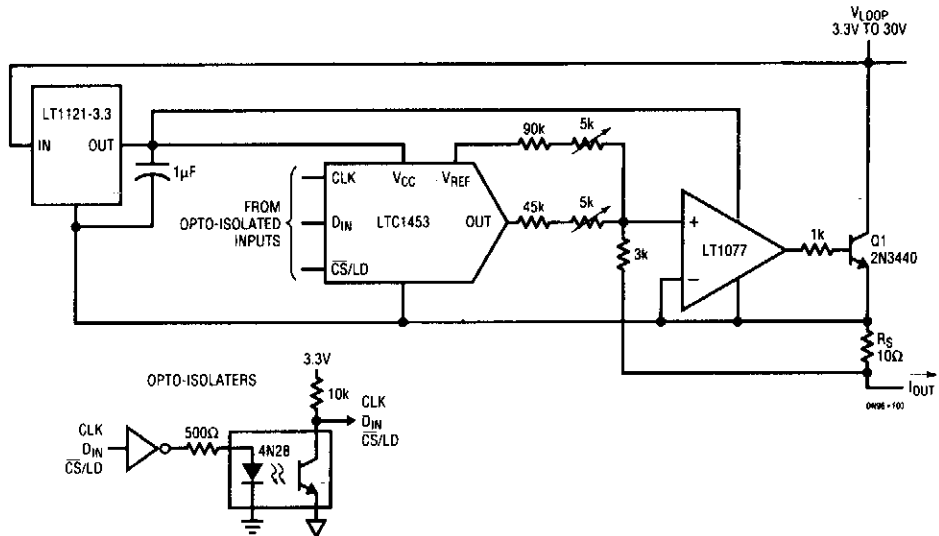

Fig. 50-37

LINEAR TECHNOLOGY

The figure shows how to use an LTC1453 to make an optoisolated digitally controlled 4- to 20-mA process controller. The controller circuitry, including the optoisolator, is powered by the loop voltage that can have a wide range of 3.3 V to 30 V. The 1.22-V reference output of the LTC1453 is used for the 4-mA offset current and V_{OUT} is used for the digitally controlled 0- to 16-mA current. R_S is a sense resistor and the LT1077 op amp modulates the transistor Q1 to provide the 4- to 20-mA current through this resistor. The control circuitry consumes well under the 4-mA budget at zero scale.

SIMPLE HIGH-CURRENT MEASURER

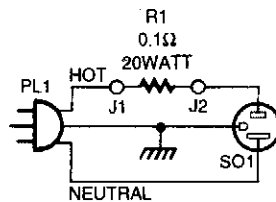
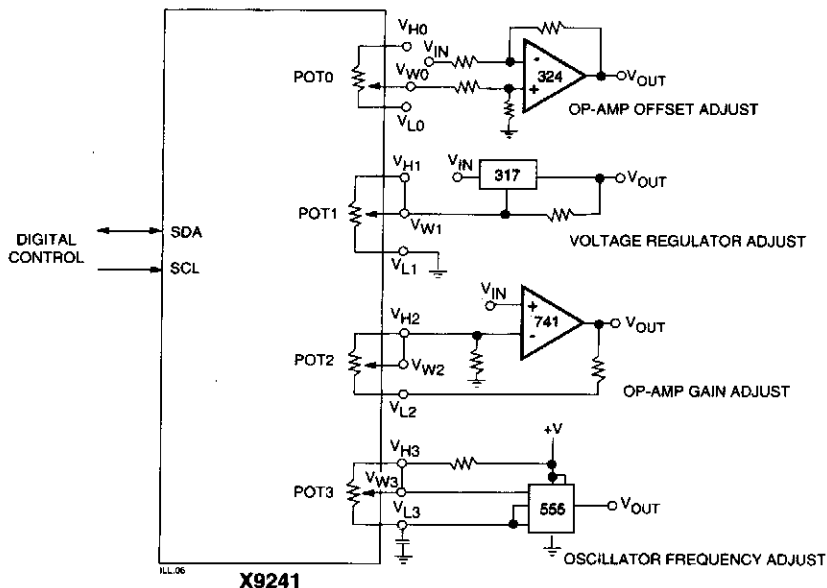

Fig. 50-38

POPULAR ELECTRONICS

Testing heavy-load devices with a ten-amp maximum meter can be accomplished with this straightforward meter add-on. If done right, it could be made from a high-current extension cord. J1 and J2 are well-insulated jacks to accept meter probe tips.

ANALOG CIRCUITRY CALIBRATOR



XICOR

Fig. 50-39

An XICOR X9241 Quad POT IC can be used to digitally adjust four analog circuits, as shown in the example schematic.

SIMPLE SIGNAL GENERATOR FOR SIGNAL TRACING

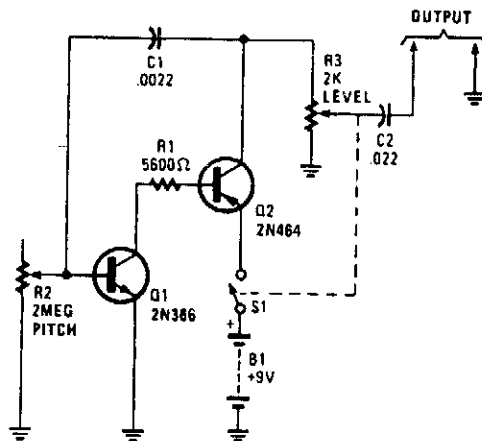

POPULAR ELECTRONICS

Fig. 50-40

A simple R-C oscillator generates a harmonic-rich waveform for signal injection.

SIMPLE HARMONIC DISTORTION ANALYZER

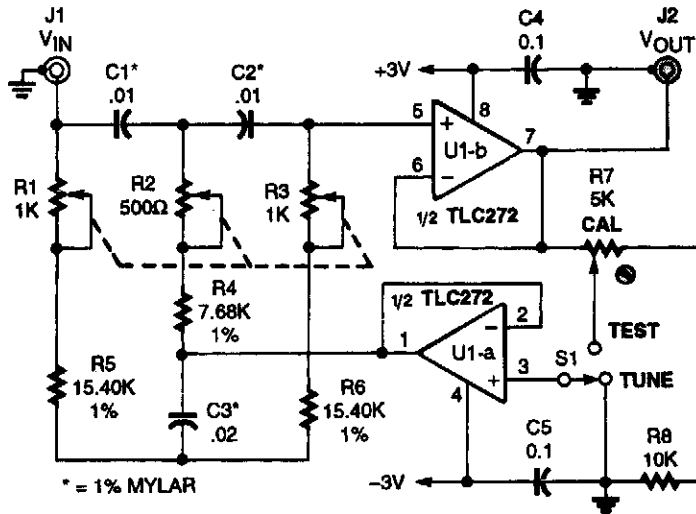

POPULAR ELECTRONICS

Fig. 50-41

This simple circuit lets you accurately measure the total harmonic distortion (THD) using your true-RMS voltmeter.

This THD circuit is somewhat different from the usual types: it can operate at the standard frequency of 1000 Hz, but it also is tunable from 970 Hz to 1030 Hz, and has an adjustable *Q* factor of 0.3 to over 50. Op-amp U1, a TLC272 CMOS unit, contains the two voltage-followers required to buffer the input to the bootstrapped twin-T notch filter. Tuning is accomplished by R1, R2, and R3, which are standard linear-taper slide pots "ganged" together by mounting them side-by-side and gluing their sliders together. The only other important construction hint is to use twisted pair at the circuit's input and output.

To calibrate the circuit, input a 1000-V RMS signal at 2000 Hz, set S1 to TEST, and adjust R7 for a reading of 0.99-V RMS on a true-RMS voltmeter at the output.

To use the circuit, set S1 to TUNE, input a 1000-Hz sine-wave signal to the amplifier under test, and set the amplifier's output to the THD adapter and tune R1/R2/R3 for the lowest output signal. Then, set S1 to TEST and read the RMS voltage. To calculate the percent THD use:

$$THD = \left(\frac{V_{out}}{V_{in}} \right) \times 100$$

SOUND SUBCARRIER GENERATOR

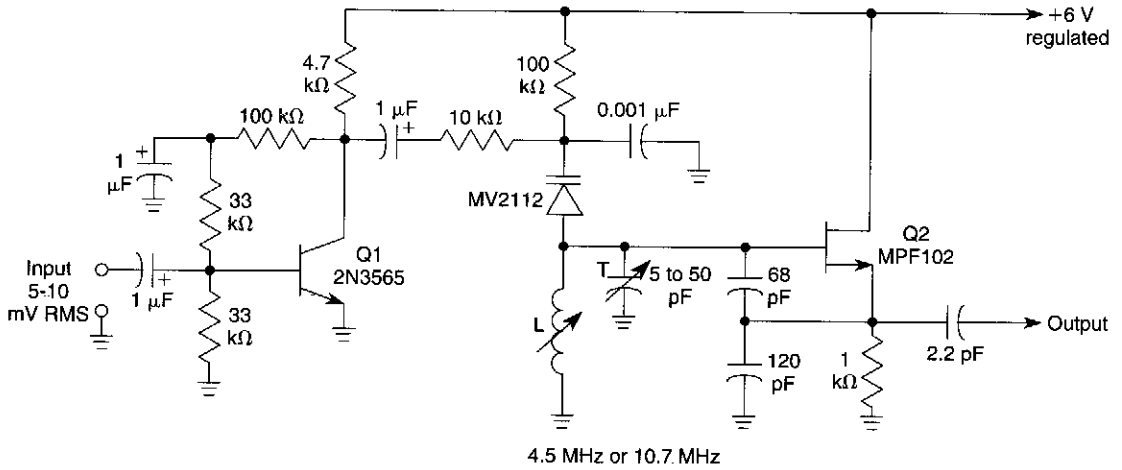

WILLIAM SHEETS

Fig. 50-42

This circuit will generate an FM sound subcarrier at 4.5 or 10.7 MHz for FM and TV IF testing and alignment. Q1 is an audio amplifier and Q2 is a VCO modulated by an MV2112 varactor. Deviation up to 1% of frequency can be obtained. L is chosen to resonate with the circuit capacitance to either 4.5 or 10.7 MHz. The values will be around 2 to 10 μH , depending on the frequency.

INDUCTANCE AND CAPACITANCE DETERMINER WITH SWR BRIDGE

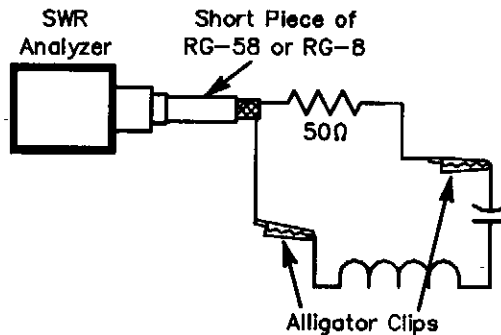

QST

Fig. 50-43

At resonance, the SWR will be 1:1 with a 50- Ω resistance, as reactance is zero. If either L or C is known:

$$|X_C| = |X_L| = \frac{1}{2\pi f C} = 2\pi f L$$

$$L_{\text{unknown}} = \frac{1}{(2\pi f)^2 C} \quad C_{\text{unknown}} = \frac{1}{(2\pi f)^2 L}$$

MOTORCYCLE TUNE-UP AID

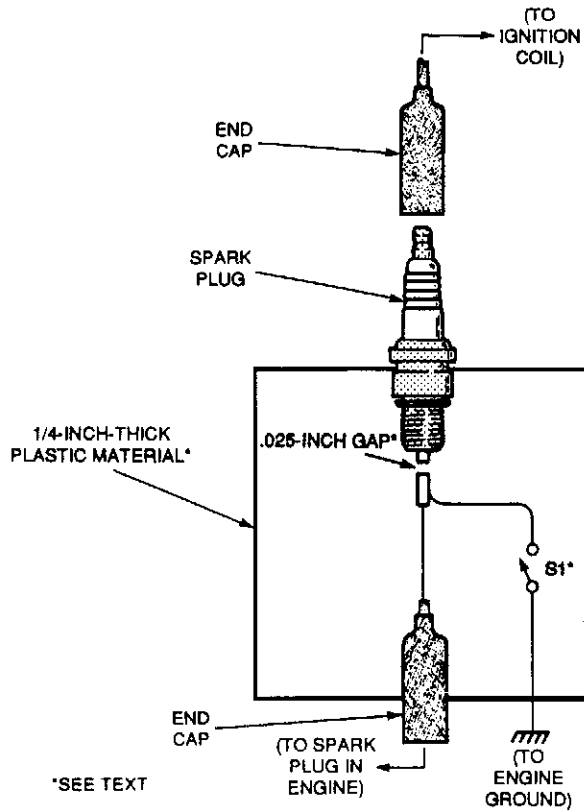

POPULAR ELECTRONICS

Fig. 50-44

Performing a tune-up on a newer bike is made a lot easier with this helpful circuit. Because of the high voltages present, make sure that S1 has an insulated handle and that the fixture is grounded. With the ignition turned off, remove one of the spark plug wires and connect it to the spark plug on the fixture. Slip the fixture's end cap over the spark plug on the cycle and you're ready to go. Open S1 and start the engine. Then, close S1; the cylinder with the fixture should not fire and a spark should be seen at the fixed gap. Be sure that the fixture is connected to the engine ground before closing S1.

50-MHz FREQUENCY COUNTER

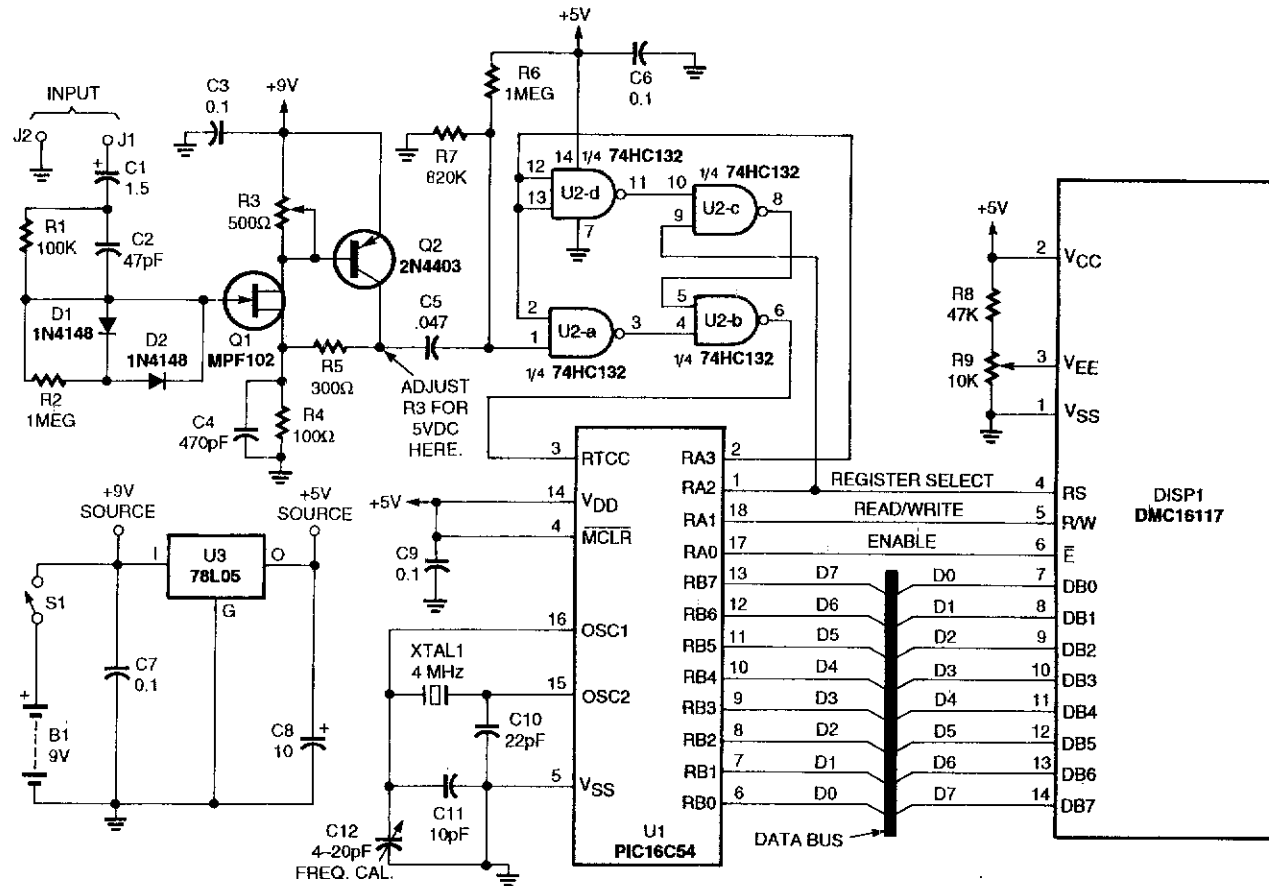

POPULAR ELECTRONICS

Fig. 50-45

This inexpensive frequency counter uses a microcontroller as the counter. The microcontroller feeds an LCD display module that accepts standard ASCII code. The frequency is displayed as Hz, kHz, or MHz and the counter is autoranging.

10-MHz FREQUENCY STANDARD

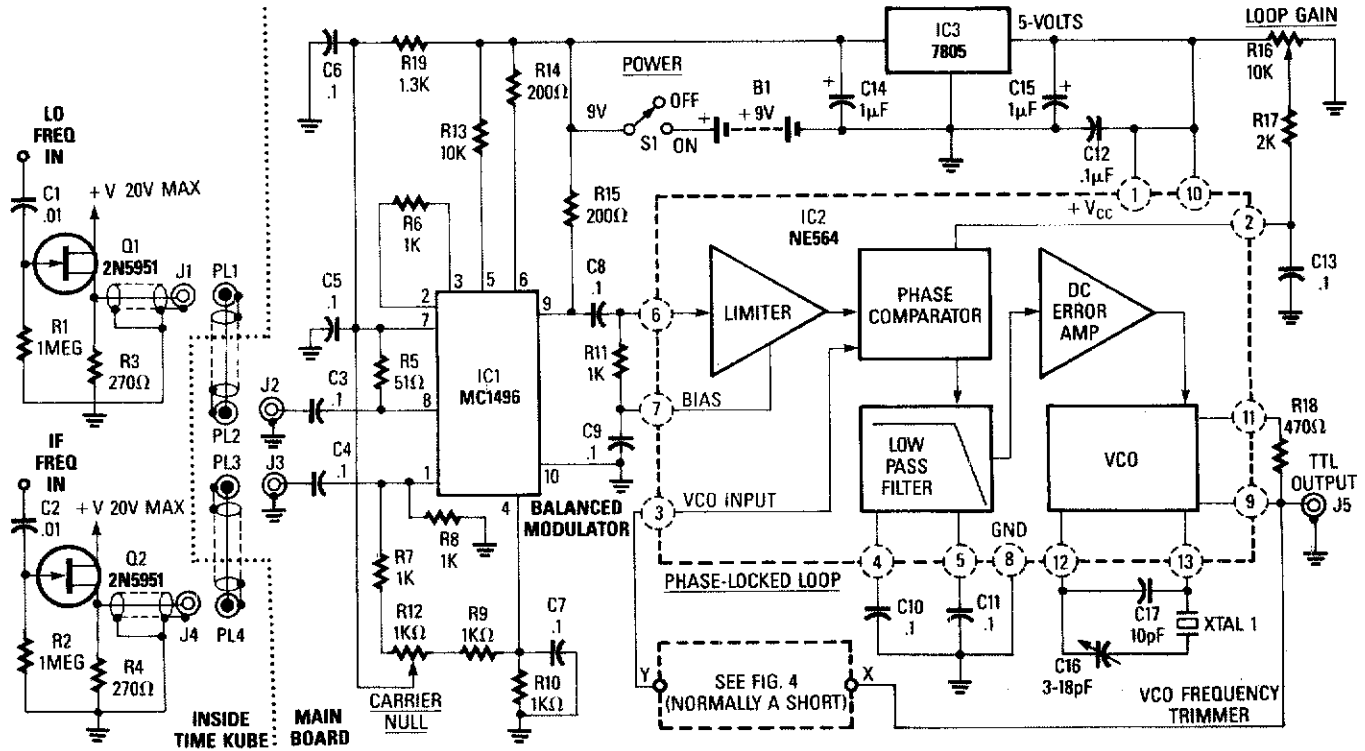

A Radio Shack 10-MHz receiver is used as a basis for this circuit. The L.O. and IF frequencies are added. When the receiver is tuned to 10 MHz (WWV), the sum of the L.O. and IF are used to phase lock a VCO to the 10-MHz signal. By using a divider in the loop, 2.5 or 5 MHz can be used as well.

PROGRAMMABLE CAPACITOR CIRCUIT

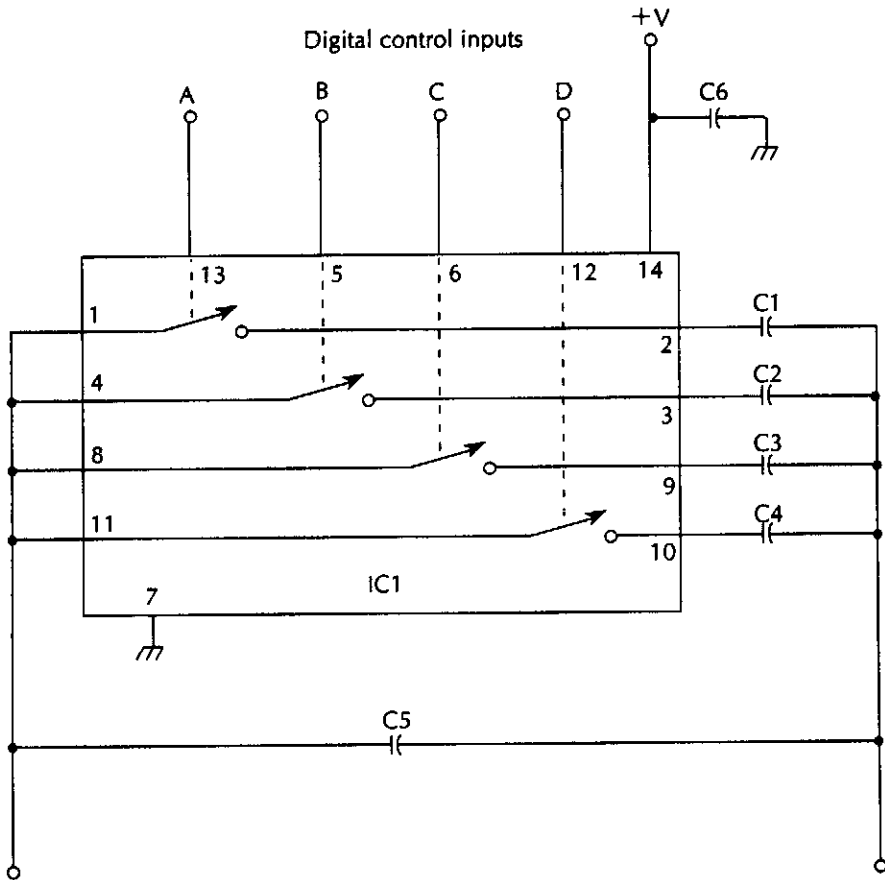

McGRAW-HILL

Fig. 50-47

- IC1 CD4066 quad bilateral switch
- C1 10- μ F, 25-V capacitor
- C2 22- μ F, 25-V capacitor
- C3 47- μ F, 25-V capacitor
- C4 100- μ F, 25-V capacitor
- C5 1- μ F, 25-V capacitor
- C6 0.1- μ F, 25-V capacitor

The programmable capacitor can be very useful in circuits where you need to switch capacitance values. Remember that the "ON" resistance of IC1 appears in series with the capacitors and must be taken into account in some applications as it is not negligible.

PROGRAMMABLE RESISTOR CIRCUIT

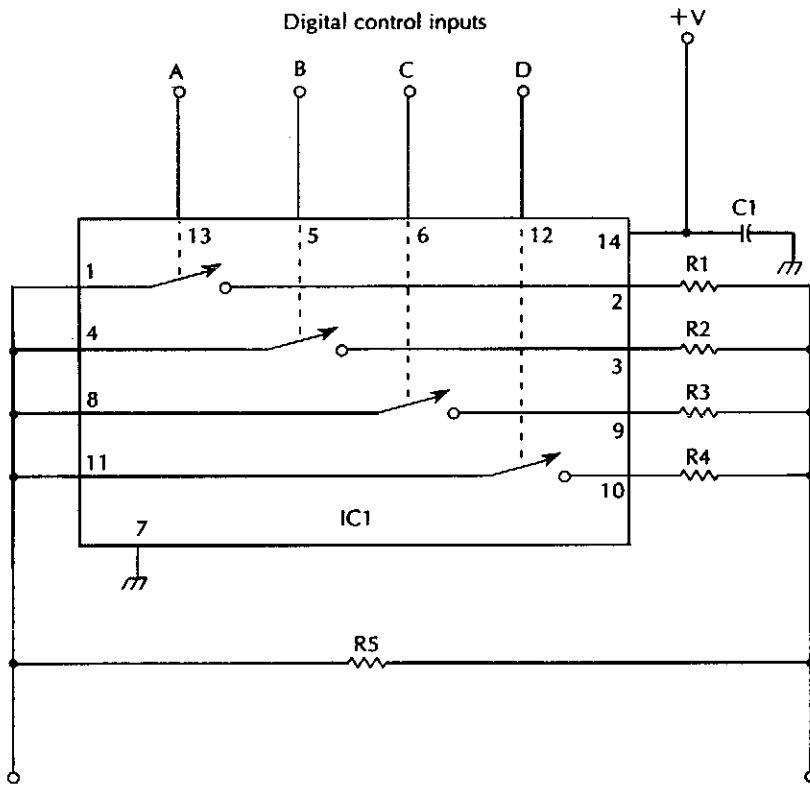

McGRAW-HILL

Fig. 50-48

- IC1 CD4066 quad bilateral switch
- C1 0.1- μ F capacitor
- R1 10-k Ω , 1/4-W 5% resistor
- R2 4.7-k Ω , 1/4-W 5% resistor
- R3 2.2-k Ω , 1/4-W 5% resistor
- R4 1-k Ω , 1/4-W 5% resistor
- R5 1-M Ω , 1/4-W 5% resistor

A programmable resistor can replace a potentiometer or fixed resistor. Remember that the "ON" resistance of IC1 might have to be taken into account in some applications.

51

Metronome Circuits

The sources of the following circuits are contained in the Sources section, which begins on page 707. The figure number in the box of each circuit correlates to the entry in the Sources section.

Audible Metronome
Visual Metronome

AUDIBLE METRONOME

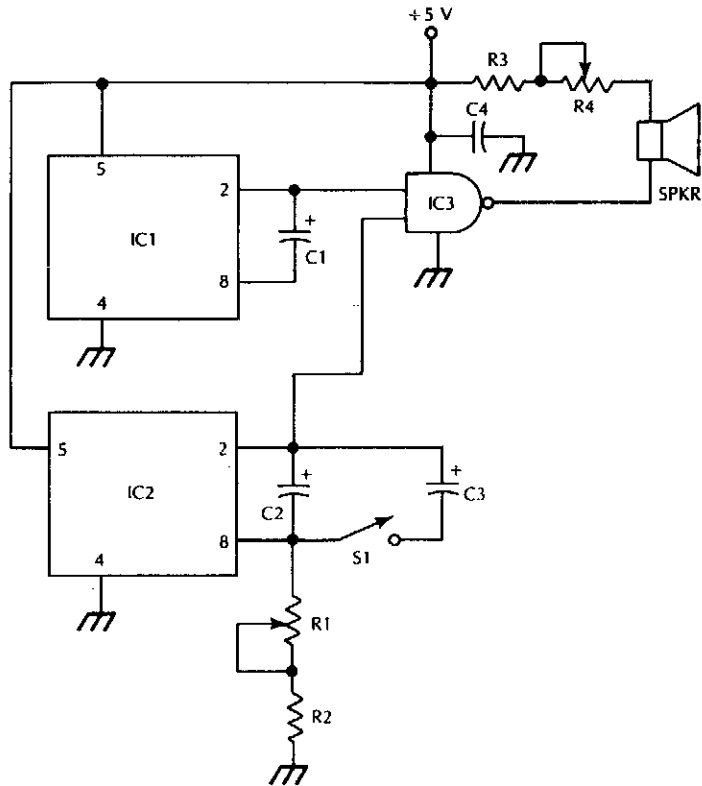

IC1, IC2	LM3909 LED flasher/oscillator	C3	47 μ F 10 V electrolytic capacitor
IC3	7400 quad NAND gate	C4	0.01 μ F capacitor
SPKR	small loudspeaker	R1	50 k Ω potentiometer
S1	SPST switch	R2	3.3 k Ω 1/4 W 5% resistor
C1	1 μ F 10 V electrolytic capacitor	R3	47 k Ω 1/4 W 5% resistor
C2	100 μ F 10 V electrolytic capacitor	R4	500 Ω potentiometer

McGRAW-HILL

Fig. 51-1

IC1 generates an audible frequency while a variable very low frequency is generated by IC2. R1 sets the metronome rate. The two signals are combined in IC3.

VISUAL METRONOME

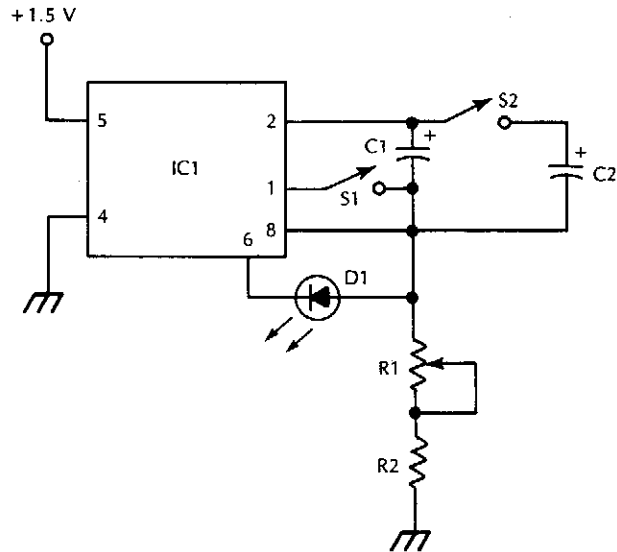

IC1	LM3909 LED flasher/oscillator	C2	47 μ F 6 V electrolytic capacitor
D1	LED	R1	50 k Ω potentiometer
S1, S2	SPST switch	R2	3.3 k Ω 1/4 W 5% resistor
C1	100 μ F 6 V electrolytic capacitor		

McGRAW-HILL

Fig. 51-2

52

Miscellaneous Treasures

The sources of the following circuits are contained in the Sources section, which begins on page 707. The figure number in the box of each circuit correlates to the entry in the Sources section.

MOSFET Drive Current Booster	Underwater Microphone
Simple Event Counter	Pulse Echo Driver
Frequency Doubler	Simple Pseudorandom Voltage Source
Atmosphere Noise Monitor	TV Horizontal Deflection Circuit
Tachometer Derived from Brushless Shaft Angle	Muting Circuit
Resolver	Simple Remote Gain Control
Vocal Stripper	Loop Oscillator Eliminator
Vocal Stripper Power Supply	1-A Voltage Follower
Single-Chip Message System	Electronic Fish Lure
Television Vertical Deflection Circuit	Heartbeat Transducer
Tone Burst Generator	Contact Debouncer
Audio Volume Limiter	Positive Feedback Cable Terminator
Simple Intercom for Noisy Environments	$\times 10$ Frequency Multiplier
Ditherizer	Jacob's Ladder
Triac Lamp Dimmer Circuit	Master-Slave Device Error Checker
500-kcps 8-Channel Data Acquisition Circuit	Ground Loop Preventer
Hydrophone	Dual Tone Generator for Audio Servicing
Your Name in Lights	Diodeless Peak-Hold Circuit

MOSFET DRIVE CURRENT BOOSTER

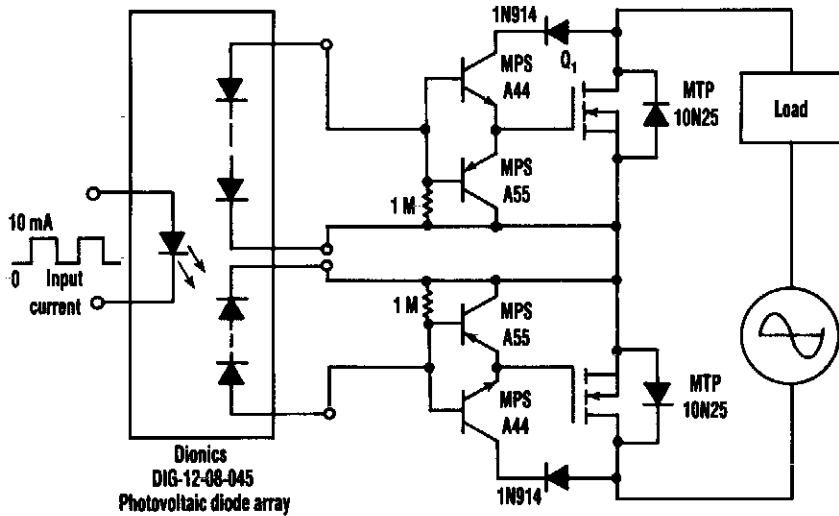

ELECTRONIC DESIGN

Fig. 52-1

A clean and inexpensive way to eliminate the floating-gate supply is to use the voltage available at the MOSFET's drain to drive its gate. Tying the collector of Q1 (a high-voltage, small-signal, 400-V NPN) to the MOSFET's drain supplies sufficient gate-drive voltage when it's needed most—when the MOSFET's drain-to-source voltage is high. Two such circuits used back-to-back form an ac relay.

Using the emitter follower attached to the drain increases gate-drive current and decreases the MOSFET's turn-on time by a factor equal to the high-voltage NPN's beta. The resulting drain-to-source voltage fall times depend on the MOSFET's size and its required gate charge. The circuit that's used gives a fall time of 200 μ s for an MTP10N2f5 10-A, 250-V MOSFET. With such fall times cutting switching losses, pulse-width modulation at frequencies under 100 Hz is possible.

During tune-on, V_{DS} falls rapidly until it reaches the sum of the 1N914 diode's 0.7-V drop, the collector-emitter saturation voltage of Q1, and the gate-to-source voltage required to support the load current. At that point, the diode array completes the MOSFET's turn-on, unaided by the buffer. This slows the fall of V_{DS} considerably when it reaches about 5 to 7 V. In high-voltage, low-frequency systems, tailing of V_{DS} is tolerable because the tail's voltage magnitude constitutes a small fraction of the switching voltage. The 1N914 makes it possible for V_{GS} to exceed V_{DS} as the MOSFET completes turn-on.

SIMPLE EVENT COUNTER

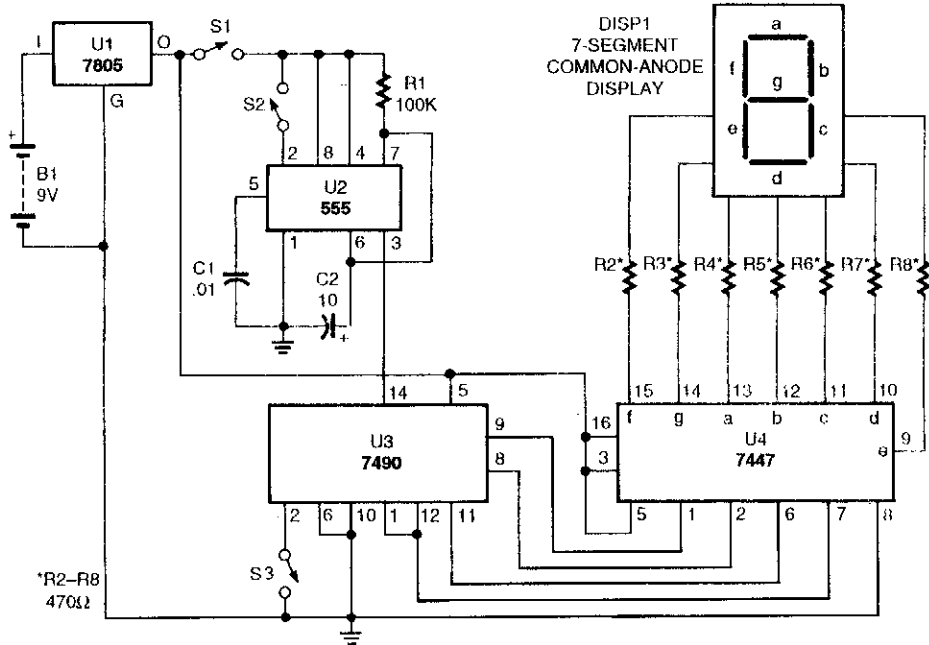

POPULAR ELECTRONICS

Fig. 52-2

S1 is a power switch. U2 drives counter U3 by producing a pulse when S2 is depressed. U4 and DISP1 read the count of counter IC U3. S3 is a reset to zero switch. The counter is a basic one-digit circuit useful as a holding block or by itself.

FREQUENCY DOUBLER

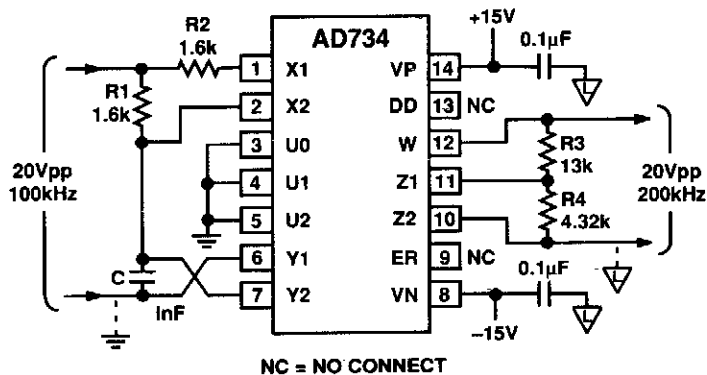

NC = NO CONNECT

ANALOG DEVICES

Fig. 52-3

An Analog Devices AD734 four-quadrant analog multiplier is used as a frequency doubler.

ATMOSPHERE NOISE MONITOR

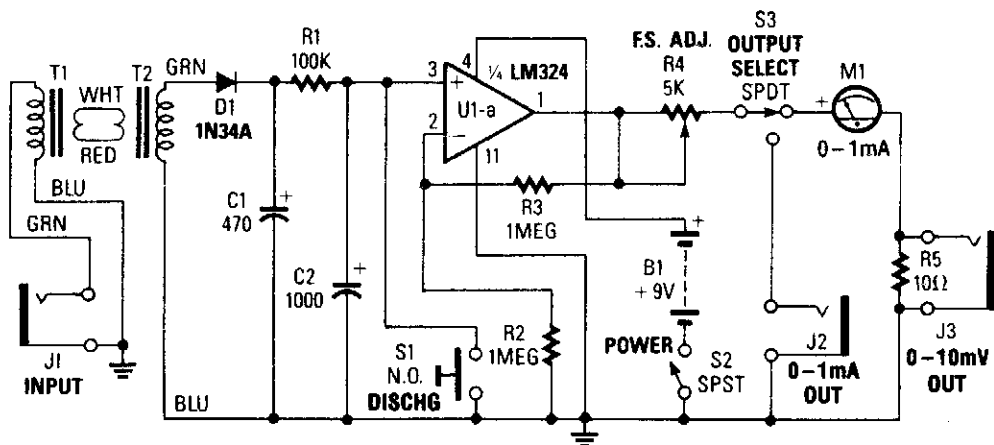

POPULAR ELECTRONICS

Fig. 52-4

Tune an unmodified transistor radio to an unused frequency near 540 kHz that's free of broadcast-station interference; the receiver is used to pick up sferics. The received signal is fed from the receiver's earphone jack through a patch cord to the input jack (J1) of the circuit. The back-to-back audio transformers, T1 and T2, provide a suitable impedance match and signal level when the unit is used with various receivers.

Diode D1 rectifies the audio input from the receiver to pulsating dc, which is filtered by C1, R1, and C2 to provide a time constant of several minutes. That dampens out fluctuations in most cases, unless lightning flashes are very infrequent.

The voltage appearing at the output of the filter is a function of signal strength transferred by C1. Switch S1 is included to provide a convenient way to discharge the capacitors, if adjustments are required during a monitoring session.

Integrated circuit U1 (one section of an LM324 quad pro op amp) is used as a high input-resistance voltmeter. Resistors R2 and R3 determine amplifier gain, and potentiometer R4 is used to adjust full-scale meter deflection for a suitable voltage level at the input. A value of 1.5 V has been satisfactory for use with several receivers tried, but they can be changed.

If the monitor is to be used only as a meter, the milliammeter can be connected directly between R4 and chassis ground, omitting R5, S3, J2, and J3. The latter components provide suitable output for use with a chart recorder having a full-scale range of either 10 mV or 1 mA. The circuit, when powered from a 9-V battery, draws about 1 mA.

TACHOMETER DERIVED FROM BRUSHLESS SHAFT ANGLE RESOLVER

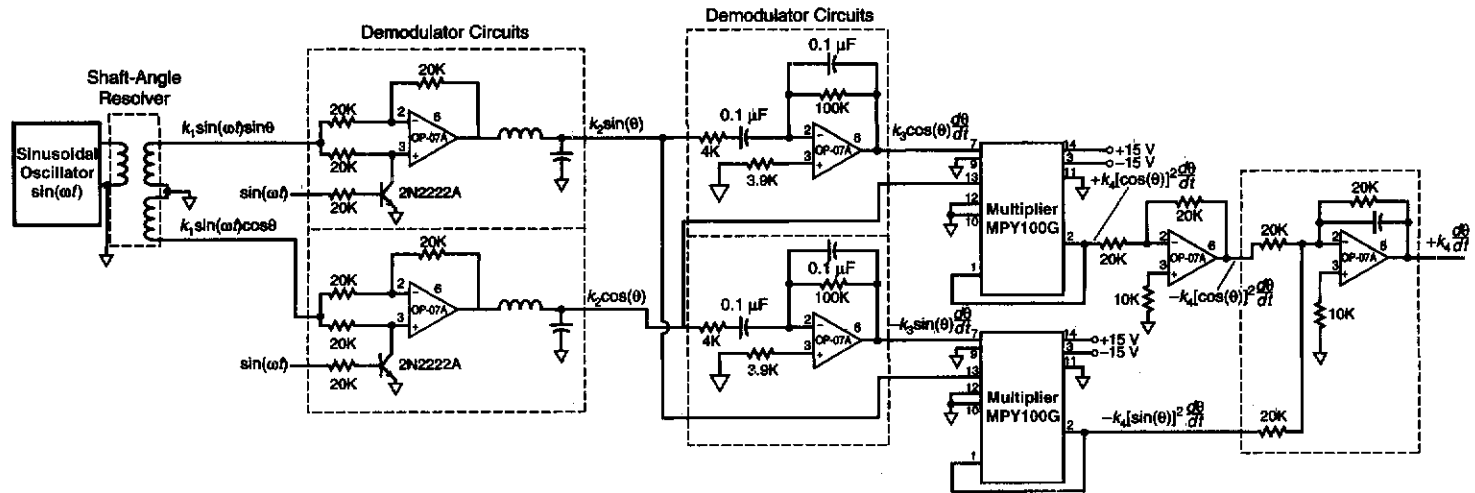

NASA TECH BRIEFS

Fig. 52-5

The tachometer circuit operates in conjunction with a brushless shaft-angle resolver. By performing a sequence of straightforward mathematical operations on the resolver signals and utilizing a simple trigonometric identity, it generates a voltage proportional to the rate of rotation of the shaft.

The figure illustrates an analog tachometer circuit that processes the input and output signals of a two-phase, brushless, transformer-type shaft-angle resolver into a signal with instantaneous amplitude proportional to the instantaneous rate of rotation of the shaft. The processing in this circuit effects a straightforward combination of mathematical operations leading to a final operation based on the well-known trigonometric identity $[\sin(x)]^2 + [\cos(x)]^2 = 1$ for any value of x .

The resolver is excited with a periodic waveform; a sinusoid is indicated in the figure, but a square, triangular, or other periodic waveform could be used instead. Thus, the two outputs of the resolver are $k_1 \sin(\omega t) \sin(\theta)$ and $k_1 \sin(\omega t) \cos(\theta)$, where k_1 is a constant proportional to the amplitude of excitation, ωt is $2\pi x$ the frequency of excitation, t is time, and θ is the instantaneous shaft angle.

The two outputs of the resolver are then processed, along with a replica of the sinusoidal excitation, by demodulators. These signals are then differentiated with respect to time in two differentiator circuits. Notice that $d\theta/dt$ is the rate of change of the shaft angle and is the quantity that one seeks to measure.

Next, a multiplier circuit forms a product of the demodulator and differentiator outputs proportional to $\sin(\theta)$, and the product of the demodulator and differentiator outputs proportional to $\cos(\theta)$. The output of the cosine multiplier is fed to a unit-gain inverting amplifier.

VOCAL STRIPPER

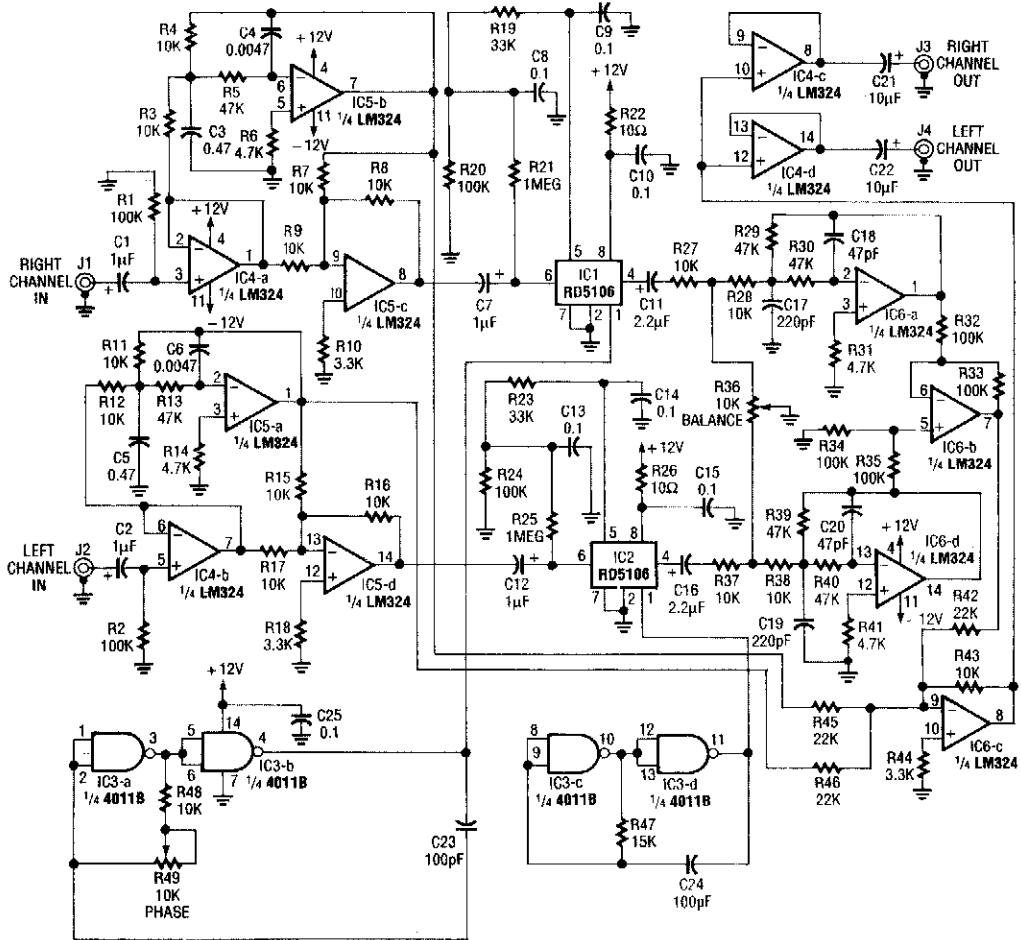

RADIO-ELECTRONICS

Fig. 52-6

The schematic of the lead vocal filter is shown in the figure. The left and right channel signals are coupled through C1 and C2 to buffer amps IC4-a and IC4-b. From the buffer amps, the left and right channel signals pass through active crossovers IC5-a and IC5-b, sending all low frequencies to a final mixer IC6-c, and all middle and high frequencies to analog delay lines IC1 and IC2, RD5106 256-sample bucket-brigades. Integrated circuit IC2 delays the left-channel signal by 2.4 ms, set by the fixed-frequency clock generated by $\frac{1}{2}$ IC3, R47, and C24. The right channel signal is delayed by IC1 with a variable-frequency clock generated by $\frac{1}{2}$ IC3, R48, R49, and C23. Potentiometer R49 is used for phase adjustment.

The output of each delay line from IC1 and IC2 passes through low-pass filters IC6-a and -d, and their associated parts, to filter out high-frequency sample-steps produced by IC1 and IC2. Balance control R36 is adjusted for equal amplitude of the left and right channels. IC6-b is a difference amplifier that cancels all lead vocals that are common to both channels. The resulting signal from IC6-b is remixed with low frequencies by IC6-c and is then sent to the output via buffers IC4-c and IC4-d.

VOCAL STRIPPER POWER SUPPLY

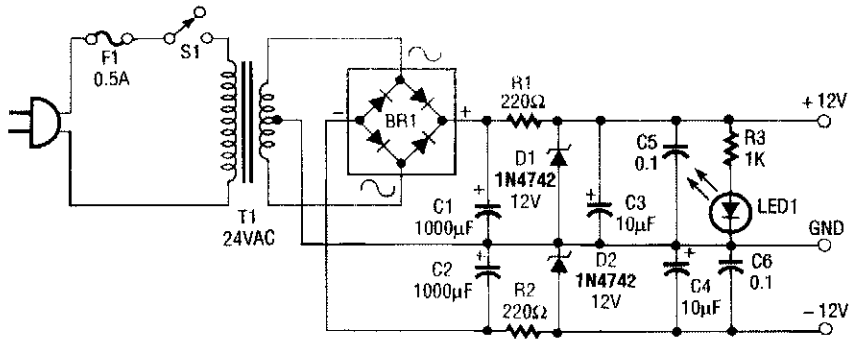

RADIO-ELECTRONICS

Fig. 52-7

The power supply schematic for the lead vocal filter circuit.

SINGLE-CHIP MESSAGE SYSTEM

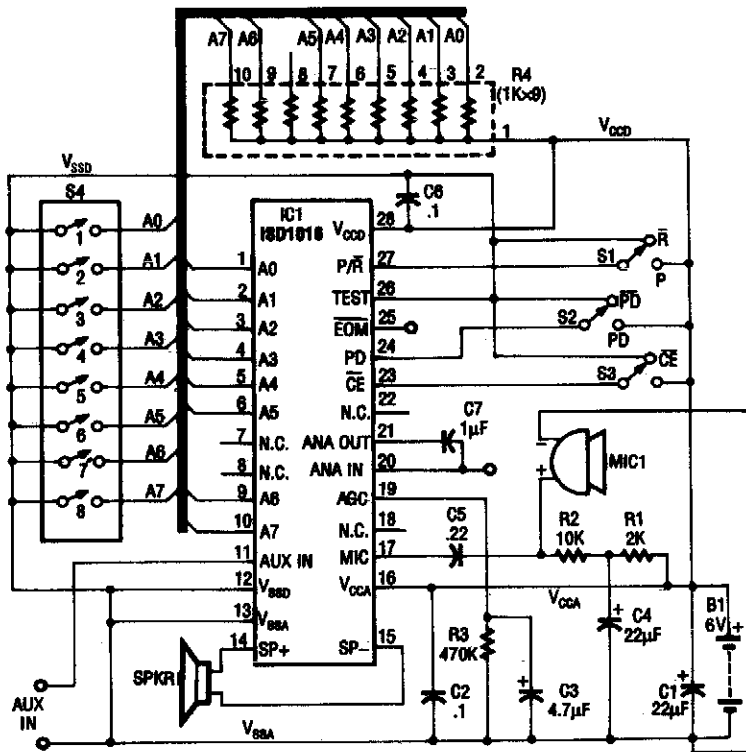

ELECTRONICS EXPERIMENTERS HANDBOOK

Fig. 52-8

The ISD1016 is a complete analog audio record/playback system on a chip. The analog signal is sampled and the samples stored in an EEPROM as analog levels. Upon playback, the analog data is read out and amplified. Up to 16 seconds of data (audio) can be stored.

TELEVISION VERTICAL DEFLECTION CIRCUIT

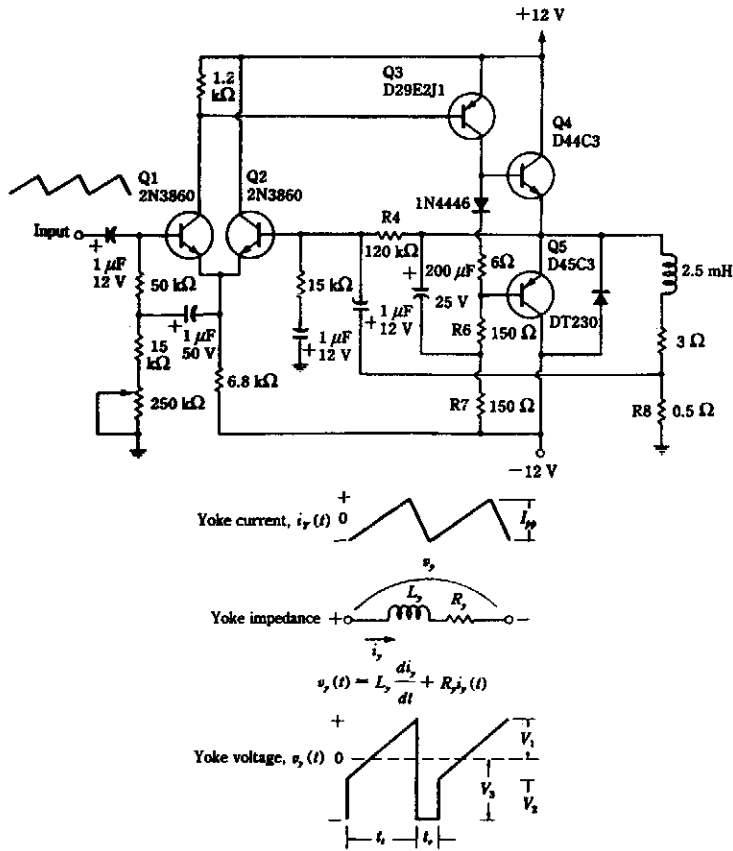

McGRAW-HILL

Fig. 52-9

Two transistors are used to drive the yoke ($2.5 \text{ mH} + 0.3 \Omega$) in this deflection circuit. R8 samples the yoke current and provides feedback to Q2, resulting in a very linear current ramp through the yoke.

TONE BURST GENERATOR

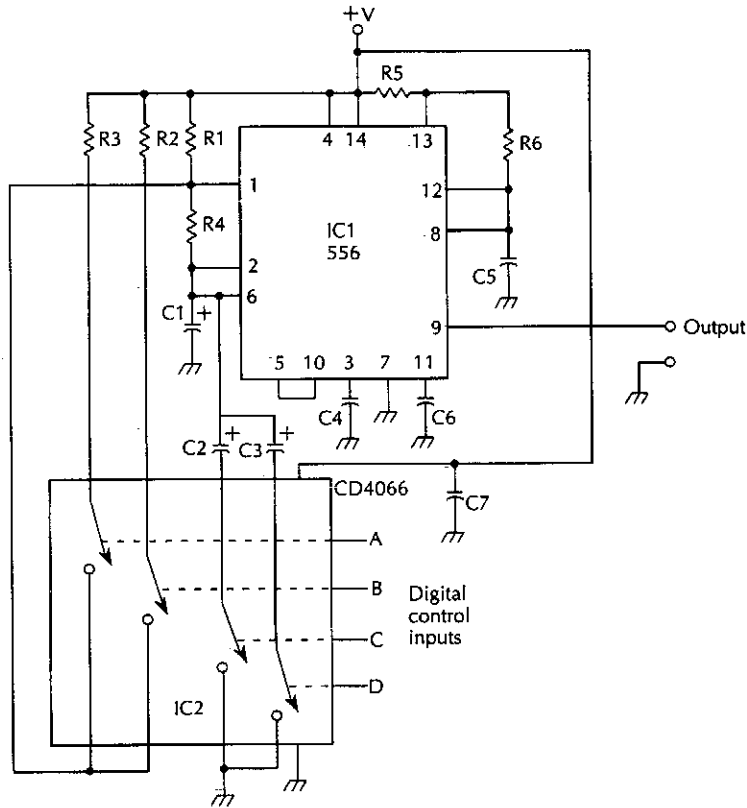

McGRAW-HILL

Fig. 52-10

The burst length is digitally controlled by inputs A, B, C, D. This input selects the necessary values of R and C . The circuit shown in the figure generates a burst of tone followed by a silent period, then another tone burst is sounded and so forth. The timing of the tone bursts is digitally controlled via the CD4066 (IC2). A parts list for this circuit is given in the table.

IC1	555 dual timer (or two 555 timers)	C5	0.047- μ F capacitor
IC2	CD4066 quad bilateral switch	R1	100-k Ω , $\frac{1}{4}$ -W 5% resistor
C1	1- μ F, 25-V electrolytic capacitor	R2, R4	220-k Ω , $\frac{1}{4}$ -W 5% resistor
C2	4.7- μ F, 25-V electrolytic capacitor	R3	680-k Ω , $\frac{1}{4}$ -W 5% resistor
C3	10- μ F, 25-V electrolytic capacitor	R5	12-k Ω , $\frac{1}{4}$ -W 5% resistor
C4, C6	0.01- μ F capacitor	R6	4.7-k Ω , $\frac{1}{4}$ -W 5% resistor

AUDIO VOLUME LIMITER

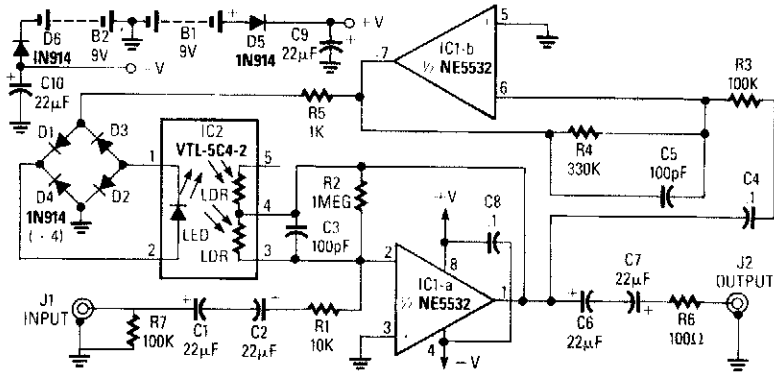

RADIO-ELECTRONICS

Fig. 52-11

In this circuit, amplifier IC1-a provides signal amplification of -40 to +40 dB depending on the value of the LDR. The LDR (light dependent resistor) is driven by rectified audio from voltage follower IC1b and bridge rectifier D1 through D4.

SIMPLE INTERCOM FOR NOISY ENVIRONMENTS

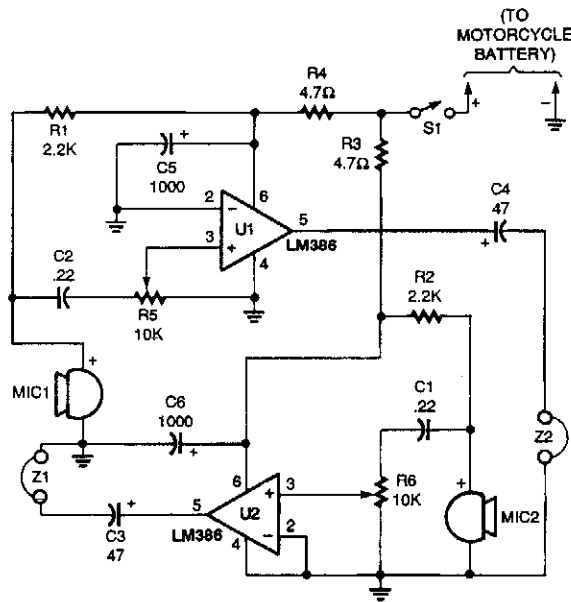

POPULAR ELECTRONICS

Fig. 52-12

This intercom was originally designed for motorcycle to passenger communications. A simple "passenger-to-pilot" intercom circuit is shown. Two LM386 ICs are connected in a low-gain amplifier circuit with the headphone output of one paired to the microphone input of the other. The microphones are electret elements and the earphones can be of the in-ear type or of the small stereo/mono type that will fit inside a helmet. Both amplifiers in the circuit operate at a minimum gain of 20 dB.

DITHERIZER

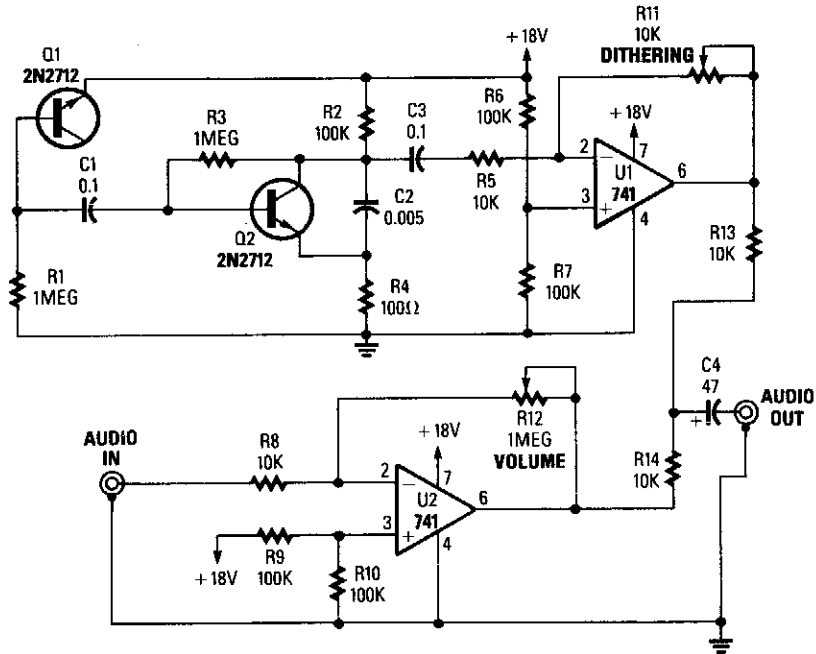

POPULAR ELECTRONICS

Fig. 52-13

In digital audio, a noise signal of amplitude less than one significant bit is often added to the audio to reduce the quantizing effect and improve the audio quality by trading digital “noise” for analog noise, which does not have the harsh sound. This circuit consists of a noise generator to add a low level of noise to an analog signal to be digitized, or an analog signal from a digital source.

TRIAC LAMP DIMMER CIRCUIT

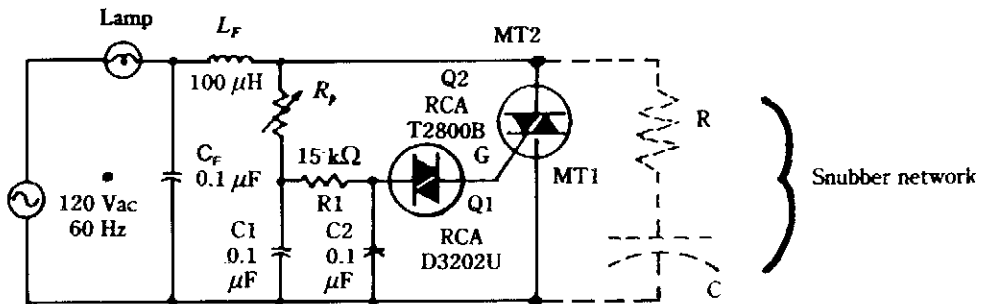

For 220-V, 50/60-Hz Operation,
replace T2800B with T2800D.

McGRAW-HILL

Fig. 52-14

The brightness of a lamp or lamps can be varied with this circuit. The snubber circuit values are typically 0.1 μF and 100- Ω . R_s is typically 25 to 100 k Ω .

500-kps 8-CHANNEL DATA ACQUISITION CIRCUIT

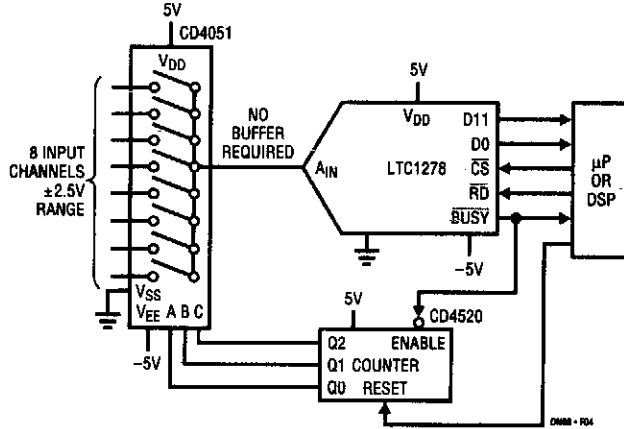

LINEAR TECHNOLOGY

Fig. 52-15

The high input impedance of the LTC1278 allows multiplexing without a buffer amplifier. Both single channel and multiplexed high-speed data acquisition systems benefit from the LTC1278/LTC1279's dynamic conversion performance. The 1.6- μ s and 1.4- μ s conversion and 200-ns and 180-ns S/H acquisition times enable the LTC1278/LTC1279 to convert a 500 kps and 600 kps, respectively. The figure shows a 500-kps 8-channel data acquisition system. The LTC1278's high input impedance eliminates the need for a buffer amplifier between the multiplexer's output and the ADC's input.

HYDROPHONE

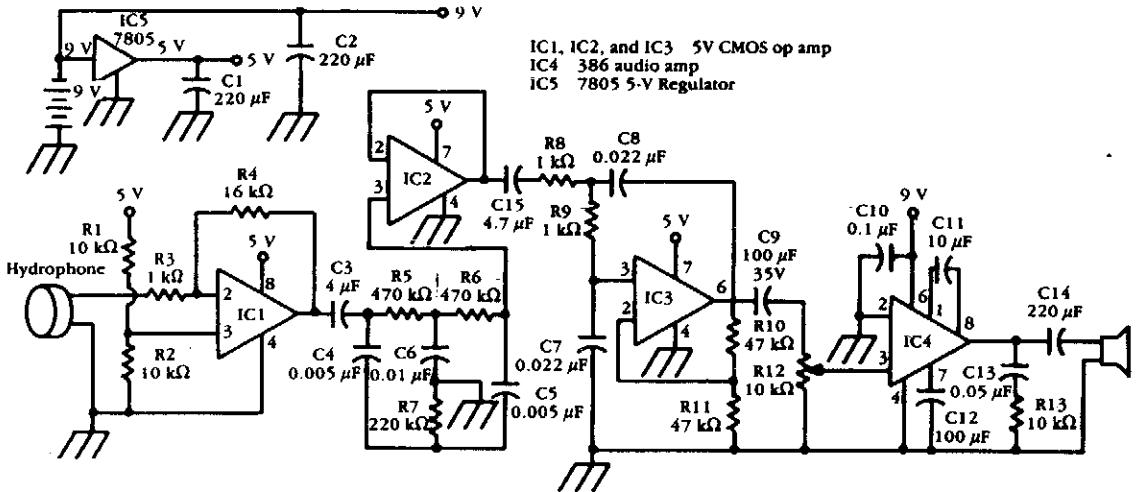

McGRAW-HILL

Fig. 52-16

A commercially available hydrophone transducer is used in this system. The transducer is connected via a cable to the amplifier, which remains out of the water. The hydrophone should be suitably mounted for intended application.

YOUR NAME IN LIGHTS

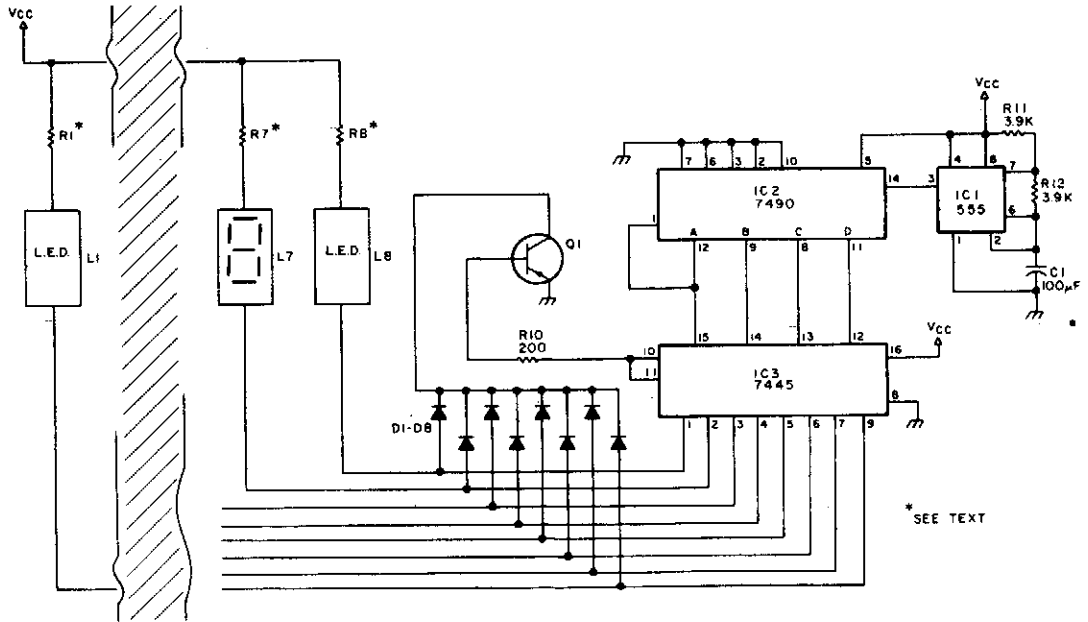

73 AMATEUR RADIO TODAY

Fig. 52-17

This circuit will enable you to put a name or callsign in lights using seven-segment LEDs. The display will spell the desired name out sequentially. Select the correct type of LED. Solder the correct leads together to form the letters you want. After mounting the appropriate current-limiting resistor, the 7445 can only sink 80 mA, so a PNP transistor is needed to handle the current required to light the letters. The heart of the circuit is a 555 oscillator into a 7490 decade counter, which is decoded by a 7445 open-collector driver chip.

UNDERWATER MICROPHONE

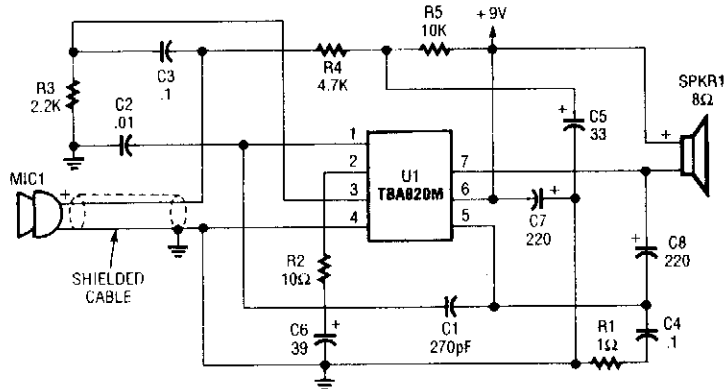

ELECTRONIC HOBBYISTS HANDBOOK

Fig. 52-18

This circuit uses a TBA820 audio IC to amplify underwater sounds. The microphone must be waterproofed. This project was originally used in a home aquarium to monitor fish sounds.

PULSE ECHO DRIVER

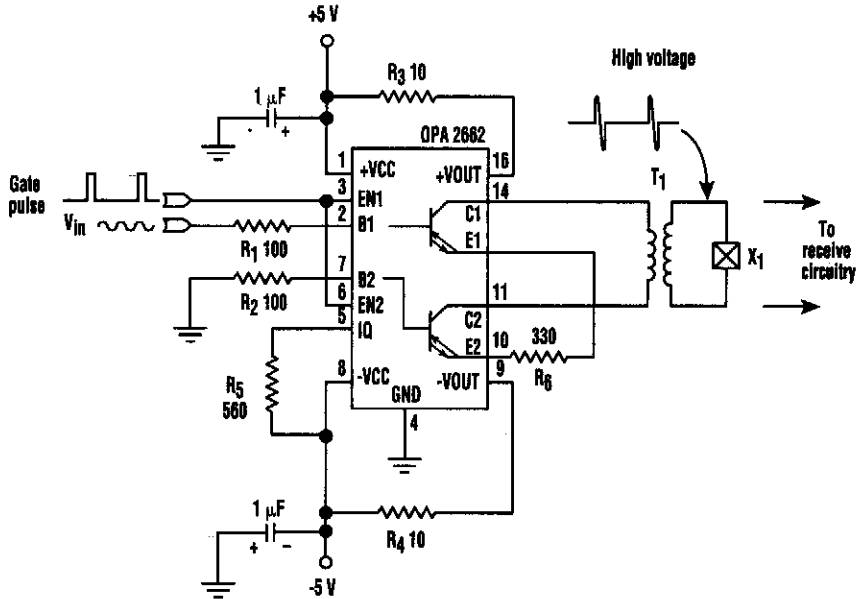

ELECTRONIC DESIGN

Fig. 52-19

This pulse-echo driver uses the OPA2662 dual operational transconductance amplifier (OTA) from Burr-Brown (the receive circuitry isn't shown). The OTA is preferable over an op amp for driving low impedances because it provides a current output rather than a voltage output.

Ultrasonic pulse-echo applications often incorporate a transformer-coupled crystal to obtain a high-voltage pulse because the echo can be orders of magnitude smaller in amplitude. The transformer turns ratio also provides tuning at the resonant frequency of the crystal, which usually means a relatively low-impedance primary winding.

An operational transconductance amplifier (OTA) is preferred over an op amp to drive such a low impedance. One particular application involves a pulse-echo driver circuit using the OPA2662.

SIMPLE PSEUDORANDOM VOLTAGE SOURCE

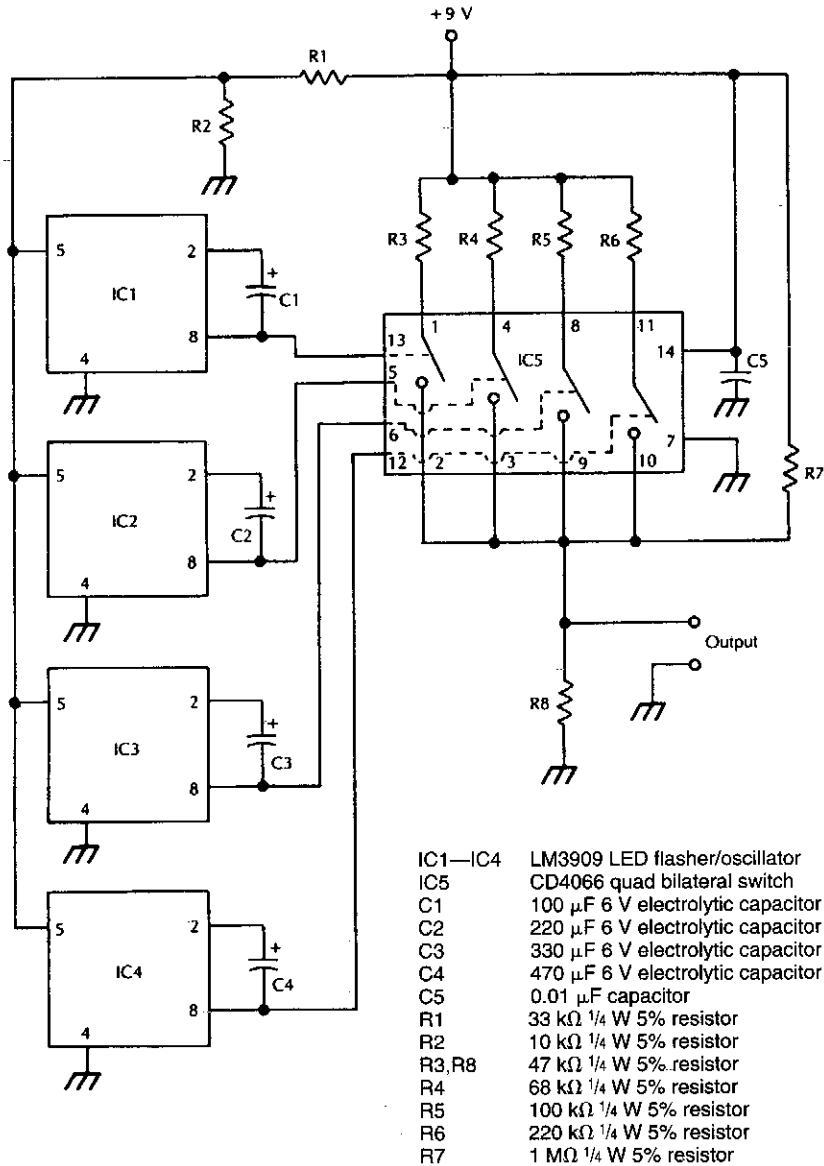

McGRAW-HILL

Fig. 52-20

An approximation to a pseudorandom voltage is produced by combining the outputs of four low-frequency oscillators with 0.3, 0.6, 0.9, and 1.4 Hz frequencies. The summing network is a quad bilateral switch and resistor network.

TV HORIZONTAL DEFLECTION CIRCUIT

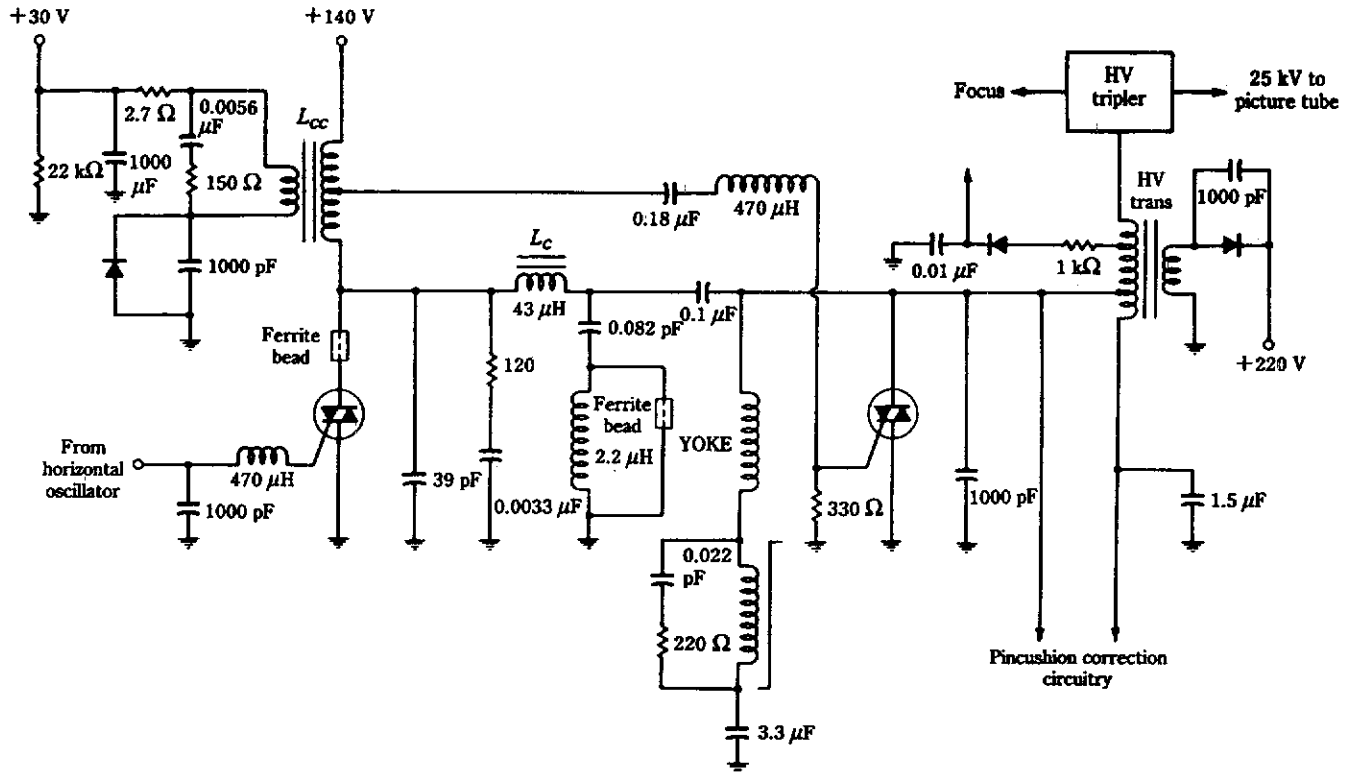

McGRAW-HILL

Fig. 52-21

The circuit illustrates the method of using two SCR devices in a TV horizontal deflection application. This circuit was widely used by certain TV manufacturers as an alternate to the vacuum tube or transistor deflection circuit.

MUTING CIRCUIT

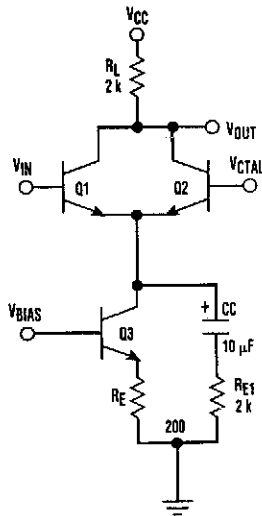

Notes :

Q1, Q2 should be matched ;

Q3 is not critical .

$$V_{CTRL} \text{ low, } \frac{V_{OUT}}{V_{IN}} = -\frac{R_L}{R_{E1}}$$

$$V_{CTRL} \text{ high, } \frac{V_{OUT}}{V_{IN}} \rightarrow 0.$$

$$V_{OUTDC} \rightarrow \text{constant}.$$

ELECTRONIC DESIGN

Fig. 52-22

The circuit operates as follows: The signal is input to V_{in} and a dc control voltage is applied to V_c . V_{bias} determines the desired bias point current. Assuming the following component and voltage values:

$$V_{cc} = 7.6 \text{ Vdc}$$

$$V_{bias} = 1 \text{ Vdc}$$

$$V_{in} = 1 \text{ Vp-p, ac signal centered about } 3.8 \text{ Vdc bias}$$

$$R_L = 2 \text{ k}\Omega$$

$$R_E = 200 \text{ k}\Omega$$

$$R_{E1} = 2 \text{ k}\Omega$$

Q3 bias current is 1 mA, and dc output voltage is about 5.8 V with an ac gain of about -1 , Q1 and Q2 form a current switch and Q3 acts as a constant current source.

For unmuted operation, $V_c = 0 \text{ Vdc}$, and all of the bias current flows through Q1. Consequently, the circuit operates as a normal common emitter stage, with ac gain $= -R_L/R_{E1}$. When $V_c = 5 \text{ Vdc}$, all of the bias current flows through Q2, reducing the signal gain to zero. However, because the same dc current flows through R_L in both cases (unmuted and muted), the bias point at the output remains fixed. The C_c/R_{E1} network is required to bypass the Q3 current source (which is a high impedance) to achieve a low ac impedance at the emitter of the Q1 common emitter stage during unmuted operation. C_c is chosen to be a short circuit at signal frequencies of interest. The circuit works best if the Q1 and Q2 pair is matched. Typical change in the output dc voltage from unmuted to muted condition is $<5 \text{ mVdc}$.

R_L , R_E , and V_{bias} are chosen for desired dc operating conditions and signal dynamic range. V_{bias} can be generated via a V_{cc} voltage divider. The signal at V_{in} can be ac coupled, but a bias circuit must be added to Q1's base to generate a dc component. R_{E1} is chosen for desired ac gain. V_{in} must be centered about a dc component, and, to assure proper switching action, $V_{CT}R_L$ must be higher than V_{in} by an amount greater than one V_{BE} drop.

SIMPLE REMOTE GAIN CONTROL

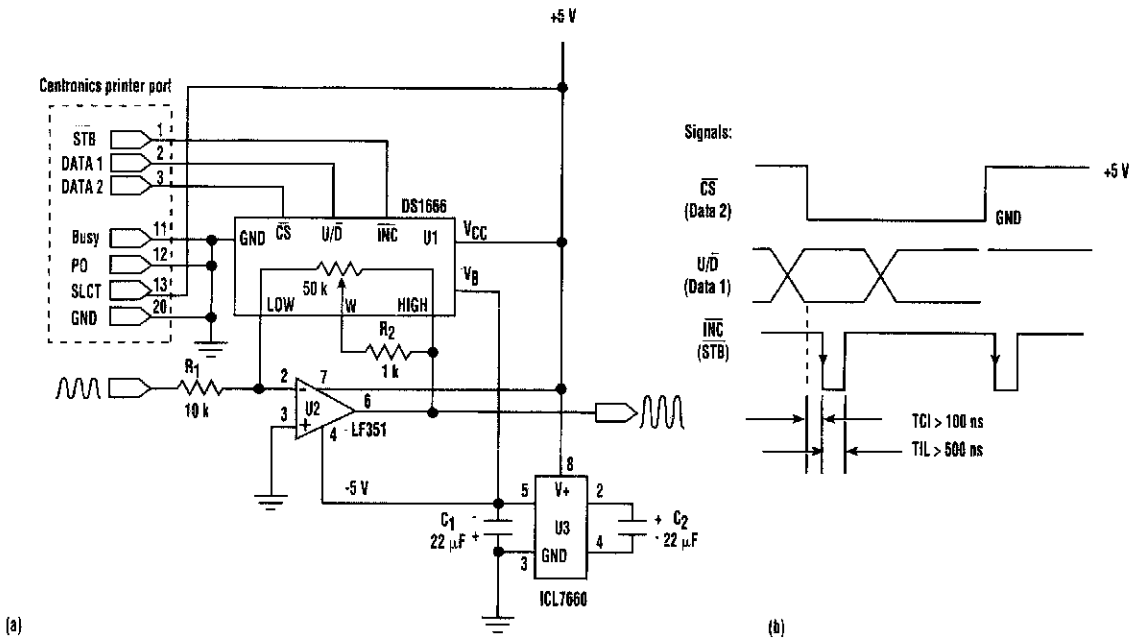

REMOTE CONTROL OF GAIN using a digital audio resistor is possible with this circuit scheme (a). It requires only three ICs and a single 5-V supply to provide gain control via a PC printer port. The input signals to U1 from the printer port are given (b).

```

100 REM LFGAIN.BAS
120 REM GAIN CONTROL FROM PC PRINTER PORT
200 OPEN "LPT1:" FOR OUTPUT AS #1
210 INPUT "GAIN UP OR DOWN (1/0): "; X
220 IF X<0 OR X>1 THEN GOTO 210
300 REM
310 INPUT "NUMBER OF COUNTS: "; C
320 REM SUBROUTINE WOULD START HERE
330 PRINT #1, CHR$(X);
340 C = C - 1 : IF C>0 THEN GOTO 330
350 PRINT #1, CHR$(3)
360 GOTO 210
380 RETURN
    
```

The listing is a test program that demonstrates circuit operation using an IBM-compatible PC. To form a subroutine for a main program, use lines 330 to 380, deleting line 360. The calling program then would pass values for X (wiper direction) and C (number of increments).

LOOP OSCILLATOR ELIMINATOR

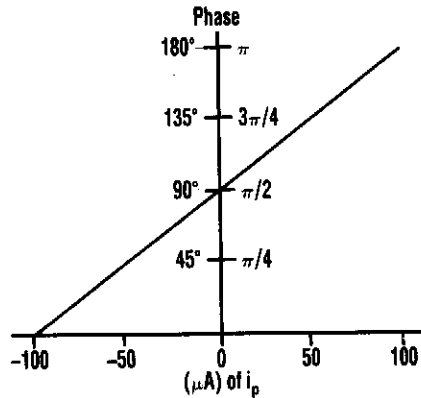
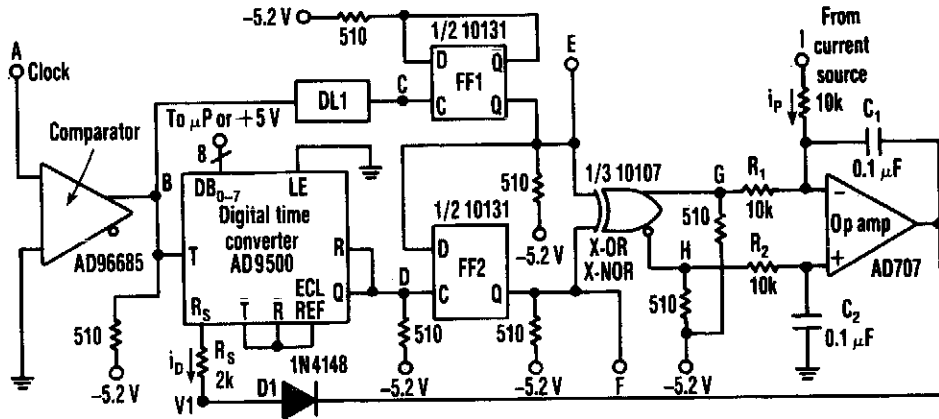

ELECTRONIC DESIGN

Fig. 52-24

This circuit uses negative feedback to a digital-to-time converter, and can supply a current-controlled delay to replace the oscillator in a phase-locked loop that handles input frequencies from 40 kHz to 40 MHz.

A current sourced into the inverting input of the op-amp integrator's summing node can phase shift the pulses at F in relation to those at E by up to 180°.

1-A VOLTAGE FOLLOWER

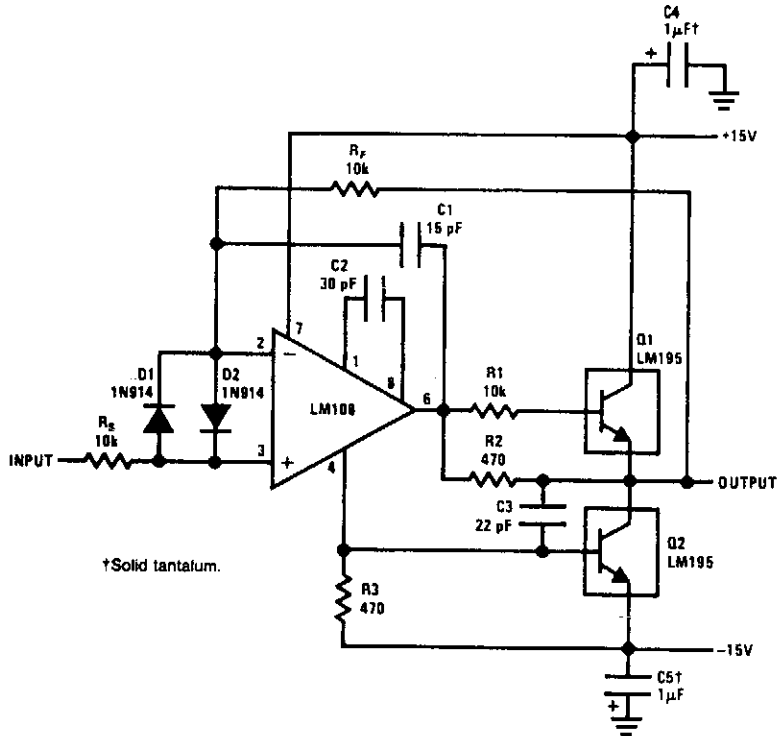

NATIONAL SEMICONDUCTOR

Fig. 52-25

This power voltage follower is good to 300 kHz.

ELECTRONIC FISH LURE

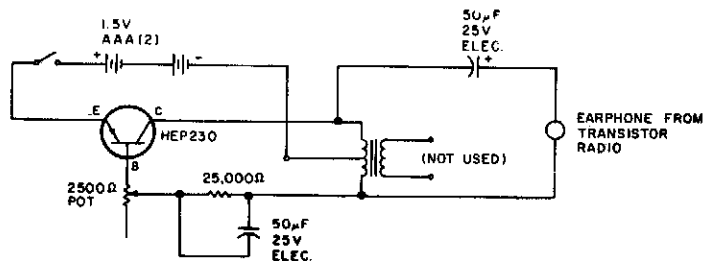

73 AMATEUR RADIO TODAY

Fig. 52-26

The click-click sound lures fish to the vicinity, where your bait or lure can do the rest. The transformer is a subminiature type with a 500-Ω, center-tapped primary and a 3.2-Ω secondary. Put the circuit in a watertight container and lower it into the water.

HEARTBEAT TRANSDUCER

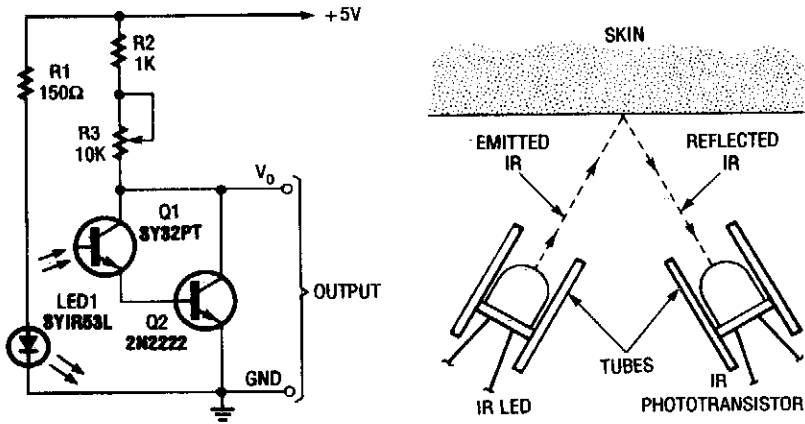

POPULAR ELECTRONICS

Fig. 52-27

A simple heart-beat transducer can be made from an infrared LED and an infrared phototransistor. It works because skin acts as a reflective surface for infrared light. The IR reflectivity of one's skin depends on the density of blood in it. Blood density rises and falls with the pumping action of the heart. So the intensity of infrared reflected by the skin (and thus transmitted to the phototransistor) rises and falls with each heartbeat.

CONTACT DEBOUNCER

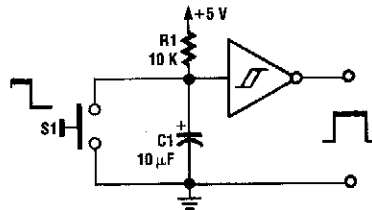

ELECTRONICS NOW

Fig. 52-28

A contact debouncer using a Schmitt trigger, such as a TTL7414, provides a "clean" pulse from a switch contact closing.

POSITIVE FEEDBACK CABLE TERMINATOR

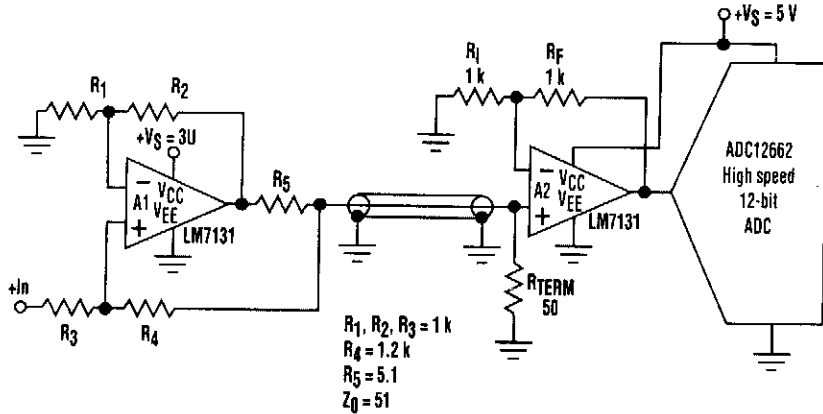

ELECTRONIC DESIGN

Fig. 52-29

Positive feedback along with a series output resistor can provide a controlled output impedance from an op-amp circuit. The circuit is useful when driving coaxial cables that must be terminated at each end in their characteristic impedance, which is often 50 Ω . Adding a 50- Ω series resistor on the op amp's output obviously reduces the available signal swing.

×10 FREQUENCY MULTIPLIER

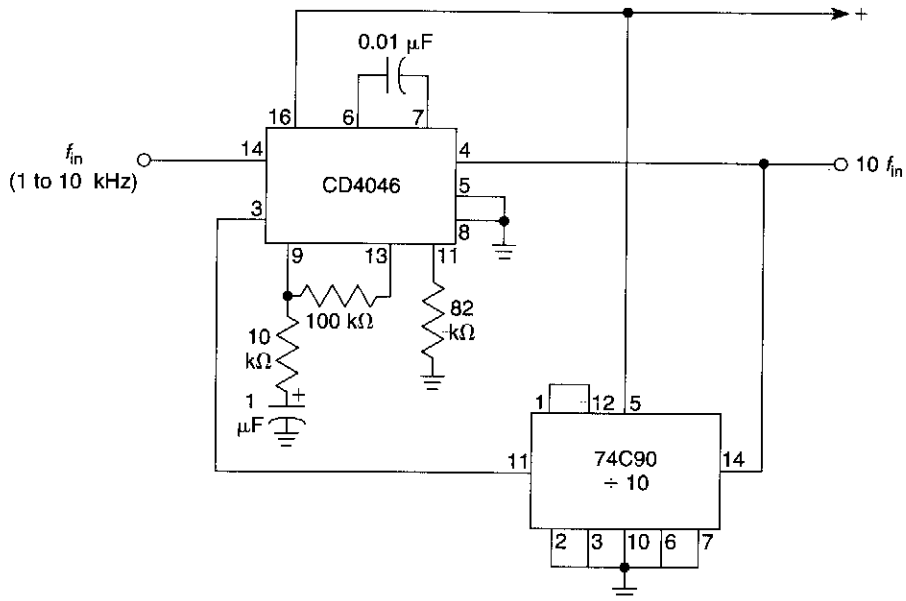

WILLIAM SHEETS

Fig. 52-30

In this circuit, the CD4046 is set up so that the V_{CO} operates at 10 to 100 kHz. The output pin (4) is fed back to a $\div 10$ counter. When the input frequency is $\frac{1}{10}$ the output, lockup will occur.

JACOB'S LADDER

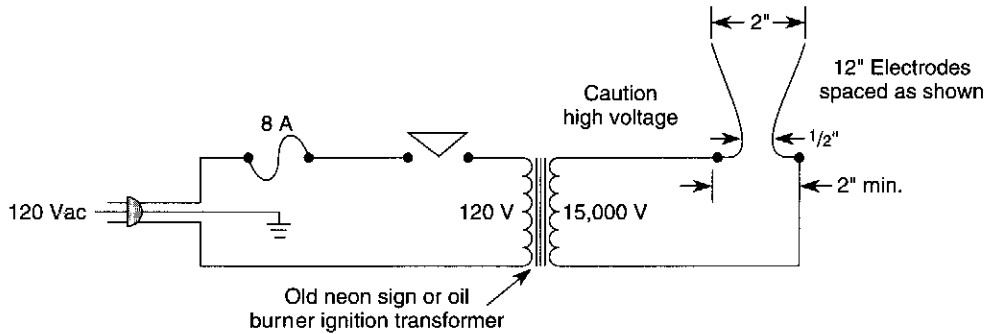

WILLIAM SHEETS

Fig. 52-31

A "Jacobs Ladder" can be made from an old neon sign or oil burner ignition transformer. A rating of 12 to 15 kV at 20 to 30 mA will be adequate. Make sure to mount the electrodes to a pair of insulators, at least 2" apart, and bent and spaced, as shown. The ladder should be enclosed in a clear plastic housing to prevent accidental contact with the high voltage and to ensure a stable arc. Vent holes should be placed top and bottom to allow gases to escape.

MASTER-SLAVE DEVICE ERROR CHECKER

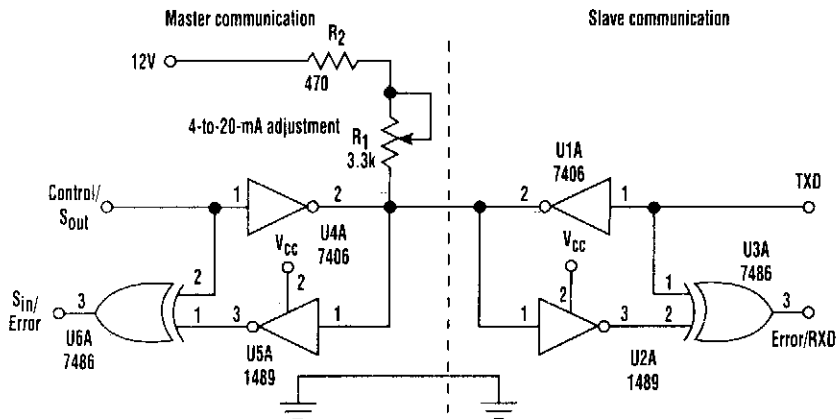

ELECTRONIC DESIGN

Fig. 52-32

An error-check mechanism introduced into master and slave communication devices can indicate mismatches when both the master and slave start sending data simultaneously. The error flag goes high and indicates a mismatch in the data.

The master is the one that can interrupt the communication from a device at the other end and force it to listen. It does this forcing a low voltage level over the communication line by raising the control line to a high level. This inhibits data flow over the lines from the slave device. As a result, the slave turns into a listen mode (not a hardware feature, but rather incorporated in the software). The slave device can transmit the data after communication from the master device ceases.

GROUND LOOP PREVENTER

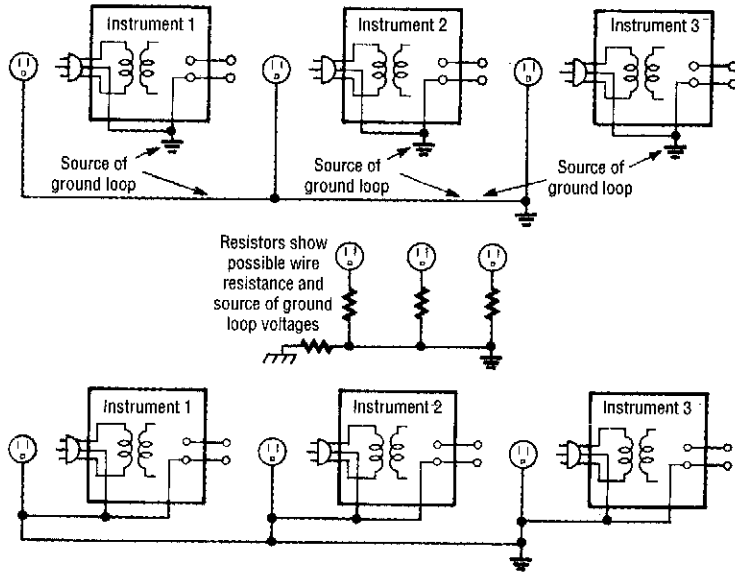

ELECTRONICS NOW

Fig. 52-33

Ground loops are caused by improper grounding. Ground-loop voltages can interfere with test measurements because the voltages in a ground loop can be larger than the signals you're trying to measure. To prevent ground loops, use two wire plugs to provide the line power to the test instruments and a separate wire to bring the input grounds of the instruments to a common ground.

DUAL TONE GENERATOR FOR AUDIO SERVICING

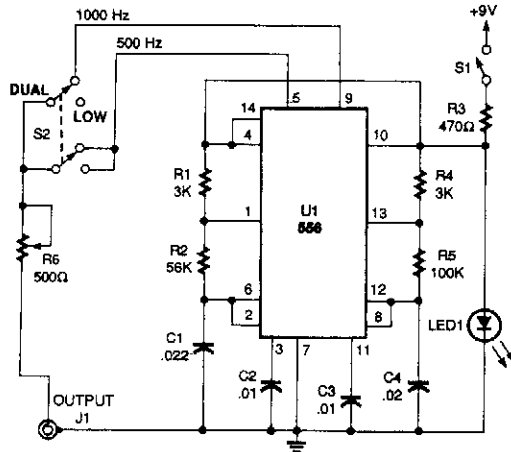

POPULAR ELECTRONICS

Fig. 52-34

This dual-tone generator can insert a distinctive tone in the audio section of a circuit under test. That way, you can work your way back from the speaker, stage-by-stage, to locate a faulty section.

DIODELESS PEAK-HOLD CIRCUIT

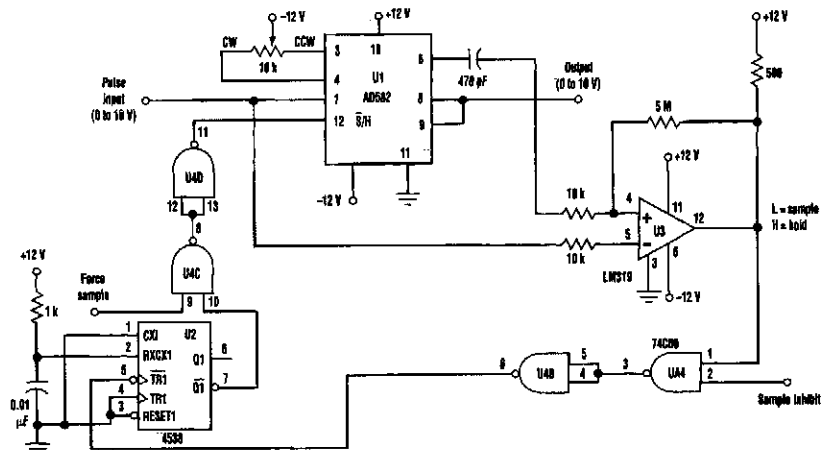

ELECTRONIC DESIGN

Fig. 52-35

The input pulse is fed into the sample-and-hold amplifier (an inexpensive AD582), as well as the comparator U3. The SHA's output also is fed into the comparator. If the input pulse is higher in amplitude than the SHA's output, the comparator output goes low and the 4538 one-shot produces a 10- μ s pulse that is fed back to cause the SHA to sample and then hold the voltage. Subsequent input voltages that are less than the held value won't cause the one-shot to fire again.

Gates U4A and U4B are used to inhibit the sampling when necessary. Gates U4C and U4D, at the one-shot's output, can force the AD 582 into the sample mode. This feature is useful to reset the output to zero by forcing a sample when the input to the AD582 is zero. The polarity of the peak-hold circuit can be easily changed from positive-to-negative peak hold by reversing the inputs of the comparator.

53

Mixer Circuits

The sources of the following circuits are contained in the Sources section, which begins on page 707. The figure number in the box of each circuit correlates to the entry in the Sources section.

Simple Audio Mixer
Op-Amp Audio Mixer

SIMPLE AUDIO MIXER

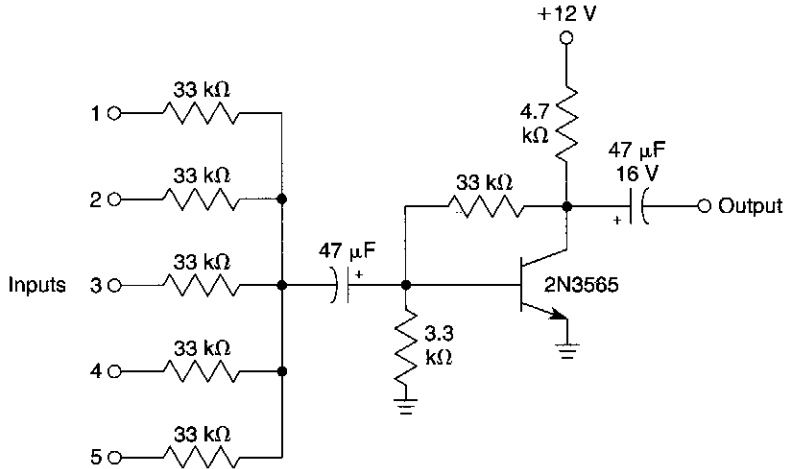

WILLIAM SHEETS

Fig. 53-1

A single transistor is used as an audio mixer, the transistor serving as a feedback amplifier.

OP-AMP AUDIO MIXER

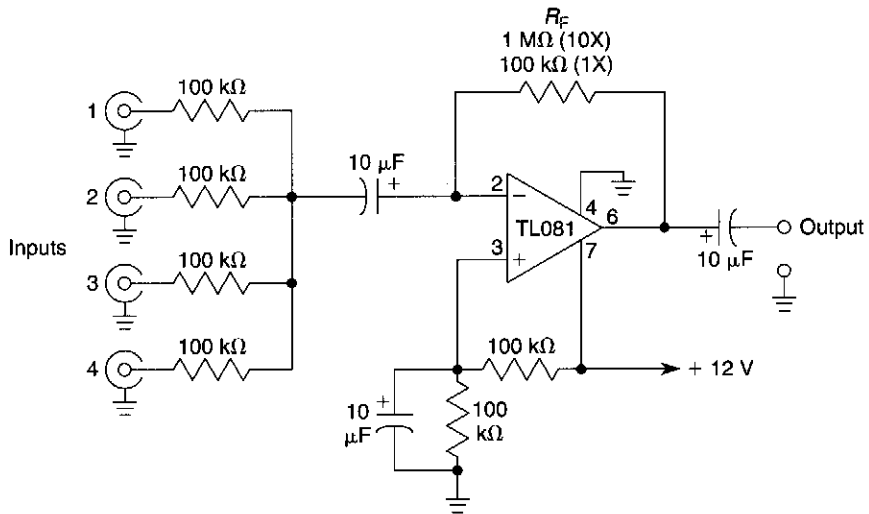

WILLIAM SHEETS

Fig. 53-2

This circuit will mix several audio signals to a common output. R_F can be made $1\text{ M}\Omega$ for $10 \times$ (20 dB) or $100\text{ k}\Omega$ for unity gain.

54

Model and Hobby Circuits

The sources of the following circuits are contained in the Sources section, which begins on page 707. The figure number in the box of each circuit correlates to the entry in the Sources section.

Model Railroad Crossing Flasher
Model Railroad Track Control Signal

MODEL RAILROAD CROSSING FLASHER

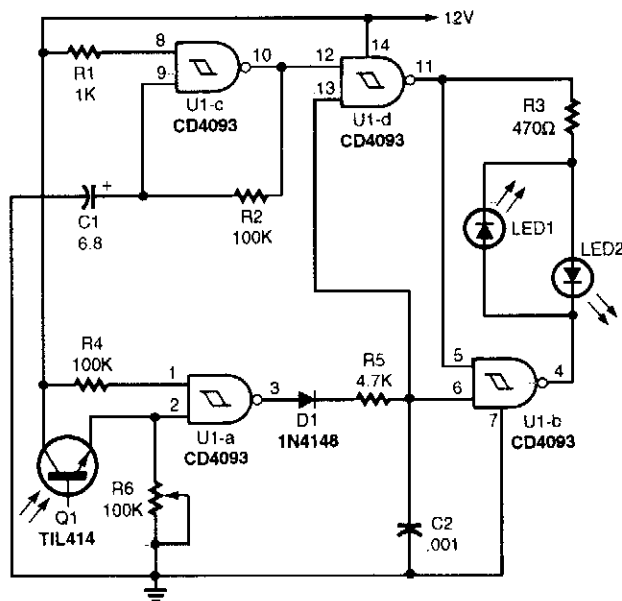

POPULAR ELECTRONICS

Fig. 54-1

Gate U1-c is set up as an oscillator whose frequency is determined by C1 and R1. Gates U1-b and U1-d are set up as an RS flip-flop that is gated on by U1-a. Gate U1-a in conjunction with Q1 operates as the control gate for the flip-flop. Components D1, C2, and R5 act as a delay circuit to compensate for any light getting through the gaps between cars as they pass over the phototransistors. The light-emitting diodes are connected so that they operate alternately, depending on the outputs of U1-d and U1-b.

Basically, R6 is adjusted so that ambient room-light striking Q1 (and any other phototransistors connected in series) keeps the output of U1-a at pin 3 low. When a car passes over the phototransistor, which is installed between ties in the track, pin 3 goes high, allowing a high to be placed on pins 5 and 13. That allows the high output of U1-c at pin 10 to enable pin 12, which in turn allows pin 11 to go low. That makes a complete path for LED2 to operate. When pin 10 goes low, pin 11 goes high. That makes pin 5 high, and thus, enables pin 4 to go low and completes the circuit for LED1. That alternates the LEDs, which are installed in a railroad-crossing signal.

MODEL RAILROAD TRACK CONTROL SIGNAL

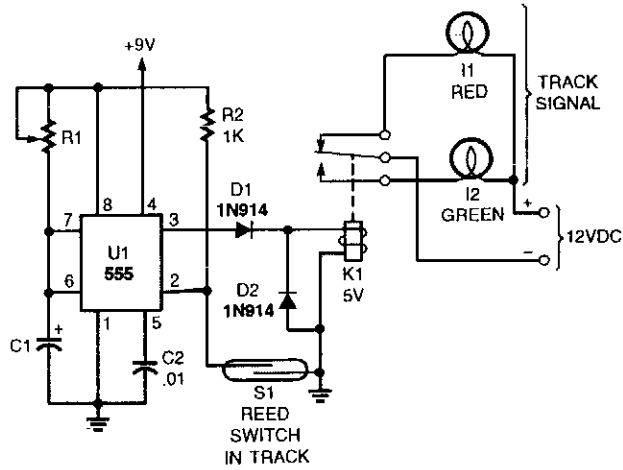

RED-LAMP ON TIME (SECONDS)		
R1 (KILOHMS)	C1 = 10 μ F	C1 = 100 μ F
100	2	16
220	3	32
470	6	70
1000	15	175

POPULAR ELECTRONICS

Fig. 54-2

When a train passes S1 (a red switch), a small magnet glued to the underside operates S1 and causes U1 to generate a pulse, activating relay K1 and changing the signal from green to red. After a time determined by R1 and C1 (see table), the relay de-energizes and the signal goes back to green.

55

Modulator Circuits

The sources of the following circuits are contained in the Sources section, which begins on page 707. The figure number in the box of each circuit correlates to the entry in the Sources section.

Varactorless HF Modulator
Modulator for Video
Digital Pulse-Width Modulation Circuit
Four-Quadrant Multiplier as DSB Modulator
Pulse-Width Modulator
Linear (AM) Amplitude Modulator
Video Modulator Hookup

VARACTORLESS HF MODULATOR

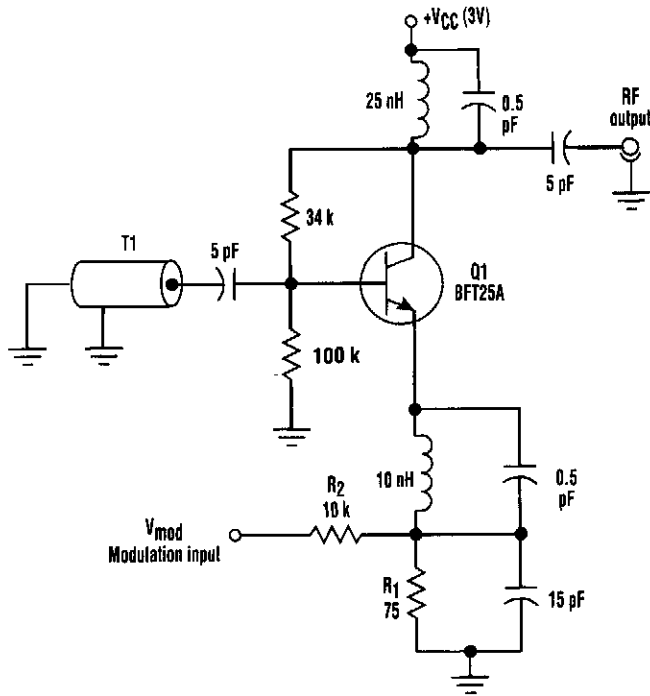

ELECTRONIC DESIGN

Fig. 55-1

Traditionally, high-frequency oscillators are frequency-modulated by using a varactor. However, varactors usually require a large voltage change to achieve a reasonable capacitance change—a problem in many battery-powered systems.

Such a problem can be overcome by employing base-charging capacitance modulation. Resistor R1 establishes Q1's current, and R2 allows control of the collector bias current by V_{mod} . The transmission line (T1) in the negative resistance-type oscillator determines the frequency of oscillation. T1 is a high-quality, low-loss, ceramic coaxial shorted quarter-wave transmission line. Under proper terminal impedances, a negative resistance is "seen" at Q1's base. T1 reacts with this negative resistance to produce sustained oscillations.

Frequency modulation is accomplished by changing Q1's collector bias current and thus changing Q1's base-charging capacitance. This effect is "seen" at Q1's base and causes a frequency shift in the resonator's quarter-wave node.

MODULATOR FOR VIDEO

Sources: SAWFs

Crystal Technology, Inc.
1035 E. Meadow Circle
Palo Alto, CA 94303

Kyocera International, Inc.
8611 Balboa Ave.
San Diego, CA 92123

MuRata Corp. of America
1148 Franklin Rd. S.E.
Marietta, GA 30067

CRYSTALS

Saronix
4010 Transport at San Antonio Rd.
Palo Alto, CA 94303

COILS

Toko America, Inc.
5520 W. Touhy Ave.
Skokie, Ill. 60077

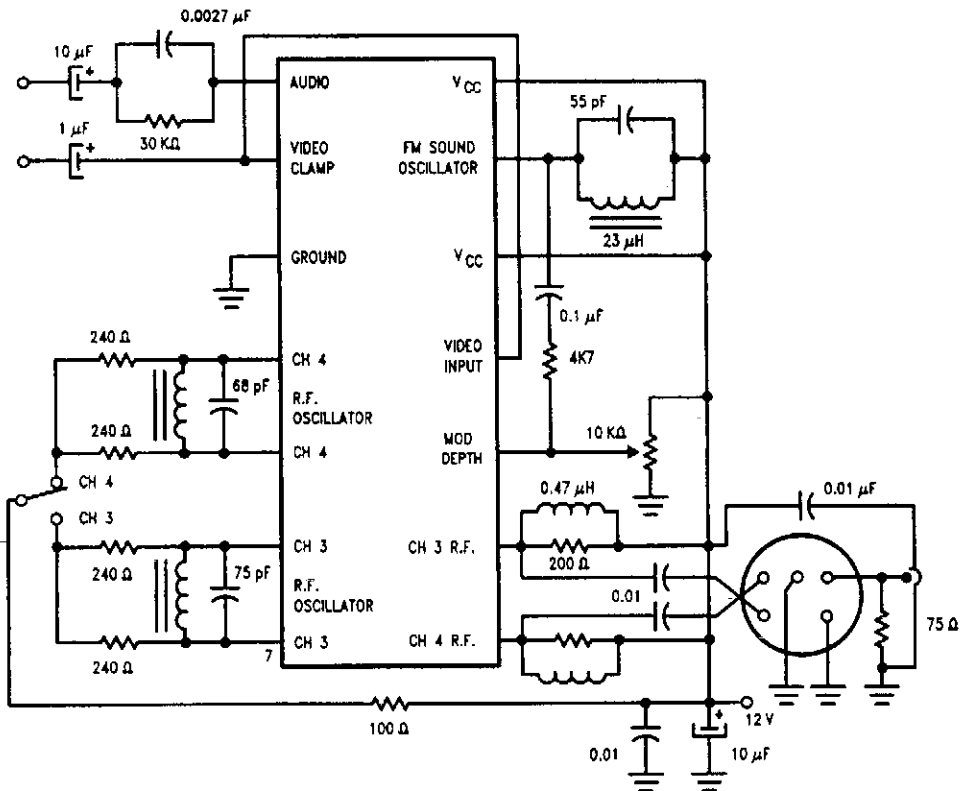

NATIONAL SEMICONDUCTOR

Fig. 55-2

This circuit uses an LM2889 and a saw filter for use as a TV modulator.

DIGITAL PULSE-WIDTH MODULATION CIRCUIT

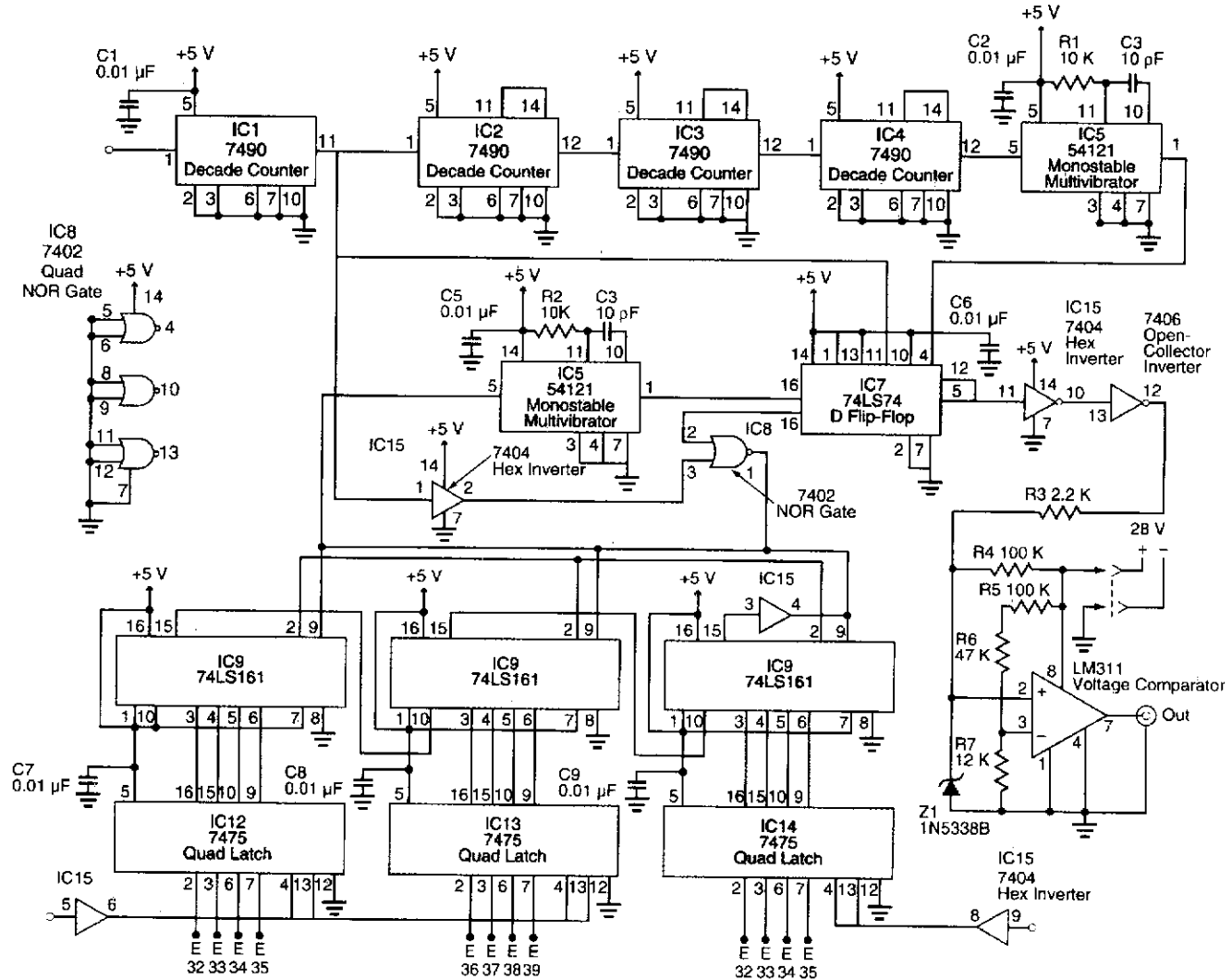

DIGITAL PULSE-WIDTH MODULATION CIRCUIT (Cont.)

This circuit incorporates low-power Schottky transistor/transistor-logic (TTL) devices in critical high-speed parts. The 5-MHz clock signal is converted to a 1-MHz signal by a 7490 decade counter configured to divide by 5. The 1-MHz signal is sent, via a clock synchronizer, to a three-stage binary divider that consists of three cascaded 74LS161 binary dividers. The synchronizer consists of a 74LS74 D flip-flop, a 7404 inverter gate, and a 7402 NOR gate. The dividers are programmed from the STD bus by means of three 7475 quad latches; this makes it possible to program the frequency division from 1 to 4096 (12 bits).

The 1-MHz signal is also divided by 1000 by use of three cascaded 7490 decade counters, each configured to divide by 10; this provides a 1-kHz signal, which is sent to a 54121 monostable multivibrator configured to provide a 0.1- μ s pulse, bombarded with an ion beam source in preparation for the materials about to be deposited. While the surface is bombarded with an ion beam, an electron beam source is activated so that a layer of fused silica is vapor-deposited to a total desired thickness value (typically, 1 micron or 10,000 Å). The layer of fused silica serves as a surface stabilization layer for the next step.

A metal mask with an aperture in the specified pattern of the sensor film is placed on the surface at the specified sensor location. The surface area exposed through the mask is cleaned by ion-beam bombardment for a predetermined time. Then as the bombardment continues, a metal (typically, nickel, platinum, and/or palladium) is vapor-deposited through the mask from the electron-beam source to form the sensor film. Deposition is continued until the thickness of the film reaches the value specified in the particular sensor design. A representative value for a nickel sensor film is 2500 Å.

Next, a pattern for thin film leads is defined by taping directly on the surface of the model with Kapton (or equivalent) polyimide tape. The thin film leads are fabricated by a combination of ion-beam bombardment and electron-beam vapor deposition like that used to deposit the sensor film. The metal vapor deposited in this step is typically copper, gold, or aluminum. A typical thickness for copper leads on the nickel sensor film is about 10,000 Å.

FOUR-QUADRANT MULTIPLIER AS DSB MODULATOR

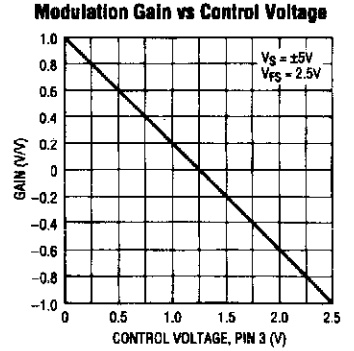
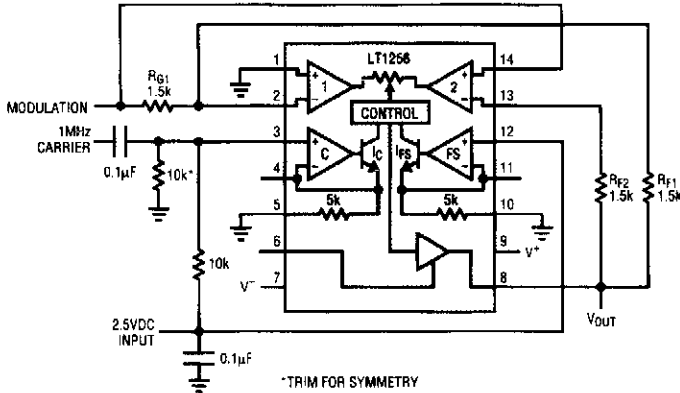

LINEAR TECHNOLOGY

Fig. 55-4

PULSE-WIDTH MODULATOR

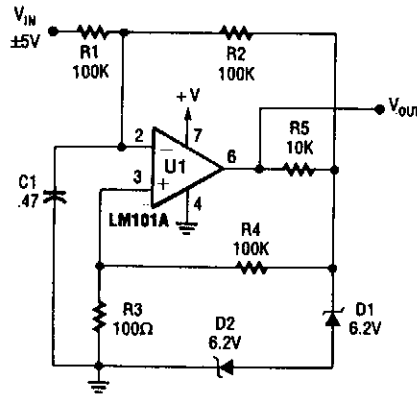

POPULAR ELECTRONICS

Fig. 55-5

LINEAR (AM) AMPLITUDE MODULATOR

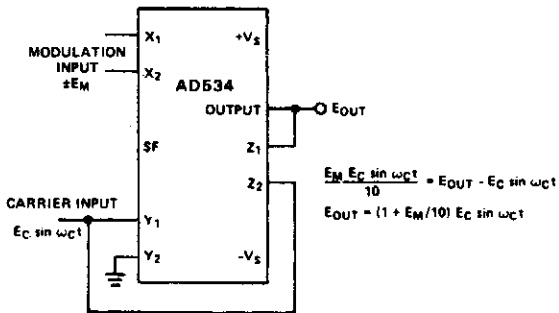

This is a very simple amplitude modulator. It makes use of the Z2 terminal to add the carrier directly to the output, thus bypassing the multiplier for zero-modulation input. It has the advantage of allowing operation from a differential modulation input.

ANALOG DEVICES

Fig. 55-6

VIDEO MODULATOR HOOKUP

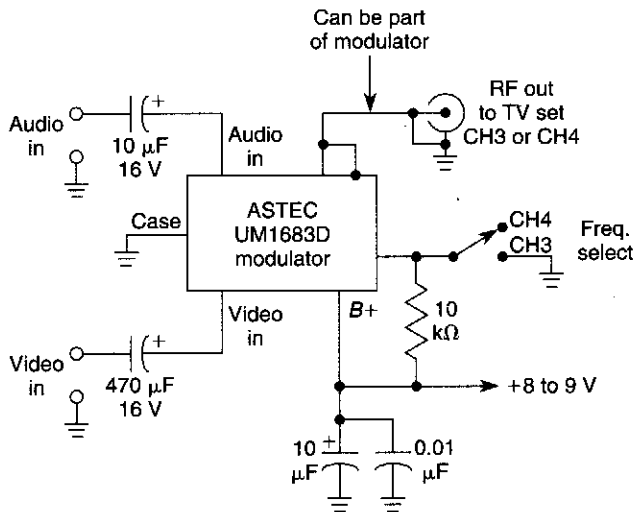

WILLIAM SHEETS

Fig. 55-7

This circuit uses an ASTEC UM1683D, but it is typical of many RF video modulators used in VCRs and satellite receivers.

56

Morse Code Circuits

The sources of the following circuits are contained in the Sources section, which begins on page 707. The figure number in the box of each circuit correlates to the entry in the Sources section.

Active CW Audio Filter

Morse Messenger

CW Identifier with Sine-Wave Audio Output

Simple Code Practice Oscillator

ACTIVE CW AUDIO FILTER

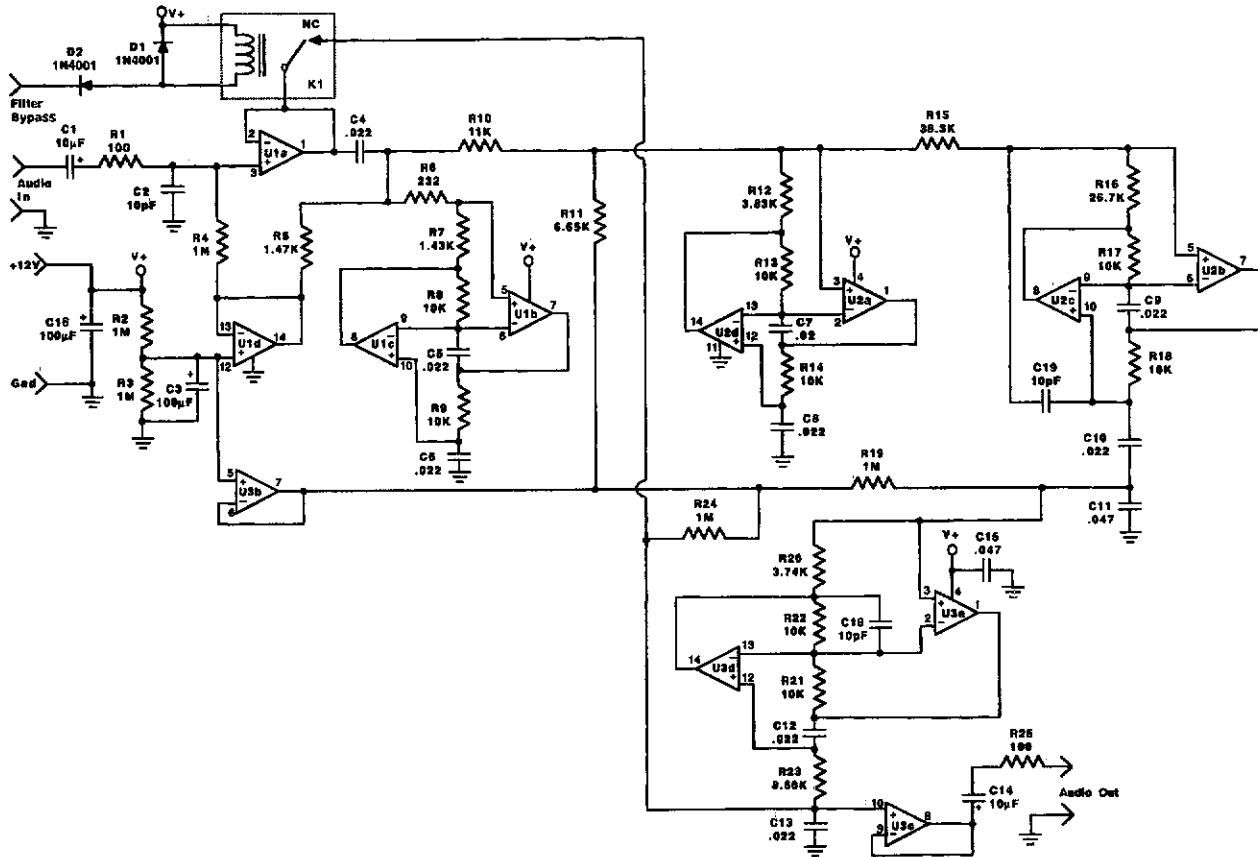

The audio filter shown has a bandpass of 200 Hz centered on 700 Hz. Resistors are 1% tolerance and capacitors should be 5% tolerance.

MORSE MESSENGER

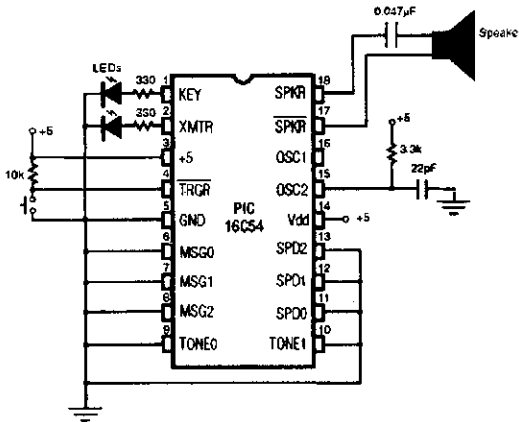

Set up as shown, the chip will play message no. 0 at 7 words per minute, lowest sidetone frequency (400 Hz). LEDs indicate oscillator warmup (XMTR) and keying (KEY).

MSG2	MSG1	MSG0	Message No.
0	0	0	0
0	0	1	1
0	1	0	2
0	1	1	3
1	0	0	4
1	0	1	5
1	1	0	6
1	1	1	7

		Sidetone
TONE1	TONE0	(Hz)
0	0	400
0	1	525
1	0	650
1	1	775

			Speed
SPD2	SPD1	SPD0	(WPM)
0	0	0	7
0	0	1	10
0	1	0	15
0	1	1	20
1	0	0	25
1	0	1	30
1	1	0	35
1	1	1	40

Simple hook-up diagram for the Morse Messenger chip. The table indicates the range of messages, sidetones, and keying speeds.

This keyer uses a PIC16C54 micro-controller to generate a Morse code message. The microcontroller must be programmed to suit users call IC or desired message.

MORSE MESSENGER (Cont.)

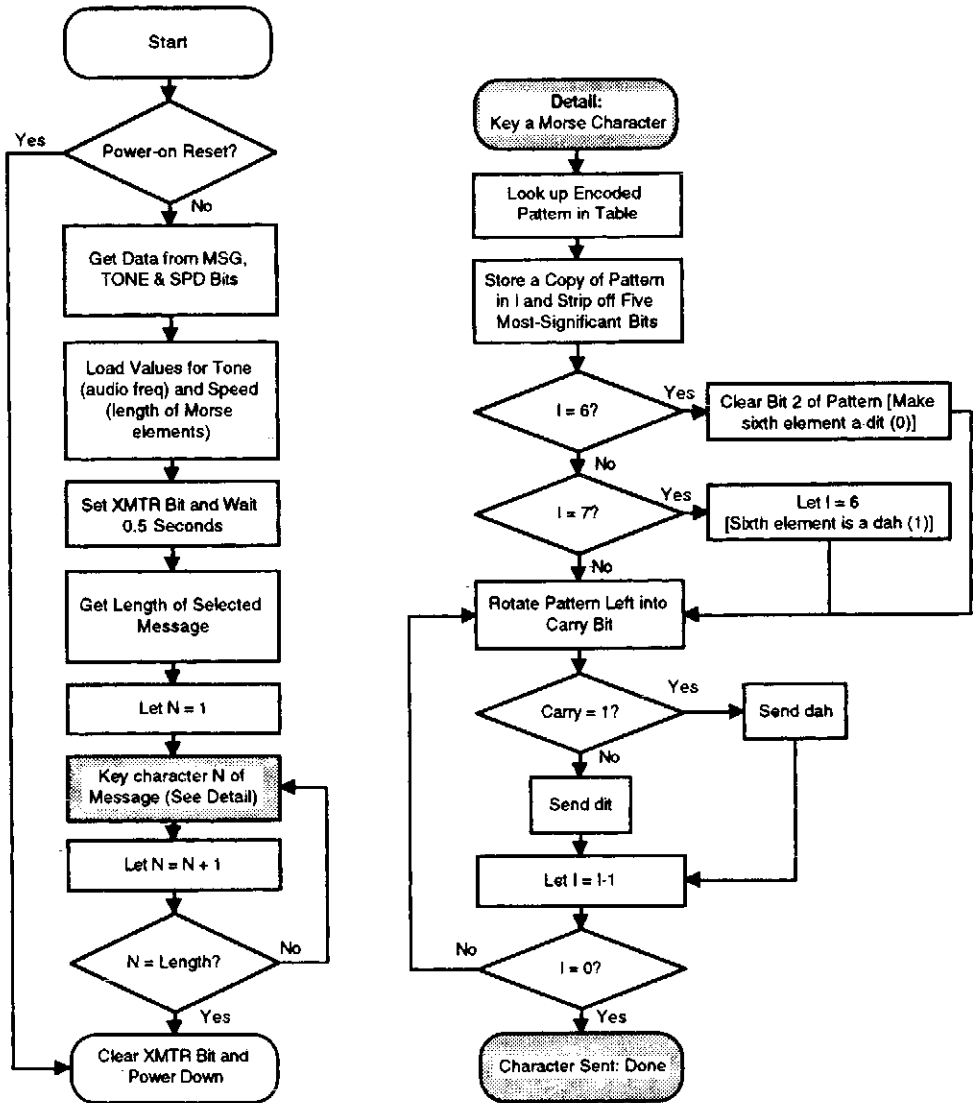

Logic of the Morse Messenger's program. This algorithm can be adapted to other devices with the help of the Morse encoding table.

CW IDENTIFIER WITH SINE-WAVE AUDIO OUTPUT

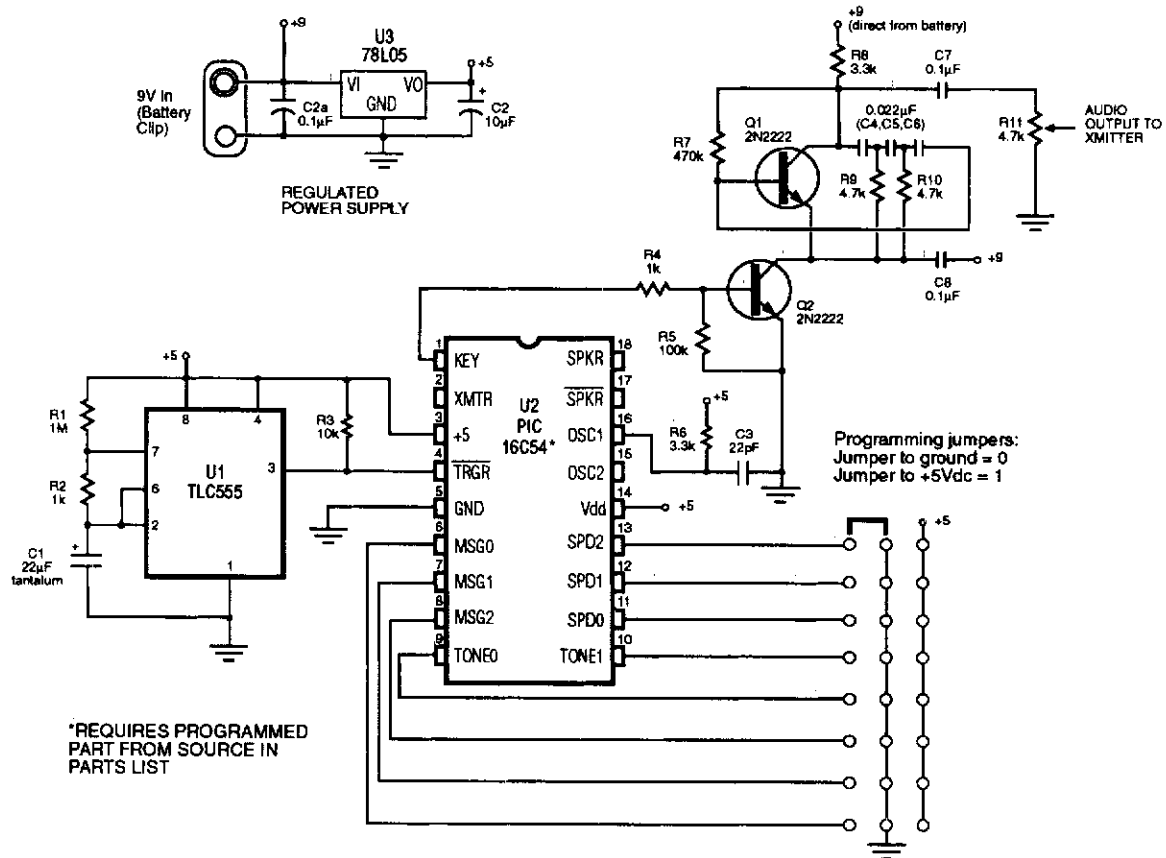

This identifier can be used to drive a hidden transmitter in a radio “fox hunt” activity, where the object is to locate a hidden transmitter.

SIMPLE CODE PRACTICE OSCILLATOR

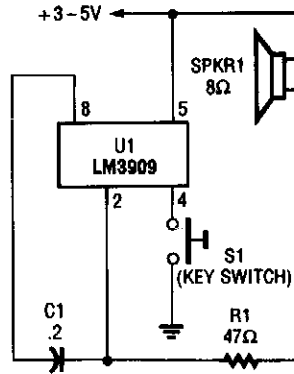

POPULAR ELECTRONICS

Fig. 56-4

With only a minor circuit change, the basic LM3909 oscillator configuration can be turned into a code-practice oscillator.

57

Motor-Control Circuits

The sources of the following circuits are contained in the Sources section, which begins on page 707. The figure number in the box of each circuit correlates to the entry in the Sources section.

Precise dc Motor Speed Controller
Accurate Motor Speed Control
Motor Direction Control Using Discrete Transistors
Long Time-Delay Motor-Control Circuit
Full-Wave Speed Control for Motors
SCR Motor Speed Control
Triac Motor-Control Circuit
Low-Voltage dc Motor-Speed Controller
Motor Direction Control

PRECISE dc MOTOR SPEED CONTROLLER

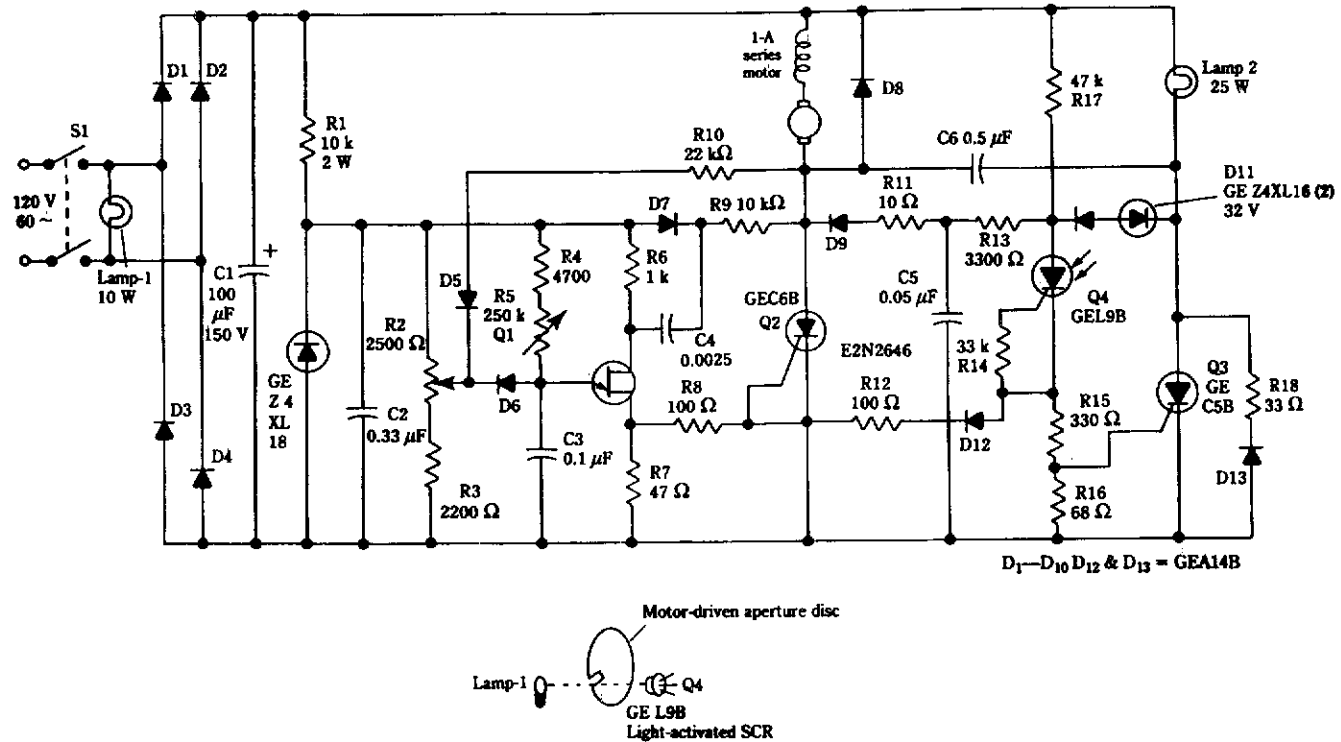

McGRAW-HILL

Fig. 57-1

A series dc motor can be made to have the same characteristics as an ac synchronous motor using this circuit. This control technique is useful where a constant motor speed is needed.

ACCURATE MOTOR SPEED CONTROL

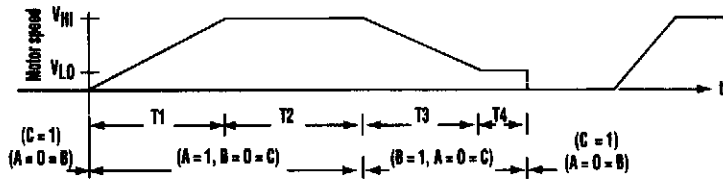
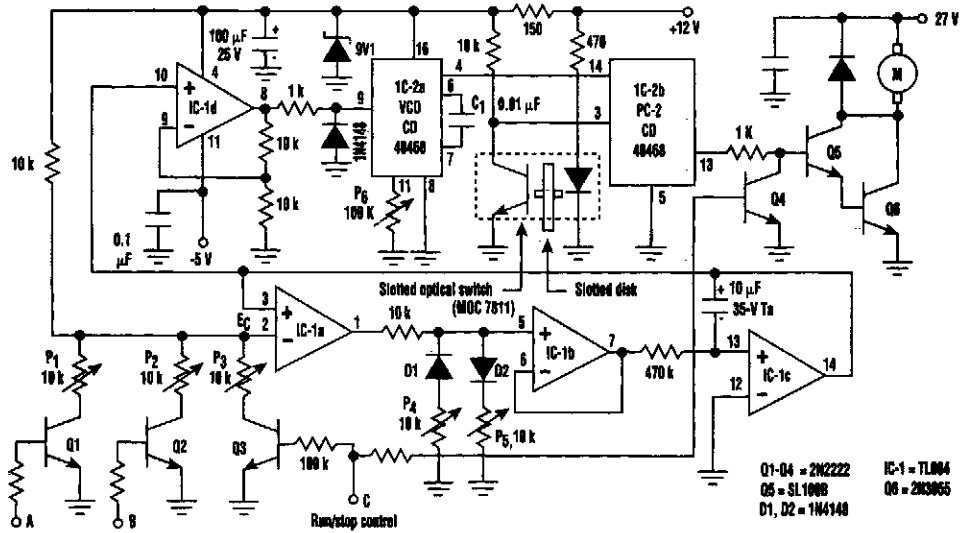

This motor velocity profile is provided by the controller. Note the smooth acceleration and deceleration profiles and the constant motor speed between the two ramps.

ELECTRONIC DESIGN

Fig. 57-2

This circuit can control dc motors used in machines that pull materials, such as wire, yarn, film, etc., from the supply rolls and rewind them onto smaller rolls. Its motor velocity profile is shown in the figure.

A lightweight disk with at least 32 slots is mounted on the motor shaft. It works in a slotted optical switch (MOC7811) to sense the motor speed. Phase comparator 2 (PC-2) of the phase-locked loop (IC-CD 4046B) compares the frequency (f_v) at the output of the VCO with the pulse rate (f_m) at the optical switch output. The PC-2 output drives the motor via the transistors when $f_v > f_m$, and removes the supply to the motor when $f_m > f_v$. The drive system quickly reaches an equilibrium condition when $f_m = f_v$.

Op amps IC-1a, 1b, and 1c form a tracking integrator whose output always smoothly reaches and remains at a voltage equal to the command voltage (E_c) presented at the inverting input of op-amp IC-1a. When the digital control inputs are set to ($A = 1, B = 0 = C$), the integrator generates a positive slope ramp that sweeps the VCO frequency and, thus, accelerates the motor. The acceleration rate and the constant speed V_{HI} can be adjusted by presets P4 and P1, respectively.

Similarly, when the inputs are set to ($A = 0 = C, B = 1$), the integrator generates a negative slope ramp that decelerates the motor. Presets P5 and P2 can be adjusted to set the required deceleration and the constant speed V_{LO} , respectively.

MOTOR DIRECTION CONTROL USING DISCRETE TRANSISTORS

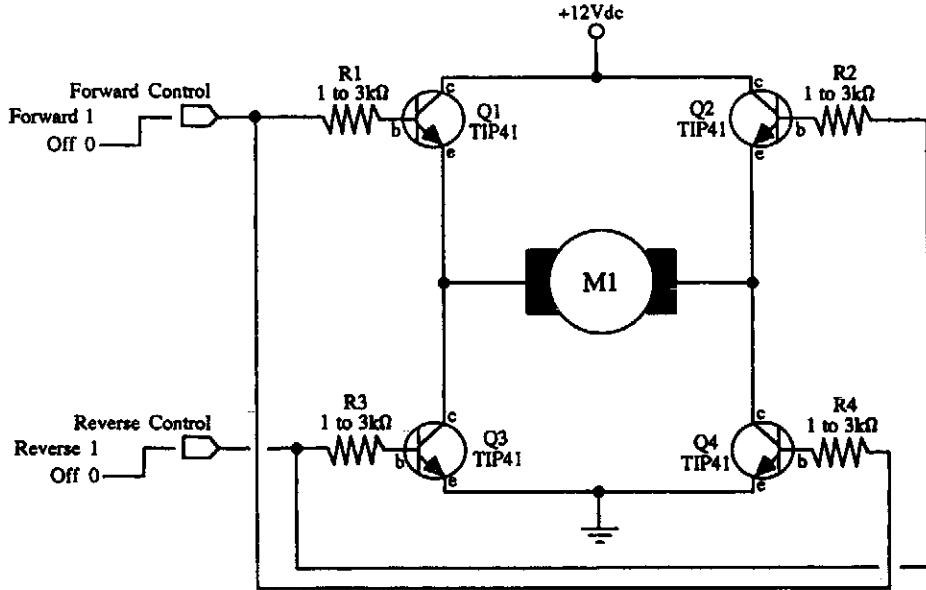

McGRAW-HILL

Fig. 57-3

For best operation, mount the transistors on heatsinks. The transistors specified are fine for small hobby motors, or up to about 6 volts dc and between 800 and 1000 mA. M1 is a small hobby motor.

LONG TIME-DELAY MOTOR-CONTROL CIRCUIT

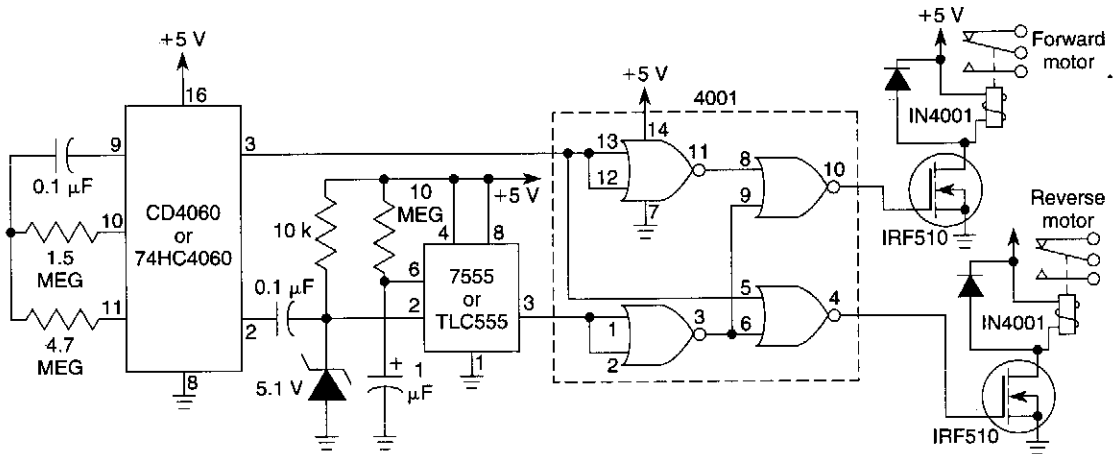

ELECTRONICS NOW

Fig. 57-4

Circuit controls forward and reverse motors. Every hour, one motor runs for 10 seconds.

FULL-WAVE SPEED CONTROL FOR MOTORS

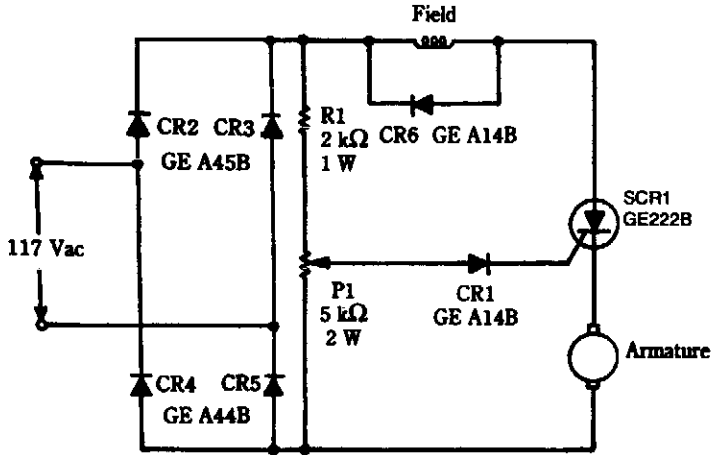

McGRAW-HILL

Fig. 57-5

A bridge rectifier provides pulsating dc to a universal motor, and the SCR is used as a phase-controlled switch. This circuit allows smoother operation of the motor at low speeds.

SCR MOTOR SPEED CONTROL

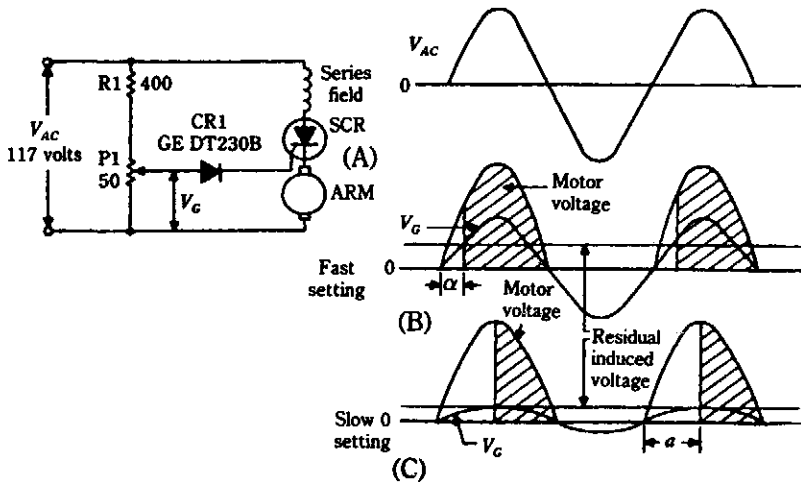

McGRAW-HILL

Fig. 57-6

An SCR is used in a phase-control type application to supply a variable pulsating dc voltage to a motor.

TRIAC MOTOR-CONTROL CIRCUIT

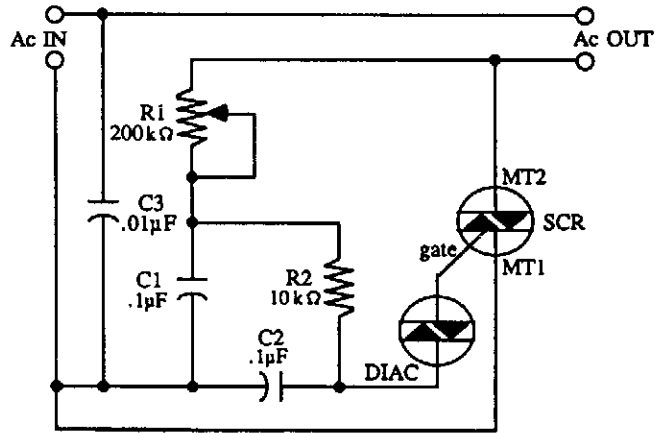

McGRAW-HILL

Fig. 57-7

An SCR-controlled ac motor control circuit. This is a full-wave circuit and is best used when the load remains constant.

LOW-VOLTAGE dc MOTOR-SPEED CONTROLLER

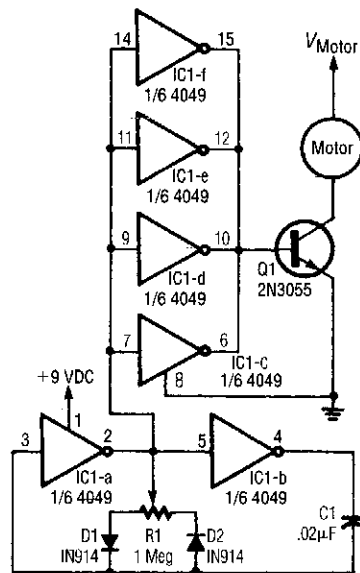

ELECTRONICS NOW

Fig. 57-8

This circuit varies the duty cycle, rather than the voltage. The two diodes control the positive and negative halves of the capacitor's charging cycle.

MOTOR DIRECTION CONTROL

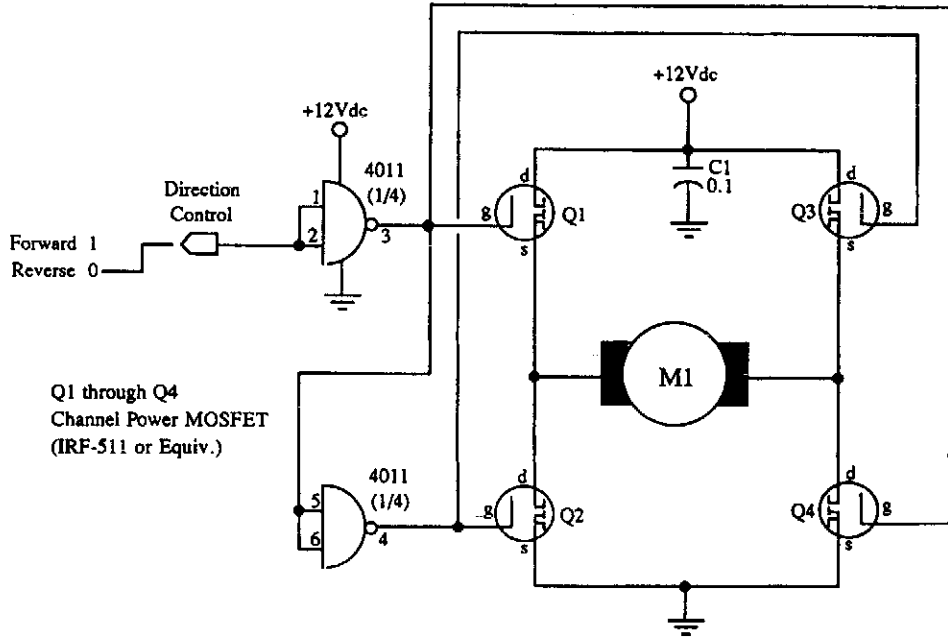

McGRAW-HILL

Fig. 57-9

M1 is a small hobby dc motor.

58

Multivibrator Circuits

The sources of the following circuits are contained in the Sources section, which begins on page 707. The figure number in the box of each circuit correlates to the entry in the Sources section.

- Astable Multivibrator with Starting Network
- Bistable Multivibrator
- Astable
- Astable with Variable Pulse Width
- One-Shot Multivibrator
- Basic 555 Astable Multivibrator
- Astable Multivibrator

ASTABLE MULTIVIBRATOR WITH STARTING NETWORK

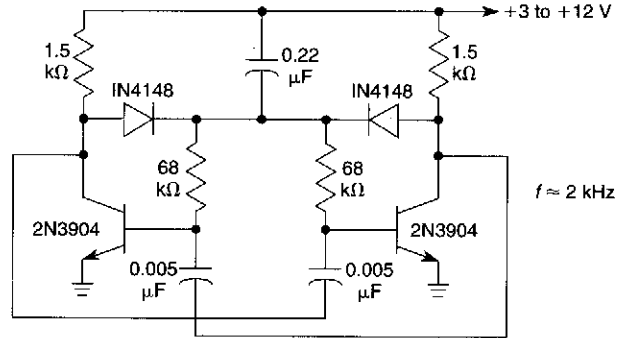

WILLIAM SHEETS

Fig. 58-1

This circuit will start with a slowly rising supply voltage waveform.

BISTABLE MULTIVIBRATOR

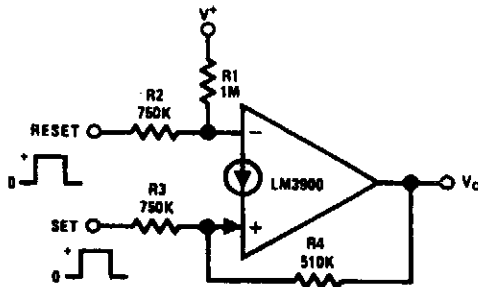

Positive feedback is provided by resistor R4, which causes the latching. A positive pulse at the "set" input causes the output to go high and a "reset" positive pulse will return the output to essentially 0 Vdc.

NATIONAL SEMICONDUCTOR

Fig. 58-2

ASTABLE

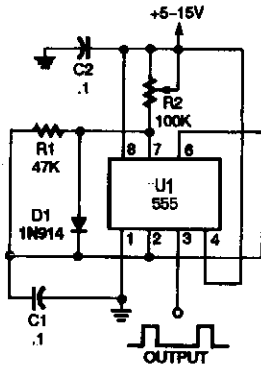

At the instant that power is applied to the 555 astable, timing capacitor C1 is initially discharged, causing the output of the chip output at pin 3 to be high. Once C1 has charged to about $\frac{2}{3}$ of the supply voltage, its output goes low, and the discharge transistor turns on, draining the charge on C1.

POPULAR ELECTRONICS

Fig. 58-3

ASTABLE WITH VARIABLE PULSE WIDTH

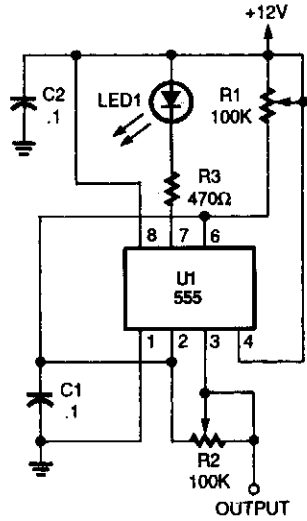

POPULAR ELECTRONICS

Fig. 58-4

This produces a positive variable width pulse and has a symmetry control. R1 and R2 control the pulse width and symmetry.

ONE-SHOT MULTIVIBRATOR

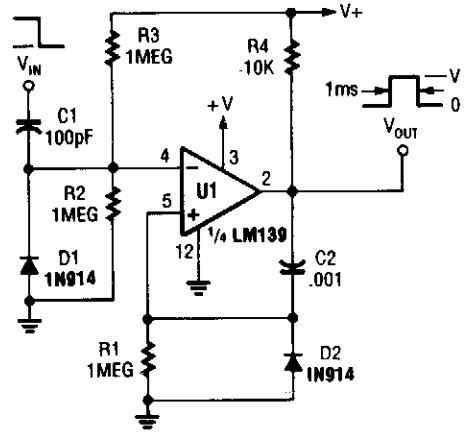

POPULAR ELECTRONICS

Fig. 58-5

An LM139 section can be used as a one shot.

BASIC 555 ASTABLE MULTIVIBRATOR

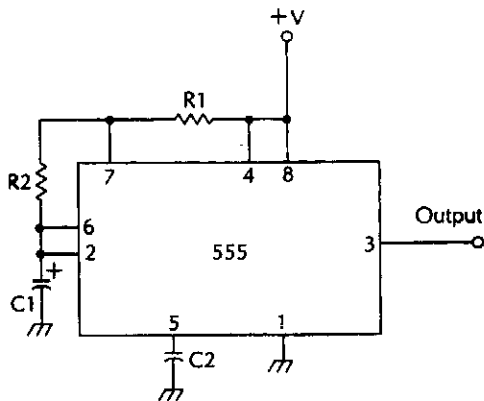

McGRAW-HILL

Fig. 58-6

$$F = 1.44$$

$$(R_1 + 2R_2) C_1$$

ASTABLE MULTIVIBRATOR

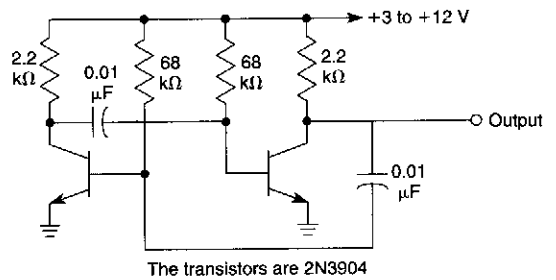

The transistors are 2N3904

WILLIAM SHEETS

Fig. 58-7

59

Noise Circuits

The sources of the following circuits are contained in the Sources section, which begins on page 707. The figure number in the box of each circuit correlates to the entry in the Sources section.

Noise Generator
Dolby Noise-Reduction Circuit
Audio Noise-Based Voting Circuit
Adjustable Noise Clipper
Simple Noise Limiter

NOISE GENERATOR

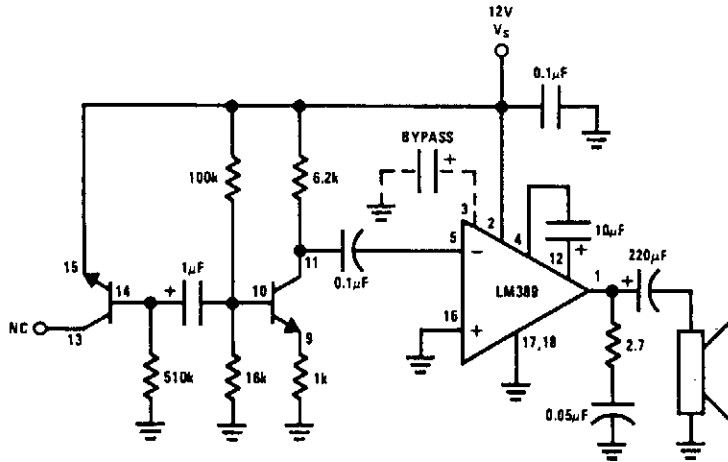

NATIONAL SEMICONDUCTOR

Fig. 59-1

This noise generator uses a Zener diode. The transistors are part of the LM389.

DOLBY NOISE-REDUCTION CIRCUIT

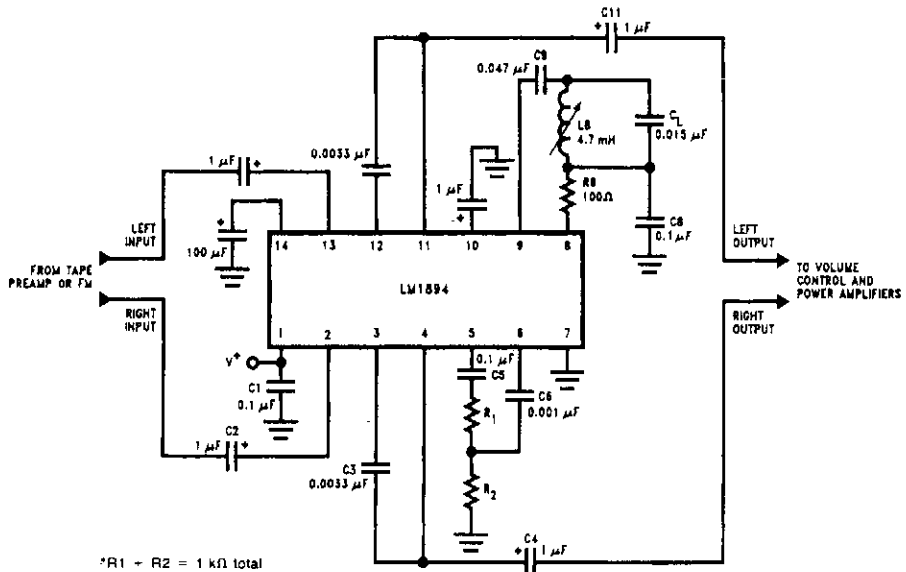

NATIONAL SEMICONDUCTOR

Fig. 59-2

AUDIO NOISE-BASED VOTING CIRCUIT

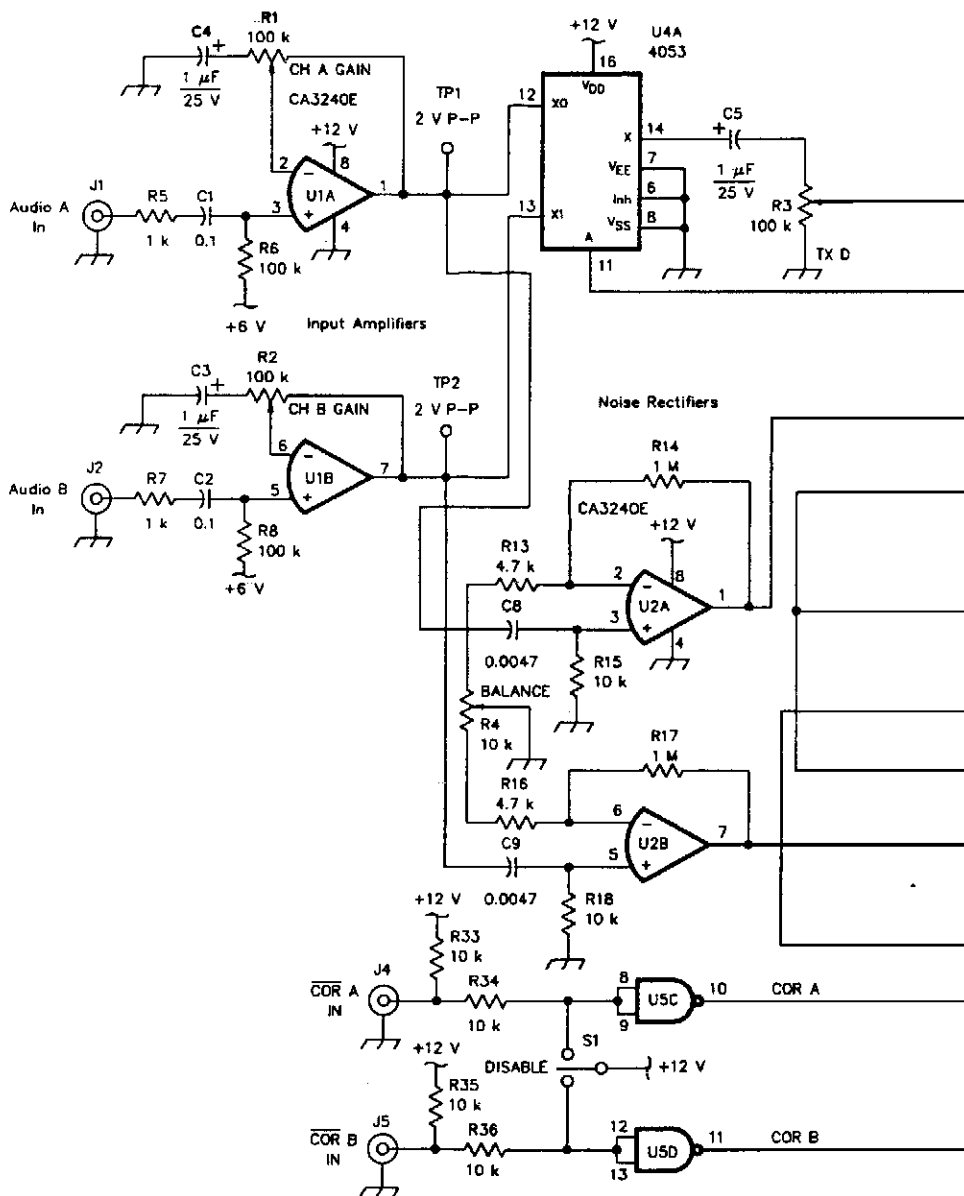

QST

The purpose of this circuit is the selection of the output of two receivers, tuned to the same channel, that has the better signal to noise ratio. This circuit compares the two noise leads from the receivers and selects the one with the lower audio noise level.

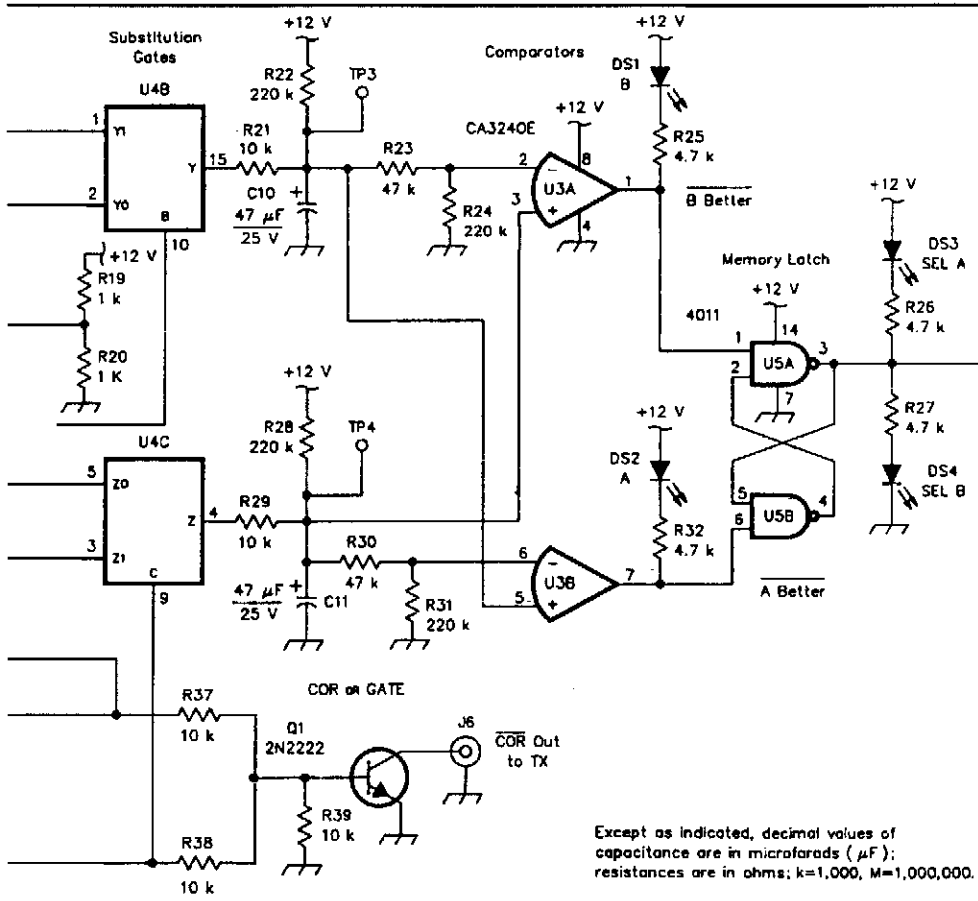
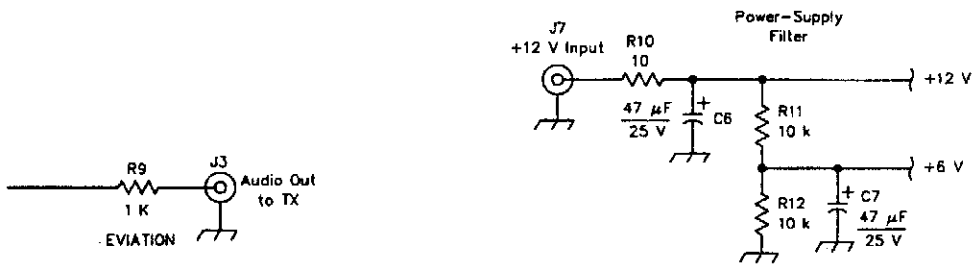

Except as indicated, decimal values of capacitance are in microfarads (μF); resistances are in ohms; k=1,000, M=1,000,000.

IC pins not shown are unused.

Fig. 59-3

ADJUSTABLE NOISE CLIPPER

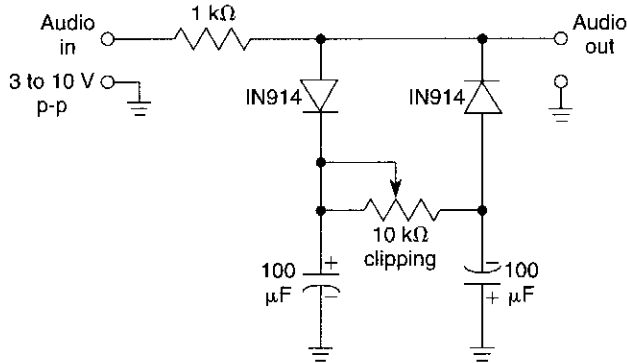

WILLIAM SHEETS

Fig. 59-4

This circuit uses two diodes and is a peak-to-peak limiter. The capacitors charge up to a dc level determined by the peak-to-peak audio signal and the clipping control. A positive or negative peak or spike is clipped if it exceeds this level plus the diode drops. The circuit should be operated at several volts level for best results.

SIMPLE NOISE LIMITER

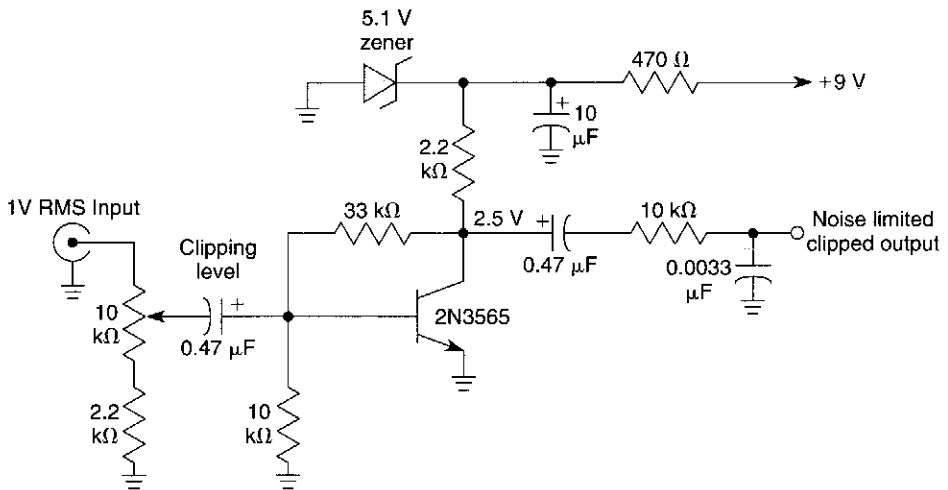

WILLIAM SHEETS

Fig. 59-5

This circuit uses a symmetrical limiter obtained by biasing a transistor to a Q point that is half of the supply voltage and driving it into saturation and cutoff. An input of 1 to 2 V RMS is sufficient. This output will be approximately 4 V p-p into a high-impedance load.

60

Operational Amplifier Circuits

The sources of the following circuits are contained in the Sources section, which begins on page 707. The figure number in the box of each circuit correlates to the entry in the Sources section.

- Basic Op-Amp Circuits
- Op Amps with Long RC Time Constants
- Op-Amp Offset Null
- Basic Op-Amp Audio Amplifier
- Input Guarding for HI-Z Op Amps
- Enhanced Op-Amp Balanced Amplifier
- Paralleled Power Op Amps
- Single-Supply Op-Amp Applications
- Current Regulator Op Amp
- Op-Amp Resistance-Multiplication Circuit
- Pseudoground

BASIC OP-AMP CIRCUITS

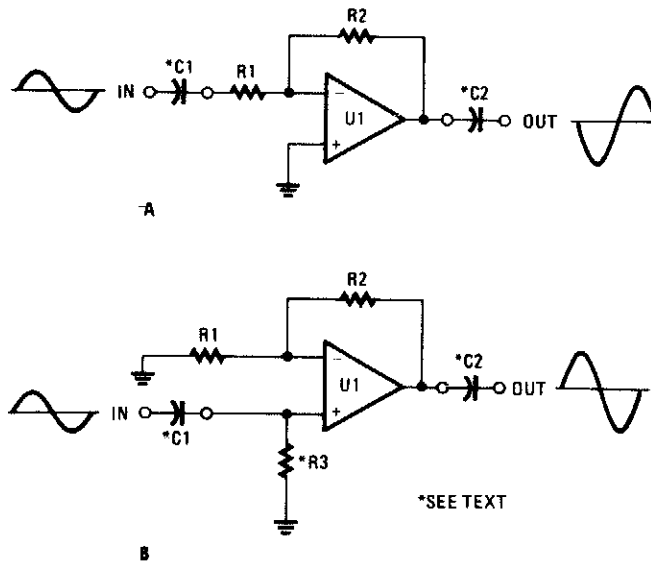

RADIO-ELECTRONICS

Fig. 60-1

The two simplest op-amp configurations are the inverting (A) and the noninverting (B). Resistor R3 is needed only if C1 is used in the noninverting circuit.

OP AMPS WITH LONG RC TIME CONSTANTS

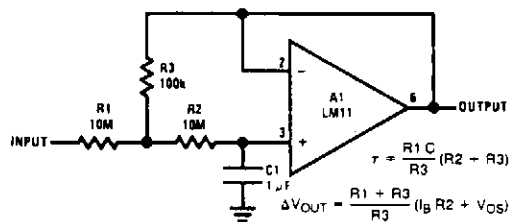

NATIONAL SEMICONDUCTOR

Fig. 60-2

This circuit multiplies RC time constant to 1000 seconds and provides low output impedance. Cost is lowered because of reduced resistor and capacitor values.

OP-AMP OFFSET NULL

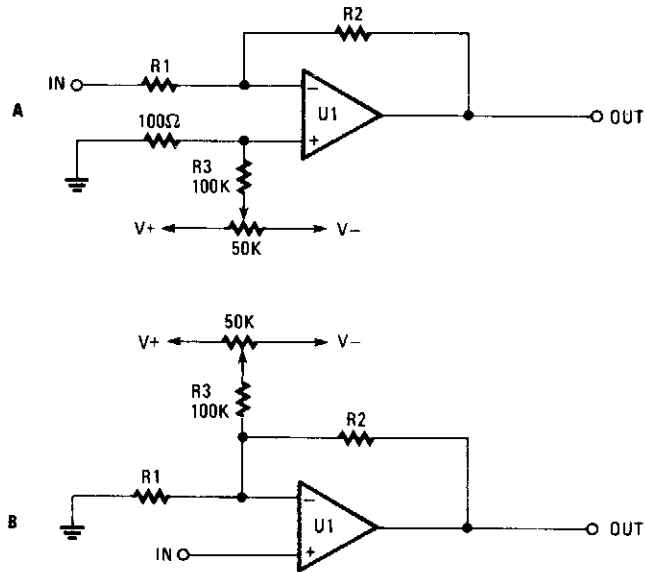

RADIO-ELECTRONICS

Fig. 60-3

Offset problems can occur in the best of circuits (and often do) without regard to whether the circuit is inverting (A), or noninverting (B). Offset-nulling potentiometers are useful in correcting the output to zero, but their effectiveness will vary under different conditions.

BASIC OP-AMP AUDIO AMPLIFIER

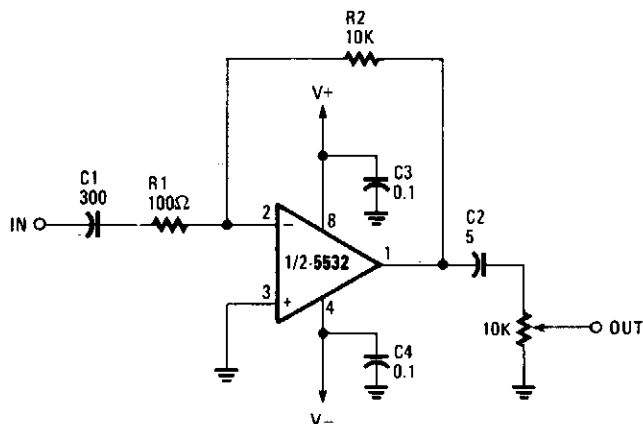

RADIO-ELECTRONICS

Fig. 60-4

Any general-purpose op amp can be used in this application.

INPUT GUARDING FOR HI-Z OP AMPS

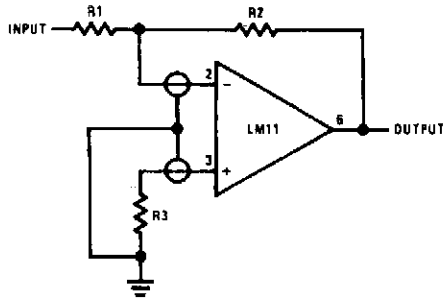

a. Inverting amplifier

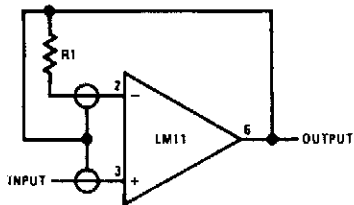

b. follower

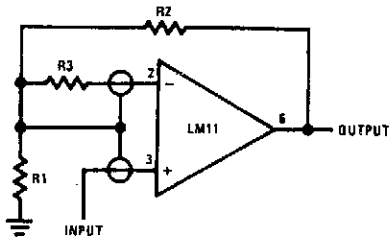

c. non-inverting amplifier

Input guarding for various op amp connections. The guard should be connected to a point at the same potential as the inputs with a low enough impedance to absorb board leakage without introducing excessive offset.

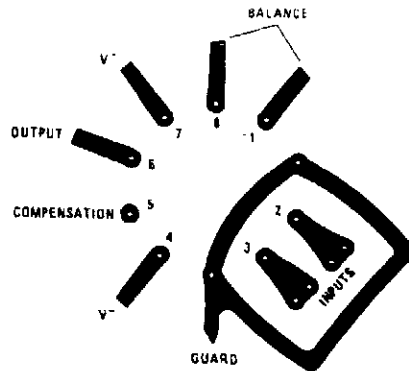

Bottom view

Input guarding can drastically reduce surface leakage. Layout for metal can is shown here. Guarding both sides of board is required. Bulk leakage reduction is less and depends on guard ring width.

ENHANCED OP-AMP BALANCED AMPLIFIER

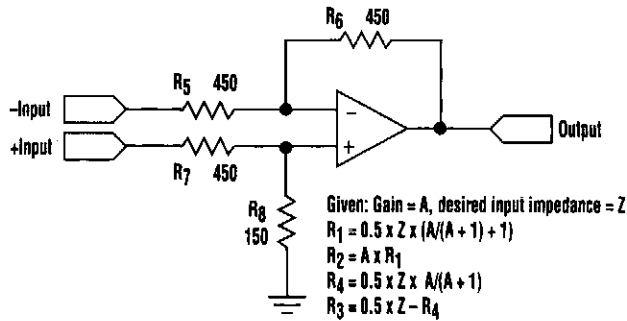
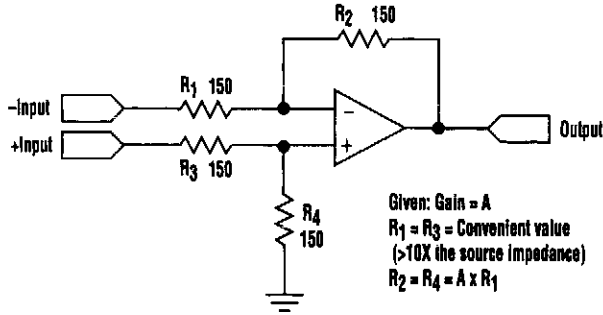

ELECTRONIC DESIGN

Fig. 60-6

The classic single op-amp balanced circuit works well in low-source-impedance configurations, but tends to struggle in higher-source-impedance applications because of the varying input impedance of the inputs referred to ground.

A modified version of the classic op-amp configuration of the figure uses a different set of formulas to determine the resistor values. It equalizes the impedance of both inputs by considering the op amp's active participation.

PARALLELED-POWER OP AMPS

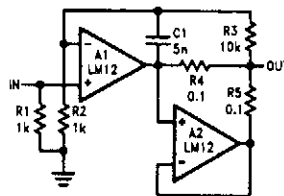

NATIONAL SEMICONDUCTOR

Fig. 60-7

Two power op amps can be paralleled using this master/slave arrangement, but high-frequency performance suffers.

SINGLE-SUPPLY OP-AMP APPLICATIONS

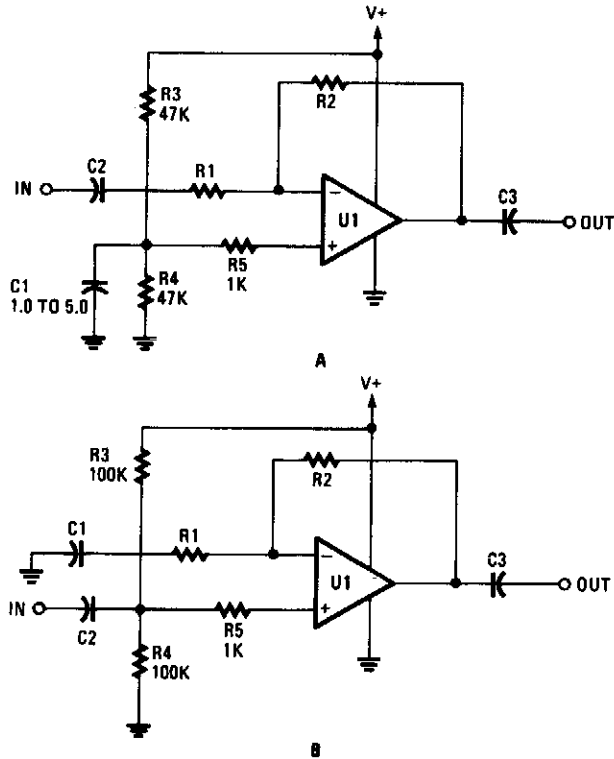

RADIO-ELECTRONICS

Fig. 60-8

An op amp that normally needs two supplies can be used when only a single supply is needed. The value of V_+ should be twice the minimum allowable values of the positive and negative voltages normally needed. For example, a 12-V single-supply application would require an op amp capable of ± 6 -V operation.

CURRENT REGULATOR OP AMP

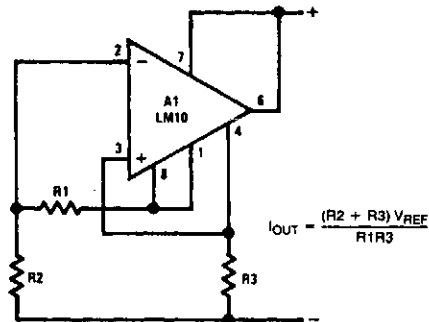

NATIONAL SEMICONDUCTOR

Fig. 60-9

OP-AMP RESISTANCE MULTIPLICATION CIRCUIT

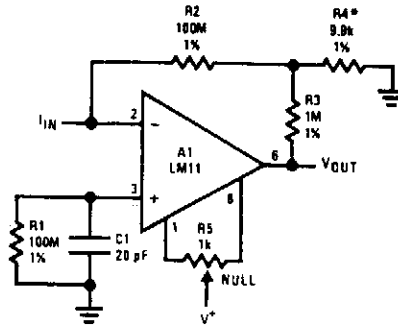

NATIONAL SEMICONDUCTOR

Fig. 60-10

Equivalent feedback resistance is $10\text{ G}\Omega$, but only standard resistors are used. Even though the offset voltage is multiplied by 100, output offset is actually reduced because error is dependent on offset current, rather than bias current. Voltage on summing junction is less than 5 mV.

PSEUDOGROUND

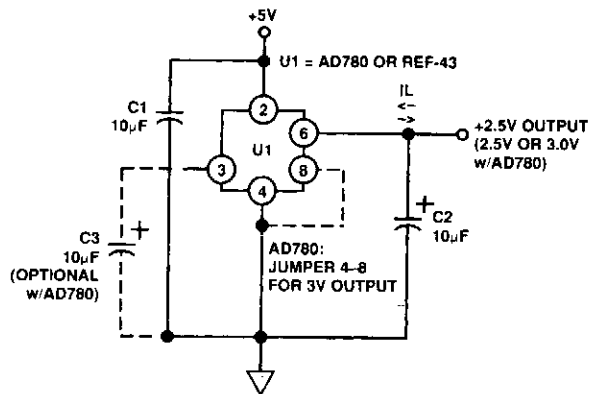

ANALOG DEVICES

Fig. 60-11

For op-amp circuits, a "pseudo ground" is often needed; a voltage reference IC can be used. The Analog Devices AD780 is used here for this application. This can sink or source current.

61

Oscillators (Audio)

The sources of the following circuits are contained in the Sources section, which begins on page 707. The figure number in the box of each circuit correlates to the entry in the Sources section.

Easily Tuned Sine-Wave Oscillator
Quad Tone Oscillator
One-Transistor Phase-Shift Oscillator
Basic LM3909 Audio Oscillator
Low-Distortion Sine-Wave Oscillator
Low-Frequency Astable
TTL-Based Audio Oscillator
Variable Duty Cycle from Astable
Simple Variable-Frequency Oscillator
Wien-Bridge Oscillator I
Wien-Bridge Oscillator II
Logic-Gate Sine-Wave Oscillator

EASILY TUNED SINE-WAVE OSCILLATOR

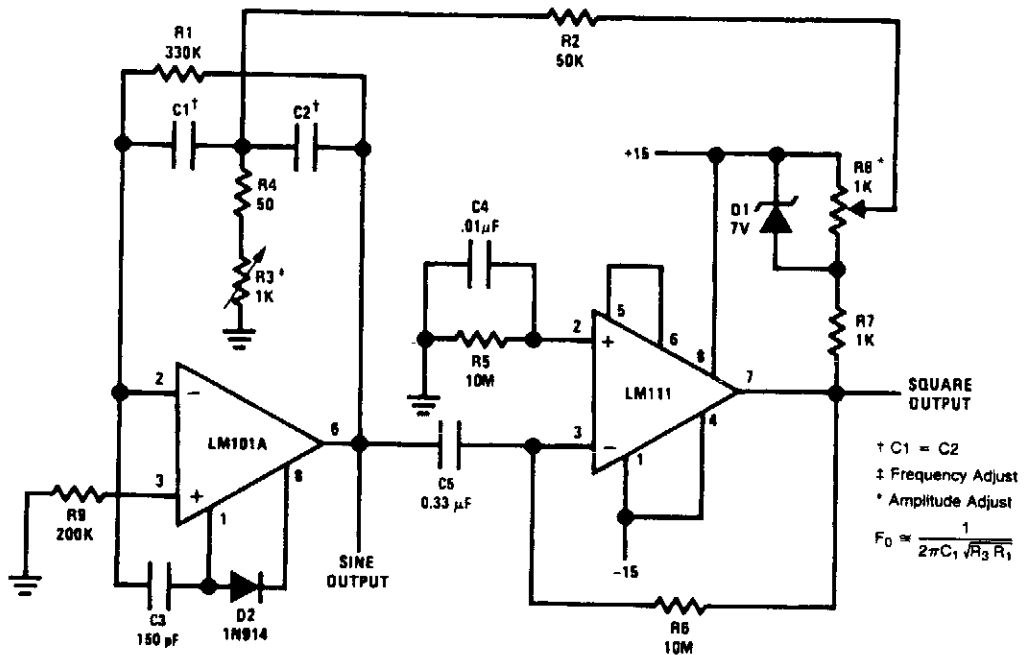

TABLE I

C ₁ , C ₂	Min Frequency	Max Frequency
0.47 µF	18 Hz	80 Hz
0.1 µF	80 Hz	380 Hz
.022 µF	380 Hz	1.7 kHz
.0047 µF	1.7 kHz	8 kHz
.002 µF	4.4 kHz	20 kHz

NATIONAL SEMICONDUCTOR

Fig. 61-1

The circuit will provide both a sine- and square-wave output for frequencies from below 20 Hz to above 20 kHz. The frequency of oscillation is easily tuned by varying a single resistor. This is a considerable advantage over Wien bridge circuits, where two elements must be tuned simultaneously to change frequency. Also, the output amplitude is relatively stable when the frequency is changed.

An operational amplifier is used as a tuned circuit, driven by square wave from a voltage comparator. Frequency is controlled by R1, R2, C1, C2, and R3, with R3 used for tuning. Tuning the filter does not affect its gain or bandwidth, so the output amplitude does not change with frequency. A comparator is fed with the sine-wave output to obtain a square wave. The square wave is then fed back to the input of the tuned circuit to cause oscillation. Zener diode, D1, stabilizes the amplitude of the square wave fed back to the filter input. Starting is ensured by R6 and C5, which provide dc negative-feedback around the comparator. This keeps the comparator in the active region.

QUAD TONE OSCILLATOR

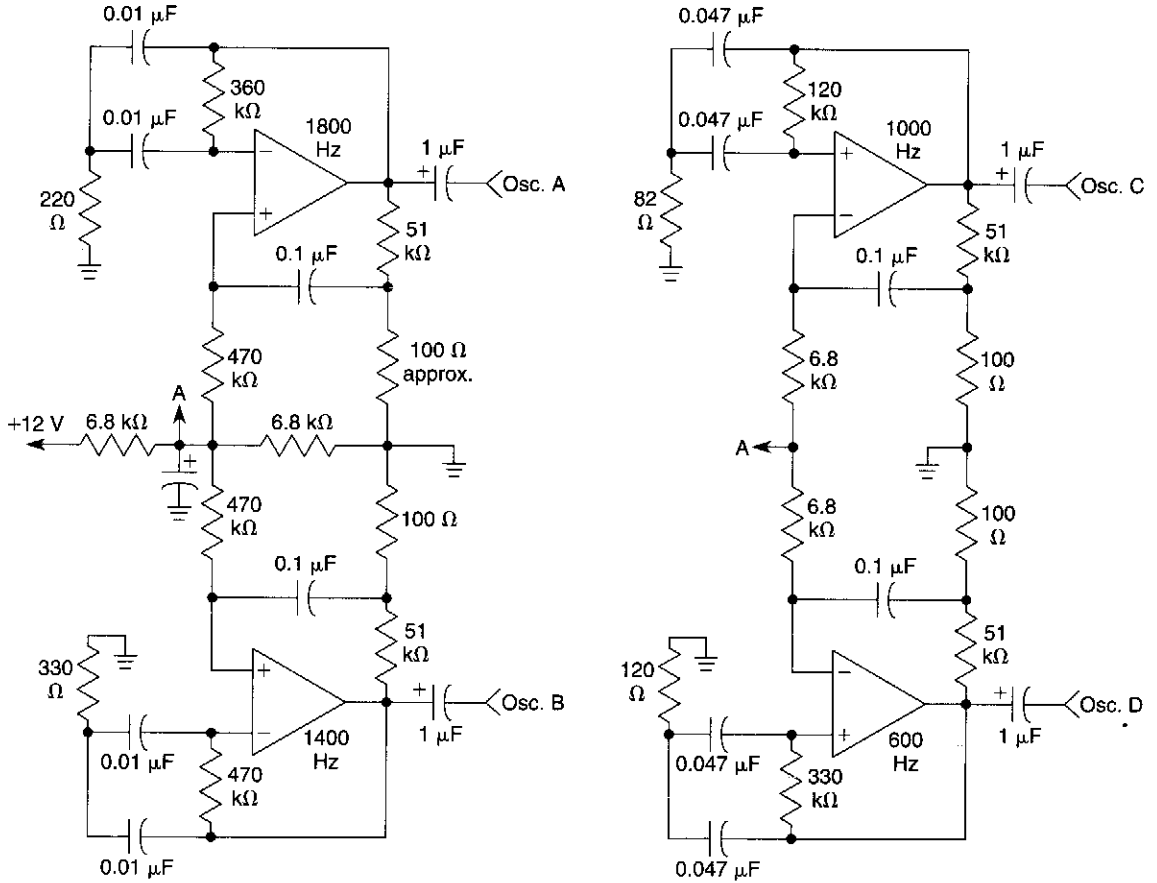

WILLIAM SHEETS

Fig. 61-2

A quad op amp (TL084, etc.) can be used to produce four audio tone generators for use in a test setup. The circuit uses a 12-V supply.

ONE-TRANSISTOR PHASE-SHIFT OSCILLATOR

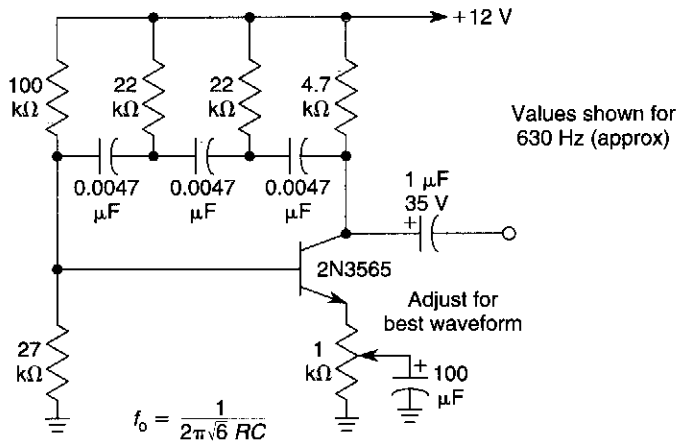

WILLIAM SHEETS

Fig. 61-3

A single transistor is used as an active element in an RC phase shift oscillator.

BASIC LM3909 AUDIO OSCILLATOR

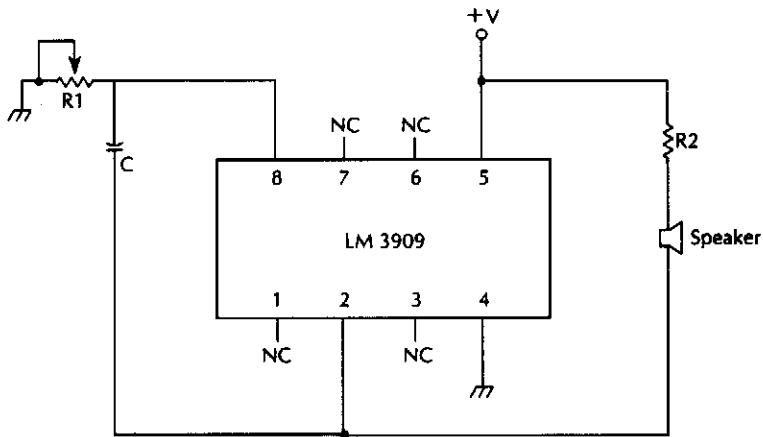

McGRAW-HILL

Fig. 61-4

The LM3909's oscillator frequency can be fine-tuned by adding a resistor to a basic circuit.

LOW-DISTORTION SINE-WAVE OSCILLATOR

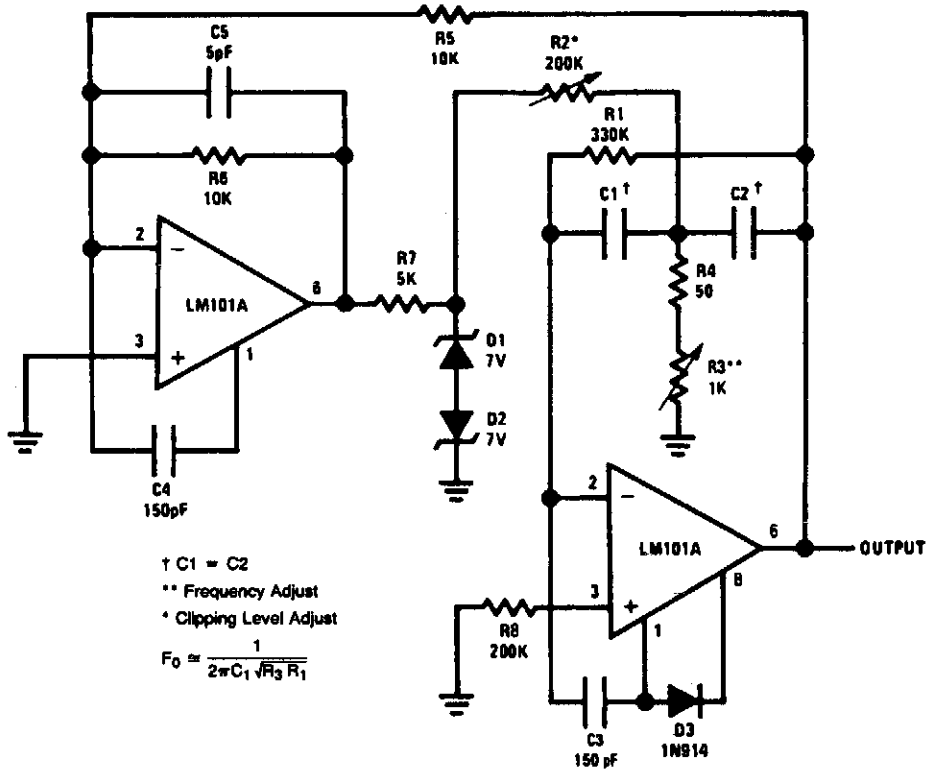

NATIONAL SEMICONDUCTOR

Fig. 61-5

C1, C2	Min. Frequency	Max. Frequency
0.47 μF	18 Hz	80 Hz
0.1 μF	80 Hz	380 Hz
0.022 μF	380 Hz	1.7 kHz
0.0047 μF	1.7 kHz	8 kHz
0.002 μF	4.4 kHz	20 kHz

LOW-FREQUENCY ASTABLE

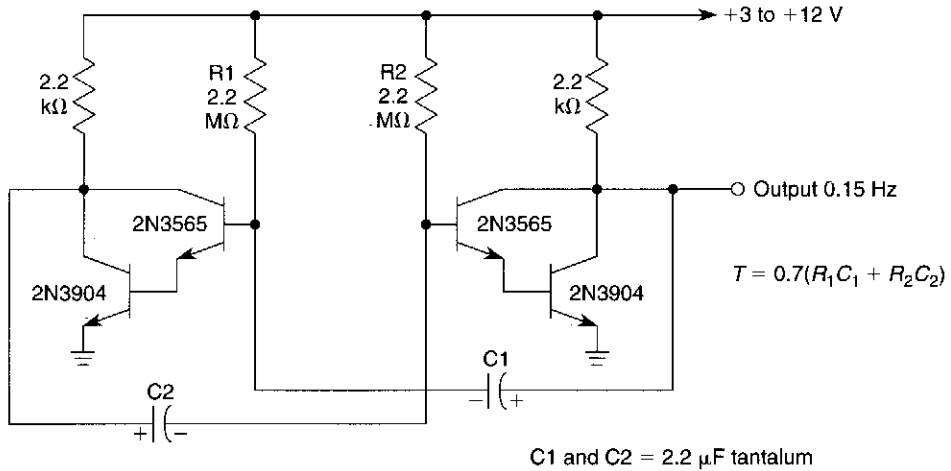

WILLIAM SHEETS

Fig. 61-6

By using a high-gain low-current transistor, such as the 2N3565, a pair of Darlington-connected transistors (2N3565 and 2N3904) can be used in a high-impedance configuration.

TTL-BASED AUDIO OSCILLATOR

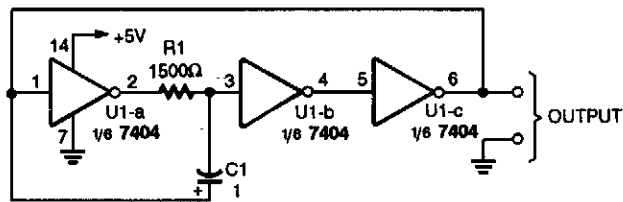

POPULAR ELECTRONICS

Fig. 61-7

Half a 7404 will produce a tone around 1000 Hz with this circuit.

VARIABLE DUTY CYCLE FROM ASTABLE

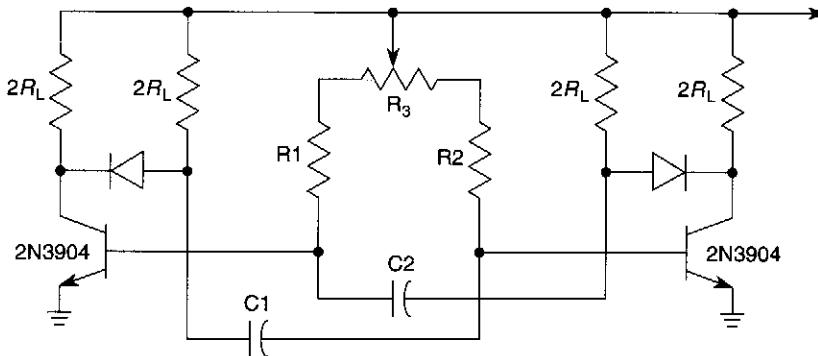

$$R_L = 2.2 \text{ k}\Omega$$

$$R_3 = 100 \text{ k}\Omega$$

$$R_1 = 18 \text{ k}\Omega = R_2$$

$$C_1 = 0.01 \text{ }\mu\text{F} = C_2$$

WILLIAM SHEETS

Fig. 61-8

If $R_1 = R_2 = R_3$ and $C_1 = C_2 = C_3$

If potentiometer R_3 is set at $N\%$ of rotation, then

$$T_{\text{TOTAL}} \approx 0.7 [(R + NR_3)C + [R + (1 - N)R_3]C]$$

$T_{\text{TOTAL}} \approx 1.4 (R + R_3)C$ and the duty cycle can be varied without changing frequency.

SIMPLE VARIABLE-FREQUENCY OSCILLATOR

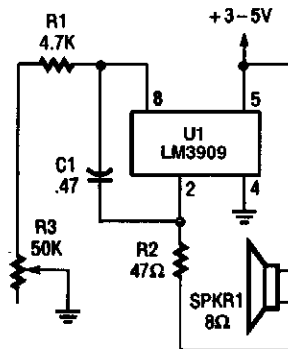

POPULAR ELECTRONICS

Fig. 61-9

In this variable audio frequency oscillator, the output of U1 at pin 2 is used to drive an 8- Ω speaker through R2 (which functions as a current-limiter).

WIEN-BRIDGE OSCILLATOR I

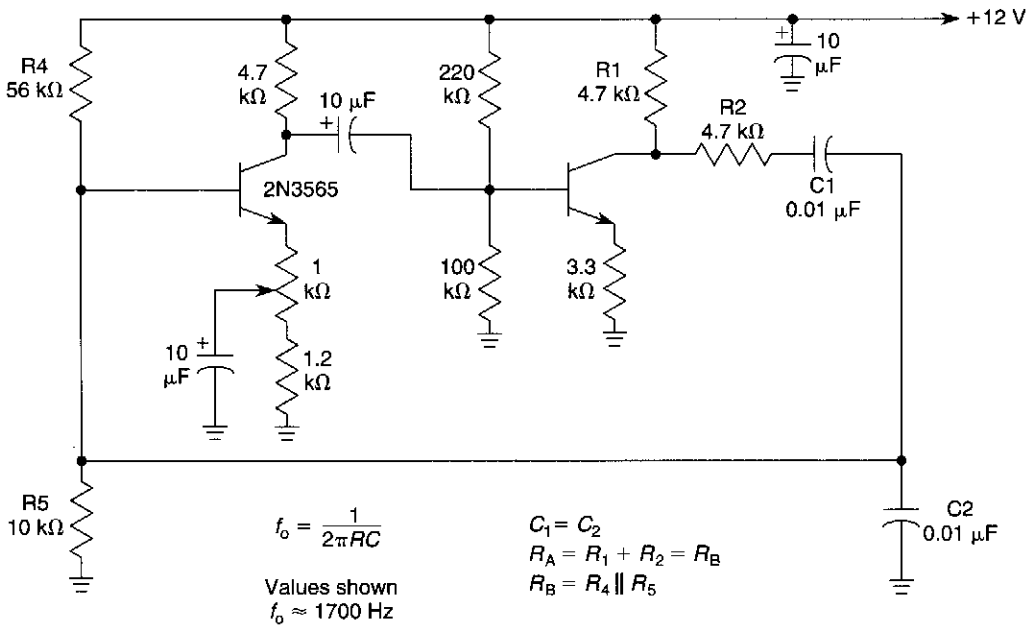

WILLIAM SHEETS

Fig. 61-10

WIEN-BRIDGE OSCILLATOR II

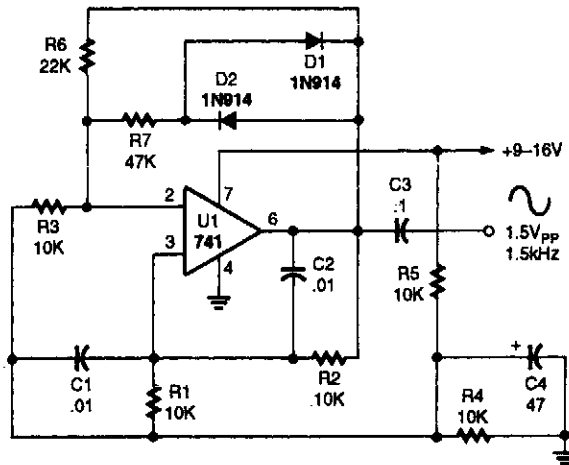

POPULAR ELECTRONICS

Fig. 61-11

The operating frequency of this Wien-bridge oscillator is determined by C1, C2, R1, and R2. It can easily be modified to act as a tunable oscillator by substituting a dual-gang linear potentiometer for R1 and R2.

LOGIC-GATE SINE-WAVE OSCILLATOR

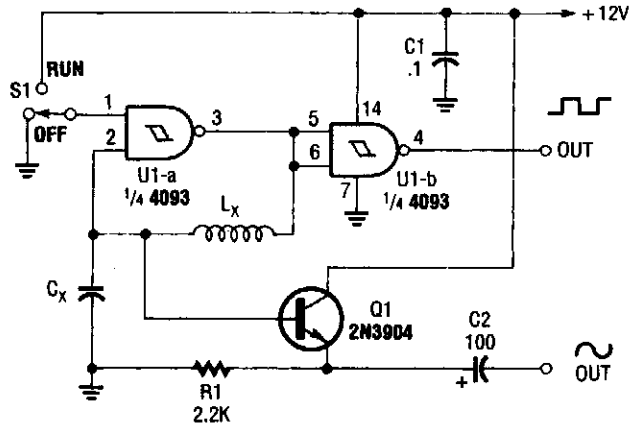

*SEE TEXT

C_x	L_x	f_{out}
.018	50mH	9kHz
.018	2mH	14kHz
.047	5mH	5.5kHz
1	1H	300Hz
1	10H	100Hz

An inductor and capacitor are used here as frequency-determining elements in an LC oscillator.

62

Oscillators (Miscellaneous)

The sources of the following circuits are contained in the Sources section, which begins on page 707. The figure number in the box of each circuit correlates to the entry in the Sources section.

- Variable-Frequency Astable I
- Astable Oscillator I
- Astable Oscillator II
- Variable-Frequency Astable II
- Quadrature-Wave Oscillator
- Stabilized Wien-Bridge Oscillator
- Digitally Controlled Square-Wave Oscillator
- 50% Duty-Cycle 555 Circuit
- Varied Rep Rate, Duty Cycle with 555
- DDS Digital VFO

VARIABLE-FREQUENCY ASTABLE I

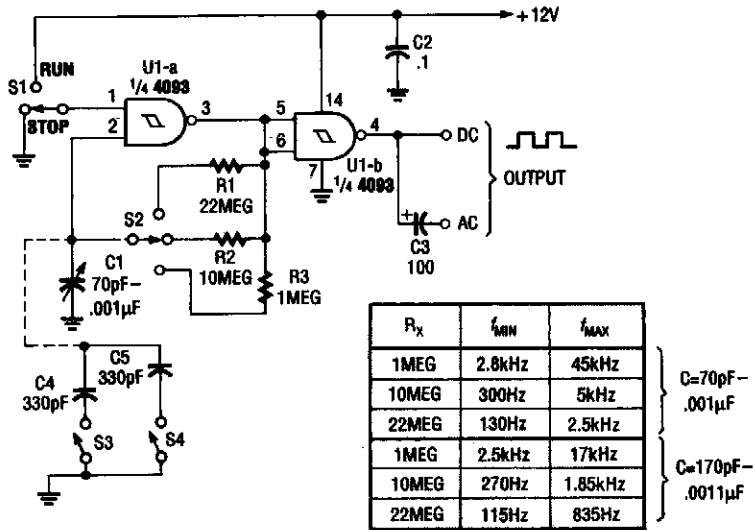

POPULAR ELECTRONICS

Fig. 62-1

This circuit is a variable-frequency oscillator using a trimmer capacitor or a three-gauge AM broadcast capacitor salvaged from an old AM radio. The three sections must be paralleled.

ASTABLE OSCILLATOR I

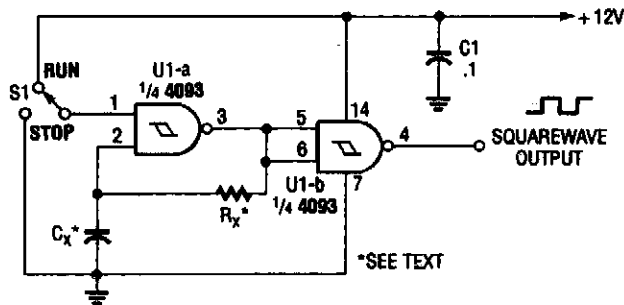

POPULAR ELECTRONICS

Fig. 62-2

In this circuit, two gates from the quad 4093 package are used to form a simple astable square-wave oscillator.

The values for R_x and C_x are approximately as follows:

C_x	R_x	f_o
0.001 μF	1 M Ω	3 kHz
0.1 μF	1 M Ω	30 Hz
1 μF	10 M Ω	0.03 Hz

These values can be scaled for other frequencies.

ASTABLE OSCILLATOR II

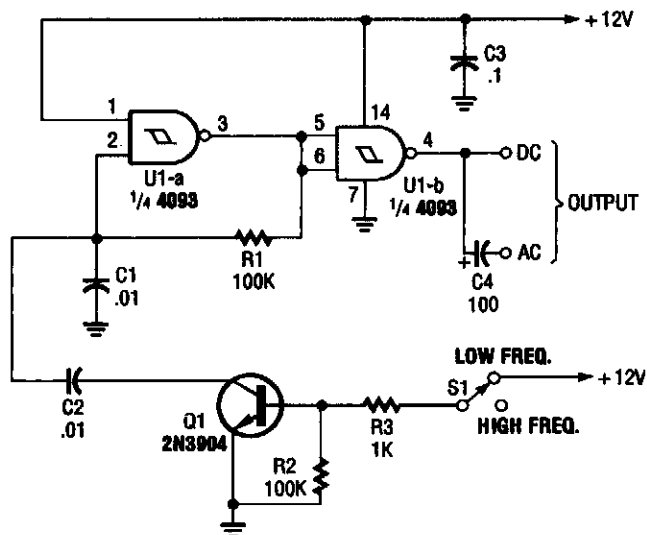

POPULAR ELECTRONICS

Fig. 62-3

By using transistor switch Q1/R2/R3, the frequency of an astable oscillator can be changed with a dc voltage or logic level.

VARIABLE-FREQUENCY ASTABLE II

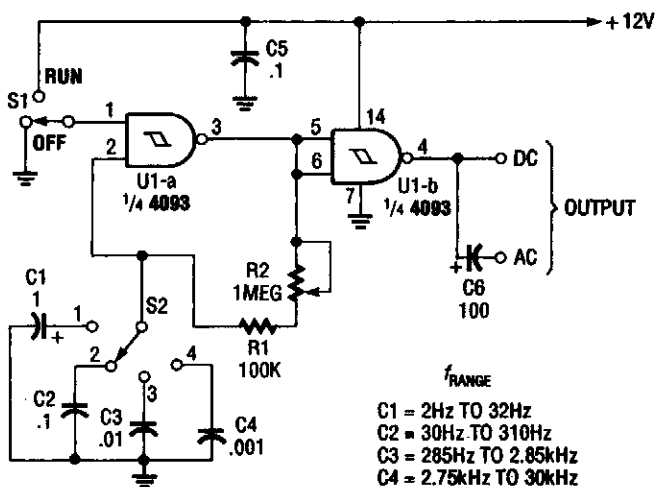

POPULAR ELECTRONICS

Fig. 62-4

This circuit uses a single potentiometer and switched capacitors to cover 2 Hz to 30 kHz.

QUADRATURE-WAVE OSCILLATOR

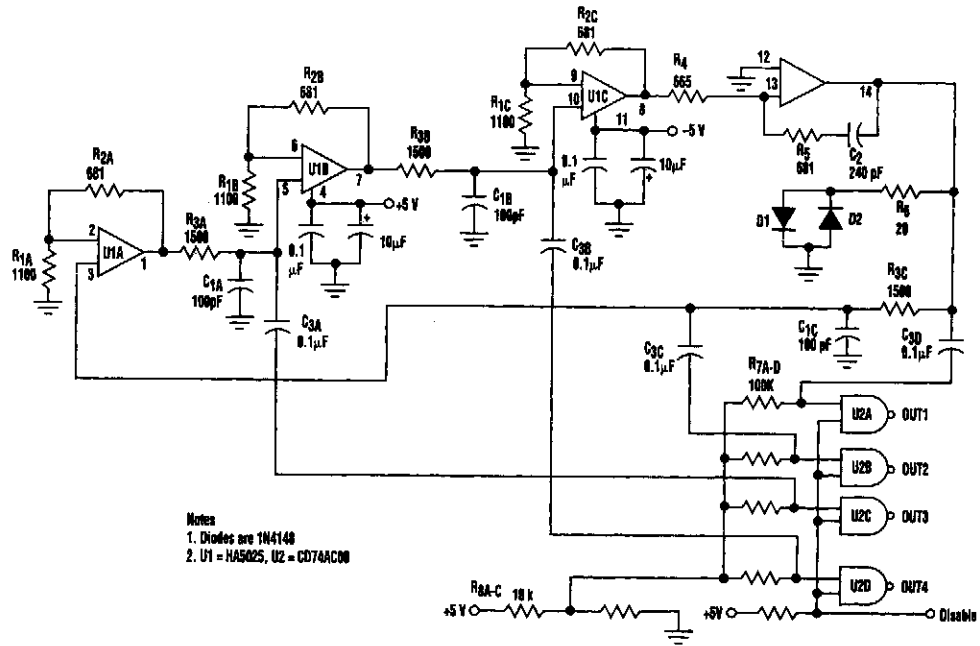

ELECTRONIC DESIGN

Fig. 62-5

By using a high-frequency quad current-feedback amplifier (the HA5025) as an RC oscillator, four quadrature sine waves can be generated. The HA5025's four separate amplifiers generate the sine waves, and the quad NAND gate, U2, is biased at its threshold, so it acts as a sine-wave to square-wave converter when the sine waves are ac coupled into its input.

STABILIZED WIEN-BRIDGE OSCILLATOR

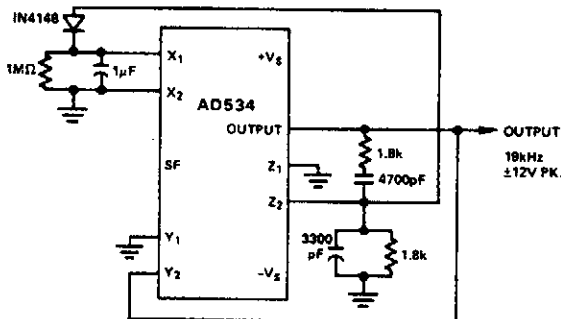

In this application, the AD534 is used as a variable-gain amplifier for the feedback signal from the output to the Y input, via the Wien bridge. The peak-rectifier and filter combination applies sufficient voltage to the X (denominator) input to maintain a stable oscillation-amplitude (with about 0.2% ripple). At startup, because X is small (divider mode), the gain is high, and the oscillation builds up rapidly. This is but one of several possible schemes, involving no external active elements. Its forte is simplicity, rather than high performance; nevertheless, the amplitude is not greatly affected by supply and temperature variations, about 0.003 dB per volt, and 0.005 dB per degree.

ANALOG DEVICES

Fig. 62-6

DIGITALLY CONTROLLED SQUARE-WAVE OSCILLATOR

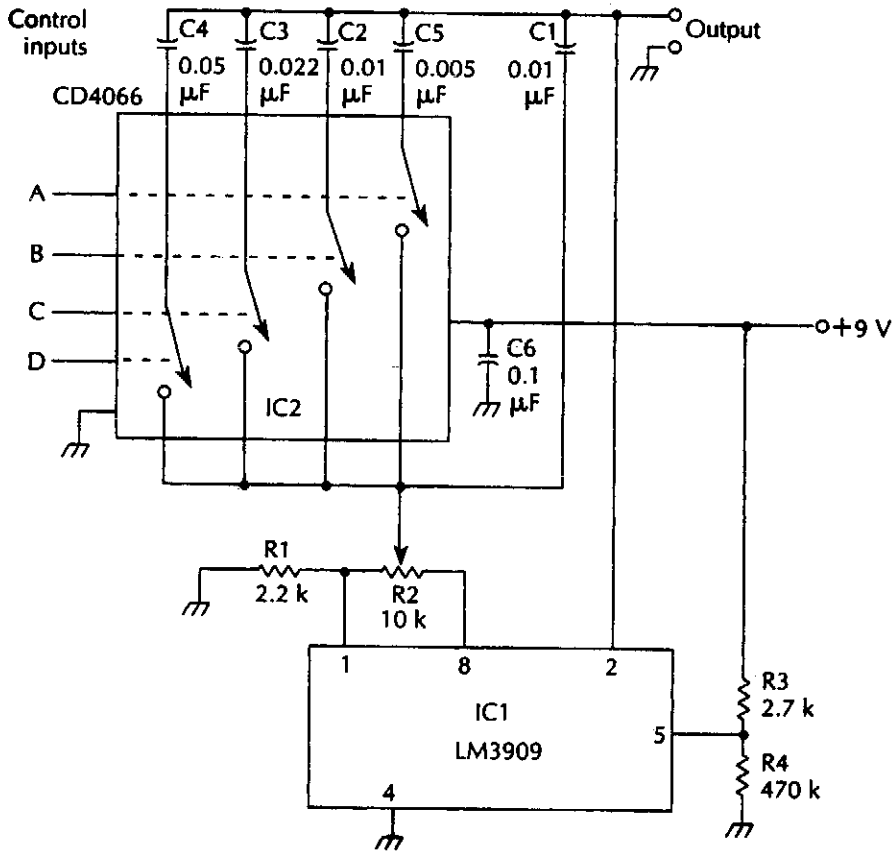

McGRAW-HILL

Fig. 62-7

IC1	LM3909 LED flasher/oscillator	C5, C6	0.1- μ F capacitor
IC2	CD4066 quad bilateral switch	R1	2.2-k Ω , 1/4-W 5% resistor
C1, C2	0.1- μ F capacitor	R2	10-k Ω potentiometer
C3	0.033- μ F capacitor	R3	2.7-k Ω , 1/4-W 5% resistor
C4	0.047- μ F capacitor	R4	470- Ω , 1/4-W 5% resistor

50% DUTY-CYCLE 555 CIRCUIT

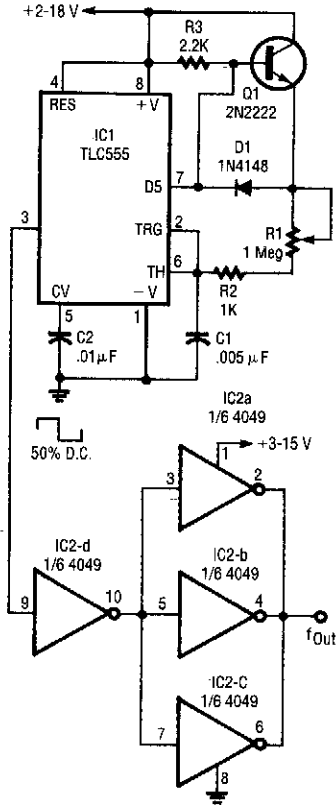

Using an external charge transistor and diode enables a 50% duty cycle and easy frequency control. When the 555's discharge transistor is cut off, the 2N2222 acts as an emitter follower. When the discharge transistor turns on, the 2N2222 turns off and C1 discharges through $(R_1 + R_2)$ at the same rate. The 1N4148 provides temperature compensation.

ELECTRONICS NOW

Fig. 62-8

VARIED REP RATE, DUTY CYCLE WITH 555

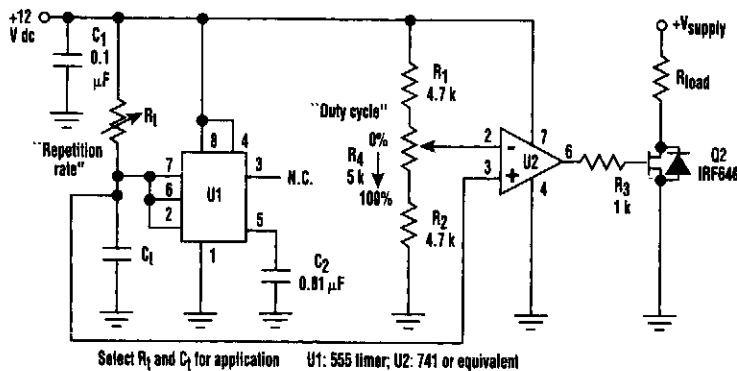

To independently vary rpm and dwell, or duty cycle, a 555 timer is used to produce a ramp waveform, which is compared to an adjustable reference.

ELECTRONIC DESIGN

Fig. 62-9

DDS DIGITAL VFO

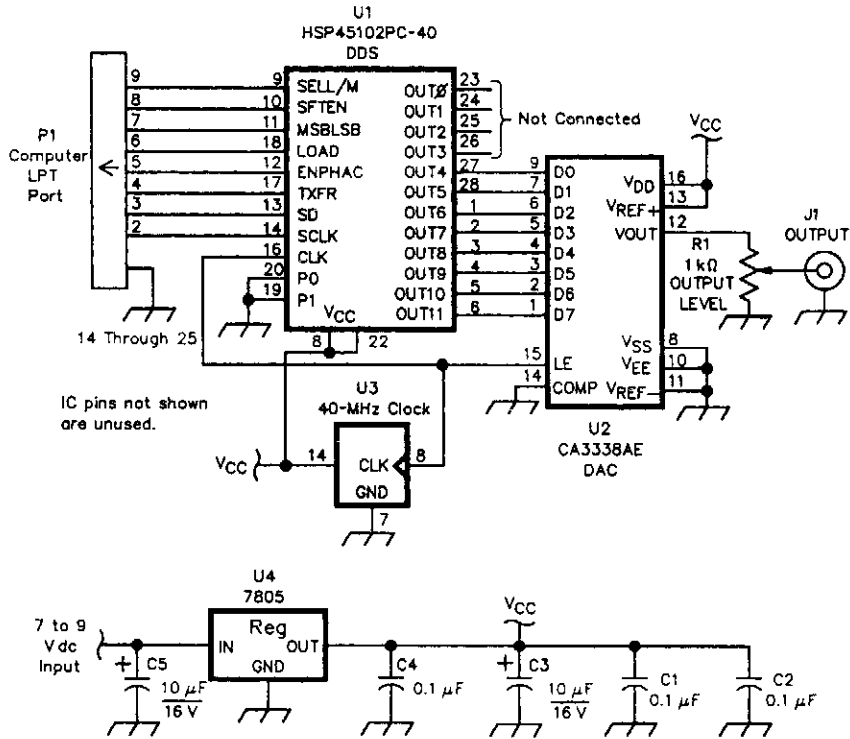

QST

Fig. 62-10

The DDS chip (U1) generates a data stream that is converted by D/A converter U2 into a sine wave. U1 is programmed via the input from P1, from the LPT port of an IBM PC. The system uses a 40-MHz TTL output clock module.

63

Oscillators (RF)

The sources of the following circuits are contained in the Sources section, which begins on page 707. The figure number in the box of each circuit correlates to the entry in the Sources section.

Frequency Modulated Oscillator
JFET Variable-Frequency Oscillator
AM Oscillator for Wireless Microphones
Reinartz Oscillator
Remote-Oscillator High-Frequency VFO
Beat-Frequency Oscillator for AM/SW Radios
Butler Oscillator Circuit
455-kHz Oscillator
Modified Hartley Oscillator
VLF LC Oscillator
Grounded-Base Tuned Collector Oscillator for
AM Broadcast Band

HF VFO Circuit
Darlington Transistor Oscillator
FM HF Oscillator With No Varactor
Tunable UHF Oscillator
“Universal” VFO
Oscillator Circuits
Colpitts Oscillator
Clapp Oscillator for 100 kHz
Tuned Collector Oscillator
Hartley Oscillator

FREQUENCY MODULATED OSCILLATOR

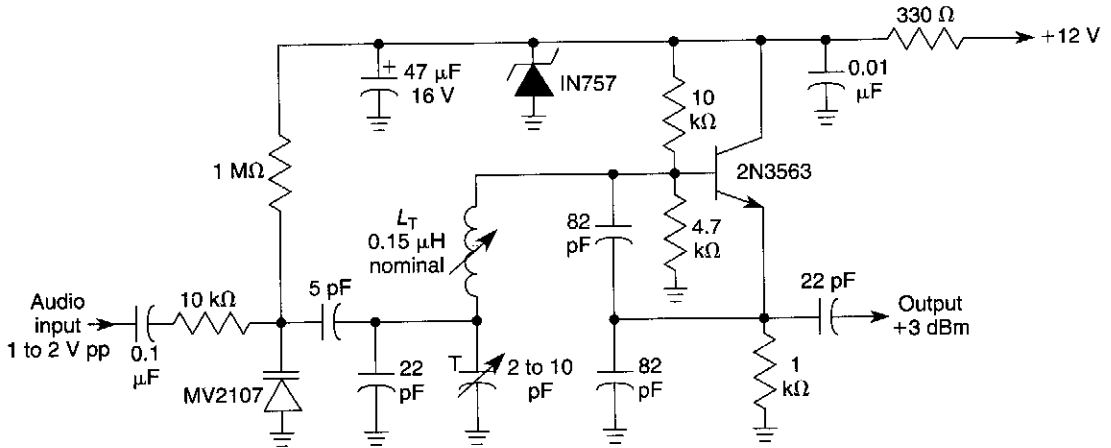

WILLIAM SHEETS

Fig. 63-1

This circuit can be used for FM wireless audio, microphone, and part-15 applications where a stable frequency modulated oscillator is needed. L_T can be varied to cover 75 to 150 MHz, as needed.

JFET VARIABLE-FREQUENCY OSCILLATOR

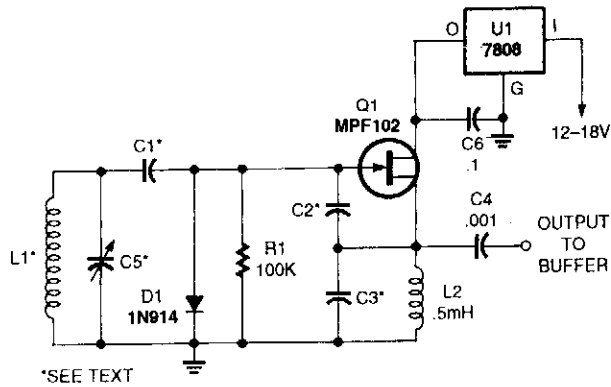

f_o MHz	L1 (TURNS)	C2 AND C3 (pF)	C1 (pF)	VARIABLE C5 (pF)
2-6	36	680	150	100
5-8	25	470	100	100
7-14	20	470	100	50

POPULAR ELECTRONICS

Fig. 63-2

This simple JFET-based variable-frequency oscillator can be used in receiver and transmitter circuits.

AM OSCILLATOR FOR WIRELESS MICROPHONES

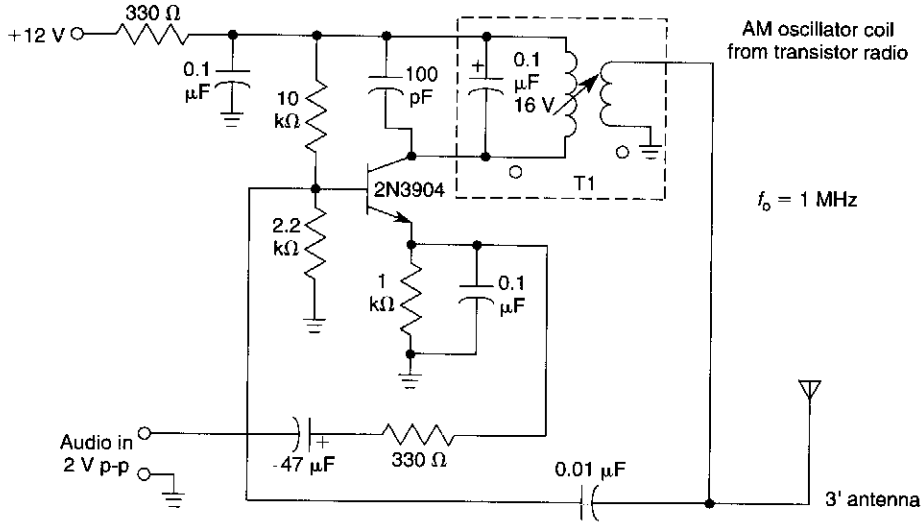

WILLIAM SHEETS

Fig. 63-3

This circuit will generate an AM-modulated signal in the AM broadcast band that can be picked up on a receiver. About 2 V of audio input will produce about 30% modulation of the oscillator signal. An old AM broadcast oscillator coil or other two-winding coil with about a 10:1 turn ratio and about 50 to 150 μH inductance can be used for T1.

REINARTZ OSCILLATOR

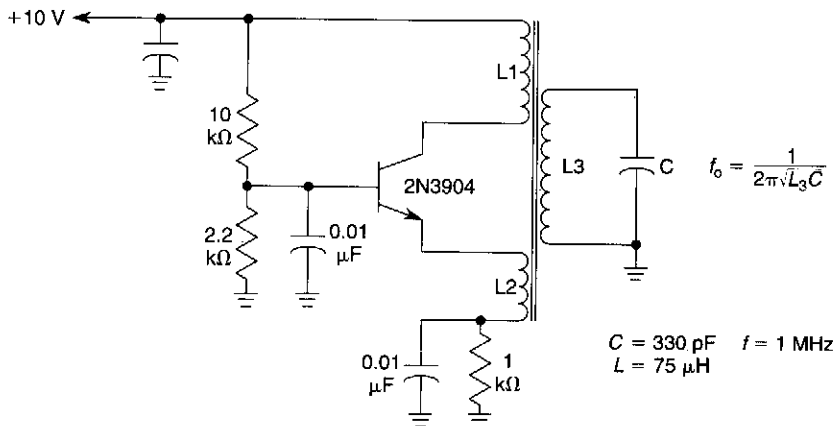

WILLIAM SHEETS

Fig. 63-4

This oscillator uses inductivity coupled emitter and collector windings to its main tank circuit. Take care so that L1 and L2 are not coupled to each other, otherwise this circuit is susceptible to parasitic oscillation at other frequencies. Typically, L1 has 5 to 10 times the number of turns that L2 has. L1, L2, L3 are wound on same coil form. This oscillator is more suited to lower frequencies, ≤ 10 MHz.

REMOTE-OSCILLATOR HIGH-FREQUENCY VFO

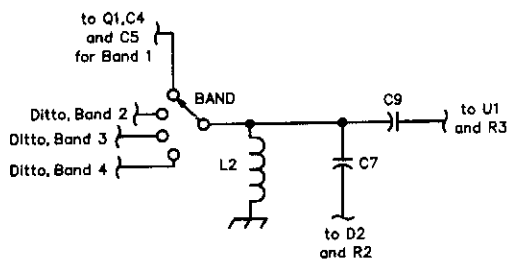
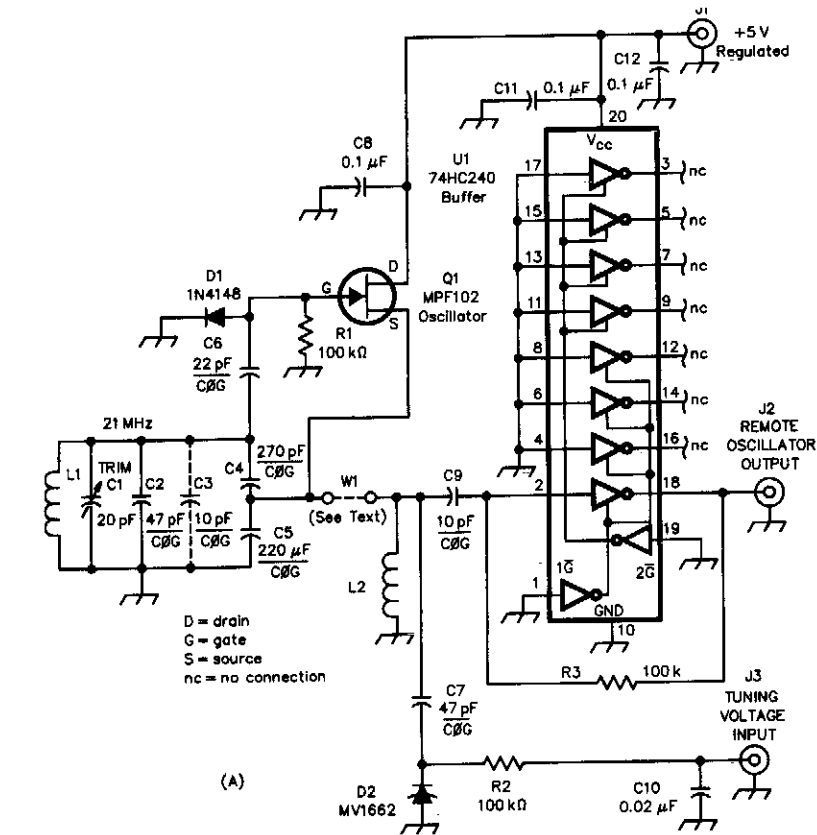

Band-Specific Oscillator Component Values

Band (m)	L1 (turns*)	Approximate Tuning Range† (kHz)
10	3	110
12	4	100
15	5	80
17	6	65
20	7	50
30	10	40

*Close-wound #20 enameled wire on a 3/8-inch plastic rod; see text.

†With an MV1662 diode used at D1, and C7 (Figure 2) equal to 47 pF. See text, Note 2 and the Figure 2 parts list.

QST

Fig. 63-5

A remote VFO is sometimes used to control a transmitter or receiver. The circuit shown uses an MPF102 FET and is controlled by a dc voltage at J3. The table shows values for L_1 for various bands from 30 to 10 meters. U1 serves as a buffer amplifier.

BEAT-FREQUENCY OSCILLATOR FOR AM/SW RADIOS

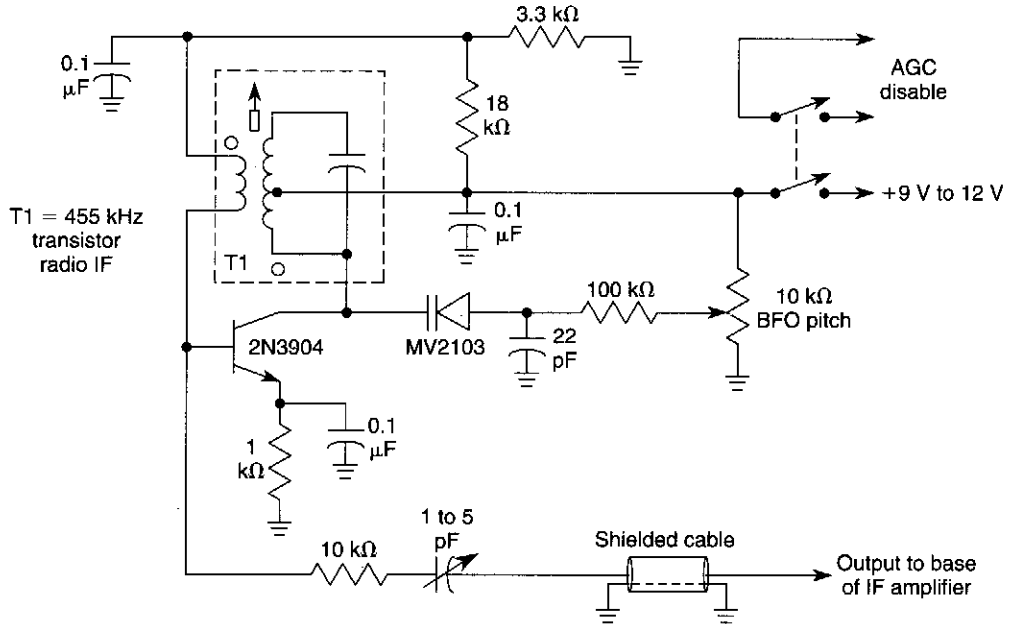

WILLIAM SHEETS

Fig. 63-6

This BFO can be added to inexpensive AM/SW receivers to enable reception of CW signals. Output couples to base of last IF stage. T1 is any 455-kHz IF transformer. The BFO switch should be a DPDT type (as needed), and the radio AGC circuit will probably have to be disabled for CW reception.

BUTLER OSCILLATOR CIRCUIT

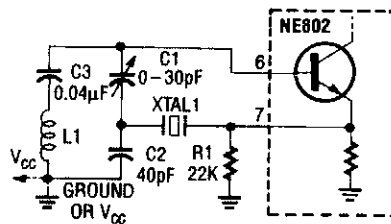

RADIO-ELECTRONICS

Fig. 63-7

This circuit uses an overtone crystal in a Butler oscillator. L1 is approximately 1300 μH, and the crystal frequency should be from 20 to 50 MHz.

455-kHz OSCILLATOR

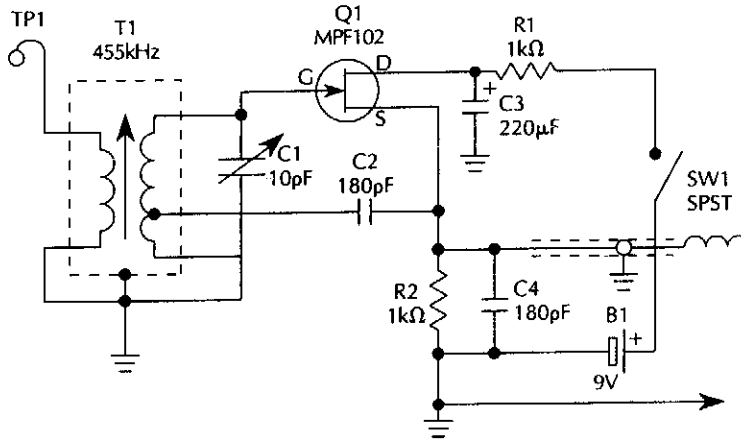

McGRAW-HILL

Fig. 63-8

The 455-kHz oscillator circuit uses a field-effect transistor (FET) for Q1. The output signal is taken from the source circuit of Q1. T1 is a 455-kHz IF transformer.

MODIFIED HARTLEY OSCILLATOR

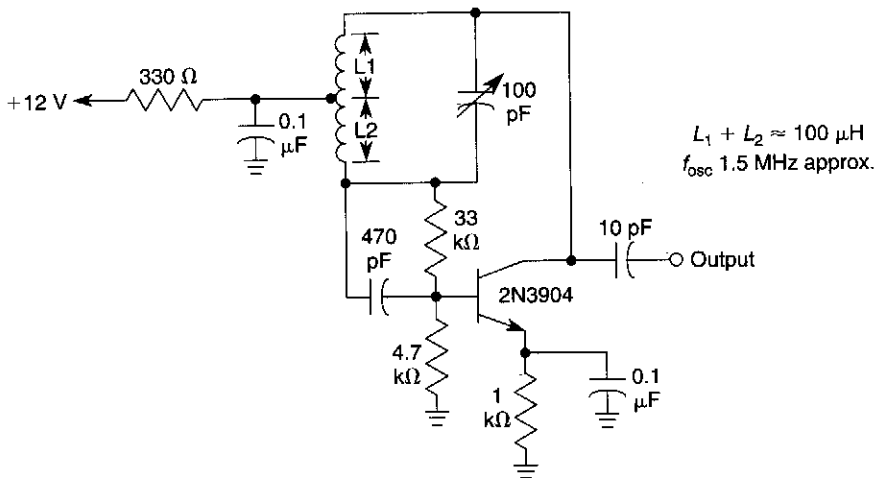

WILLIAM SHEETS

Fig. 63-9

This oscillator uses a tapped coil in the collector circuit, with the tap grounded for the signal. L1 and L2 are coupled inductively and typically have a 3:1 turn ratio, and generally are sections of one entire winding.

VLF LC OSCILLATOR

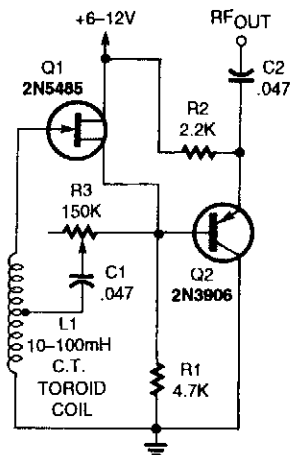

The VLF oscillator uses a large toroid coil as the frequency-determining component and a 2N5485 FET as the active device. R3 is used as a feedback control and also by running the circuit with slightly less feedback than needed for oscillation, can serve as a regenerative amplifier or detector.

POPULAR ELECTRONICS

Fig. 63-10

GROUNDLED-BASE TUNED COLLECTOR OSCILLATOR FOR AM BROADCAST BAND

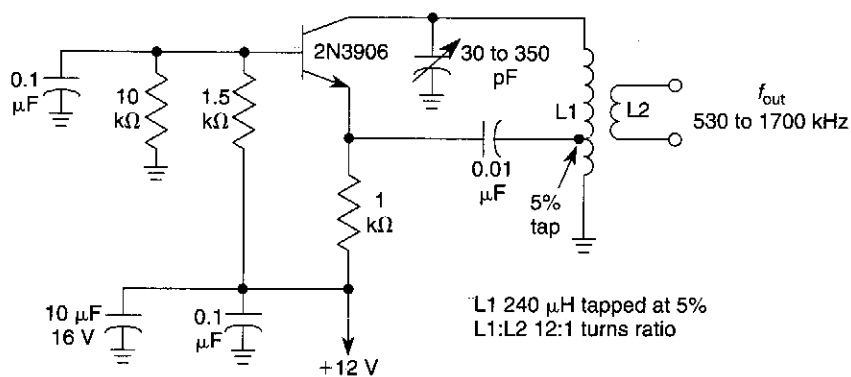

WILLIAM SHEETS

Fig. 63-11

HF VFO CIRCUIT

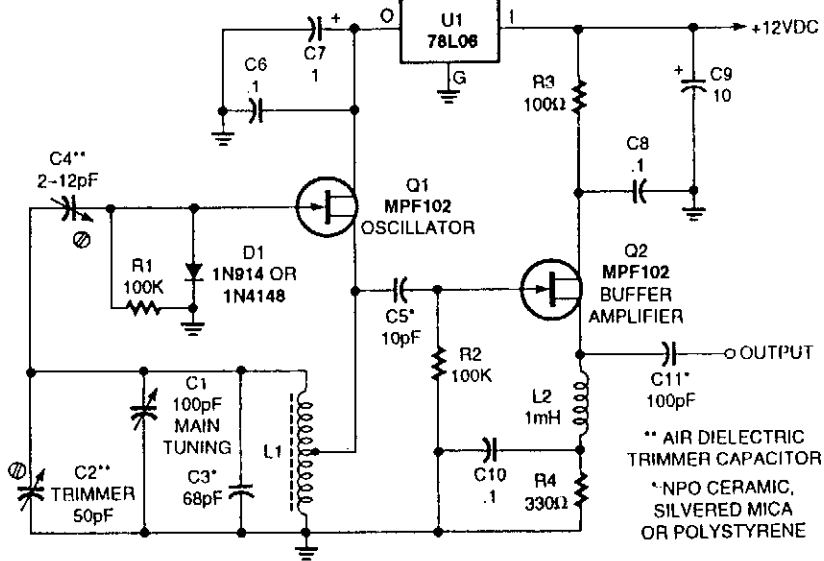

POPULAR ELECTRONICS

Fig. 63-12

This typical HF VFO circuit has several stability-enhancing features, including well-chosen capacitor types. The frequency of the VFO is approximately $2\pi (C_1 + C_2 + C_3) L_1$. L1 should be an air-core type coil, rigidly mounted, with high (>200 value) value of Q.

DARLINGTON TRANSISTOR OSCILLATOR

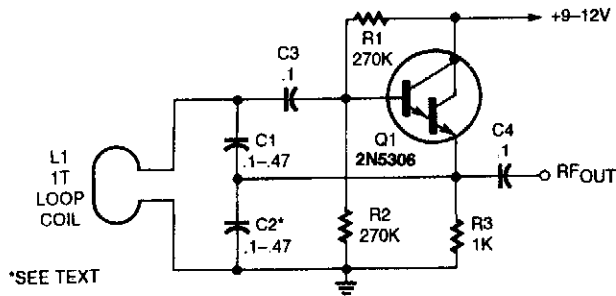

POPULAR ELECTRONICS

Fig. 63-13

This oscillator uses a very large capacitance-to-inductance ratio. L1 is a one-turn coil consisting of a loop of #12 wire 12" in diameter. This circuit is useful for metal detectors, etc., where a loop antenna is used.

FM HF OSCILLATOR WITH NO VARACTOR

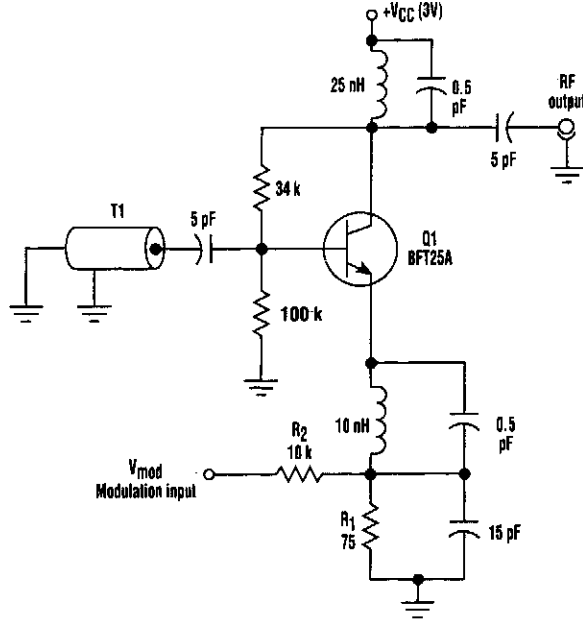

ELECTRONIC DESIGN

Fig. 63-14

Instead of using a varactor to frequency-modulate a high-frequency oscillator, this circuit uses base-charging capacitance modulation. Consequently, the large voltage change required by a varactor, which can be a major problem in battery-powered systems with limited supply voltages, is eliminated. T1 is a ceramic coaxial quarter-wave resonator.

TUNABLE UHF OSCILLATOR

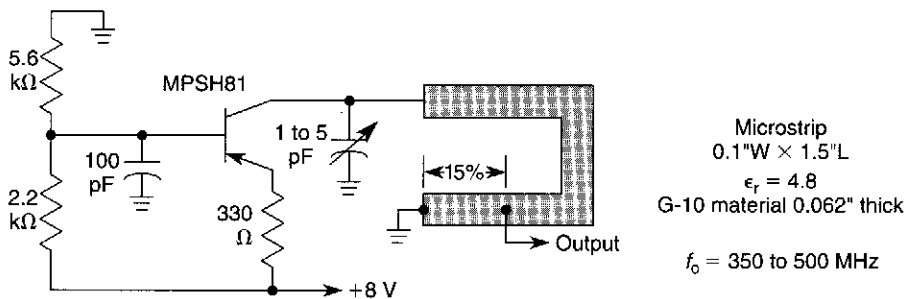

WILLIAM SHEETS

Fig. 63-15

This oscillator is typical for 350- to 500-MHz operation. The microstrip inductor is a PC board trace. The tap is typically 15% from the bottom end. The output power is 55 to 100 mW into 50Ω , with the frequency stability typically 0.1% over 0 to 50°C .

"UNIVERSAL" VFO

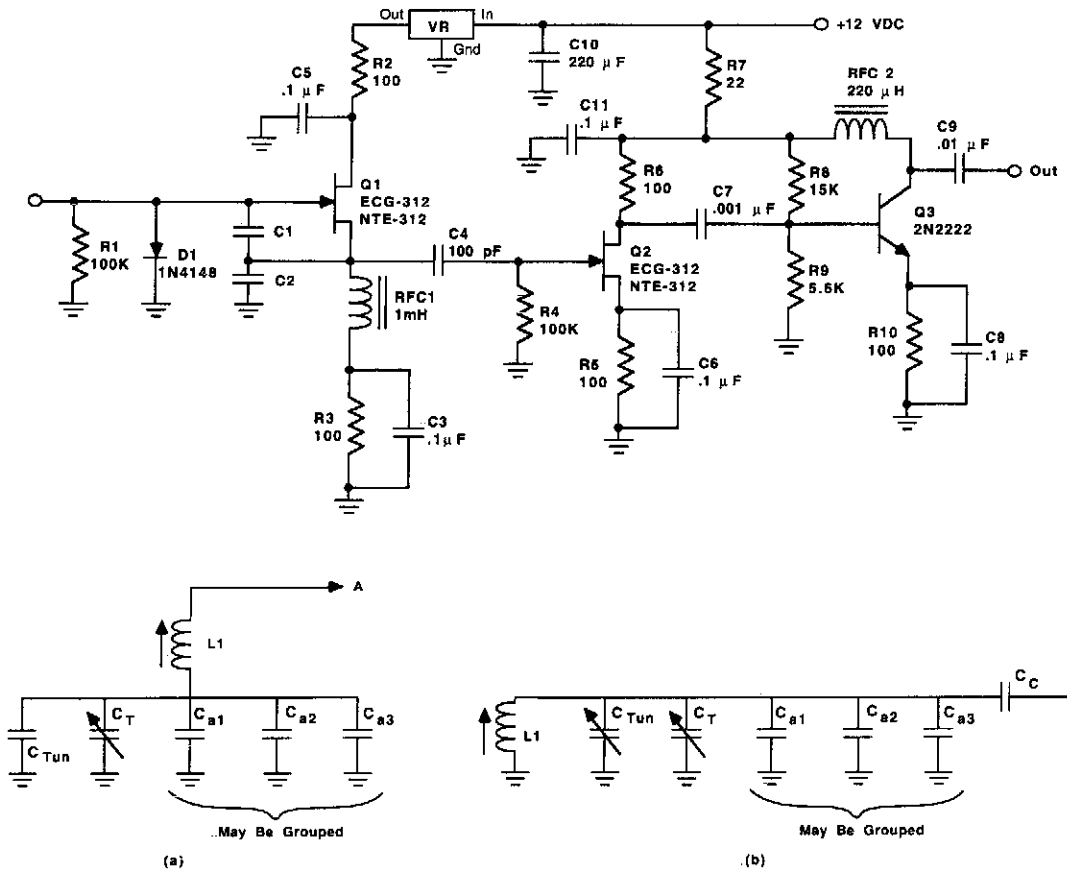

73 AMATEUR RADIO TODAY

Fig. 63-16

Figure 63-16A shows the basic circuit for the VFO, except for the tuning circuits (which are shown in Fig. 63-16B). Transistor Q1 is a junction field-effect transistor (JFET) oscillator stage. The device to use at Q1 includes MPF-102, 2N4416, and the replacement devices from the popular lines of "service" parts e.g., ECG and NTE).

Two different oscillator configurations can be accommodated by this design (i.e., both Clapp and Colpitts oscillators can be built). Both oscillators are the same from point A in Fig. 63-16C forward, and both depend on a capacitor voltage-divider feedback network. The Clapp oscillator (Fig. 63-16A) is series-tuned and the Colpitts oscillator is parallel-tuned (Fig. 63-16B).

The dc voltage supplied to the oscillator transistor (Q1) is voltage-regulated. The voltage regulator can be any 78Lxx series from 78LO5 to 78LO9.

OSCILLATOR CIRCUITS

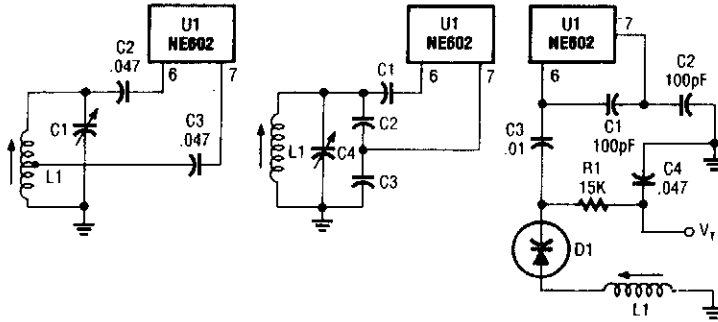

RADIO CRAFT

These are methods of using an NE602 with a tunable VFO.

Fig. 63-17

COLPITTS OSCILLATOR

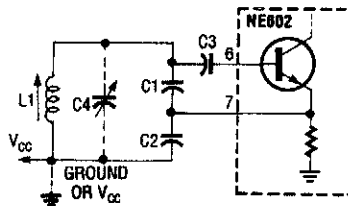

RADIO-ELECTRONICS

Fig. 63-18

$$L_1 \approx 7 \mu\text{H}/f(\text{in MHz})$$

$$C_1 \approx C_2 \approx C_3 \approx 2400 \text{ pF}/f$$

In this circuit, the oscillator is free-running.

CLAPP OSCILLATOR FOR 100 kHz

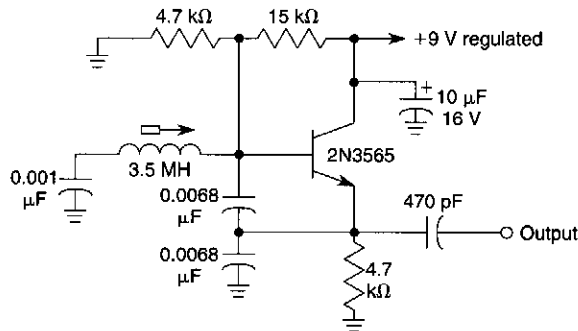

WILLIAM SHEETS

Fig. 63-19

This Colpitts oscillator is very stable and usable where good stability is needed, but crystal control is not desirable. It is capable of 1 part in 10^4 to 10^5 with good-quality components.

TUNED COLLECTOR OSCILLATOR

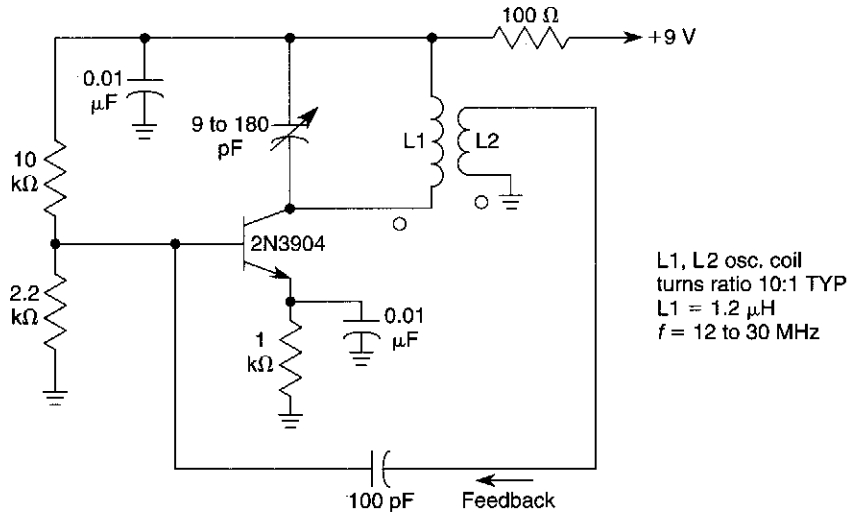

WILLIAM SHEETS

Fig. 63-20

HARTLEY OSCILLATOR

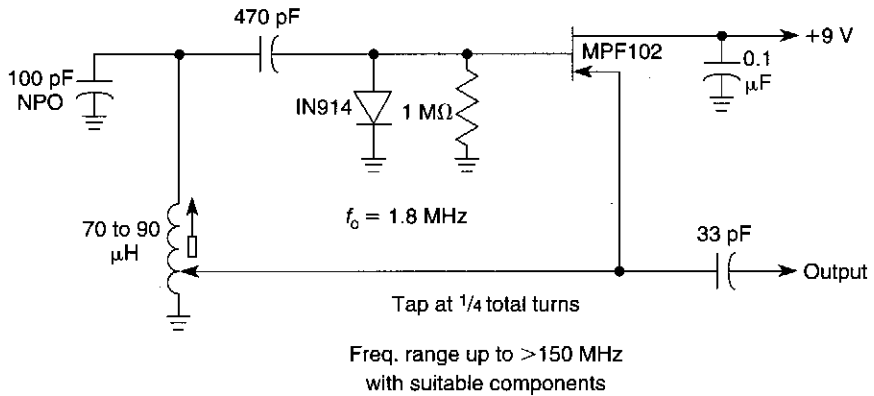

WILLIAM SHEETS

Fig. 63-21

This circuit uses a tapped inductor in a Hartley oscillator circuit. The tap is generally at 25 to 35% total turns in most instances.

64

Oscilloscope Circuits

The sources of the following circuits are contained in the Sources section, which begins on page 707. The figure number in the box of each circuit correlates to the entry in the Sources section.

Scope Voltage Cursor Adapter
Sampling-Rate Phase Lock
Differential Amplifier for Scopes
Delayed Video Trigger for Scopes

SCOPE VOLTAGE CURSOR ADAPTER

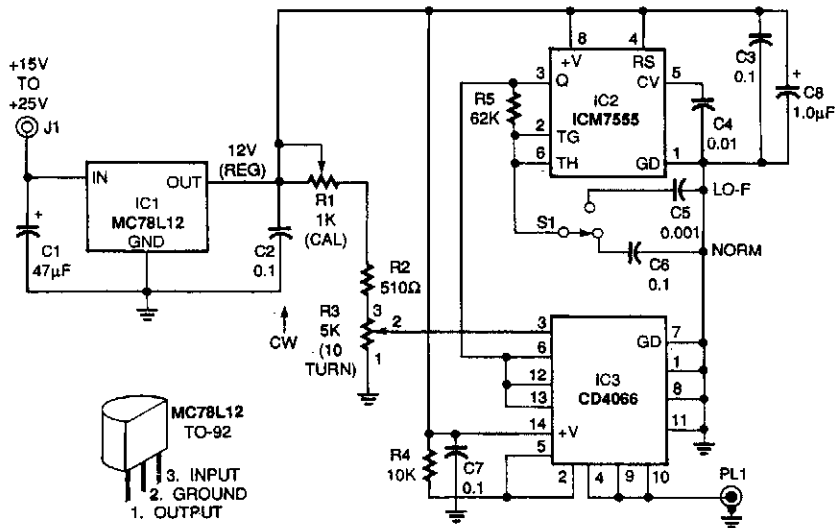

ELECTRONICS NOW

Fig. 64-1

The voltage cursor adapter superimposes horizontal cursor lines on the top and bottom of the waveform—a kind of electronic calipers—to permit direct readout of the voltage value. The cursor lines extend across the entire screen. The MC78L12 voltage regulator (IC1) supplies regulated 12-Vdc to the rest of the circuit. The ICM7555 timer (IC2) drives the CD4066B, a CMOS bilateral switch (IC3). This drive frequency can either be a normal frequency (NORM) of 100 Hz or a low-frequency (LO-F) of 10 kHz, depending on the setting of switch S1. Set S1 to LO-F for inputs below 500 Hz.

The dc reference voltage supplied to pin 3 of IC3 is set by R3, a 10-turn, 5000-Ω precision potentiometer. The voltage can be read directly from a turns counter dial coupled directly to the potentiometer's wiper. The accuracy of this reading can be 1% or better. Trimmer potentiometer R1 permits the voltage to R3 to be calibrated to precisely 10 V.

The circuit is calibrated by setting the digital reading on the turns counter of R3 to the full clockwise position and adjusting R1 for a reading of 10 V at the wiper of R3 with a digital voltmeter.

Bilateral switch IC3 converts the dc reference to a square wave with exactly the same wiper amplitude. The square-wave output appears on common pins 4, 9, and 10 of IC3 and coaxial plug PL1.

SAMPLING-RATE PHASE LOCK

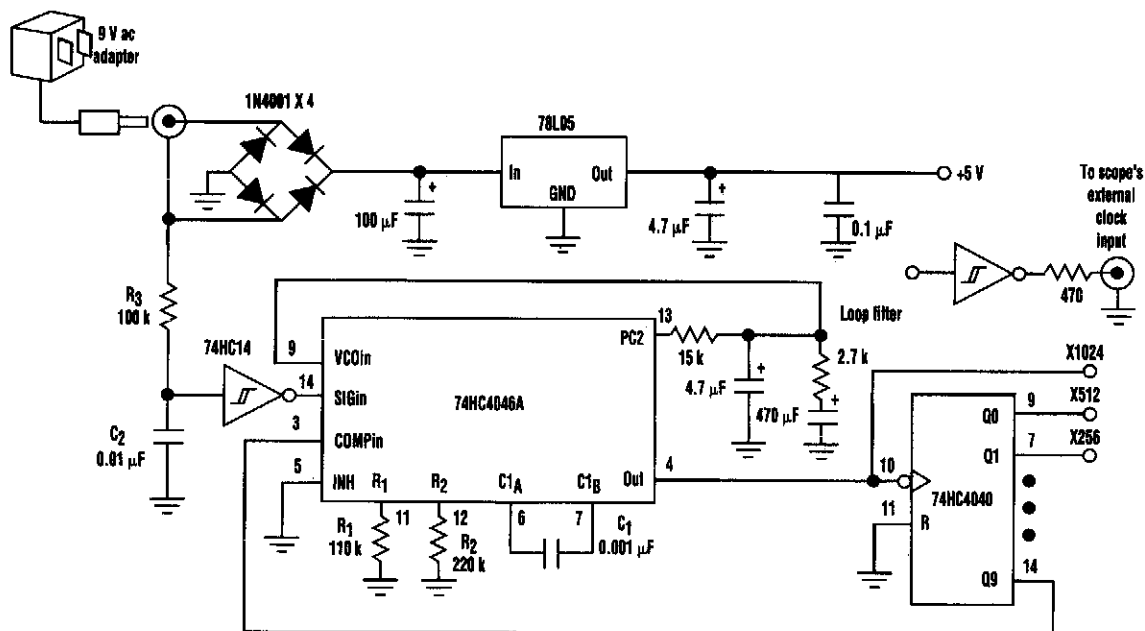

ELECTRONIC DESIGN

Fig. 64-2

Most digital scopes have record lengths that are power of 2 (c.g., 1024 points) and sampling rates constrained to a 1-2-5 sequence. This can lead to measurement errors on power-line waveforms because an integral number of line cycles can't be captured. Digital scopes that calculate measurements, such as the rms level, across the entire record will be in error.

One solution to this problem is to phase-lock the scope's sampling rate to the line frequency by exploiting the external clock input found on some digital scopes. Phase-locking the sampling to line frequency also tracks variations in the power-line frequency.

A 9- or 12-Vac wall transformer provides the circuit's power and the frequency reference. The negative output of the diode bridge refines the circuit ground. The 78L05 regulator provides the +5-V supply for the three ICs. R3 and C2 create a low-pass filter on the half-cycles from one of the floating transformer outputs. R3 also limits the current into the internal diode clamps of the inverter gate. The inverter output becomes the power-line frequency reference and is one input (SIG in to the phase comparator) of the Signetics 74HC4046A phase-locked loop (PLL). The 74HC4040 divides the PLL output frequency by 1024 and feeds the divided clock back to the other PLL phase-comparator input (COMP in). The phase-comparator output (PC2) is filtered and drives the PLL's control voltage (VCO in) so that the output frequency is 1024 times the reference frequency.

With the loop filter shown, the output frequency locks to the line frequency in about 10 s. The oscillator is locked to both 50- and 60-Hz inputs using a 74HC4046A and the values shown for resistors R1 and R2 and capacitor C1.

The output signal is buffered and sent to the scope's external clock input, which is typically a TTL-compatible input. A different tap from the 74HC4040 can be selected to control the number of cycles captured in one scope record.

DIFFERENTIAL AMPLIFIER FOR SCOPES

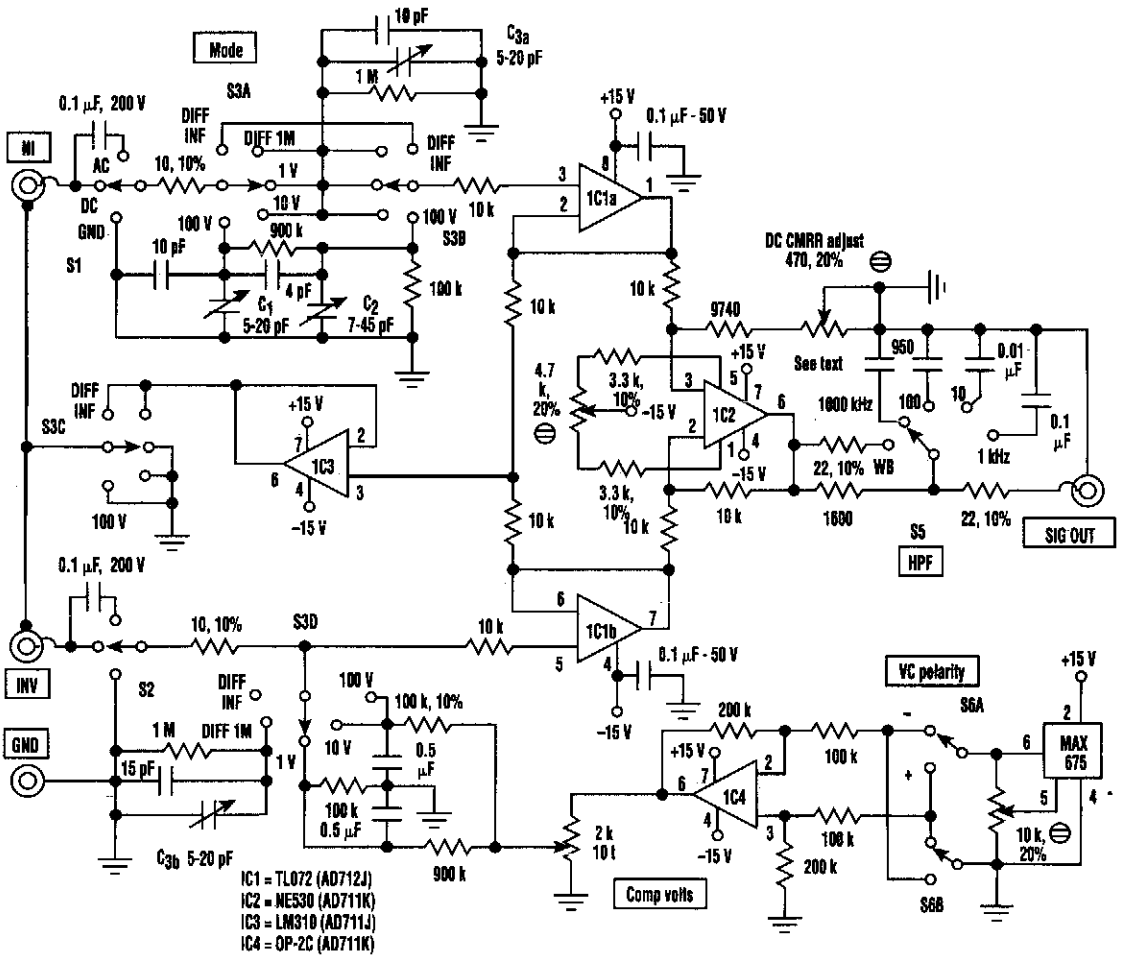

ELECTRONIC DESIGN

Fig. 64-3

Differential inputs and comparator modes can be added to any general-purpose oscilloscope using this circuit setup. Calibration doesn't change because the circuit operates in unity gain in most modes. Amplifier noise level is low enough not to degrade low-level signals, and its dynamic range can handle signals up to ± 12 V peak. Notice that all of the resistors are 1%, unless specified otherwise.

DELAYED VIDEO TRIGGER FOR SCOPES

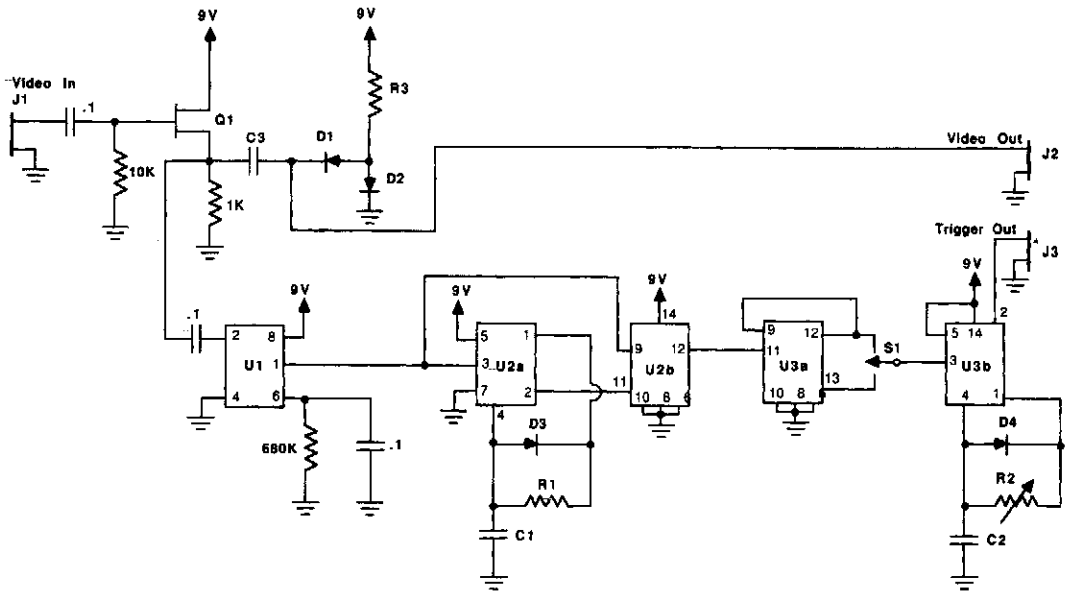

R1	3.3k	D1,D2,D3,D4	1N914 silicon diode
R2	1 meg potentiometer, linear taper	Q1	MPF102 JFET
R3	1k	U1	LM1881 video sync separator
C1	0.0047 μF	U2,U3	4013 D type flip-flop
C2	0.033 μF	J1,J2,J3	RCA phono jack
C3	0.1 μF	S1	SPDT switch

Note: Resistors are all 5% 1/4 watt. Capacitors are all polyester type.

This circuit will extract vertical sync from a video signal, produce a vertical sync pulse, and add an adjustable delay. This permits a delayed sweep effect to enable a scope to look at any particular horizontal line. It is useful for older scopes.

65

Photography-Related Circuits

The sources of the following circuits are contained in the Sources section, which begins on page 707. The figure number in the box of each circuit correlates to the entry in the Sources section.

Charger for Photoflash Capacitor
Slide Stepper
Photo Super Strobe

CHARGER FOR PHOTOFLASH CAPACITOR

- C1—0.2 μF $\pm 20\%$, 100 V
 - C (Load Capacitor)—480 μF , 500 V
 - D1, D2—MR814 (Fast-Recovery Rectifier)
 - Q1—MPS6520 (Selected)
 - Q2—MPS6563 (Selected)
 - Q3—MPS6562 (Selected)
 - Q4—MP3613 (Selected)
 - VR—Neon Lamp (Selected 5 AG)
 - R1—39K
 - R2—100 Ω
 - R3—1.0K
 - R4—120 Ω
 - R5—150 Ω
 - R6—270 Ω $\pm 5\%$
 - R7—7.5 Ω $\pm 5\%$
 - R8—1.0 M Ω
 - R9—2.0 M Ω Pot
 - R10—390K $\pm 5\%$
- Note: All resistors $\pm 10\%$, 1/4 W, Unless Otherwise Specified

L1: Timing Inductor

- Core: Ferroxcube 266T125-3E2A
- Winding: 145 Turns, No. 36 Wire

L2: Drive-Oscillator Transformer

- Core: Ferroxcube No. 18/11PL00-3B7
- Bobbin: 1811F2D
- Air Gap: 0.005 in
- Windings: W1: 40 Turns, No. 28 Wire
- W2: 20 Turns, No. 30 Wire
- W3: 140 Turns, No. 36 Wire

L3: Output Transformer

- Core: Ferroxcube No. 26/16P-L00-3B7
- Bobbin: Ferroxcube No. 26/16F2D
- Windings: N1: 11 Turns, No. 18 Wire
- N2: 1100 Turns, No. 38 Wire
- Air Gap: 0.030 in

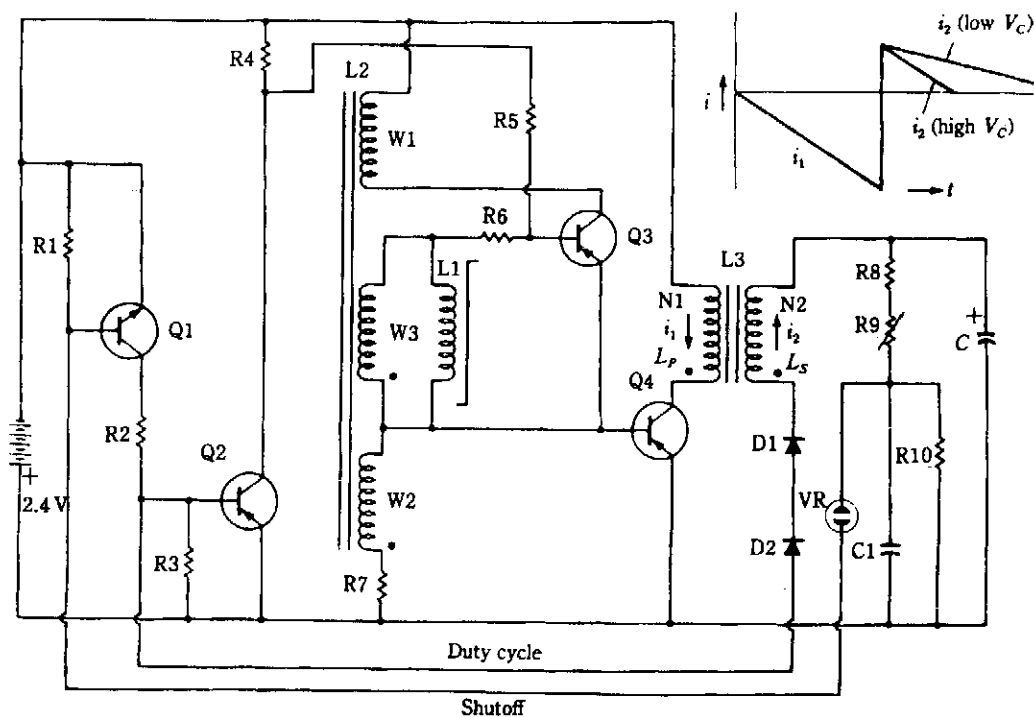

This circuit charges photoflash capacitor C (480 μF , 500 V) for photoflash usage.

SLIDE STEPPER

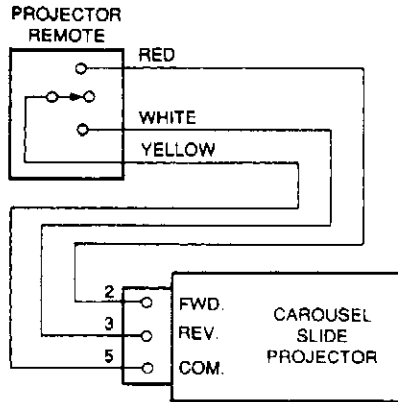

Fig. 1—ORIGINAL CONFIGURATION of the slide projector's remote control.

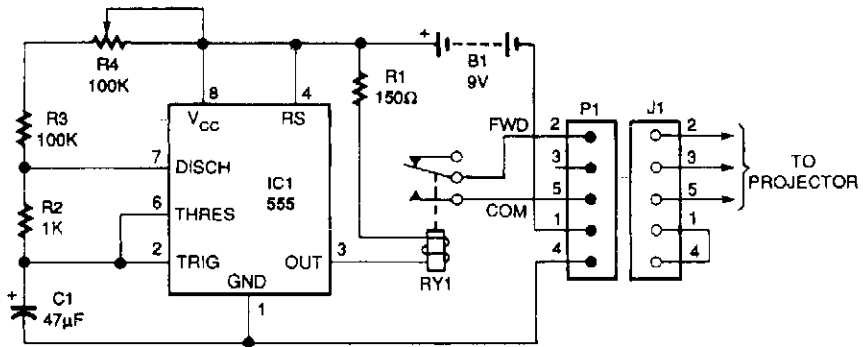

Fig. 2—SCHEMATIC DIAGRAM. The stepper circuit replaces the remote and will automatically advance the slides with a variable time delay.

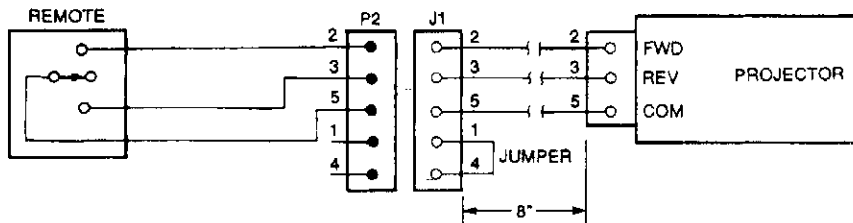
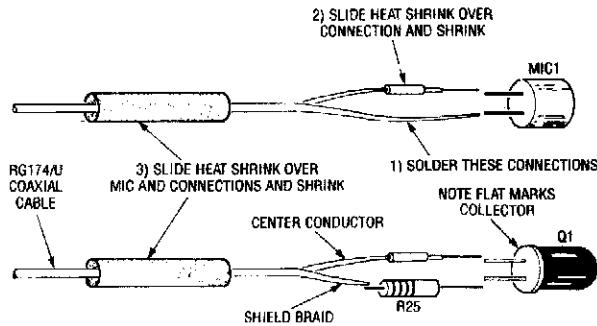
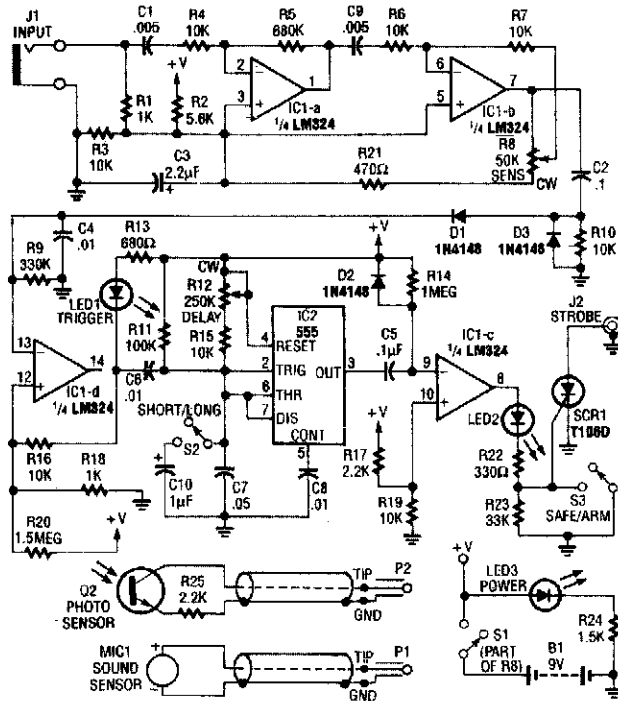

Fig. 3—CABLE MODIFICATION. This will allow the remote and the stepper circuit to be swapped easily.

This stepper circuit replaces remote controls and will automatically advance slides in a projector. The time delay is variable with R4. The cable connections are for a Kodak carousel slide projector.

PHOTO SUPER STROBE



MAKE THE SENSOR ASSEMBLIES with heat-shrink tubing and small diameter coaxial cable such as RG-174-U. The space between the coaxial cable and the outer heat-shrink tubing is filled with a little silicone rubber.

ELECTRONICS NOW!

Fig. 65-3

A change in audio or light level on the sensor connected to J1 is amplified by IC1-a and IC1-b (rectified), and used to trigger IC2. R12 sets the delay between the trigger and the flash. IC1-c drives indicator LED2 and triggers SCR1, which sets off the strobe connected to J2. A photo cell or a microphone can be used as a sensor.

66

Piezo Circuits

The sources of the following circuits are contained in the Sources section, which begins on page 707. The figure number in the box of each circuit correlates to the entry in the Sources section.

Piezoelectric Driver Circuit
Piezoelectric Buffer

PIEZOELECTRIC DRIVER CIRCUIT

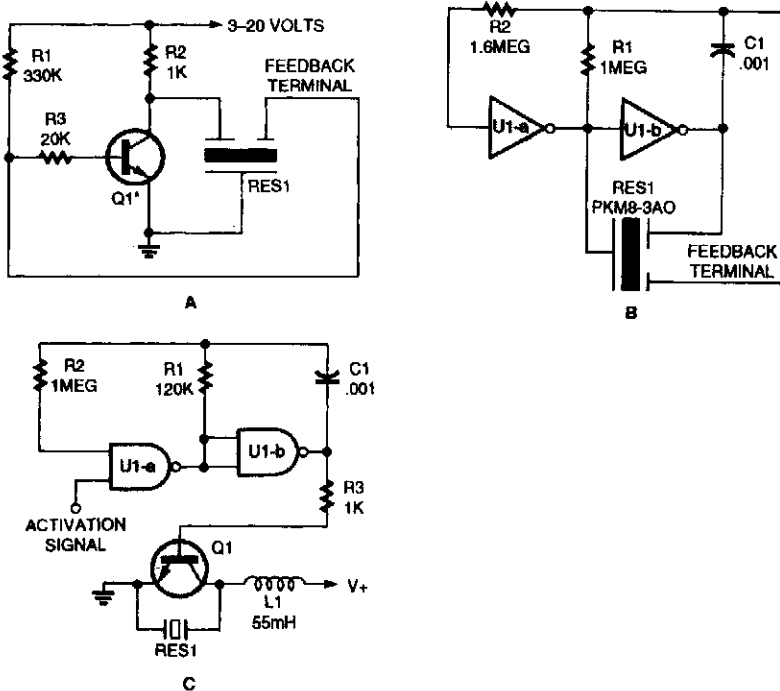

POPULAR ELECTRONICS

Fig. 66-1

Three-terminal piezoelectric elements are typically driven by transistor circuits (A), or logic gates (B). Two-terminal devices can be driven by two NAND gates. A booster coil is used to compensate for the sound-pressure attenuation caused by the case.

PIEZOELECTRIC BUFFER

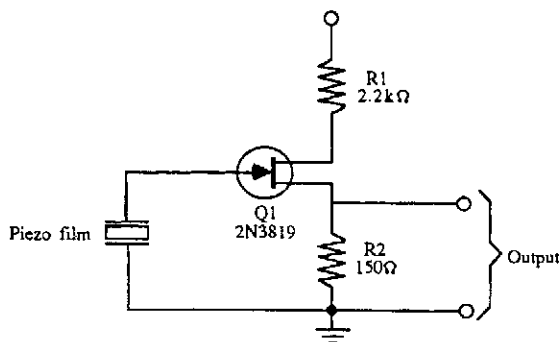

- R1 2.2 kΩ
 - R2 150 Ω
 - Q1 2N3819 FET transistor
 - Misc. Piezo disc
- All resistors are 5 to 10 percent tolerance, 1/4 watt.

McGRAW-HILL

Fig. 66-2

This circuit will serve as a buffer for experiments with Kynar film, a piezoelectric material, or with piezo devices.

67

Power Line Circuits

The sources of the following circuits are contained in the Sources section, which begins on page 707. The figure number in the box of each circuit correlates to the entry in the Sources section.

ac Power Controller
ac Power-Line Monitor
Power-Line Modem for Computer Control
Low-Voltage Power Controller

ac POWER CONTROLLER

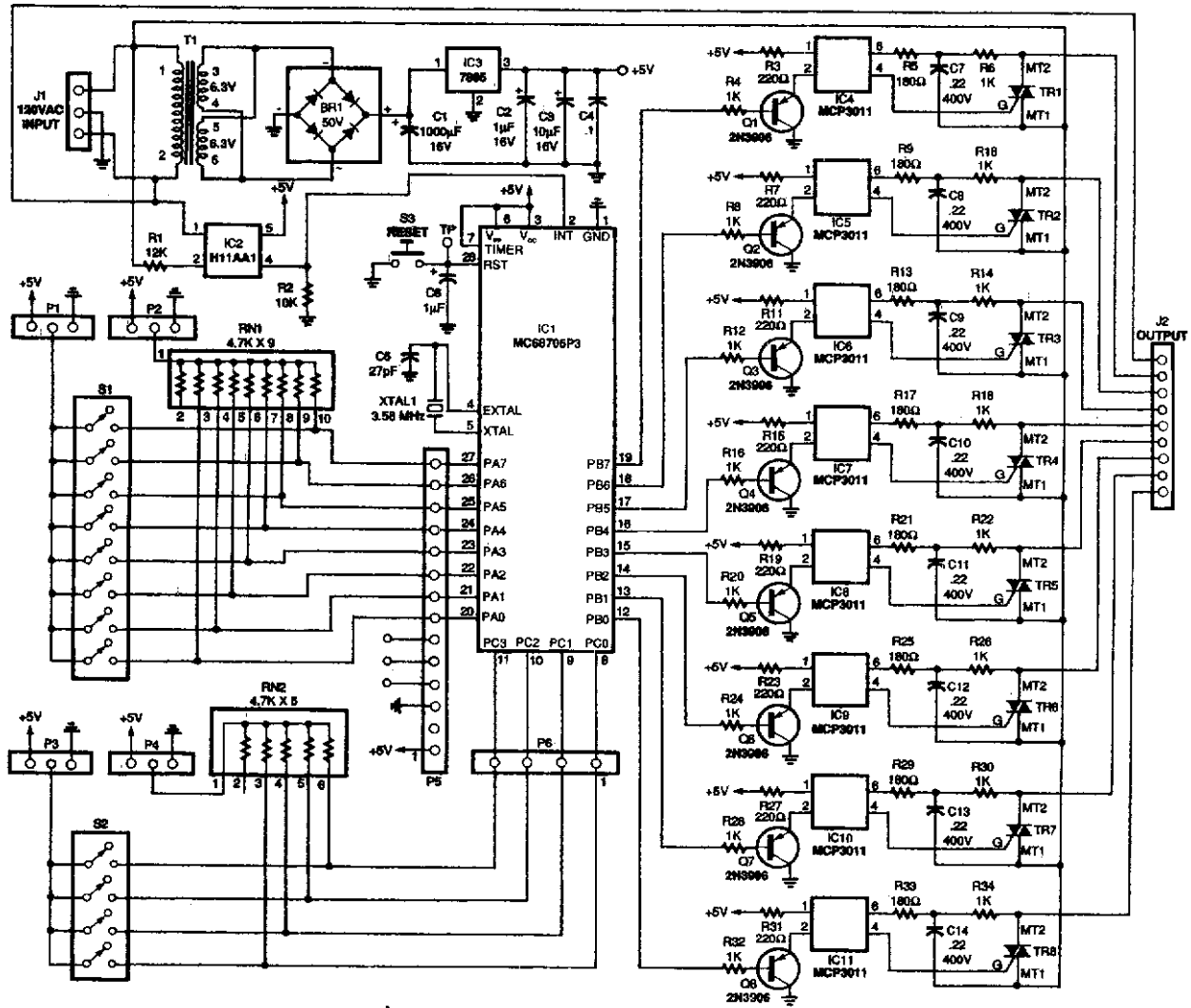

ac POWER CONTROLLER (Cont.)

This circuit is used to vary the power delivered to a 120-Vac load under software control. A 68705 micro controller can control eight discrete power triacs, each of which delivers power in 32 smoothly graduated steps, ranging from 0 to 97% of full power. The value delivered to one channel is independent of the value delivered to any other channel. Loads can include light displays, universal motors, heaters, and other appliances.

The power level is set by software, not a potentiometer. The software includes a basic set of routines for processing interrupts and setting the power level. The software also includes five test and demonstration routines for putting the circuit through its paces. Moreover, there's plenty of room to add your own routines to the 68705's built-in EPROM.

The basic circuit is simple, yet versatile enough to accept inputs from on-board DIP switches; alternatively, the inputs can be driven from a microcomputer bus or parallel port, or a stand-alone device with TTL-compatible outputs. There are 12 input bits to set modes and specify values.

ac POWER-LINE MONITOR

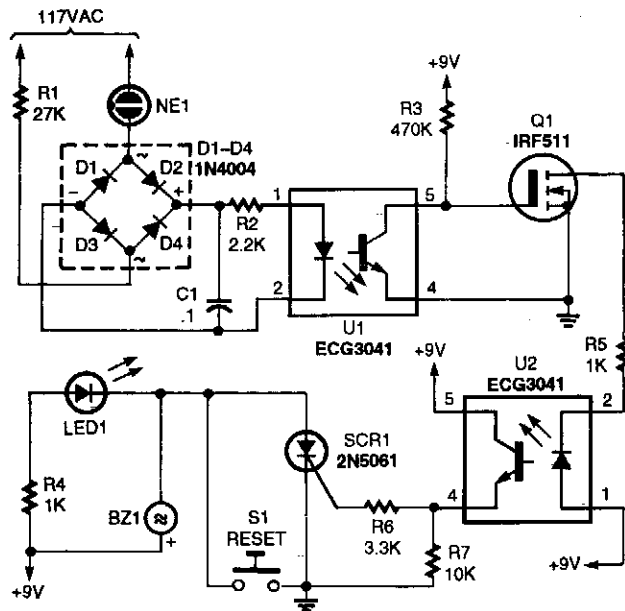

POPULAR ELECTRONICS

Fig. 67-2

When the power-line voltage source fails, Q1 turns on, activates optoisolator U2, and triggers SCR1. For small SCRs, U1 might directly trigger SCR1.

POWER-LINE MODEM FOR COMPUTER CONTROL

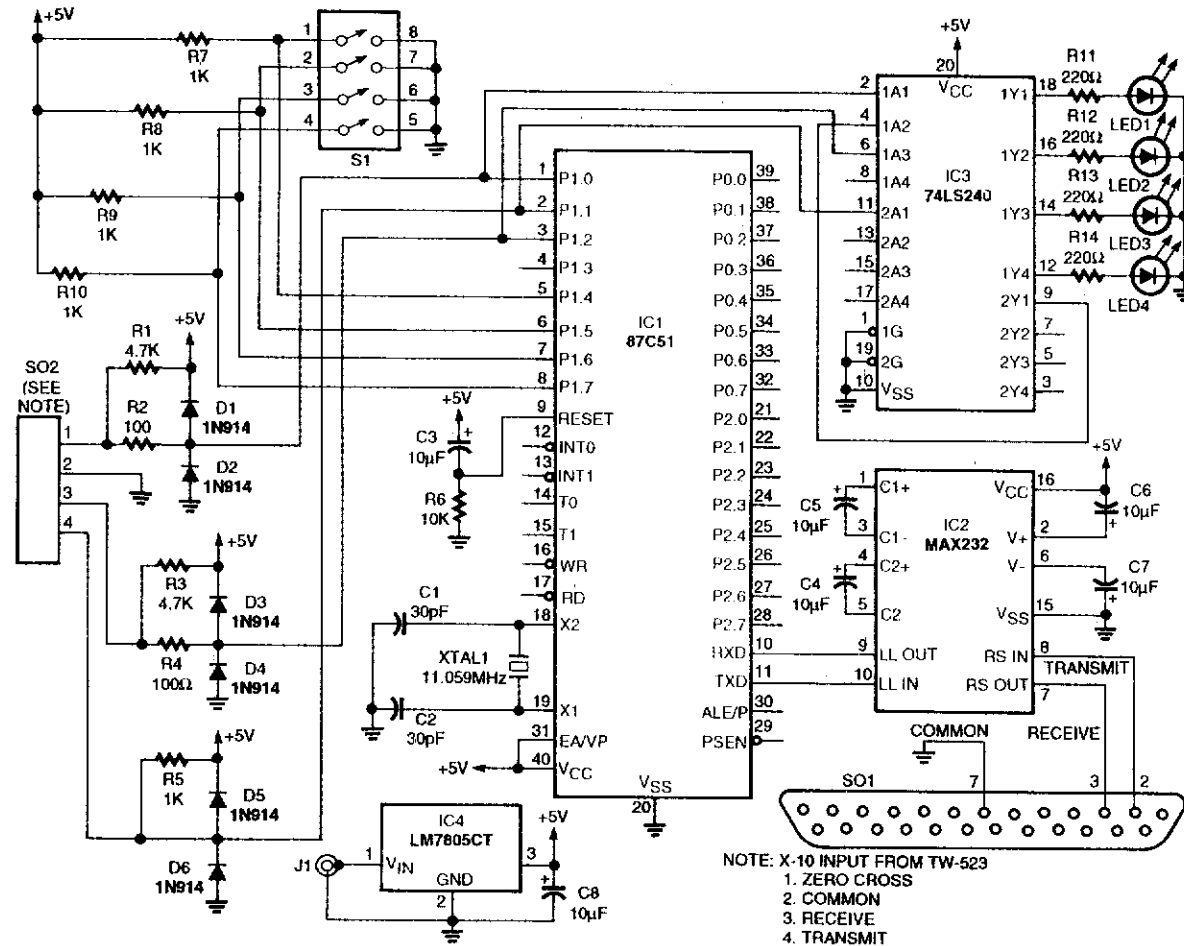

ELECTRONICS NOW

Fig. 67-3

This circuit uses an 87C57 microcontroller and a few peripherals to condition X-10 power-line carrier-code formats from a personal computer to use an X-10 power-line interface in a home-control system. Software details are available in the reference.

LOW-VOLTAGE POWER CONTROLLER

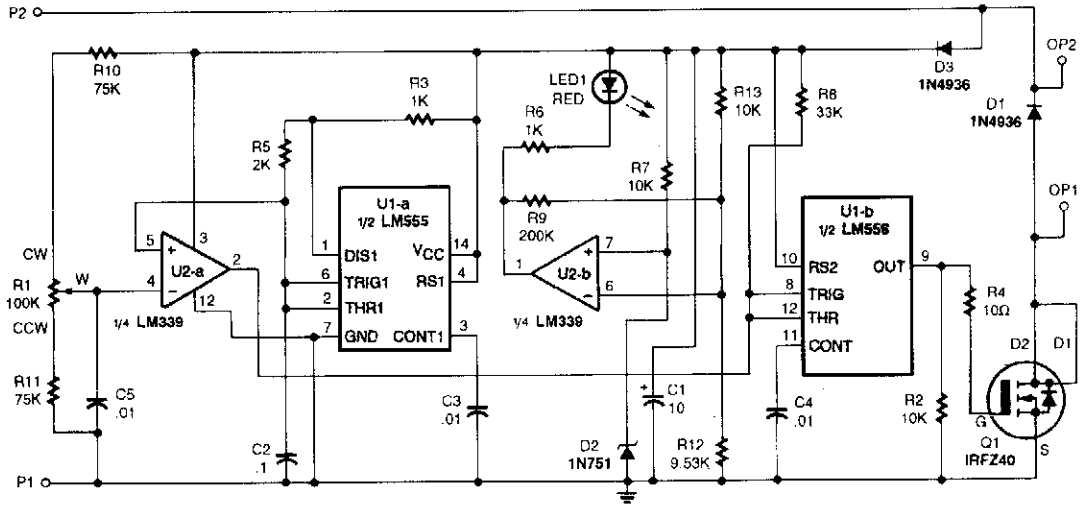

POPULAR ELECTRONICS

Fig. 67-4

The circuit has a duty-cycle generator that will produce an output varying from fully off to fully on and pulses of any duty cycle in between the two extremes.

This method of operation is called *PWM* (*pulse width modulation*). The circuit can be fed from any dc supply source of between 10 to 15 V. Half of an LM556 dual oscillator/timer and U2-a (¼ of an LM339 quad comparator) combine to form a voltage-to-pulse-width converter. The first half of the dual oscillator/timer (U1-a) is configured as an astable oscillator, generating a continuously oscillating ramp voltage. Op amp U2-a compares the voltage at its noninverting input (pin 5)—which is connected to pins 2 and 6 of U1-a—to the voltage at its inverting input (pin 4). The op amp will produce a low output if R1's wiper voltage is higher than the instantaneous voltage that is present at pins 2 and 6 of U1-a. The output of U2-a at pin 2 will have an on/off ratio that is proportional to the voltage at R1's wiper.

The output of U2-a is fed to U1-b, which is used to buffer the signal. The low-impedance, pulsed output of U1-b at pin 9 is fed to the gate of MOSFET Q1, driving it on or off. The circuit also has a power-input detector, built around U2-b and LED1. If the input power is OK, LED1 will shut off.

Diode D1 is used to suppress the reverse voltage spikes that are generated by inductive loads during turn off; without that diode, the MOSFET might be destroyed. If the circuit will not be used to drive inductive loads (motors), D1 can be eliminated.

68

Power Supply Circuits

The sources of the following circuits are contained in the Sources section, which begins on page 707. The figure number in the box of each circuit correlates to the entry in the Sources section.

Foldback Current Limiter	Two-Terminal 100-mA Current Regulator
Current-Limiting Regulator Circuit	Two-Phase Rectifier
Switching Power Supply	Low-Noise 5-V Supply
Transformerless dc Power Supply I	Positive Regulator with 0- to 70-V Output
+5-V at 1.5- to 3-A Supply, +6- to +15-V Input	Simple 12-V Power Supply
Transformerless dc Power Supply II	3.3 V from 5-V Logic Supplies
Fast 3.3-V Regulator	12-V Supply
Power Supply for High-Power Autosound Amp	4- to 70-V Regulator
IC Regulator Protection	Switched Power-Control Circuits
3.3-V Switching Regulator	Multiple On-Card Regulator Adjuster
NE602 Power-Supply Options	Simple 9-V Power Supply
Simple 9-V Power Supply	+5-V at 1-A Supply with +3- to +5-V Input
Tracking Power Supply	5-Vdc Regulated Supply
Power Efficient Voltage Regulator	Buffered Reference Supply
Low Drop-Out Regulator	5-V Logic Regulator with Electronic Shutdown
SCR Switching Supply for Color TV Receivers	12-Vdc Regulated Supply
Regulator Circuit for Bilateral	Junked Transistor Regulators
Source/Load Power System	Teleprinter Loop Supply
Fast 3.3-V Adjustable Regulator	5-A Constant-Voltage Supply

FOLDBACK CURRENT LIMITER

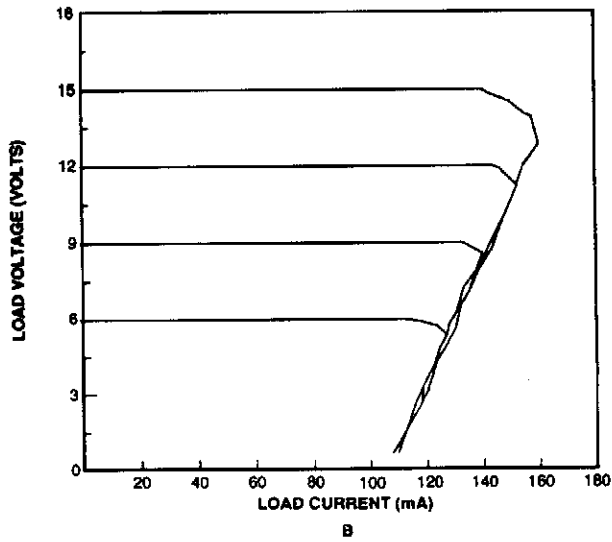
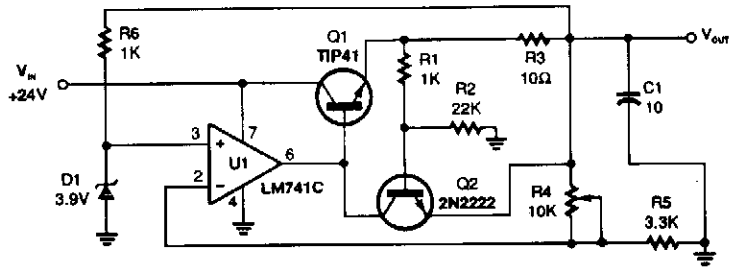

This regulator uses the drop across R3 to sense current draw, turning on Q2, removing drive from Q1, and lowering the output voltage. Limiting occurs when Q2 has 0.65 V across the base-emitter junction. This circuit has foldback characteristics as seen from the figure.

CURRENT-LIMITING REGULATOR CIRCUIT

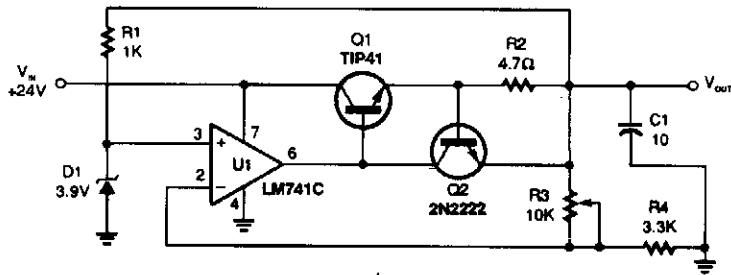

A

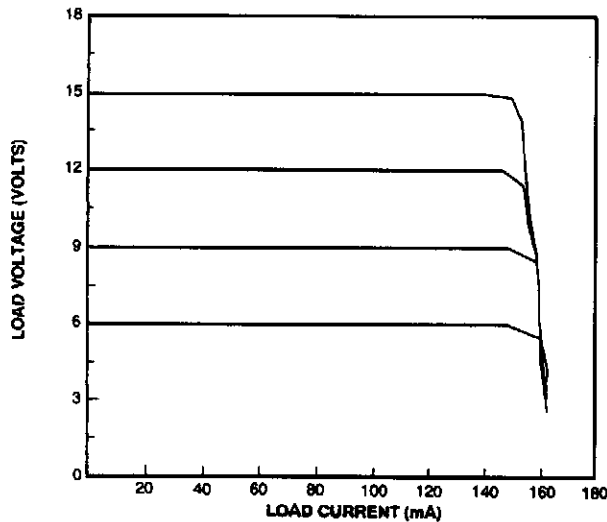

B

As shown in B, maximum load current is practically the same at all supply voltages with constant current limiting.

POPULAR ELECTRONICS

Fig. 68-2

This regulator uses the drop across R2 to turn on Q2, removing base drive from Q1 and reducing the current through R1. About 0.65 V must be dropped across R2 before limiting occurs. To set limit current,

$$R_2 \approx \frac{0.65}{I_{\text{LIMIT (amps)}}}$$

$$\text{Output voltage} = V_{\text{OUT}} = (3.9) \frac{(R_3 + R_4)}{R_4}$$

SWITCHING POWER SUPPLY

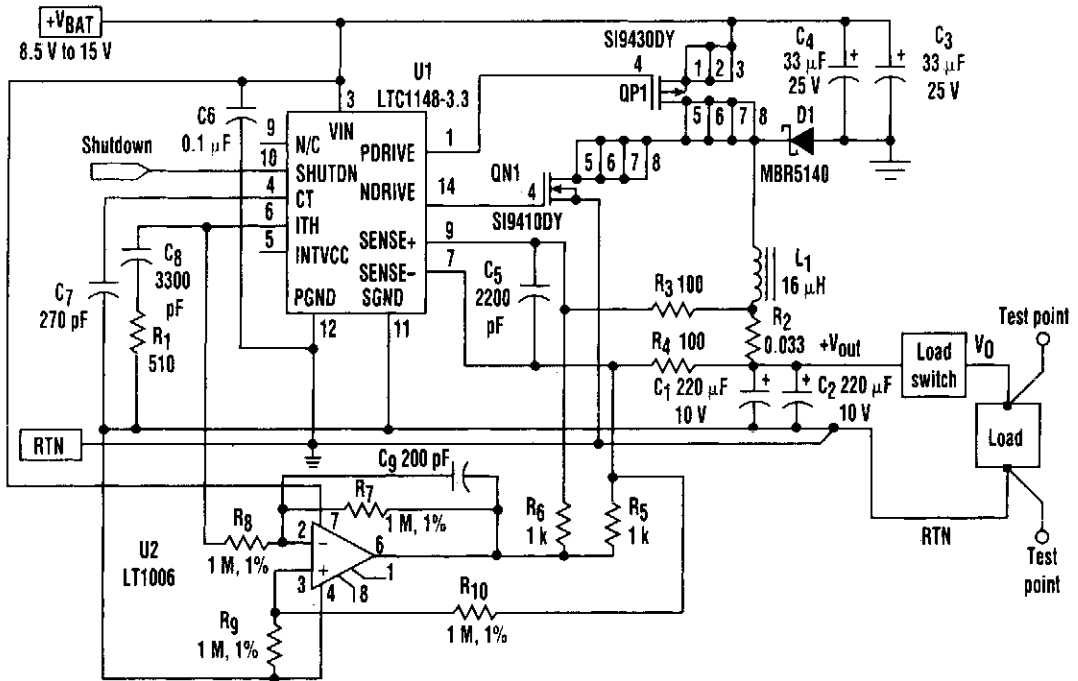

ELECTRONIC DESIGN

Fig. 68-3

In many switching-regulator applications for portable computers, the microprocessor is located some distance from the power supply. With the latest processors, total load currents range into several amperes. Thus, regulation at the load can become a problem.

The I_{TH} pin (pin 6) of the LTC1148 is approximately proportional to the load current. It scales nearly linearly from 0 V at no load to 2.0 V at current limit. U2, acting as a unity-gain differential amplifier, inverts the U1 pin 6 voltage (referenced to SENSE—, pin 7) and causes a current proportional to load current to flow in resistors R5 and R6. A small voltage drop appears across current-sense filter resistors R3 and R4. This makes the voltage measured by the internal feedback divider appear low. The duty factor is adjusted to bring this back to the correct voltage. As a result, the output is increased slightly as a function of load. Capacitor C9 rolls off the high-frequency gain of the correction amplifier.

$$R_{comp} = \frac{(V_{pin6} \times R_{fil})}{V_{corr}}$$

where: $R_{comp} = R_5 = R_6$

$R_{fil} = R_3$ and R_4

$V_{corr} = \text{Measured drop.}$

TRANSFORMERLESS dc POWER SUPPLY I

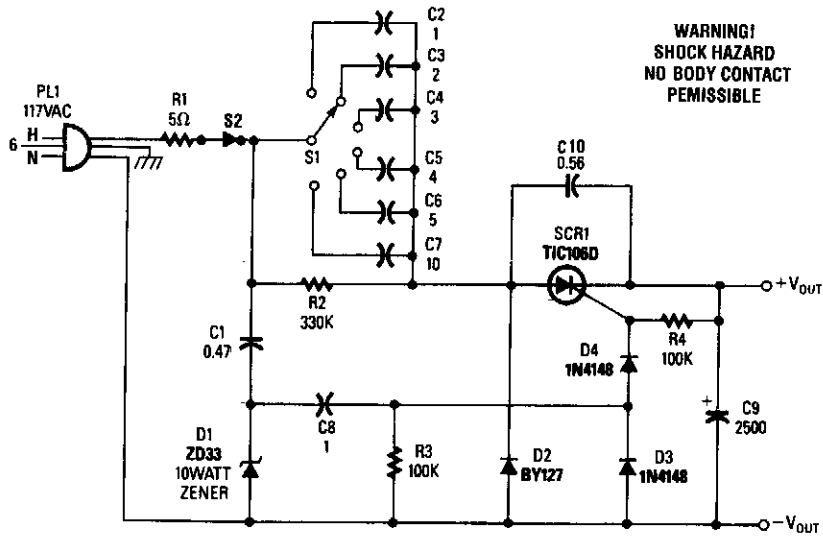
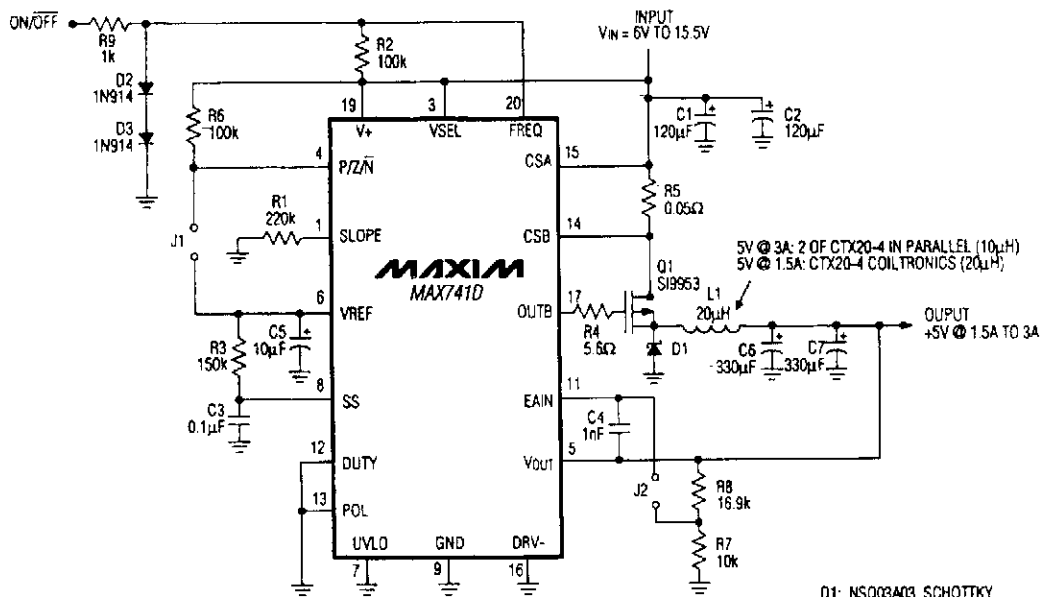

TABLE 1—OUTPUT CURRENT/VOLTAGE AT SPECIFIED LOADS

Capacitance (μ F)	Load					
	100 Ohms		200 Ohms		1000 Ohms	
	V_{OUT} (V)	Current (mA)	V_{OUT} (V)	Current (mA)	V_{OUT} (V)	Current (mA)
1	3.2	31	6.0	29	25	24
2	6.4	61	11.2	54	41	41
3	9.0	87	16.1	78	52	52
4	11.8	113	20.7	100	61	61
5	15.5	147	24.7	120	67	67
6	17.8	169	28.8	140	68	68
7	18.5	176	31.9	155	69.4	68
8	20.3	195	36.8	173	70	71
9	22.8	220	41.0	193	70	71
10	24.9	238	42.0	204	71	71
11	27.1	259	44.9	219	—	—
14	33.0	317	52.7	257	—	—
20	43.5	422	65.8	322	—	—

An SCR fires on the positive half cycles of the ac line voltage. Switched capacitors are used to select the output voltage. These must all be ac-rated, nonpolarized types.

+5-V AT 1.5- TO 3-A SUPPLY, +6- TO +15-V INPUT



MAXIM

Fig. 68-5

Operating efficiencies of 80 to 90% are possible using the MAX741D and this circuit.

TRANSFORMERLESS dc POWER SUPPLY II

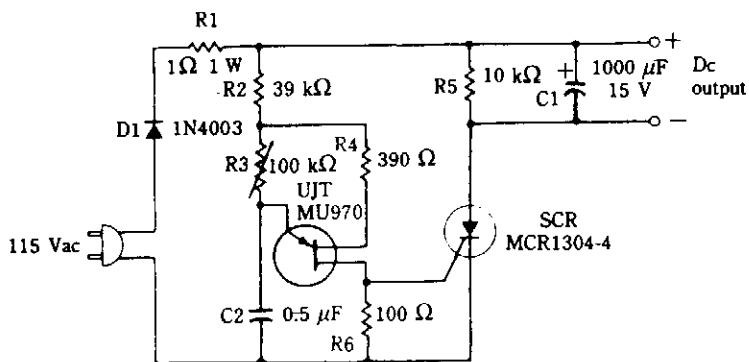

McGRAW-HILL

Fig. 68-6

Although it is simple, this supply can provide 10 to 15 V at 100 mA directly from the ac lines. This circuit has no isolation from the ac line; therefore, there is a shock hazard and it should only be used where no possibility of contacting external devices, circuits, or personnel exists.

FAST 3.3-V REGULATOR

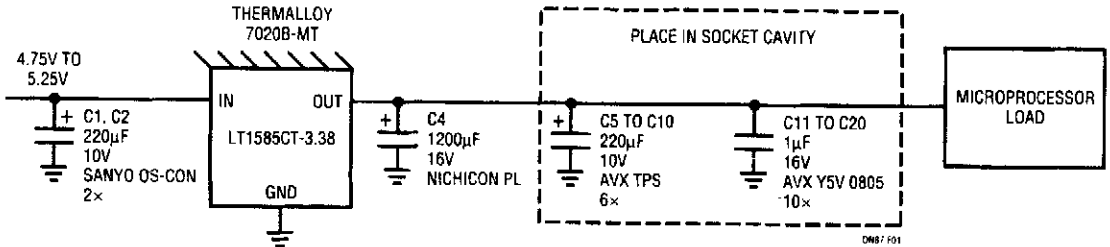

AVX CORPORATION: (803) 448-9411
 NICHICON (AMERICA) CORPORATION: (708) 843-7500
 SANYO VIDEO COMPONENTS (USA) CORPORATION: (619) 661-6322
 THERMALLOY INCORPORATED: (214) 243-4321
 FOR CORRECT OPERATION OF MICROPROCESSOR, DO NOT SUBSTITUTE COMPONENTS

LINEAR TECHNOLOGY

Fig. 68-7

New high-performance microprocessors require a fresh look at power-supply transient response. The LT1585 linear regulator features 1% initial accuracy, excellent temperature drift and load regulation, and virtually perfect line regulation. Complementing superb dc characteristics, the LT1585 exhibits extremely fast response to transients. Transient response is affected by more than the regulator itself. Stray inductances in the layout and bypass capacitors, as well as capacitor ESR dominate the response during the first 400 ns of transient.

The figure shows a bypassing scheme developed to meet all the requirements for the Intel P44C-VR microprocessor. Input capacitors C1 and C2 function primarily to decouple load transients from the 5-V logic supply. The values used here are optimized for a typical 5-V desktop computer "silver box" power-supply input. C5 to C10 provide bulk capacitance at low ESR and ESL, and C11 to C20 keep the capacitance at low ESR and ESL low at high (>100 kHz) frequencies. C4 is a damper and it minimizes ringing during setting. Trace C is the load current step, which is essentially flat at 4 A with a 20-ns rise time.

Trace A is the output settling response at 20 mV per division. Cursor trace B marks -46 mV relative to the initial output voltage. At the onset of load current, the microprocessor socket voltage dips to -38 mV as a result of inductive effects in the board and capacitors, and the ESR of the capacitors. The inductive effects persist for approximately 400 ns. For the next 3 µs, the output droops as the load current drains the bypass capacitors. The trend then reverses as the LT1585 catches up with the load demand, and the output settles after approximately 50 µs. Running 4 A with a 1.7-V drop, the regulator dissipates 6.8 W.

POWER SUPPLY FOR HIGH-POWER AUTOSOUND AMP

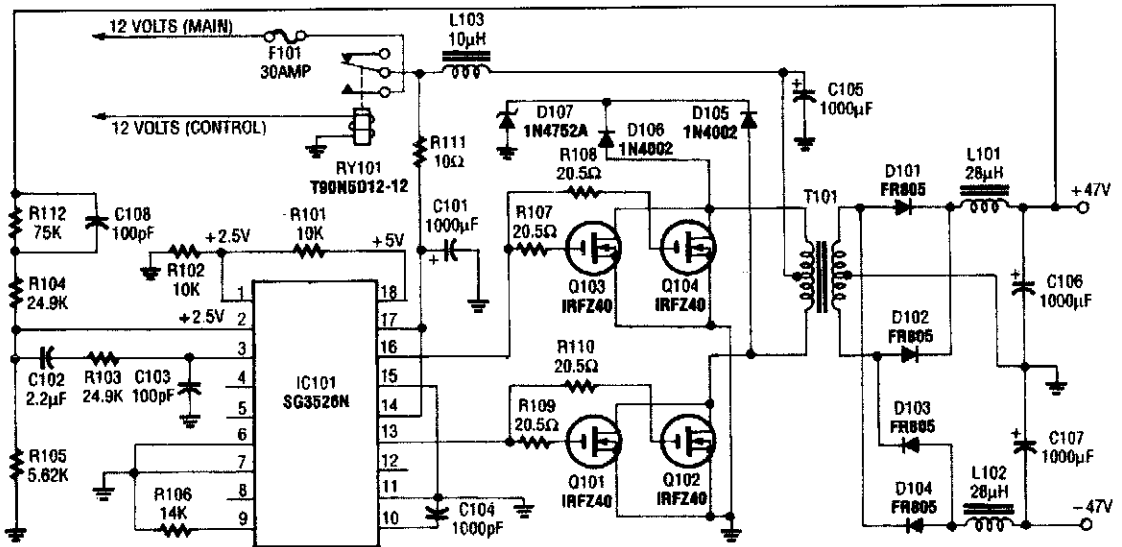

RADIO-ELECTRONICS

Fig. 68-8

A switching mode inverter is used with a pulse-width modulation voltage regulator (SG35260). Four IRF240 power MOSFETs are used as switches. The output is ± 47 V at about 5 A peak. Transformer T101 is a four-turn center tapped primary, and 16-turn center tapped secondary on a Ferroxcube ETD-34 core.

IC REGULATOR PROTECTION

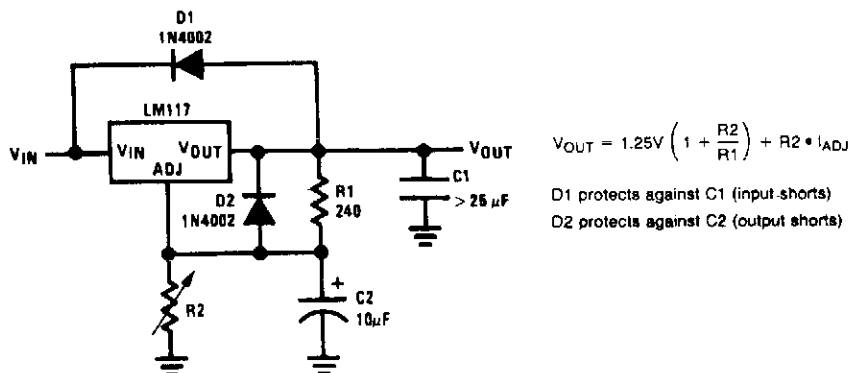

NATIONAL SEMICONDUCTOR

Fig. 68-9

This circuit protects an IC regulator against various fault conditions.

3.3-V SWITCHING REGULATOR

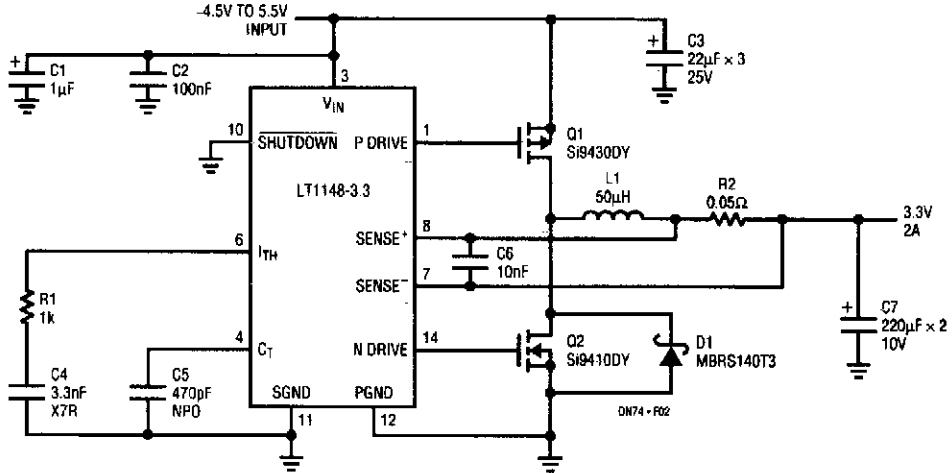

LINEAR TECHNOLOGY

Fig. 68-10

For the LT1129-3.3, dissipation amounts to a little under 1.5 W at full output current. The 5-lead surface-mount DD package handles this without the aid of a heatsink, provided that the device is mounted over at least 2500 mm² of ground or power-supply plane. Efficiency is around 62%; dissipation in linear regulators becomes prohibitive at higher current levels, where they are supplanted by high-efficiency switching regulators. The synchronous buck converter is implemented with an LTC1148 converter. The LTC1148 uses both Burst Mode™ operation and continuous, constant off-time control to regulate the output voltage, and maintain high efficiency across a wide range of output loading conditions.

NE602 POWER-SUPPLY OPTIONS

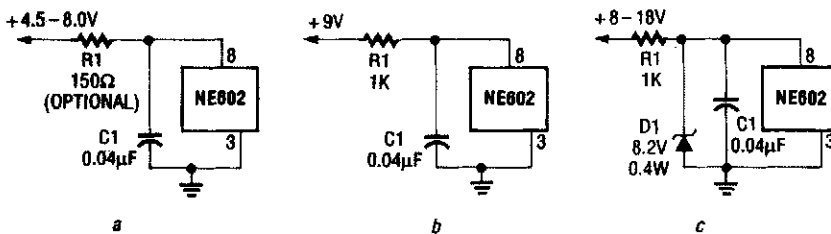

RADIO-ELECTRONICS

Fig. 68-11

Here, Figs. 68-11A through 68-11C show an RC-filter used as both current limiter (R1) and integrator (C1), as well as for isolation. In Fig. 68-11A, +4.5 to 8.0 Vdc is the normal operating range of the NE602. In Fig. 68-11B, R1 drops voltage, and is used because a +9-V battery can go higher, and a +9-V wall supply can produce up to 11 V. In Fig. 68-11C, a +8- to 18-Vdc supply is regulated using a 8.2-V Zener for D1.

SIMPLE 9-V SUPPLY

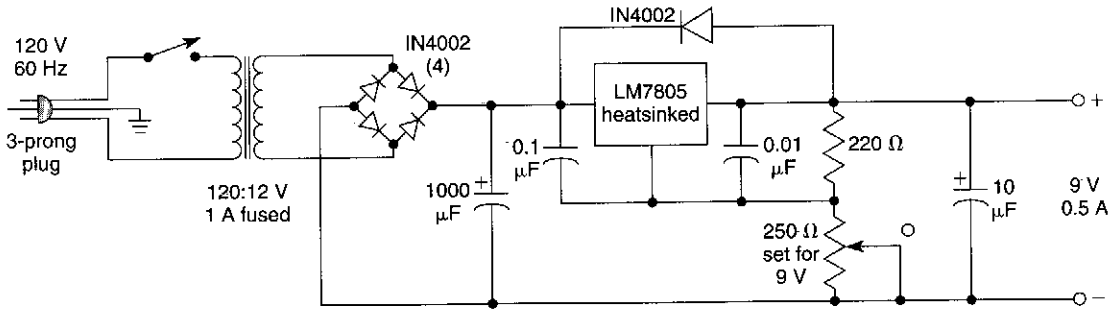

WILLIAM SHEETS

Fig. 68-12

This circuit uses an LM7805 with a resistive voltage divider in the common leg of the regulator. The regulator can be "fooled" into producing an apparent higher output voltage in this manner. This supply is useful for running radios, tape recorders, or other 9-V devices.

TRACKING POWER SUPPLY

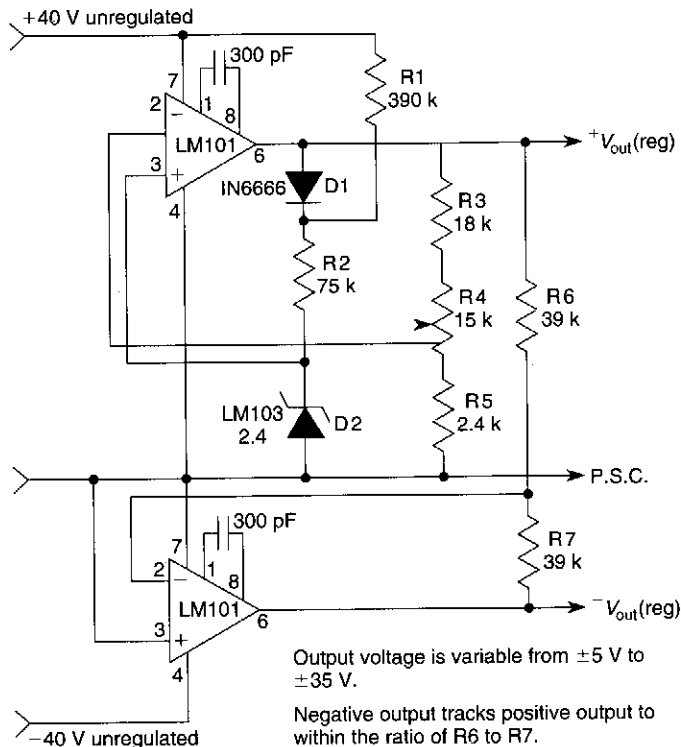

NATIONAL SEMICONDUCTOR

Fig. 68-13

Two op amps are used in this basic op-amp regulator circuit. The outputs can be fed to current amplifier stages or emitter followers, if needed.

POWER EFFICIENT VOLTAGE REGULATOR

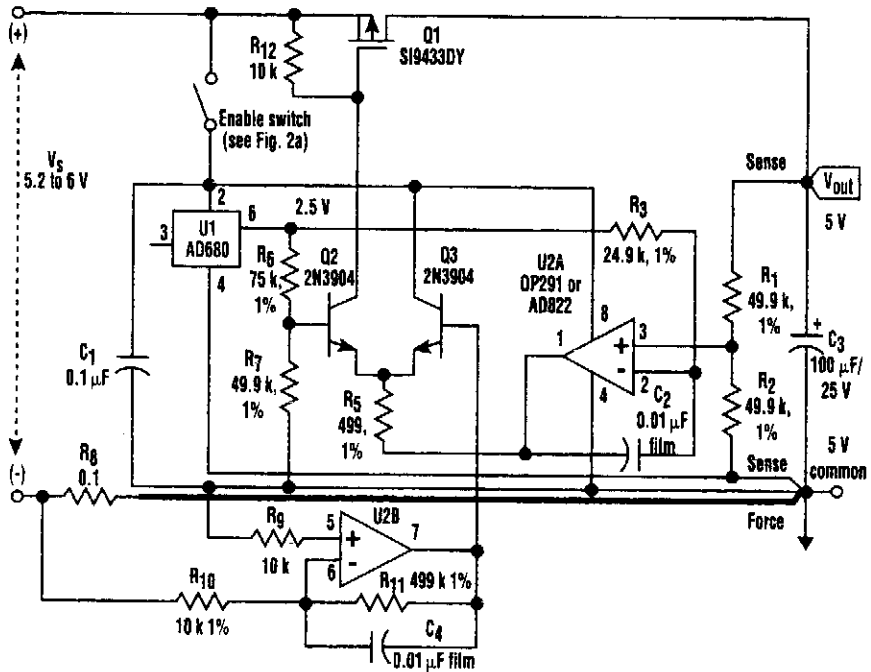

ELECTRONIC DESIGN

Fig. 68-14

Included in the many features of this power-efficient, voltage-regulator circuit is shutdown power control with a current output up to several hundred milliamperes (expandable to amperes, if desired). Current limiting can be preset to a fixed level for controlled dissipation in Q1 and the circuit requires no auxiliary voltage supply for the pass transistor.

LOW DROP-OUT REGULATOR

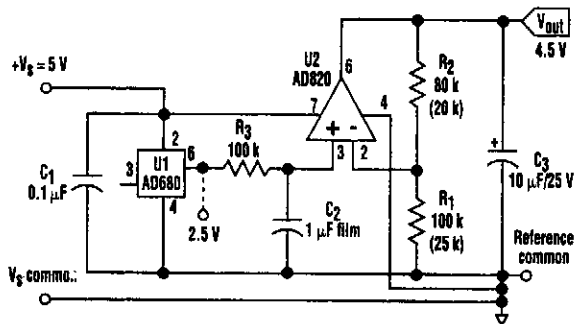

ELECTRONIC DESIGN

Fig. 68-15

This low-dropout reference produces a 4.5-V output from a supply just a few hundred millivolts greater. With 1-mA dc loading, it maintains a stable 4.5-V output for inputs down to 4.7 V.

SCR SWITCHING SUPPLY FOR COLOR TV RECEIVERS

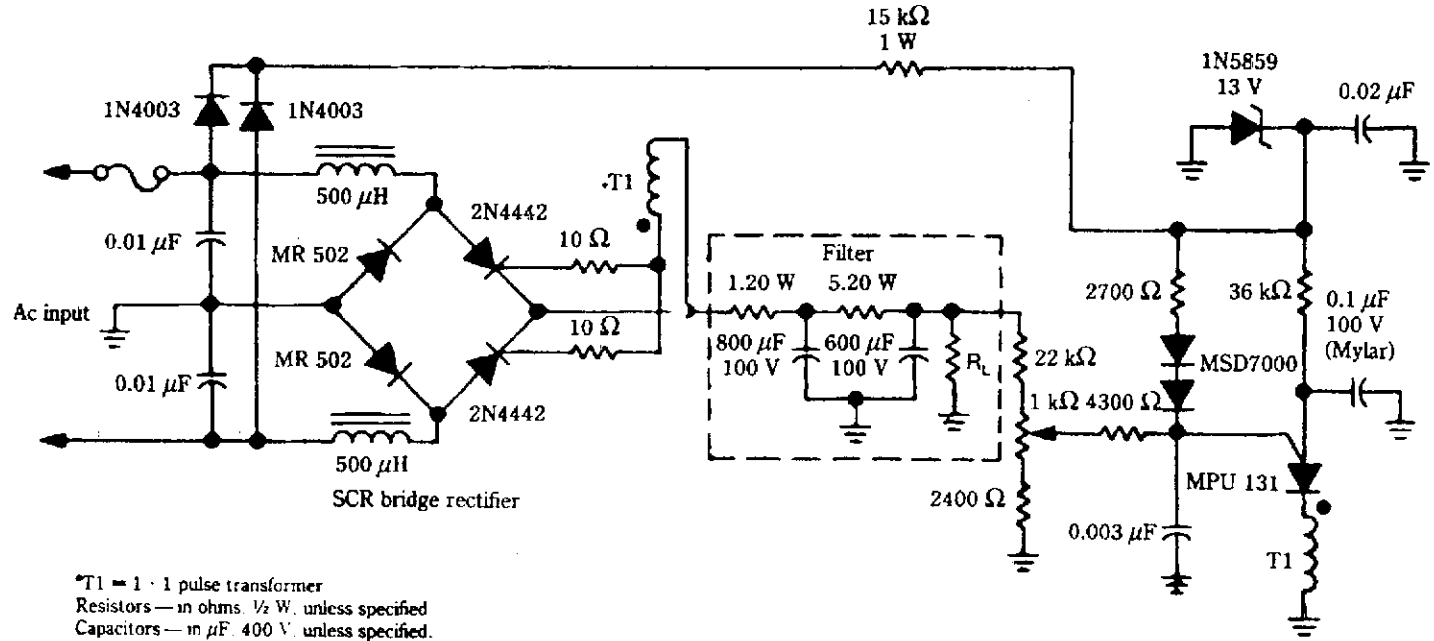

McGRAW-HILL

Fig. 68-16

An output +80 V at up to 1.5 A is available from this supply. A minimum load of 200 mA is required because of the SCR holding current. Notice that no ac line isolation is provided and a shock hazard exists.

REGULATOR CIRCUIT FOR BILATERAL SOURCE/LOAD POWER SYSTEM

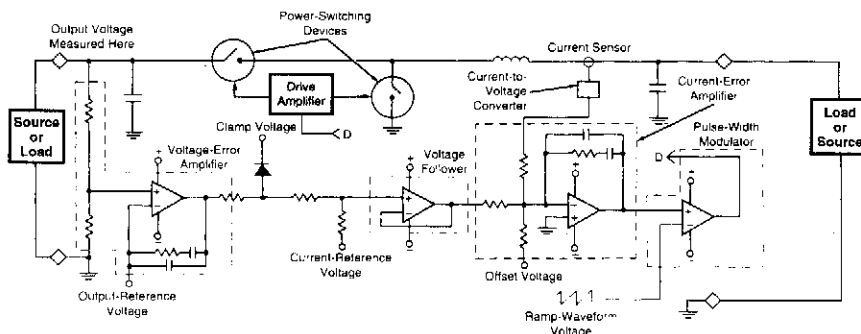

NASA TECH BRIEFS

Fig. 68-17

The figure shows a circuit that regulates an output voltage, regardless of the direction of flow of output current. More specifically, it regulates the voltage at the left source or load, which can either supply power to or receive power from the right load or source, depending on the voltages and the direction of flow of current at the load/source terminals.

The overall system can be characterized as a voltage-controlled current source with bilateral current capability. The current flowing between the two source/loads, averaged over a power-switching cycle, is made to depend on the pulse-width modulation that governs the operation of the two power-switching devices, and this pulse-width modulation is, in turn, a function of amplified current-error and voltage-error signals. The voltage error is the difference between the actual output voltage and the output-reference voltage, which is the nominal output voltage at zero current. The pulse-width modulation is varied to increase or decrease the current, as needed, to limit the excursion of output voltage from the reference value.

An additional feature of this control circuit is that the maximum current in either direction can be limited by limiting the excursion of the output voltage from the zero-current value. Thus, external current-limiting circuitry is not necessary.

FAST 3.3-V ADJUSTABLE REGULATOR

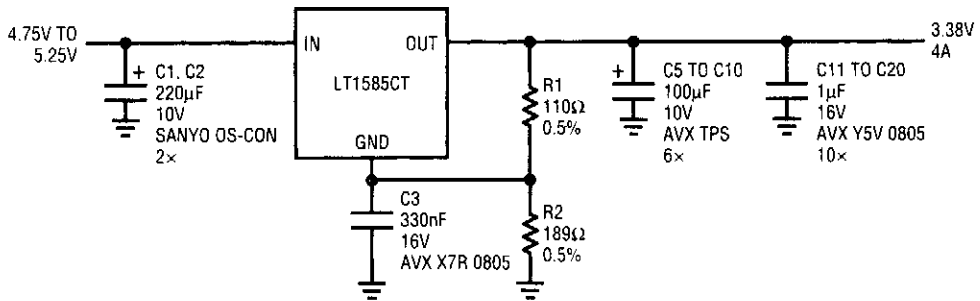

LINEAR TECHNOLOGY

Fig. 68-18

The adjustable version of the LT1585 makes it relatively easy to accommodate multiple microprocessor power-supply voltage specifications. To retain the tight tolerance of the LT1585 internal reference, a 0.5% resistor adjustment is recommended. R1 is sized to carry approximately 10 mA idling current ($\leq 124 \Omega$), and R2 is calculated from:

$$R_2 = \frac{V_o - V_{ref}}{\frac{V_{ref}}{R_1} + I_{ADM}}$$

where:

$$I_{ADM} = 60 \mu \text{ and } V_{ref} = 1.250 \text{ V.}$$

TWO-TERMINAL 100-mA CURRENT REGULATOR

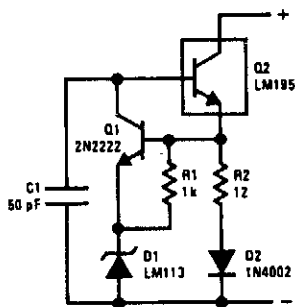

NATIONAL SEMICONDUCTOR

Fig. 68-19

The circuit has a low temperature coefficient and operates down to 3 V. The reverse base current of the LM195 biases the circuit.

A 2N2222 is used to control the voltage across current-sensing resistor, R2 and diode D1, and therefore the current through it. The voltage across the sense network is the V_{BE} of the 2N2222 plus 1.2 V from the LM113. In the sense network, R2 sets the current and D1 compensates for the V_{BE} of the transistor. Resistor R1 sets the current through the LM113 to 0.6 mA.

TWO-PHASE RECTIFIER

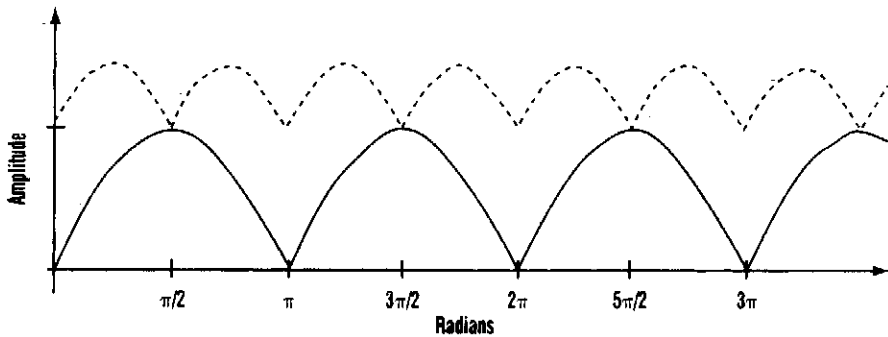
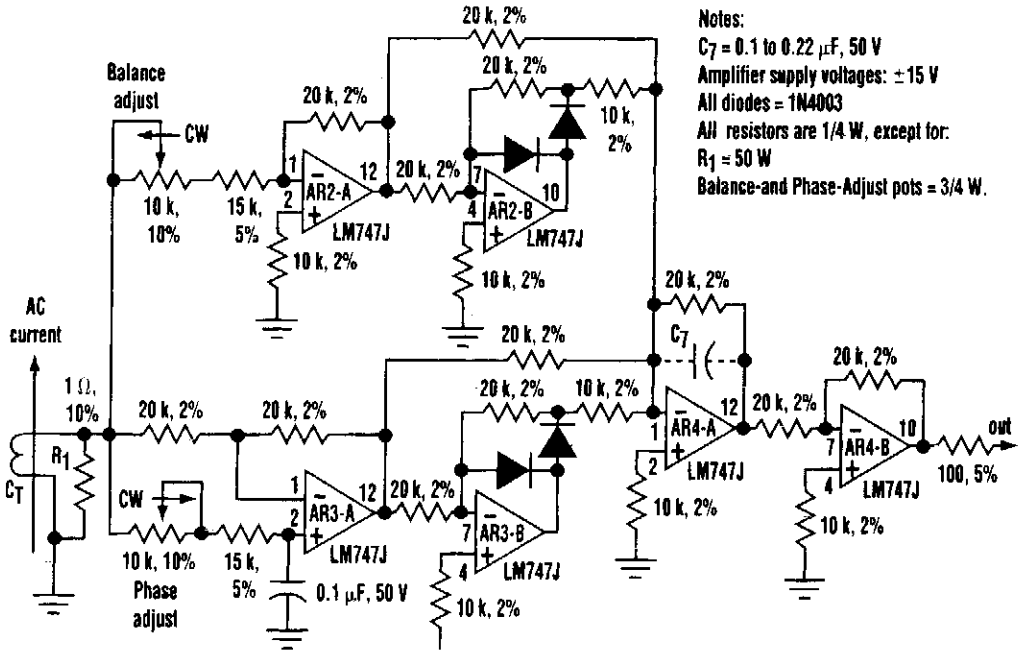

A single-phase AC signal can be converted to two phase with this circuit. It rectifies and sums the signal to a dc voltage level.

The waveform generated by the two-phase rectifier illustrates that the ripple is less than half that of a conventional single-phase circuit's waveform. Also, the ripple frequency is double that of the conventional circuit. The circuit will follow amplitude changes in the ac input signal very rapidly, and it works equally well with current or voltage inputs.

LOW-NOISE 5-V SUPPLY

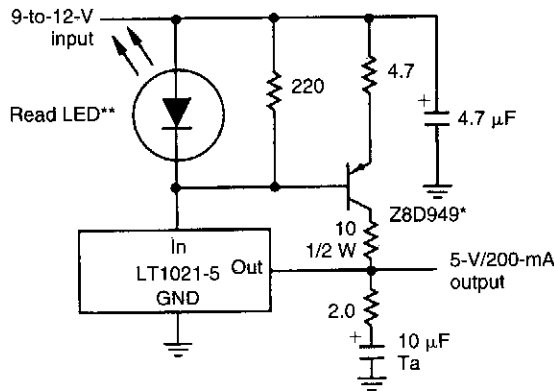

*Zetex Inc.

**Glows in current limit. Do not omit.

ELECTRONIC DESIGN

Fig. 68-21

Standard three-terminal regulator ICs can be noisy. The key is the noise over the 10-Hz to 10-kHz band; measurements revealed a 40-dB improvement over standard three-terminal regulators.

The regulator is built around a 5-V buried-Zener reference. It's the buried Zener's inherently low noise that makes the finished supply so quiet. Measured over a 10-Hz to 10-kHz band, the 5-V output contains just 7 μV rms of noise at full load. The 10-Hz to 10-kHz noise can be further reduced to 2.5 μV rms by adding a 100- μH , 1000- μF output filter. The noise characteristics of the reference are tested and guaranteed to a maximum of 11 μV over the band of interest.

An external boost transistor, the ZBD949, provides gain to meet a 200-mA output current requirement. Current limiting is achieved by ballasting the pass transistor and clamping the base drive. Although the oscillator only requires 200 mA, it's possible to extend the output current to at least 1 A.

POSITIVE REGULATOR WITH 0- TO 70-V OUTPUT

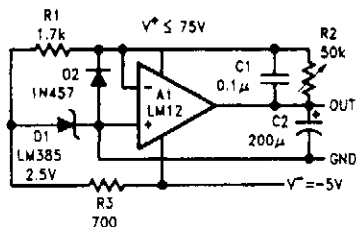

The op amp has one input at ground and a reference current drawn from its summing junction. With this arrangement, the output voltage is proportional to setting resistor R2. A negative supply is used to operate the op amp within its common-mode range, providing zero output with sink current and power a low-voltage bandgap reference, D1. The current drawn from this supply is under 150 mA, except when sinking a load current. The output load capacitor, C2, is part of the op-amp frequency compensation.

NATIONAL SEMICONDUCTOR

Fig. 68-22

SIMPLE 12-V POWER SUPPLY

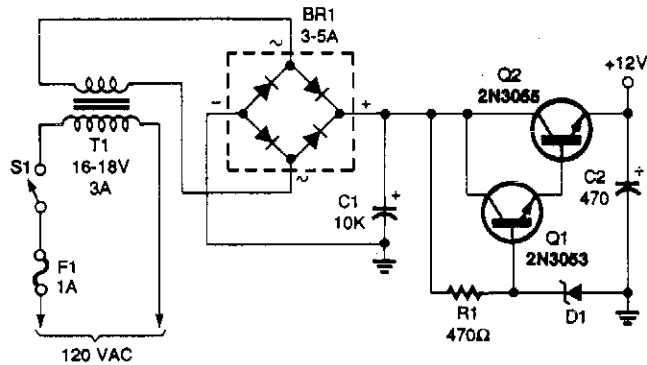

POPULAR ELECTRONICS

Fig. 68-23

This 12-V power supply is easy-to-build, and it produces a smooth output. D1 is a 14-V, $\frac{1}{2}$ -W Zener diode. The voltage can be varied by a few volts up or down to change the output voltage.

3.3 V FROM 5-V LOGIC SUPPLIES

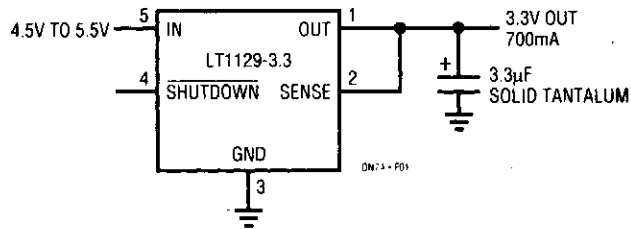

LINEAR TECHNOLOGY

Fig. 68-24

Microprocessor chip sets and logic families that operate from 3.3-V supplies are gaining acceptance in both desktop and portable computers. Computing rates, and in most cases, the energy consumed by these circuits, show a strong improvement over 5-V technology. The main power supply in most systems is still 5 V, necessitating a local 5-V to 3.3-V regulator. Linear regulators are viable solutions at lower ($I_o \leq 1$ A) currents, but they must have a low dropout voltage in order to maintain regulation with a worst-case input of only 4.5 V. The figure shows a circuit that converts a 4.5-V minimum input to 3.3 V with an output tolerance of only 3% (100 mV). The LT1129-3.3 can handle up to 700 mA in surface-mount configurations, including both 16- μ A shutdown and 50- μ A standby currents for system sleep modes. Unlike other linear regulators, the LT1129-3.3 combines both low-dropout and low-voltage operation. Small input and output capacitors facilitate compact, surface-mount designs.

12-V SUPPLY

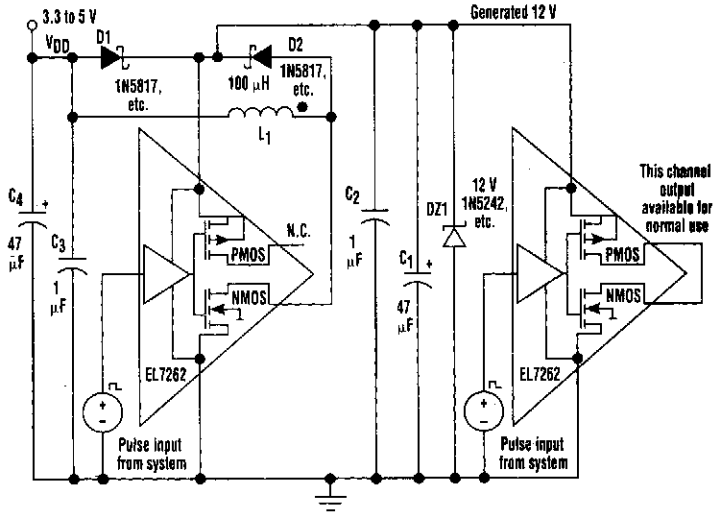

Fig. 68-25

ELECTRONIC DESIGN

When driving a power MOSFET from a 5-V or 3.3-V system, a significant number of components usually are needed to generate an extra +12 V.

It's possible, however, to apply the second channel in a typical dual MOSFET driver to derive a +12-V power supply. By using a driver with the drains brought to separated pins, you can connect an inductor between the n-channel drain and the logic supply without connecting the p-channel device.

The driver operates as a standard flyback-style switched-mode circuit (see the figure). When the output n-channel device is on, current starts flowing in the inductor, which stores energy. When the n-channel device is turned off, current must continue flowing. Therefore, it flows through diode D2 to charge up C1 and C2. As the cycle repeats, the C1 and C2 voltage rises until the Zener diode prevents further voltage rise. This is needed to prevent the driver's derived supply from exceeding the part's maximum voltage rating.

4- TO 70-V REGULATOR

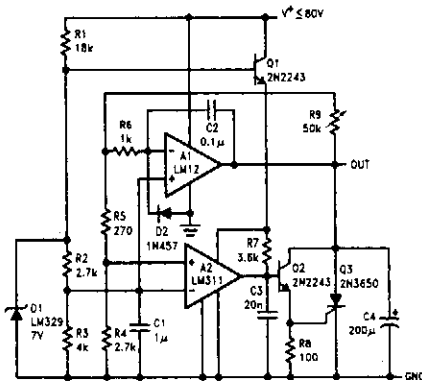

This regulator operates from a single supply. If the op amp is not able to control an overvoltage condition, the SCR will crowbar the output.

Fig. 68-26

SWITCHED POWER-CONTROL CIRCUITS

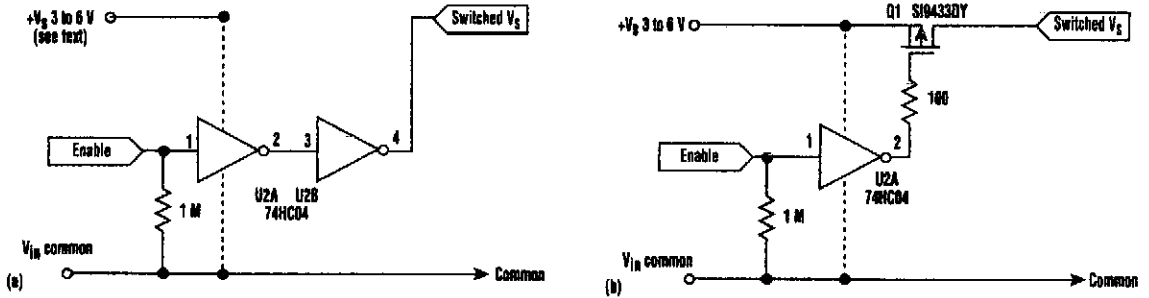

ELECTRONICS DESIGN

Fig. 68-27

Load currents of a few milliamperes to amperes can be turned on and off by these switched power-control circuits. The U2 CMOS inverter stage works as a simple power switch for load currents less than 5 mA (Fig. 68-27A), allowing easy reference shutdown. If appreciably higher switched output currents are called upon, an alternate CMOS inverter driving a low-threshold PMOS device can be used to switch currents of up to 1 A or more (Fig. 68-27B).

MULTIPLE ON-CARD REGULATOR ADJUSTER

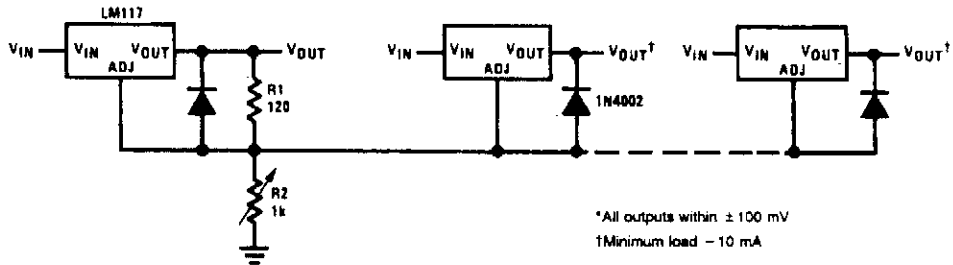

NATIONAL SEMICONDUCTOR

Fig. 68-28

This circuit allows one pot to control several on-card regulators for adjustment within ± 100 mV of each other.

SIMPLE 9-V POWER SUPPLY

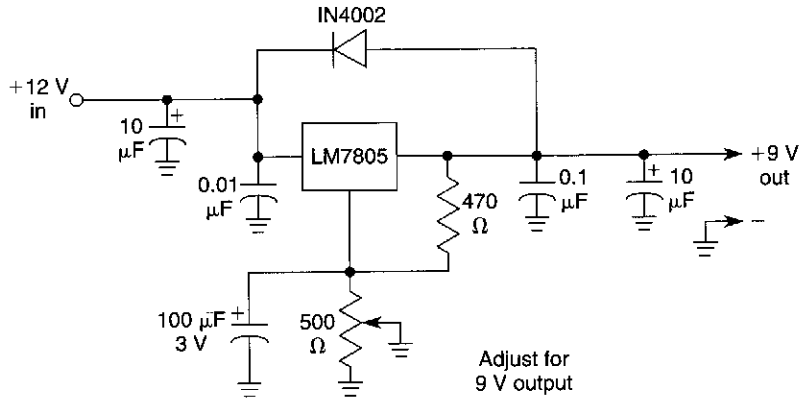

WILLIAM SHEETS

Fig. 68-29

This supply will provide 9-V transistor radios or cassettes from a 12-V auto electrical system.

+5-V AT 1-A SUPPLY WITH +3- TO +5-V INPUT

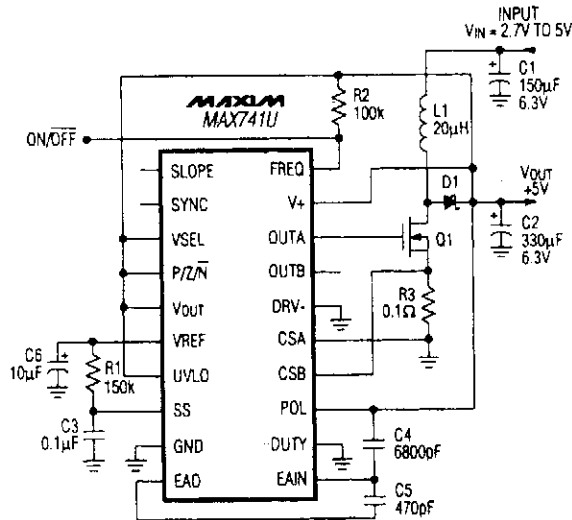

MAXIM

Fig. 68-30

A MAX741U switching-mode power-supply controller and a switching FET Q1 are used to provide +5 V at 1 A.

5-Vdc REGULATED SUPPLY

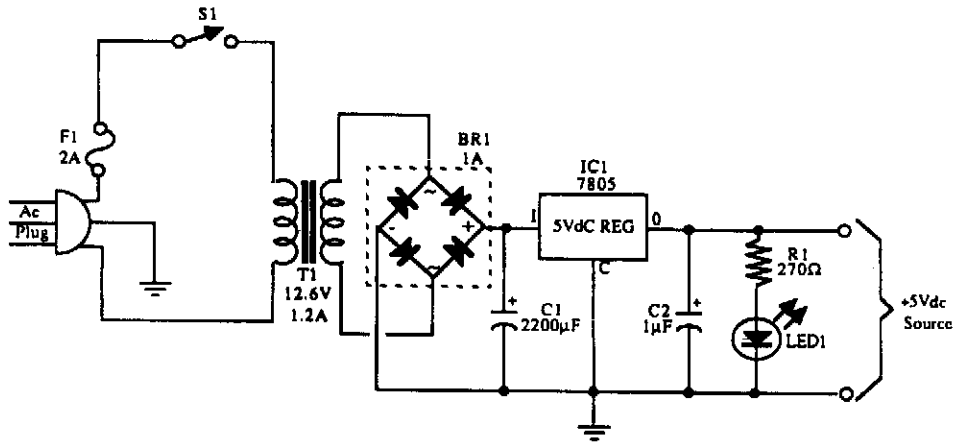

McGRAW-HILL

Fig. 68-31

BUFFERED REFERENCE SUPPLY

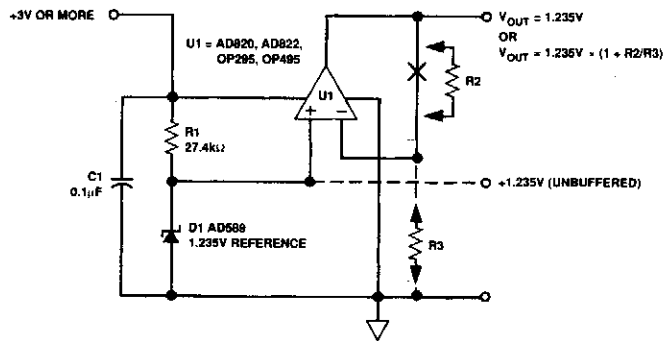

ANALOG DEVICES

Fig. 68-32

This buffered reference (for 1.23 V or more) uses a supply voltage of greater than 3 V.

5-V LOGIC REGULATOR WITH ELECTRONIC SHUTDOWN

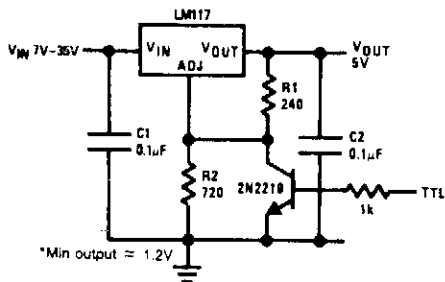

The circuit will shut down to 1.2 V under fault conditions.

NATIONAL SEMICONDUCTOR

Fig. 68-33

12-Vdc REGULATED SUPPLY

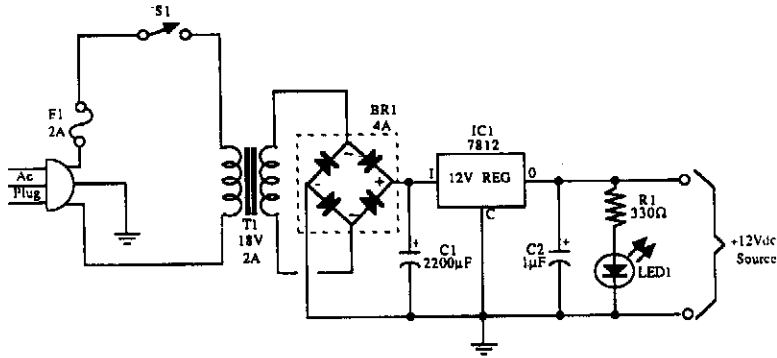

McGRAW-HILL

Fig. 68-34

JUNKED TRANSISTOR REGULATORS

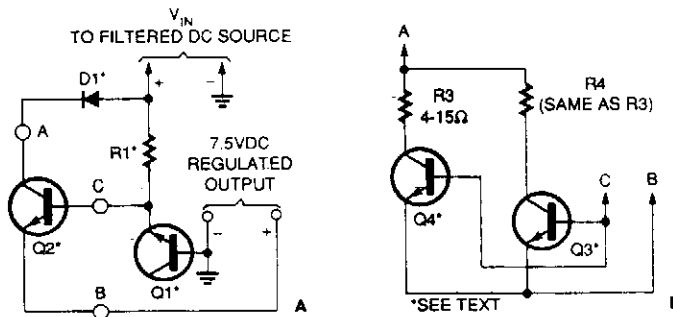

POPULAR ELECTRONICS

Fig. 68-35

Old transistors can make excellent regulators. Simply use one as a Zener to control the base current to another transistor (Fig. 68-35A). If the pass transistor cannot supply enough current, you can use two pass transistors in its place (Fig. 68-35B).

TELEPRINTER LOOP SUPPLY

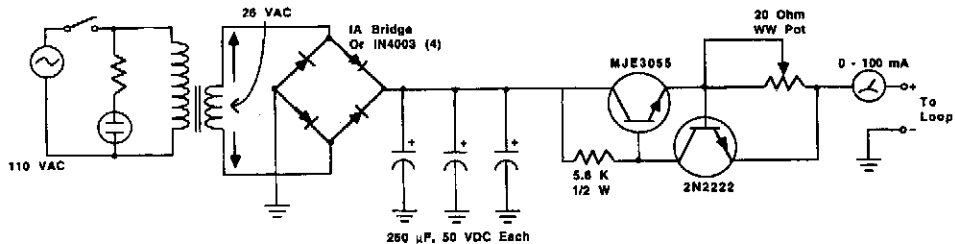

73 AMATEUR RADIO TODAY

Fig. 68-36

A circuit to power a teleprinter, using transistors as current-controlling devices. The power supply used provides a constant current in a loop, normally 60 mA or 20 mA, depending on the machine.

5-A CONSTANT-VOLTAGE SUPPLY

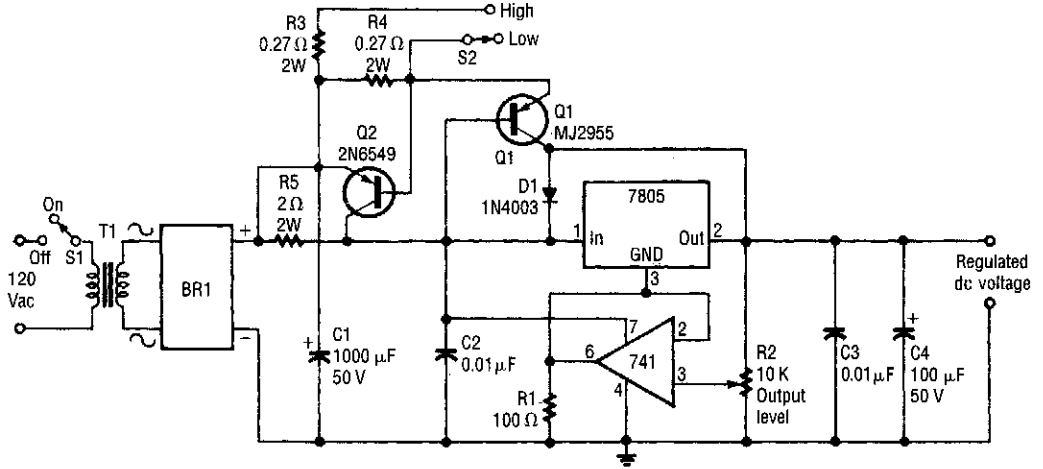

ELECTRONICS NOW

Fig. 68-37

This constant-voltage supply has a variable output. It can supply more than 5 A, and has two switchable current limits.

69

Power Supply Circuits (High Voltage)

The sources of the following circuits are contained in the Sources section, which begins on page 707. The figure number in the box of each circuit correlates to the entry in the Sources section.

Fluorescent Lamp 12-V Supply
High-Voltage Regulator
Night-Vision Scope Power Supply
High-Voltage Power-Supply Control Circuit
-100-Vdc Supply
ac-Operated He-Ne Power Supply
HV Regulator with Foldback Current Limit
Kirlian Device Supply
High-Voltage Tripler
200-V Regulator
Pulse-Width Modulated Laser Supply

FLUORESCENT LAMP 12-V SUPPLY

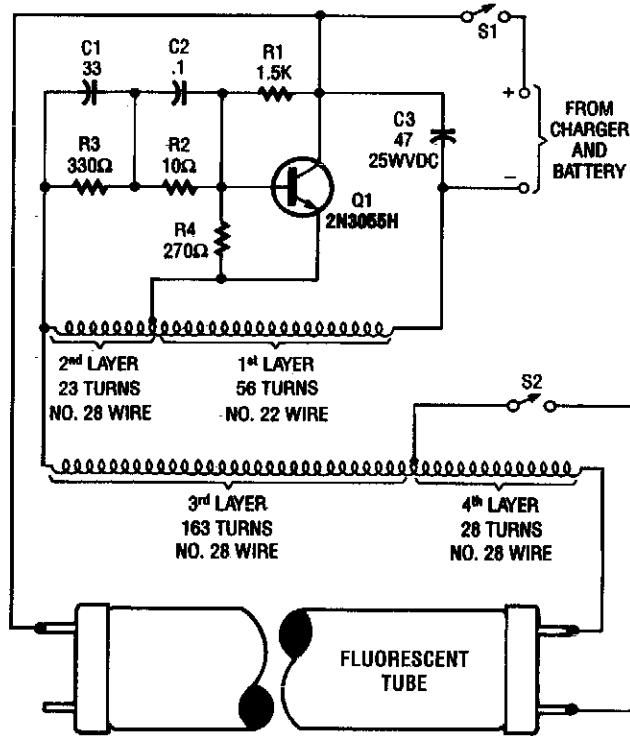

POPULAR ELECTRONICS

Fig. 69-1

This high-voltage power supply can operate fluorescent tubes from a 12-V source, even if the tube has a defective filament. It essentially is an oscillator that excites a home-made autotransformer. T1 is wound on a ferrite rod $\frac{3}{8}$ " diameter by $1\frac{1}{2}$ " long, in layers. S2 is an optional lamp filament switch.

HIGH-VOLTAGE REGULATOR

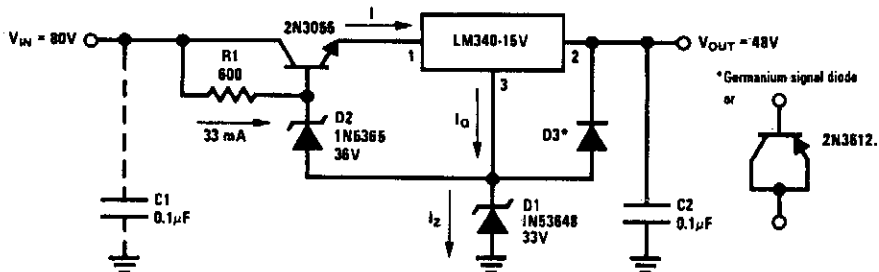

NATIONAL SEMICONDUCTOR

Fig. 69-2

This circuit produces 48 V from an 80-V input.

-100-Vdc SUPPLY

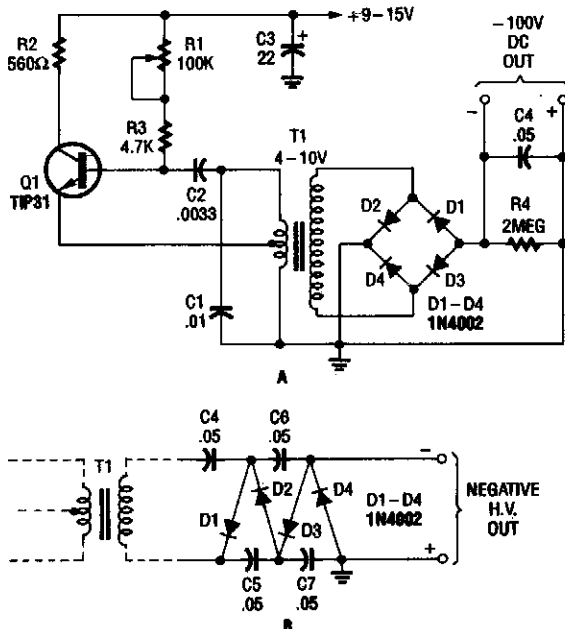

POPULAR ELECTRONICS

Fig. 69-5

The combination Hartley oscillator/step-up transformer shown in A can generate significant negative high-voltage—especially if the voltage output of the transformer is multiplied by the circuit in Fig. 69-5B. T1 is a small low-voltage filament transformer of around 4- to 10-Vac output, 120-V primary.

ac-OPERATED HE-NE POWER SUPPLY

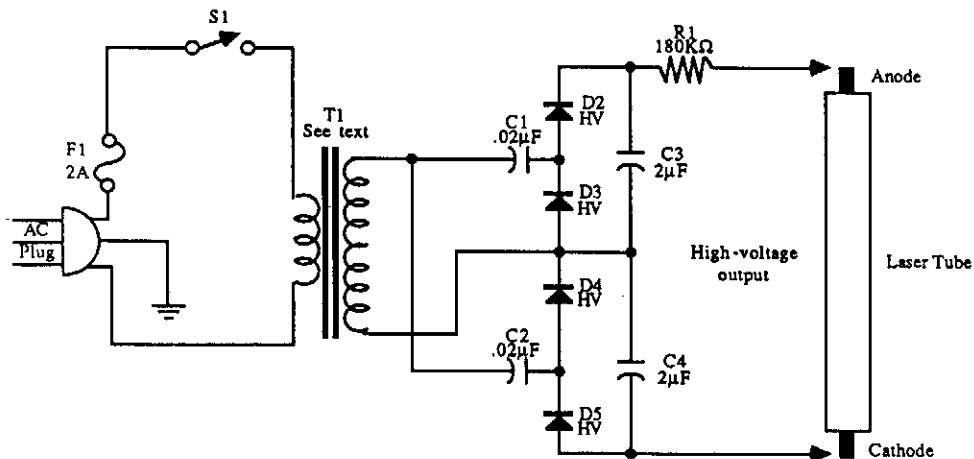

McGRAW-HILL

Fig. 69-6

T1 is a 120-V to 1000-V step-up 60-Hz transformer. C1, C2, C3, C4 and D2 through D5 form a voltage quadrupler. The initial voltage is 4 to 5 kV, which drops when the laser tube fires.

HV REGULATOR WITH FOLDBACK CURRENT LIMIT

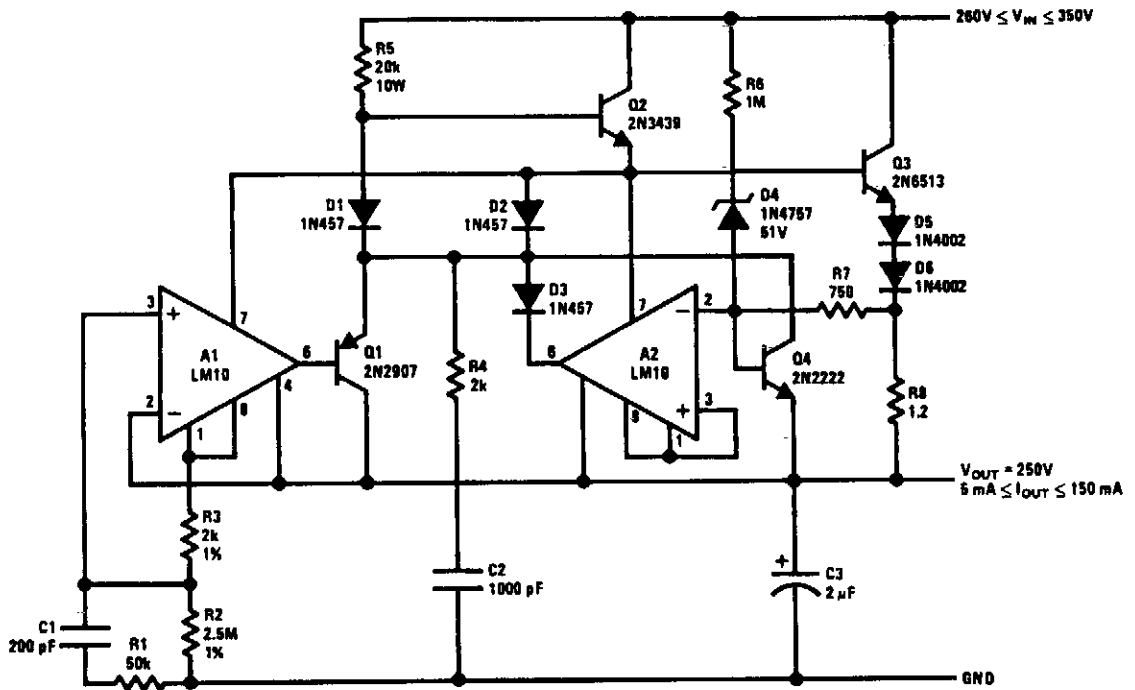

NATIONAL SEMICONDUCTOR

Fig. 69-7

The output current is sensed across R8. This is delivered to the current-limit amplifier through R7, across which the foldback potential is developed by R6 with a threshold determined by D4. The values given limit the peak power below 20 W and shut off the pass transistors when the voltage across them exceeds 310 V. With unregulated input voltages above this value, start-up is initiated solely by the current through R5. Q4 is added to provide some control on current before A2 has time to react.

The circuit is stable with an output capacitor greater than about 2 μ F. Spurious oscillations in current limit are suppressed by C2 and R4, while a strange, latch-mode oscillation coming out of current limit is killed with C1 and R1.

KIRLIAN DEVICE SUPPLY

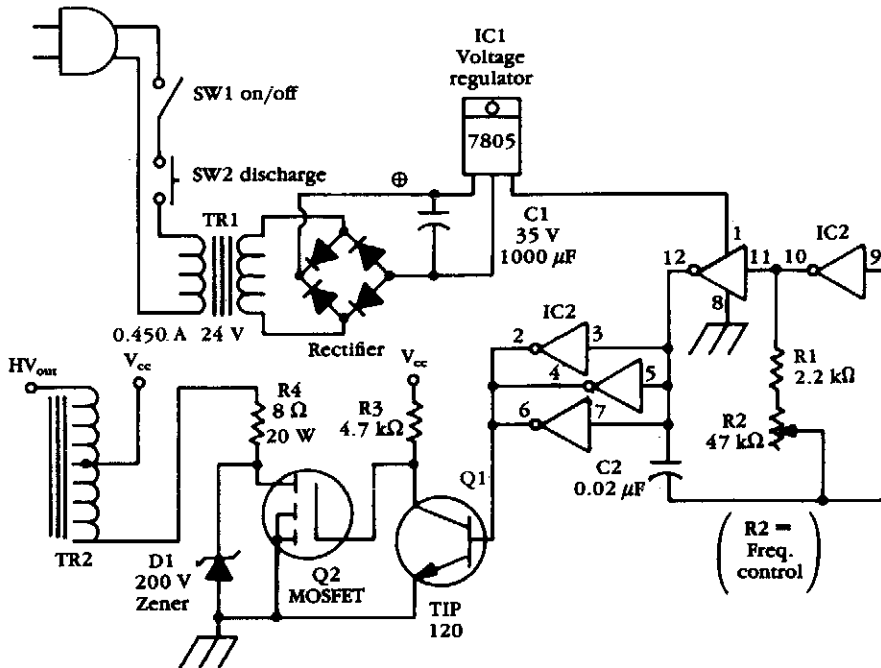

McGRAW-HILL

Fig. 69-8

This device is essentially a high-voltage variable-frequency ac supply. A CD4049 IC multivibrator circuit drives a Darlington connected transistor pair, which drives TR2, an HV transformer.

HIGH-VOLTAGE TRIPLER

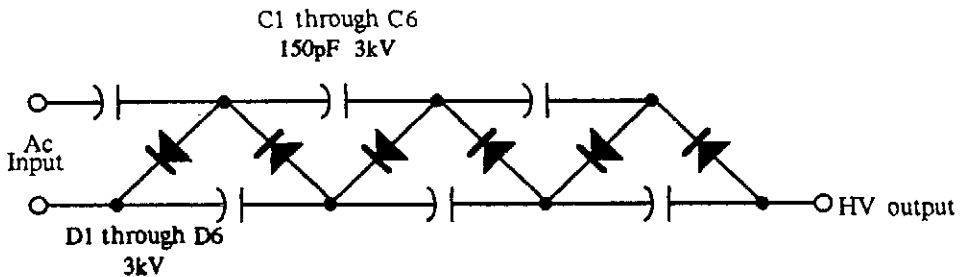

McGRAW-HILL

Fig. 69-9

This tripler is useful for low-current and high-voltage applications. The capacitors can be 0.001- μ F, 3- to 6-kV discs, and the diode's 3-kV units, or three each IN4007 in series.

200-V REGULATOR

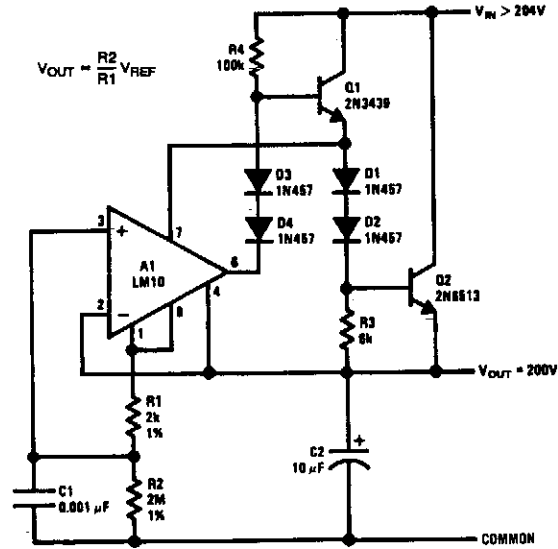

NATIONAL SEMICONDUCTOR

Fig. 69-10

With high-voltage regulators, powering on the IC through the drive resistor for the pass transistors can become quite inefficient. This is avoided with the circuit shown. The supply current for the IC is derived from Q1. This allows R4 to be increased by an order of magnitude without affecting the dropout voltage.

Selection of the output transistors will depend on voltage requirements. For output voltages above 200 V, it might be more economical to cascade lower-voltage transistors.

PULSE-WIDTH MODULATED LASER SUPPLY

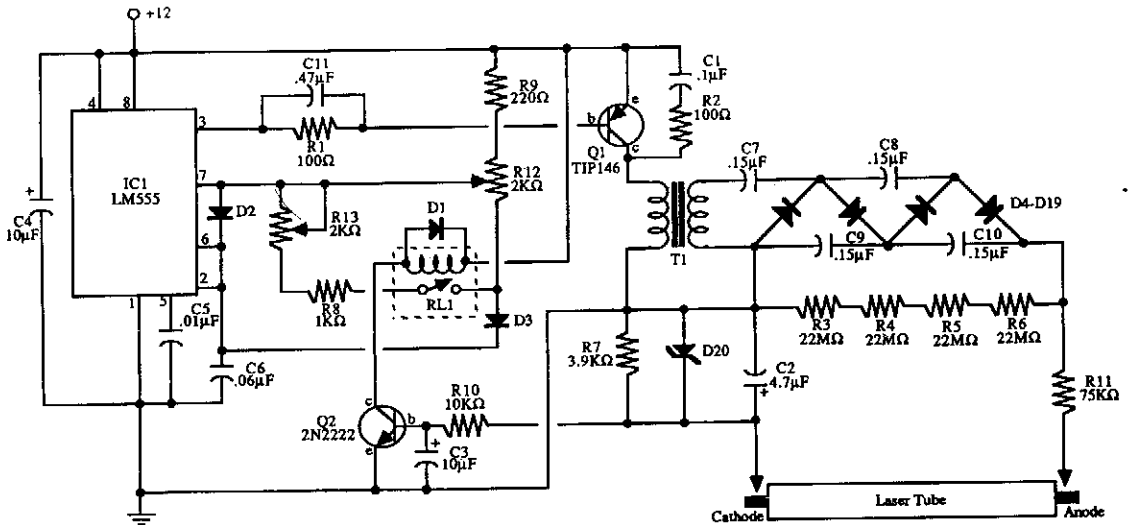

McGRAW-HILL

Fig. 69-11

IC1 initially provides drive for Q1 and HV transformer T1, and it rectifies D4 through D19. When the laser tube ignites, Q2 is triggered; this activates relay RL1, reducing the duty cycle. R13 controls the duty cycle of the pulses through the laser tube.

70

Power Supply Circuits (Multiple Output)

The sources of the following circuits are contained in the Sources section, which begins on page 706. The figure number in the box of each circuit correlates to the entry in the Sources section.

Experimenter's Power Supply
Quad Power Supply
Activate Back-Up Power Supply
CCFL Supply with Variable Contrast
dc Power Source for Experiments
Stable VFO Power Supply
High-Efficiency Triple-Output Supply for Notebook Computers
General-Purpose Power Supply for Automotive Projects
 ± 15 -V Power Supply

EXPERIMENTER'S POWER SUPPLY

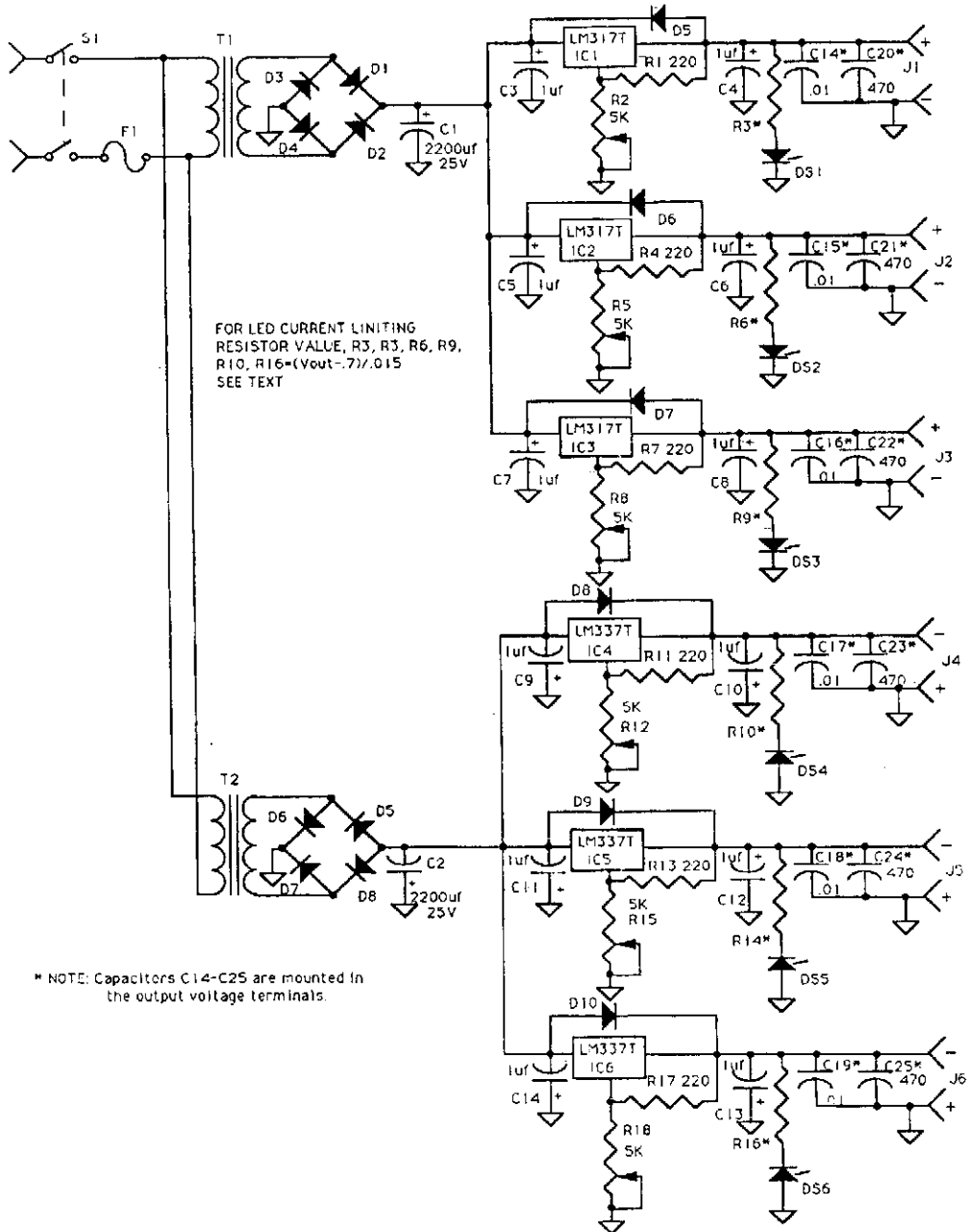

73 AMATEUR RADIO TODAY

Fig. 70-1

Passive linear IC regulators are used to make up a supply delivering +12, +9, +5, -5, -9, and -12 Vdc. T1 and T2 are 12-V, 3-A transformers.

QUAD POWER SUPPLY

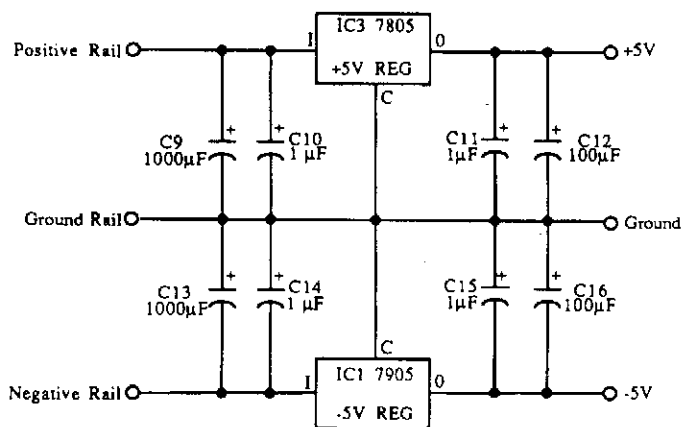
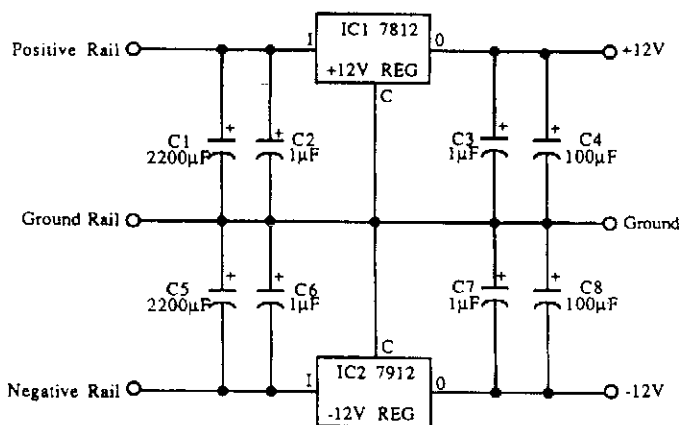
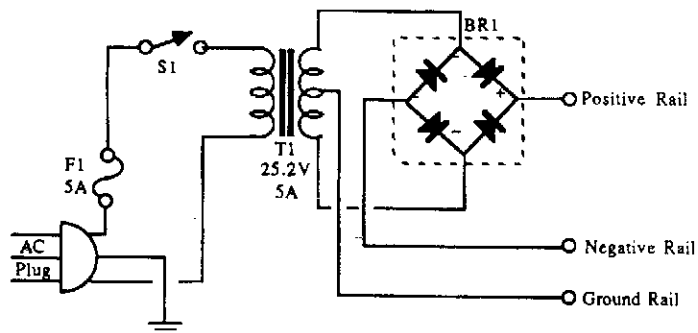

ACTIVATE BACK-UP POWER SUPPLY

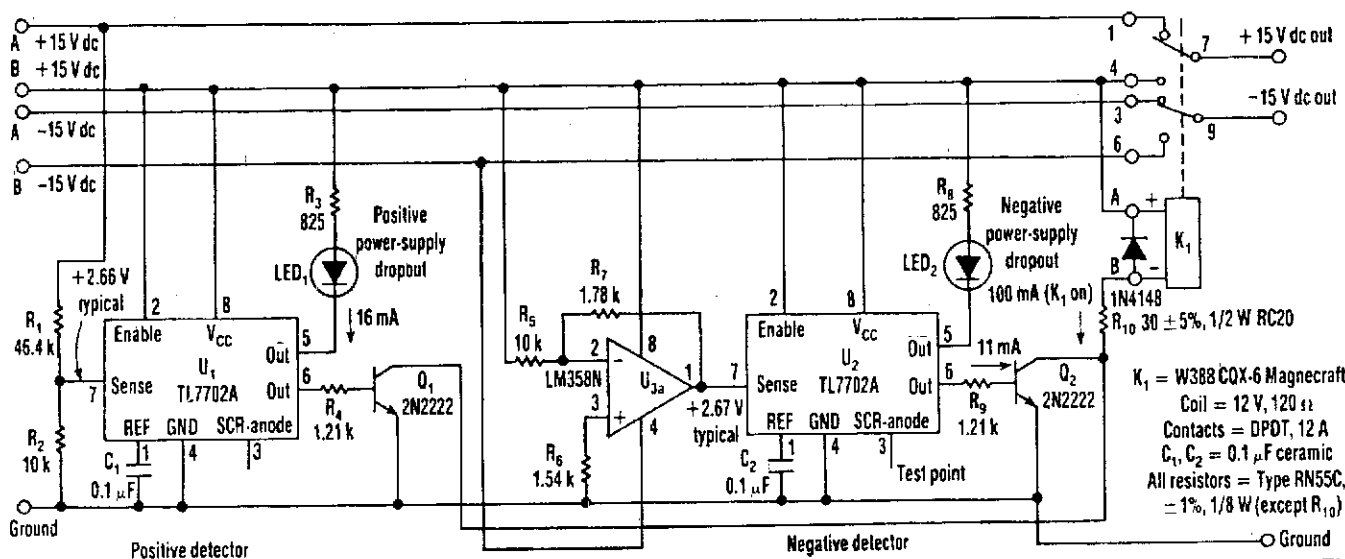

$K_1 =$ W388 CQX-6 Magnecraft
Coil = 12 V, 120 Ω
Contacts = DPDT, 12 A
 $C_1, C_2 = 0.1 \mu\text{F}$ ceramic
All resistors = Type RN55C,
 $\pm 1\%$, 1/8 W (except R_{10})

Fig. 70-3

ELECTRONIC DESIGN

A circuit, which can be built around two TI TL7702 chips, monitors a 15-V power supply and activates a relay to turn on a back-up supply if the voltage drops below ± 14.1 V. With the back-up in place, the malfunctioning supply can be replaced without any down time. The TL7702 power-supply voltage supervisor chips are intended for use as reset controllers in microprocessor systems, but they work well in their modified form for this application.

One chip detects the positive supply (U1), and the other is used for the negative (U2). A pair of output-relay drive transistors, Q1 and Q2, form a wired OR circuit so that relay K1 is activated by the positive or negative voltage detector that switches U1 or U2 on.

The supervisor chips have a direct connection to the input comparator so that the trigger level is set by a resistor-divider network (R1 and R2) at the sense-input pin. These chips also have an internal, stable, reference-voltage source set at +2.53 V, typical. The positive-sensed voltage drops enough to activate the comparator, its output goes low, switches the internal gate, and triggers the silicon-controlled rectifier (SCR). The output comparator then forces the two output transistors to switch, one high and one low. The output transistor (pin 5) turns on the light-emitting diode (LED), and the output transistor (pin 6) turns on the relay driver, Q1.

The negative detector is preceded by half of the dual op amp LM358N (U3a)—an inverting amplifier with a gain of -0.178 . R5 connects to the -15 Vdc being sensed. The output of U3a is usually set at 2.67 V, higher than the +2.53-V reference voltage. Therefore, no switching occurs. If the -15 -Vdc voltage decreases, U2 switches Q2 and activates K1 in the same manner as described for the U1-Q1 positive detector. R3, R4, and R8 through R10 serve as current-limiting resistors.

CCFL SUPPLY WITH VARIABLE CONTRAST

ALUMINUM ELECTROLYTIC IS RECOMMENDED FOR C3B WITH AN ESR $\geq 0.5\Omega$ TO PREVENT DAMAGE TO THE LT1182 HIGH-SIDE SENSE RESISTOR DUE TO SURGE CURRENTS AT TURN-ON.

C1 MUST BE A LOW LOSS CAPACITOR, C1 - WIMA MKP-20

Q1, Q2 = ZETEX ZTX849 OR ROHM 2SC5001

L1 = COILTRONICS CTX210605

L2 = COILTRONICS CTX100-4

L3 = COILTRONICS CTX02-12403

***DO NOT SUBSTITUTE COMPONENTS**

COILTRONICS (407) 241-7876

0µA TO 45µA ICCFL CURRENT GIVES
0mA TO 6mA BULB CURRENT.
THIS IS EQUAL TO
0% TO 90% DUTY
CYCLE FOR THE
PWM SIGNAL.

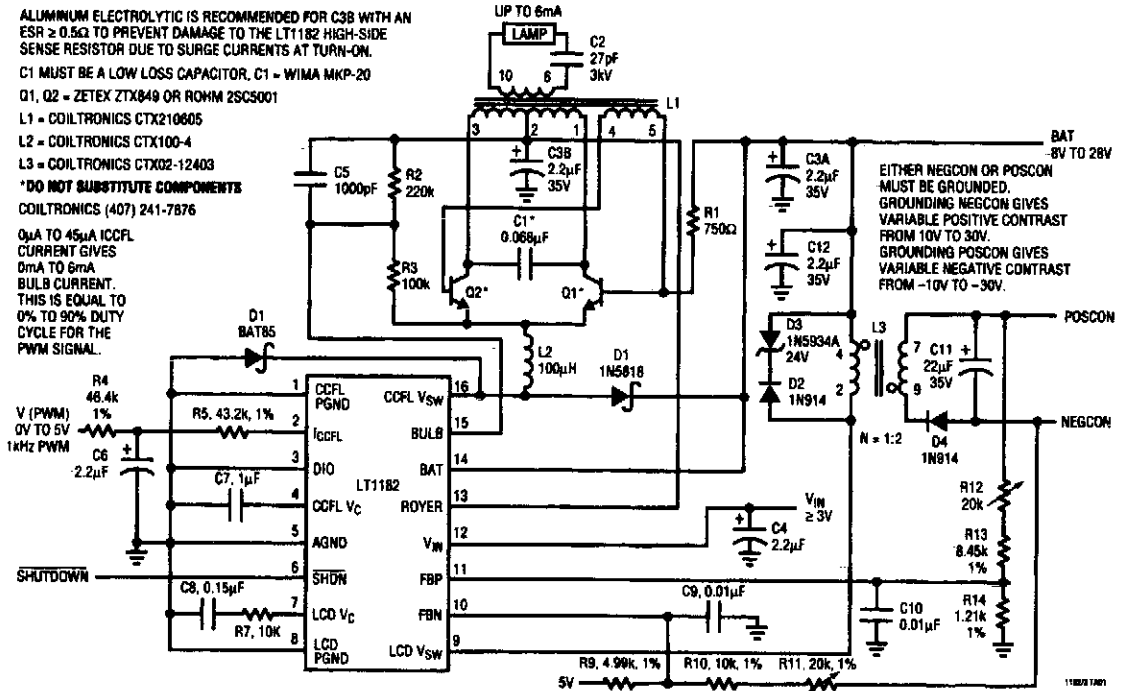

LINEAR TECHNOLOGY

Fig. 70-4

The figure is a complete floating CCFL circuit with variable negative/variable positive-contrast voltage capability, based on the LT1182. Lamp current is programmable from 0 mA to 6 mA using a 0- to 5-V 1-kHz PWM signal at 0% to 90% duty cycle. LCD contrast output voltage polarity is determined by which side of the transformer secondary (either POSCON or NEGCON) the output connector grounds. In either case, LCD contrast output voltage is variable from an absolute value of 10 V to 30 V. The input supply voltage range is 8 V to 28 V. The CCFL converter is optimized for photometric output per watt of input power. CCFL electrical efficiency up to 90% is possible and requires strict attention to detail. LCD contrast efficiency is 82% at full power.

dc POWER SOURCE FOR EXPERIMENTS

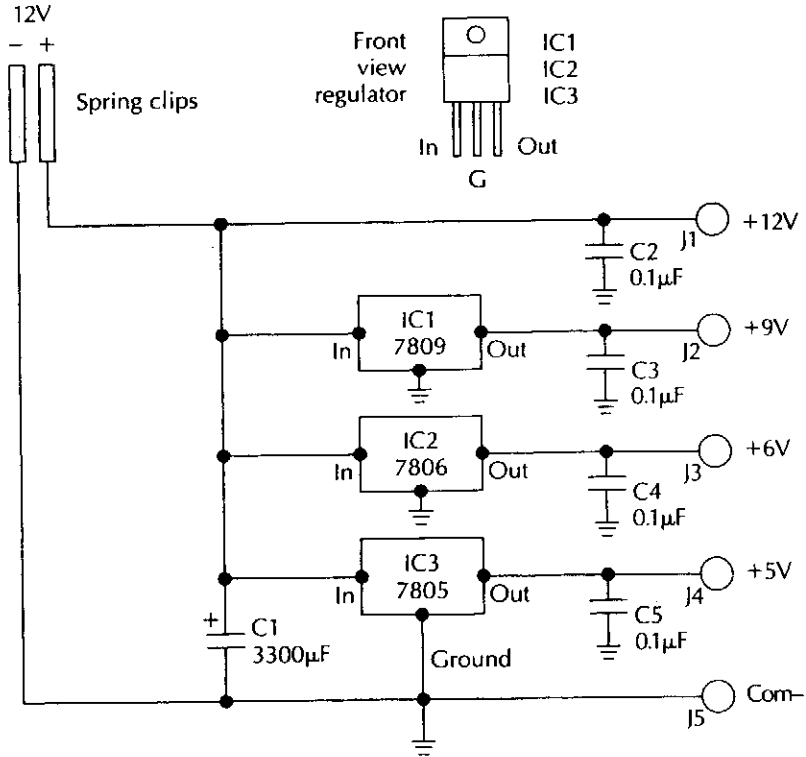

McGRAW-HILL

Fig. 70-5

This supply uses IC regulators to supply +5, +6, +9, and +12 volts regulated from a nominal 12-V supply.

STABLE VFO POWER SUPPLY

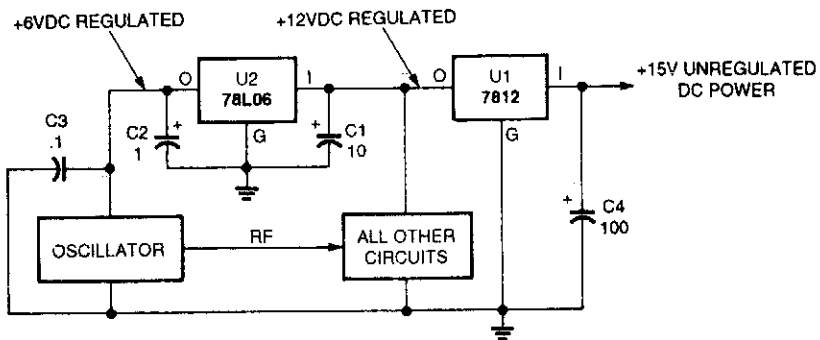

POPULAR ELECTRONICS

Fig. 70-6

A dc power-distribution system for a stable oscillator should use a separate voltage regulator just for the oscillator circuit.

HIGH-EFFICIENCY TRIPLE-OUTPUT SUPPLY FOR NOTEBOOK COMPUTERS

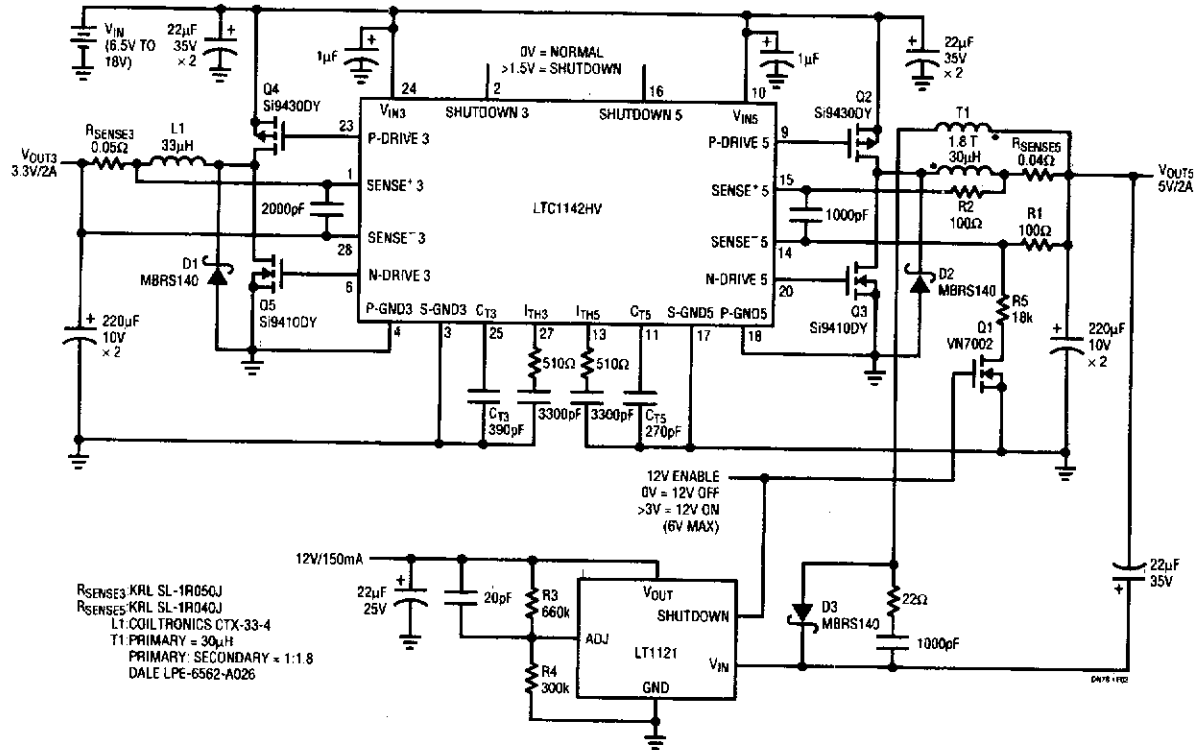

LINEAR TECHNOLOGY

Fig. 70-7

The circuit is configured to provide output voltages of 3.3 V, 5 V, and 12 V. The current capability of both the 3.3-V and 5-V outputs is 2 A (2.5 A peak). The logic controlled 12-V output can provide 150 mA (200 mA peak), which is ideal for flash memory applications. The operating efficiency shown in the figure exceeds 90% for both the 3.3-V and 5-V sections.

The 3.3-V section for the circuit in the figure is comprised of the main switch Q4, synchronous switch Q5, inductor L1, and current shunt R_{SENSE} . Current-sense resistor R_{SENSE} monitors the inductor current and is used to set the output current according to the formula $OUT = 100 \text{ mV}/R_{SENSE}$. Advantages of current control include excellent line and load transient rejection, inherent short-circuit protection, and controlled start-up currents. Peak inductor currents for L1 and T1 for the circuit in the figure are limited to $150 \text{ mV}/R_{SENSE}$ or 3.0 A and 3.75 A, respectively.

GENERAL-PURPOSE POWER SUPPLY FOR AUTOMOTIVE PROJECTS

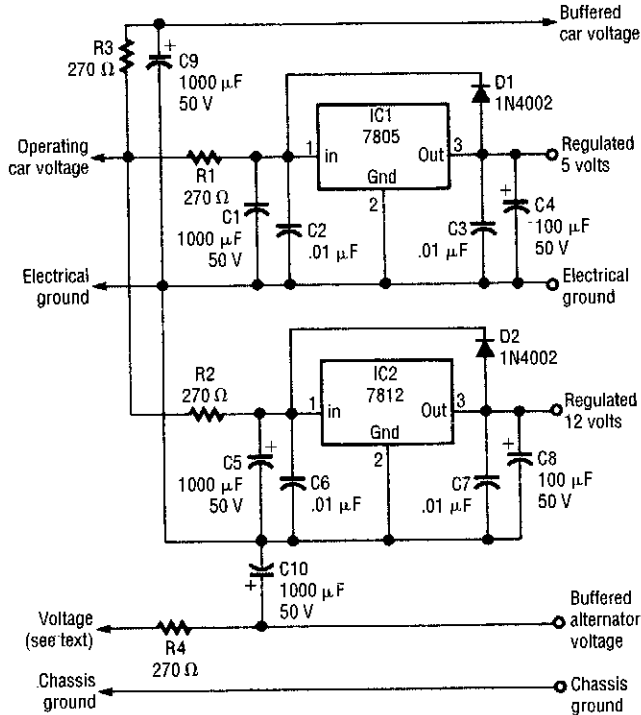

Fig. 70-8

ELECTRONICS NOW

This supply produces 12 V and 5 V for a variety of automotive projects. F4 is connected directly to the alternator field winding (usable only if your car has a separate regulator).

±15-V POWER SUPPLY

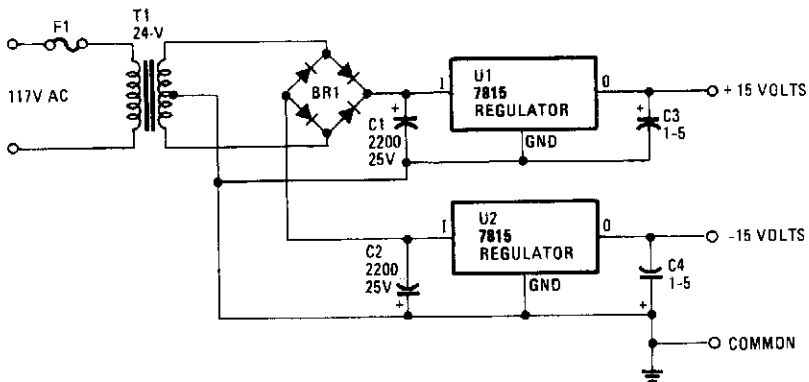

Fig. 70-9

RADIO-ELECTRONICS

A simple bridge rectifier feeds two IC regulators. This circuit should be useful for op-amp circuitry.

71

Power Supply Circuits (Variable Output)

The sources of the following circuits are contained in the Sources section, which begins on page 707. The figure number in the box of each circuit correlates to the entry in the Sources section.

Variable Voltage Regulator with Current Crowbar Limiting
Adjustable 0- to 5-V Supply
Transceiver Power Supply for Variable Lab Source
Adjustable Power Supply
Variable-Voltage Regulator with Wide-Range Current Limiting
General-Purpose 0- to 30-V Power Supply
Adjustable Positive Regulator
Adjustable Bias Regulator

VARIABLE VOLTAGE REGULATOR WITH CURRENT CROWBAR LIMITING

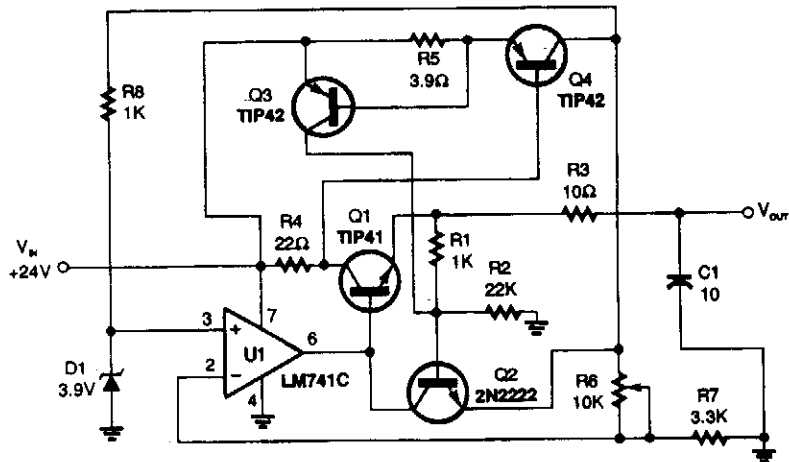

A

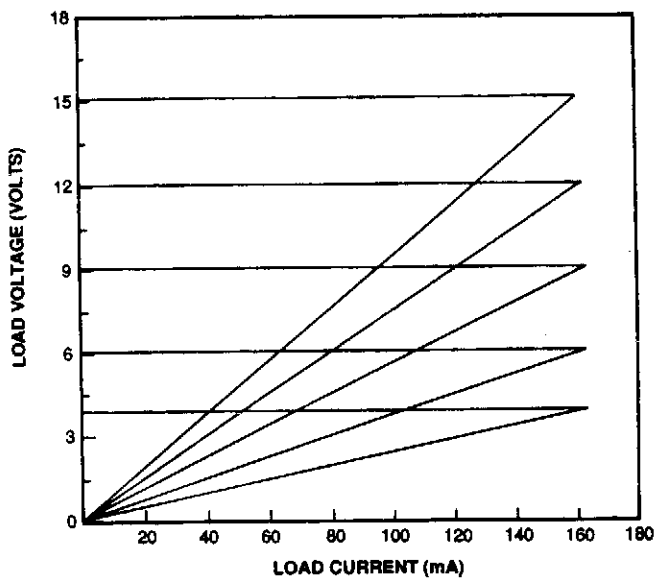

B

POPULAR ELECTRONICS

Fig. 71-1

The variable voltage regulator with current-crowbar limiting, shown in Fig. 71-1A, overcomes the disadvantages of constant and foldback limiting. As you can see in the graph (Fig. 71-1B), the current crowbar quickly shuts down the supplied power when a preset current is exceeded. It also has excellent load regulation over its operating range.

ADJUSTABLE 0- TO 5-V SUPPLY

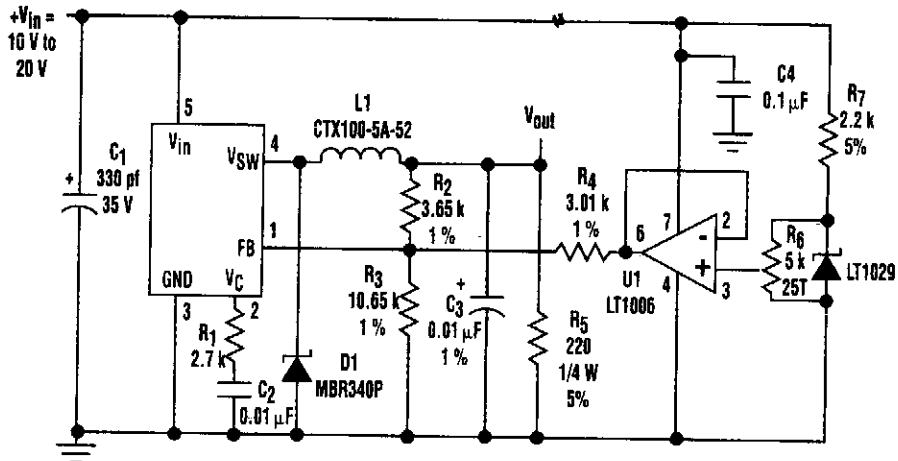

ELECTRONIC DESIGN

Fig. 71-2

Although linear-regulator ICs are frequently used in variable power-supply applications, they might not always be the best choice. At low output voltages, power losses in these regulators can cause headaches for designers. For example, if an output current of 1.25 A is required at 1.25 V from an input of 8 V, a regulator (such as the LT317) dissipates more than 10 W.

The figure depicts a dc-dc converter that functionally replaces a linear regulator in the just described application. The converter not only eliminates the problem of power loss, but it can be adjusted for output voltages (as low as 25 mV) while delivering an output current of 1.5 A.

The circuit uses a basic positive-buck topology with one exception. A control voltage is applied through R4 to the feedback summing node at pin 1 of the LT1076 regulator IC, making it possible to adjust the output from 0 V to approximately 6 V. This range encompasses the 3.3-V and 5-V logic supply voltages for portable and desktop equipment, as well as battery-pack combinations of one to four cells.

As R4 is driven from 0 to 5 V by the buffer (U1), more or less current is required from R2 to satisfy the loop's desire to hold the feedback summing point at 2.37 V. This forces the converter's output to swing over the range of 0 to 6 V.

The LT1076 is capable of 1.75-A guaranteed output current in this application, and 2 A is typical. If more current is required, the LT1074 can be substituted for the LT1076.

TRANSCEIVER POWER SUPPLY FOR VARIABLE LAB SOURCE

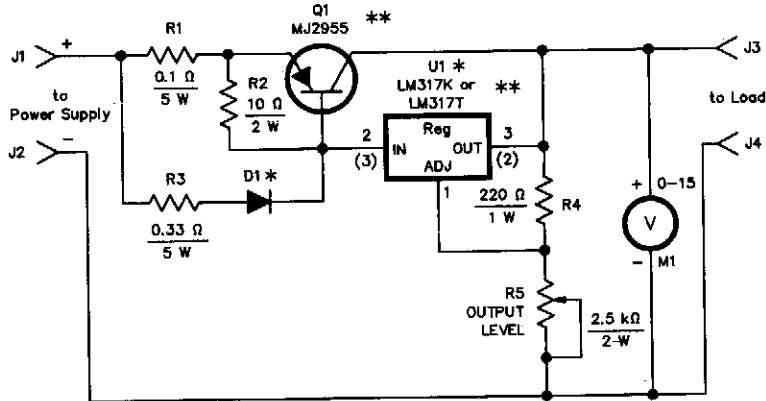

* See text and caption
 ** Heat Sink

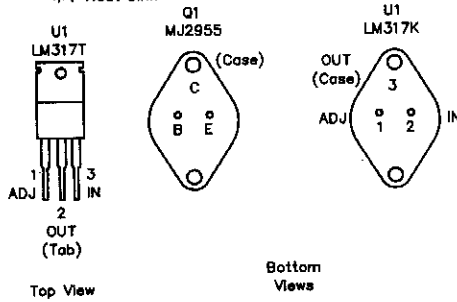

Fig. 71-3

QST

A variable voltage regulator provides 1 to 11 Vdc for lab bench work, using an existing 13.8-V transceiver supply.

ADJUSTABLE POWER SUPPLY

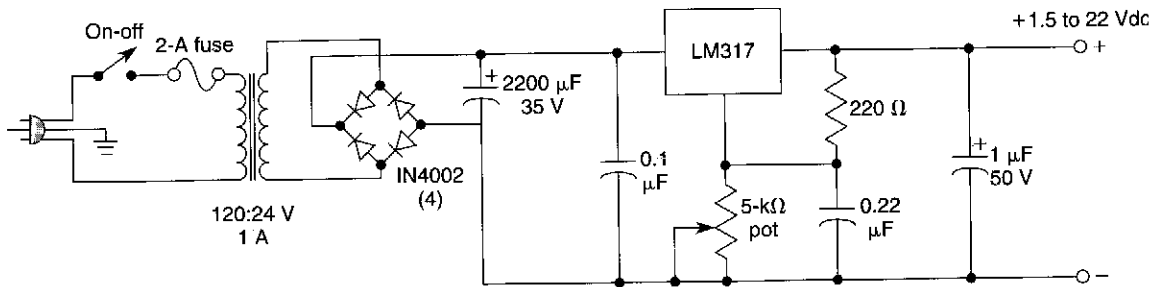
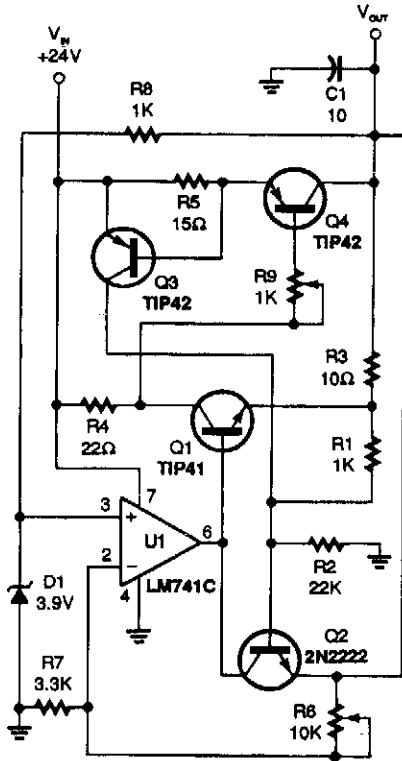

Fig. 71-4

WILLIAM SHEETS

Using an LM317, this supply delivers 1.25 to 22 Vdc for various purposes. The LM317 should be heatsinked. This supply will deliver 600-mA output current.

VARIABLE-VOLTAGE REGULATOR WITH WIDE-RANGE CURRENT LIMITING



In this circuit, R9 acts as a control to set current limiting. If $R_9 = 0$, limiting occurs at 47 mA. Input is 24 V, output is

$$\frac{(R_6 + R_7)}{R_7} \times \quad (3.9)$$

depending on the setting of R6.

POPULAR ELECTRONICS

Fig. 71-5

GENERAL-PURPOSE 0- TO 30-V POWER SUPPLY

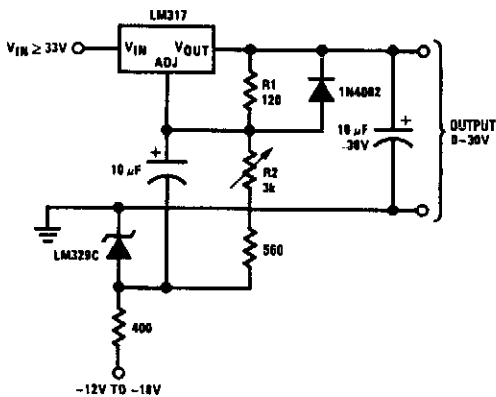

NATIONAL SEMICONDUCTOR

Fig. 71-6

ADJUSTABLE POSITIVE REGULATOR

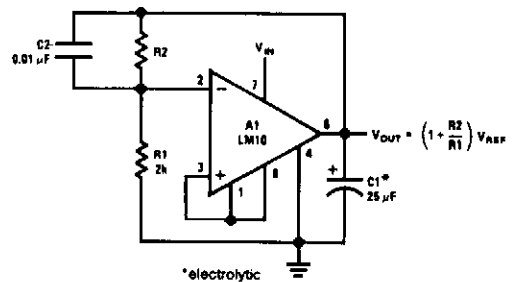

NATIONAL SEMICONDUCTOR

Fig. 71-7

ADJUSTABLE BIAS REGULATOR

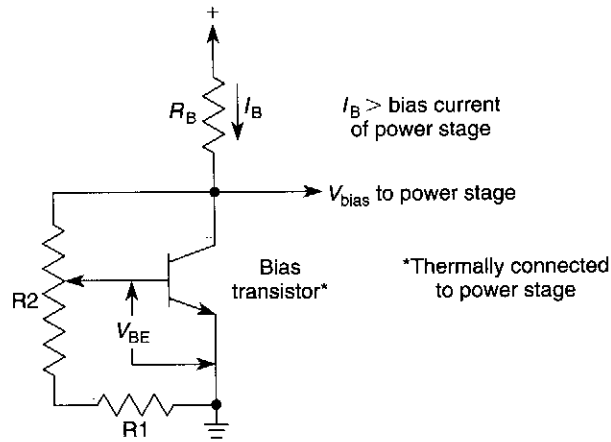

WILLIAM SHEETS

Fig. 71-8

If the wiper of R2 is set at $N\%$ rotation, the bias voltage will be:

$$V_{\text{BIAS}} = V_{\text{BE}} \left(\frac{R_1 + NR_2}{R_1 + R_2} \right)$$

$$V_{\text{BIAS MIN}} = V_{\text{BE}} \quad V_{\text{BIAS MAX}} = \left(\frac{R_1 + R_2}{R_1 + R_2} \right) V_{\text{BE}}$$

This method derives a bias voltage that tracks V_{BE} of this bias transistor. If the bias transistor is thermally linked to the power stage, tracking over a wide temperature range will result.

72

Probe Circuits

The sources of the following circuits are contained in the Sources section, which begins on page 707. The figure number in the box of each circuit correlates to the entry in the Sources section.

Current Probe Amplifier
Simple Logic Probe with Alphanumeric Display
Simple RF Probe
125-MHz Logic Probe
pH Probe Amplifier
8-Digit 100-MHz Frequency Probe

CURRENT PROBE AMPLIFIER

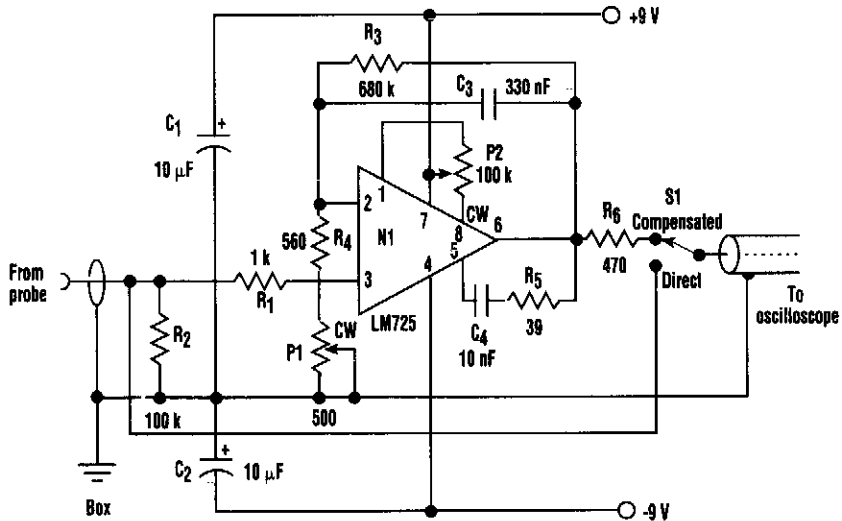

ELECTRONIC DESIGN

Fig. 72-1

A clamp-on current probe, such as the Tektronix P6021, is a useful means of displaying current waveforms on an oscilloscope. A less-expensive and simple alternative is shown in the figure.

The more sensitive range on the P6021 is 2 mA/mV, but it has a roll-off of 6-dB per octave below 450 Hz. The purpose of the compensator is to counteract the low-frequency attenuation, which is achieved by means of C_3 and $R_4 + P_1$ in the feedback around op amp N1. It's important that the latter is a low-noise type, such as the LM725 shown in the figure. On top of that, it's necessary at some point to limit the increasing gain with decreasing frequency; otherwise, amplifier noise and drive will overcome the signal. The values shown for C_3 and R_3 give a lower limit of less than 1 Hz.

A test square wave of ± 1 mA is fed to the current probe so that P_1 can be adjusted for minimum droop or overshoot in the output waveform. It's vital that the sliding core on the probe is fully closed. At high frequencies, the response begins to fall off at 100 kHz. Therefore, for most waveforms, switch S1 is moved to "direct," above a fundamental frequency of, for example, 10 kHz.

This circuit's current consumption is quite low, and it can be battery powered. If a mains power supply is built-in, it must be well screened to prevent hum problems.

SIMPLE LOGIC PROBE WITH ALPHANUMERIC DISPLAY

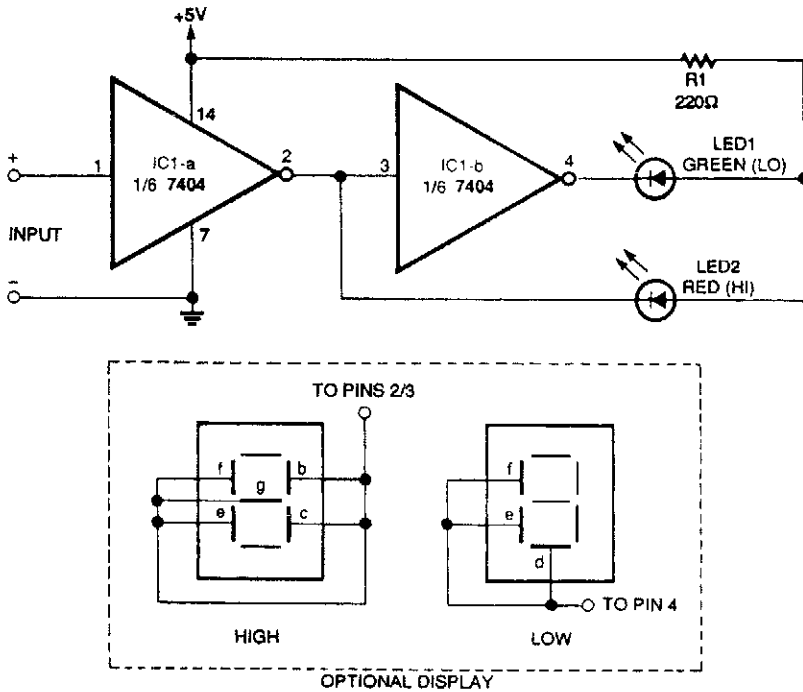
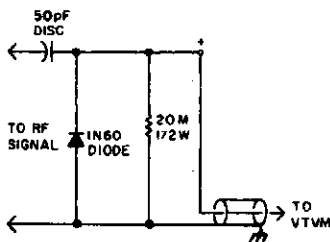

Fig. 72-2

ELECTRONICS NOW

A logic probe also includes BCD decoder module. The red LED lights to indicate a logic high, and the green LED lights to indicate a logic low. This probe circuit will light a green (low) or red (high), and if desired, an alphanumeric display can be obtained with two 7-segment LED displays.

SIMPLE RF PROBE



Your VTVM can measure peak voltage up to 200 MHz by using this probe. The maximum RF that can be measured is determined by the diode; with a 1N60, the probe is limited to 30 V. To increase the capacity, substitute a higher-voltage small-signal detector diode. House the circuit in a metal enclosure and use shielded wire.

73 AMATEUR RADIO TODAY

Fig. 72-3

125-MHz LOGIC PROBE

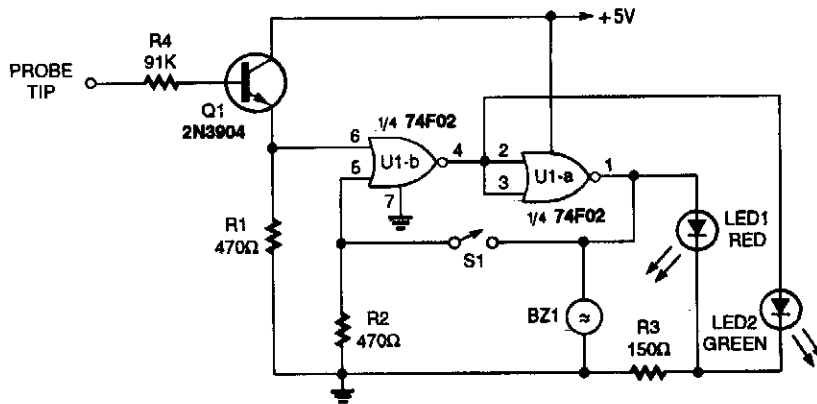

POPULAR ELECTRONICS

Fig. 72-4

This logic probe features either high-low (LED) indication or latching operation. When S1 is closed, the indication of a pulse is latched and the red LED1 stays on. Piezoelectric buzzer BZ1 is used as a beeper to sound that a logic high is preset.

pH PROBE AMPLIFIER

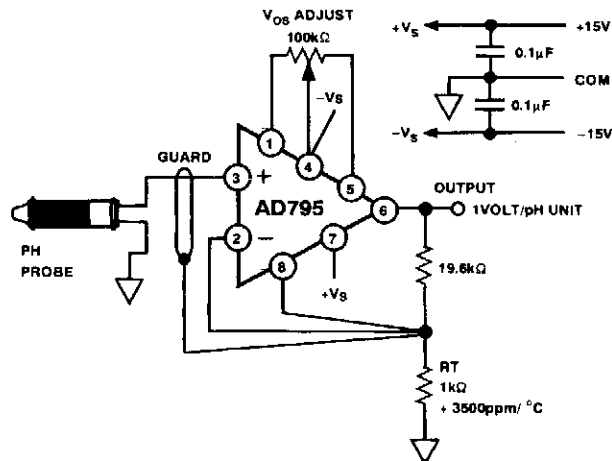

ANALOG DEVICES

Fig. 72-5

The low-noise precision FET op-amp AD795 has around 1014-Ω common-mode impedance, low-offset voltage ($250 \mu\text{V}_{\text{max}}$) and $13 \mu\text{V}_C$ drift make this device ideal for low-voltage measurements from high-impedance sources.

8-DIGIT 100-MHz FREQUENCY PROBE

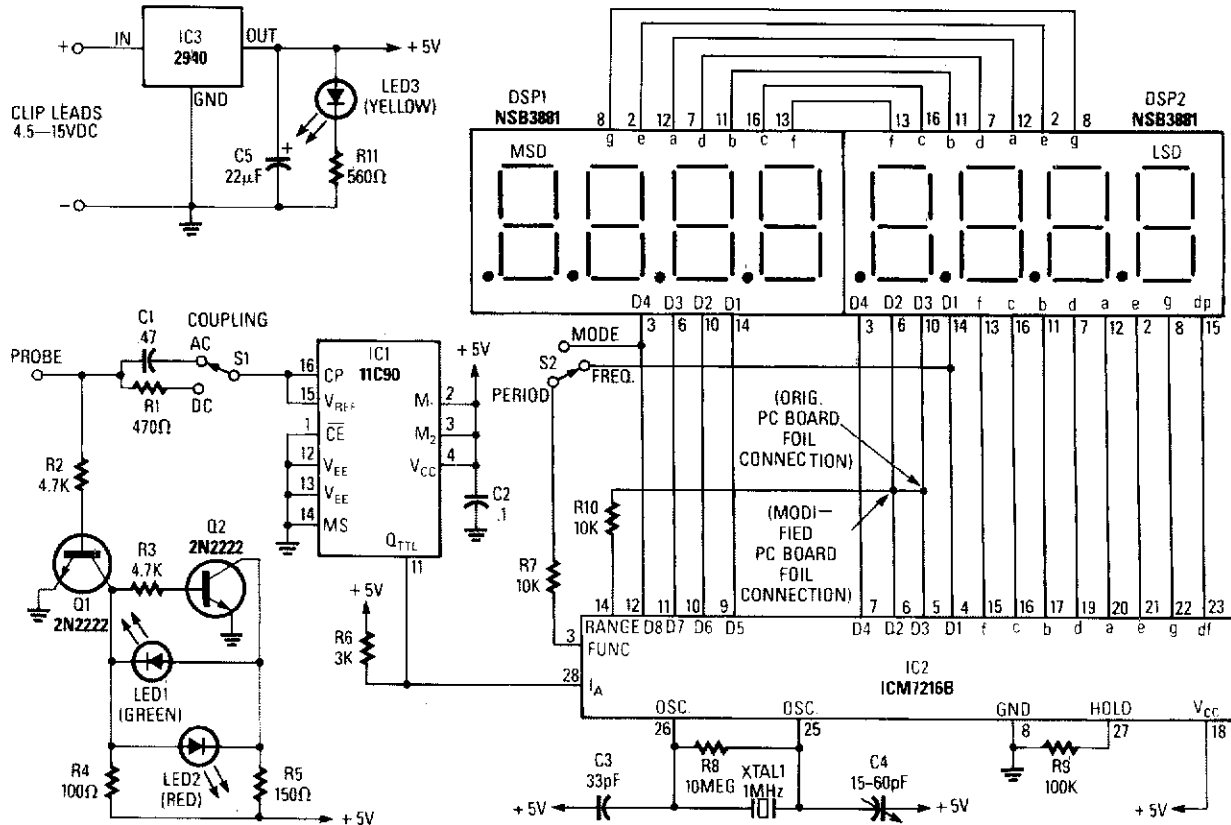

RADIO-ELECTRONICS

Fig. 72-6

Small enough to mount in a probe, this frequency counter circuit is good to 100 MHz. It operates from +5 to +15 Vdc. An 11C90 prescaler drives a 10-MHz counter chip (ICM7216B). Note the dotted line connecting R10 with pins 5 and 6 of IC2; that variable connection controls the decimal point and total count appearing on DSP1 and DSP2. The relative intensities and durations of ON/OFF time for LED1 (green) and LED2 (red) give a rough indication of logic level and duty cycle.

73

Protection Circuits

The sources of the following circuits are contained in the Sources section, which begins on page 707. The figure number in the box of each circuit correlates to the entry in the Sources section.

Short-Circuit Protection Circuit
Polarity Protector

SHORT-CIRCUIT PROTECTION CIRCUIT

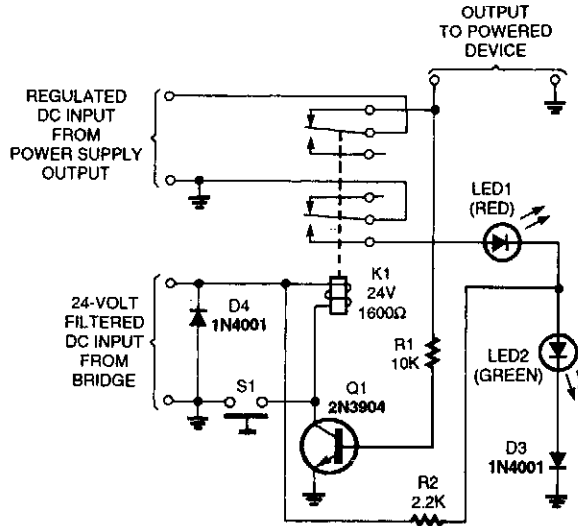

POPULAR ELECTRONICS

Fig. 73-1

When S1 is pressed, the coil of K1 is energized, closing its normally open contacts. If the regulated dc input is between 1 and 24 V, that voltage feeds the base of Q1 through R1, turning on the transistor, and latching the relay. When that occurs, LED2 glows indicating that all is okay.

If there is a short to ground at the circuit's output (i.e., in the device being powered), the voltage that feeds the base of Q1 goes to zero, turning off the transistor. Then, LED1 glows because K1 is de-energized to indicate the short circuit.

POLARITY PROTECTOR

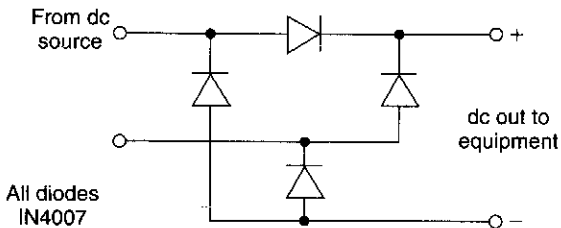

The use of a four-diode bridge guarantees correct polarity irrespective of input dc polarity. Remember that two diode drops (about 1.2 to 1.5 V) are lost from the input voltage using this circuit.

WILLIAM SHEETS

Fig. 73-2

74

Radar Detector Circuits

The sources of the following circuits are contained in the Sources section, which begins on page 707. The figure number in the box of each circuit correlates to the entry in the Sources section.

Display Board for Radar Gun
2.6-GHz Oscillator for Radar Speed Gun

DISPLAY BOARD FOR RADAR GUN

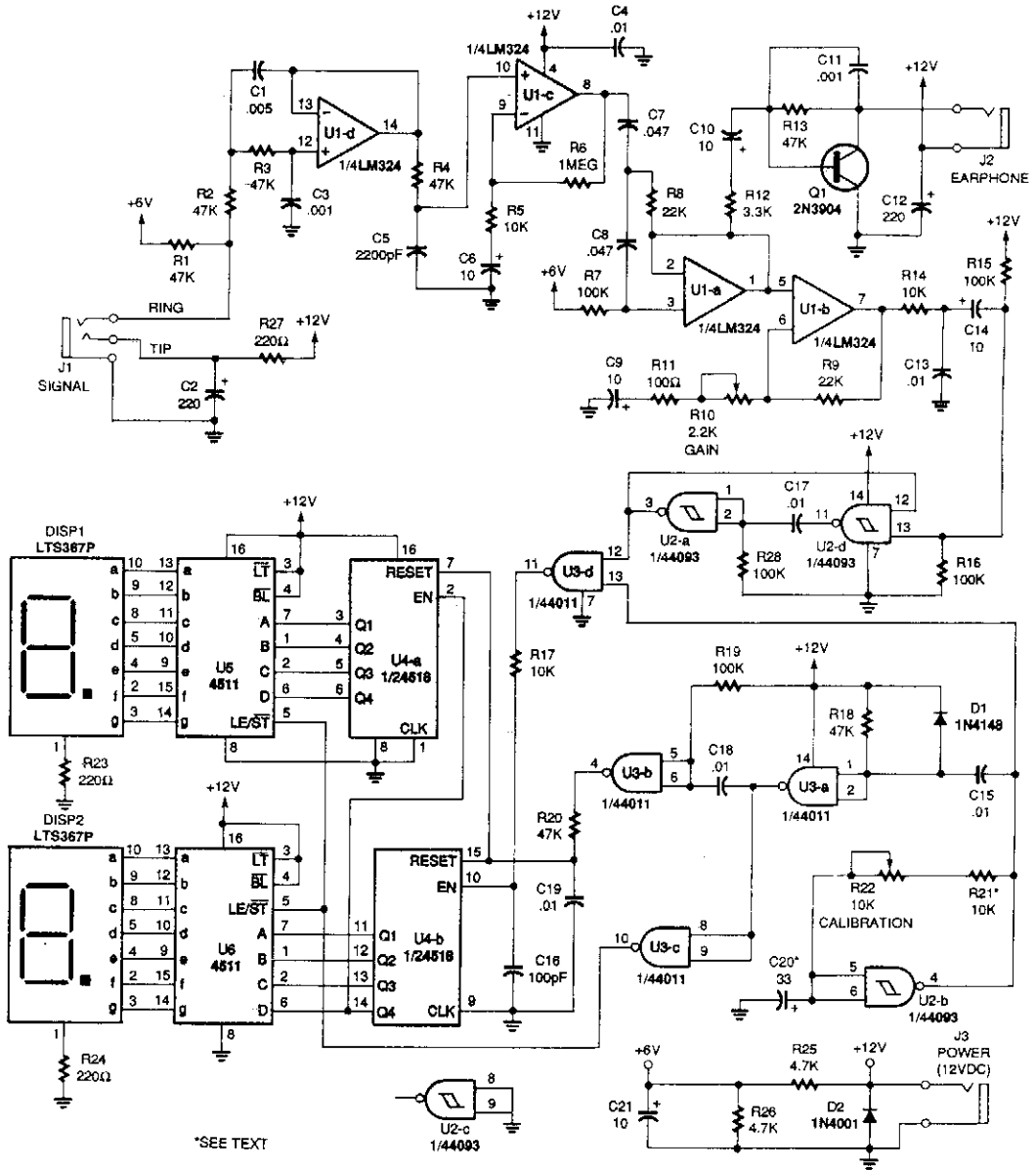

POPULAR ELECTRONICS

Fig. 74-1

This circuit takes signal (doppler) from a radar gun, amplifies and limits it, and feeds the frequency into a counter (U4) and display circuit (DISP1, DISP2, U5, U6). Counter calibration is set by clock circuit U2B. Calibration is obtained via R21 and R22. R21 can be changed if kilometers/hour readout is desired.

2.6-GHz OSCILLATOR FOR RADAR SPEED GUN

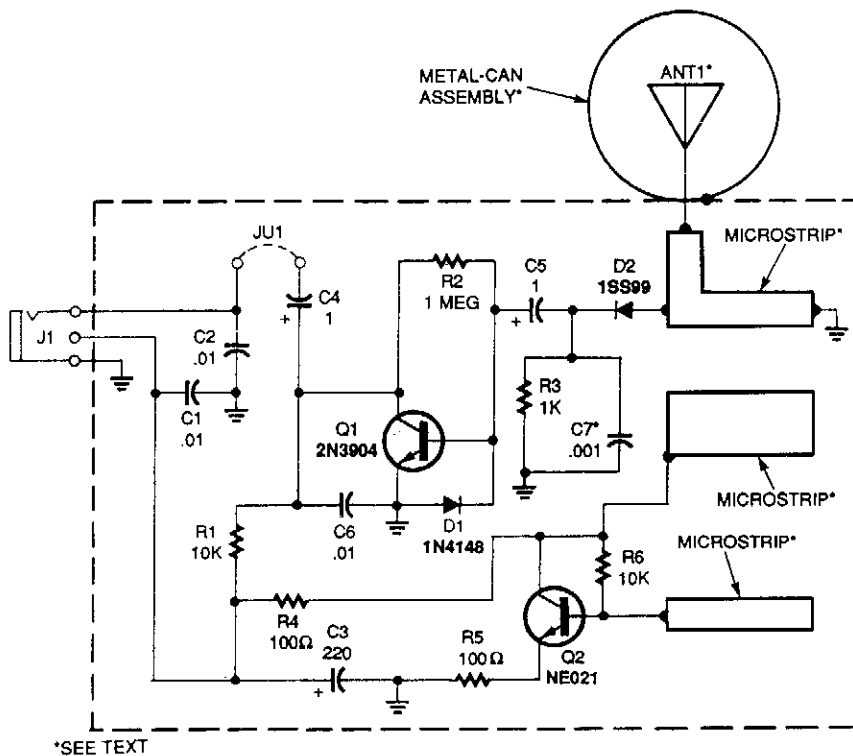

POPULAR ELECTRONICS

Fig. 74-2

This circuit consists of 2.6-GHz oscillator Q2, a coupling microstripline to ANT1, a 1.1" $\frac{1}{4}$ -wave probe, detector D2, and audio amp Q1. The oscillator feeds power to the antenna, which radiates the signal. The reflected signal from a moving target mixes with the oscillator signal in D2. The resultant beat note (doppler shift) is amplified by Q1 and fed to jack J1, which is used to feed the circuit 12 Vdc.

75

Radiation Detector Circuits

The sources of the following circuits are contained in the Sources section, which begins on page 707. The figure number in the box of each circuit correlates to the entry in the Sources section.

- Geiger Counter
- Voltage Tripler for Radon Detector Ionization Chamber
- Flyback Power Supply for Radon Monitor
- Radon Monitor Amplifier and Head
- Ion Detector

GEIGER COUNTER

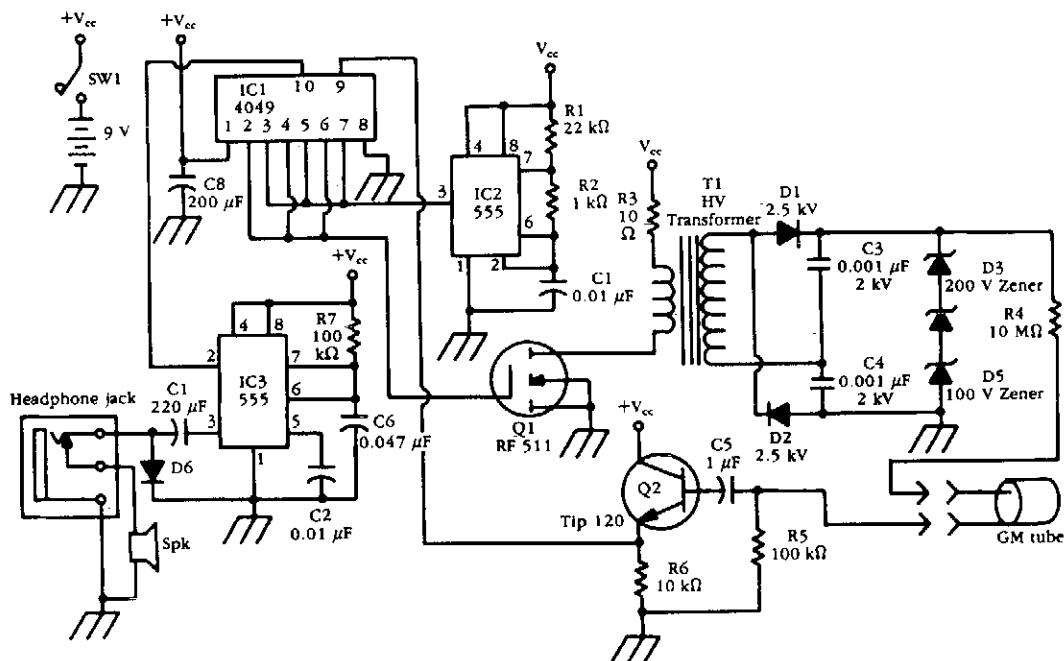

McGRAW-HILL

Fig. 75-1

An HV generator (IC1, IC2, Q1, T1, and associated components) power a G-M tube. A pulse from the GM tube is interfaced through Q2 and IC1 to pulse generator IC3, which drives a speaker.

VOLTAGE TRIPLER FOR RADON DETECTOR IONIZATION CHAMBER

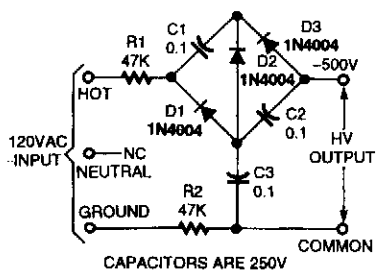

ELECTRONICS NOW

Fig. 75-2

The voltage tripler charges the ionization chamber capacitor. It is powered from the 120-Vac line. Warning: Shock hazard exists.

FLYBACK POWER SUPPLY FOR RADON MONITOR

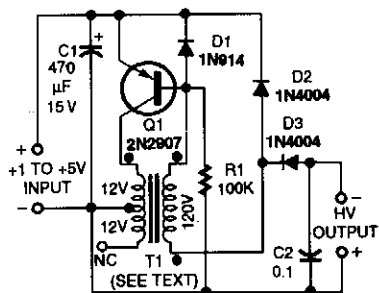

ELECTRONICS NOW

Fig. 75-3

This blocking-oscillator flyback circuit is an alternative for charging the ionization chamber capacitor.

RADON MONITOR AMPLIFIER AND HEAD

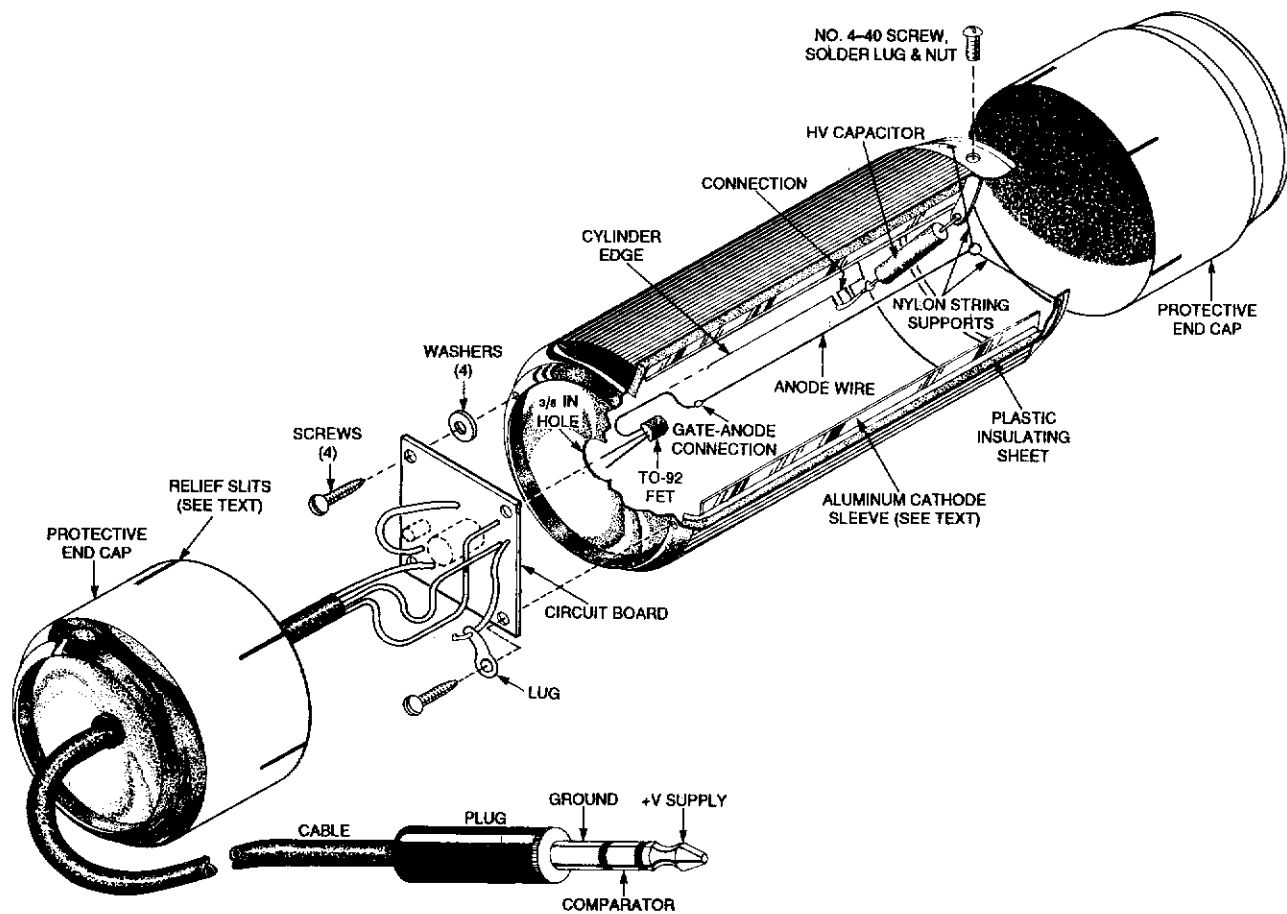

RADON MONITOR AMPLIFIER AND HEAD (Cont.)

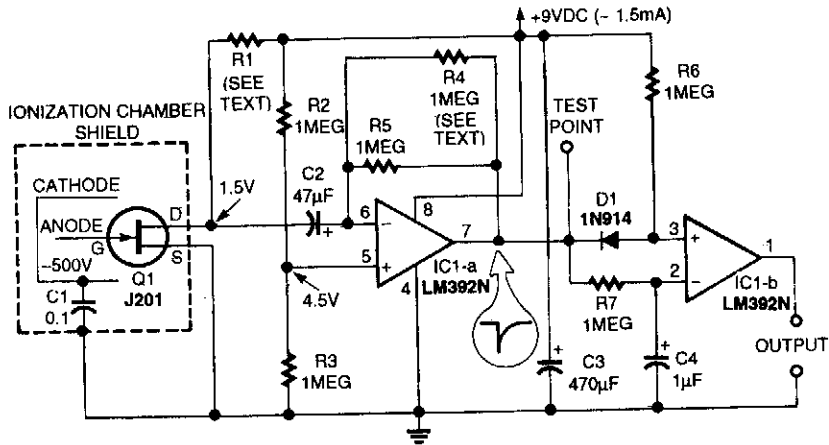

Fig. 75-4

ELECTRONICS NOW

A positively charged anode wire attracts electrons and a negatively charged cathode attracts positively charged ions. The recombination of electrons and ions causes a current that produces a voltage pulse. The cathode is maintained at -500 V by a charge on the $0.1\text{-}\mu\text{F}$ capacitor.

A beverage can forms the chamber, an aluminum can forms the cathode, and half cans form protective end covers. The amplifier circuit board is shown to the left of center.

ION DETECTOR

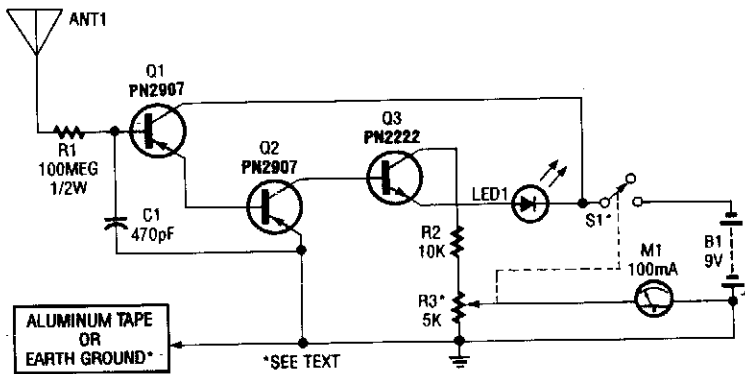

Fig. 75-5

POPULAR ELECTRONICS

ANT1 is a short whip antenna from a junked radio or other device. R_3 is adjusted to bring the meter on scale. This device should be grounded to operate properly. A length of aluminum or copper foil tape attached to the instrument case makes contact with the hand, and the body serves as a ground via hand contact with this tape.

76

Receiving Circuits

The sources of the following circuits are contained in the Sources section, which begins on page 707. The figure number in the box of each circuit correlates to the entry in the Sources section.

AM Radio	Two-Chip AM Receiver
ac/dc Vacuum-Tube AM and Shortwave Receiver	Relay Interface to RC Receivers
WWV Receiver	Basic Regenerative Receiver
Shortwave Receiver	Simple Radio Receiver
AM/FM Receiver Circuit	One-Tube AM Receiver
118- to 136-MHz Aircraft Receiver	Balanced Line Receiver
Dual-Inverter Line Receiver	Superhet Front End
Toroidal-Core TRF Shortwave Receiver	Receiver Preamp
Nine-Band Shortwave Receiver	Regenerative Receiver for 6 to 17 MHz
One-Tube Regenerative SW Receiver	Two-Stage TRF Regenerative Receiver
One-Tube Regenerative AM Receiver	Economy Shortwave Receiver
Two-Band Radio	Variometer-Tuned Radio
Simple Crystal Radio	Old-Fashioned Crystal Radio
Video Line Receiver	WWV Receiver

AM RADIO

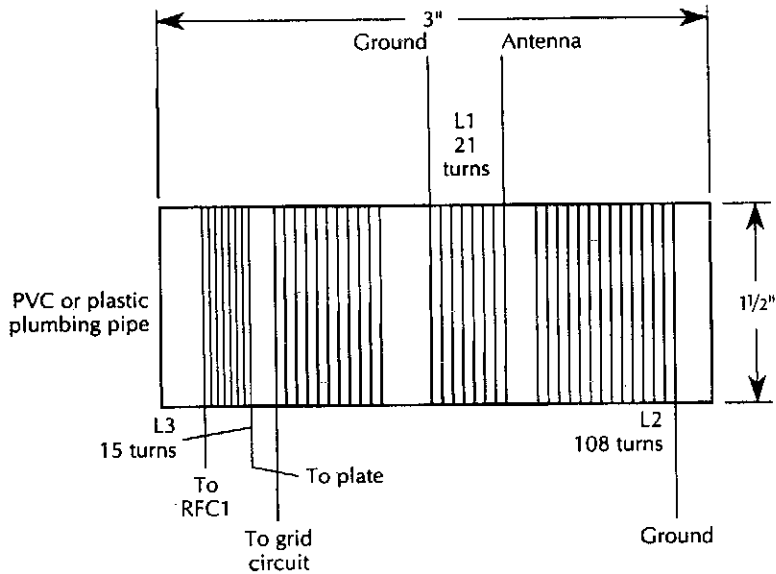
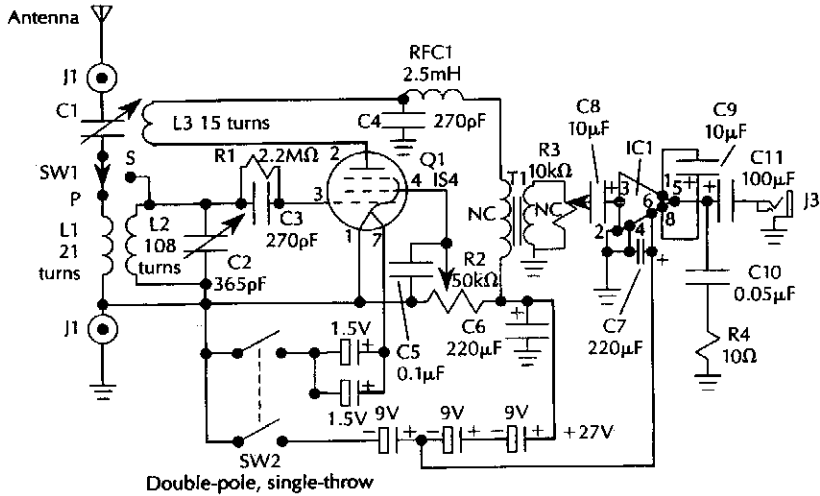

The primary winding of L1 has 21 turns of #24 or #26 enameled wire; L2 has 108 turns; and L3 has 15 turns of wire. All are wound on 1½-inch PVC pipe form.

McGRAW-HILL

Fig. 76-1

A 1S4 regenerative detector feeds an LM386 audio IC (IC1). 1.5-V D cells and three 9-V batteries are used for a power supply.

ac/dc VACUUM-TUBE AM AND SHORTWAVE RECEIVER

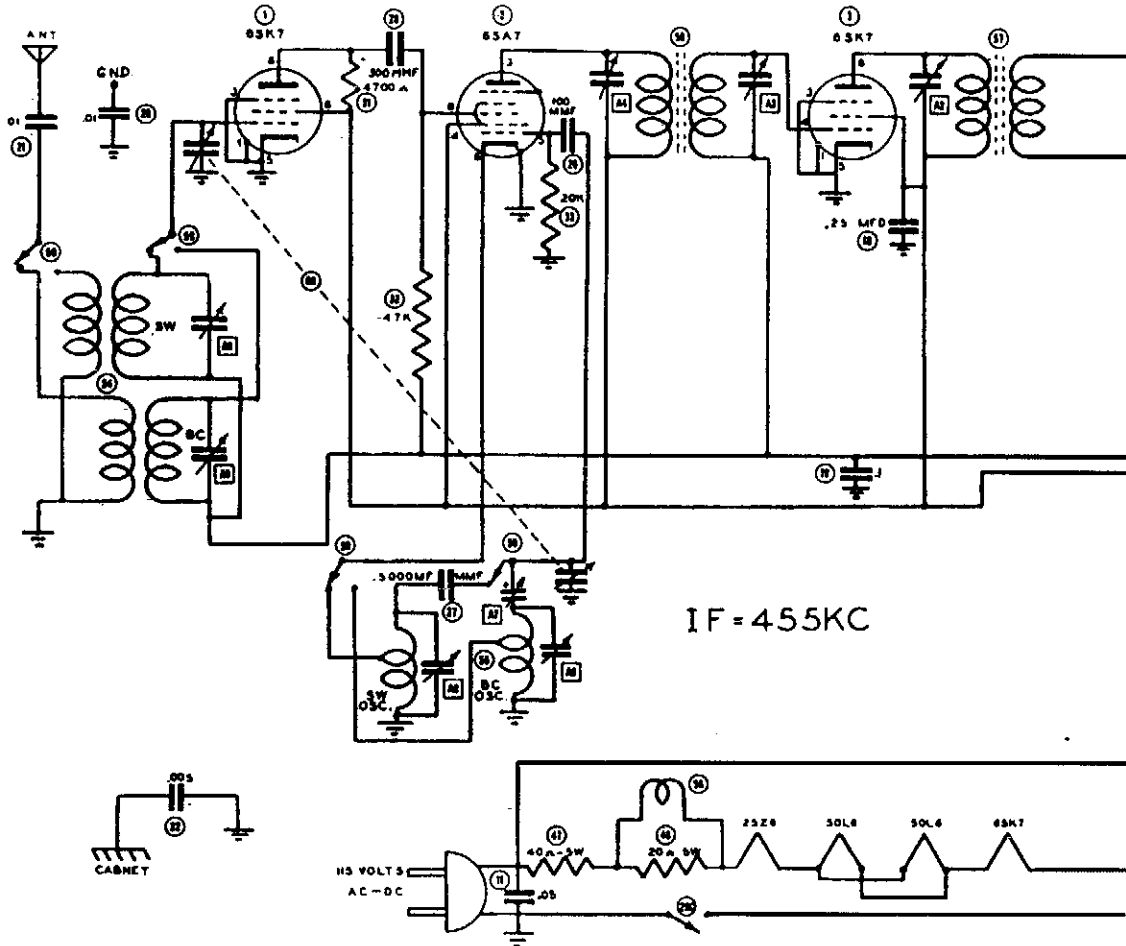

POPULAR ELECTRONICS

This circuit was used in a World War II vintage AM/SW (6 to 18 MHz) receiver and shows typical circuits used in receivers at that time.

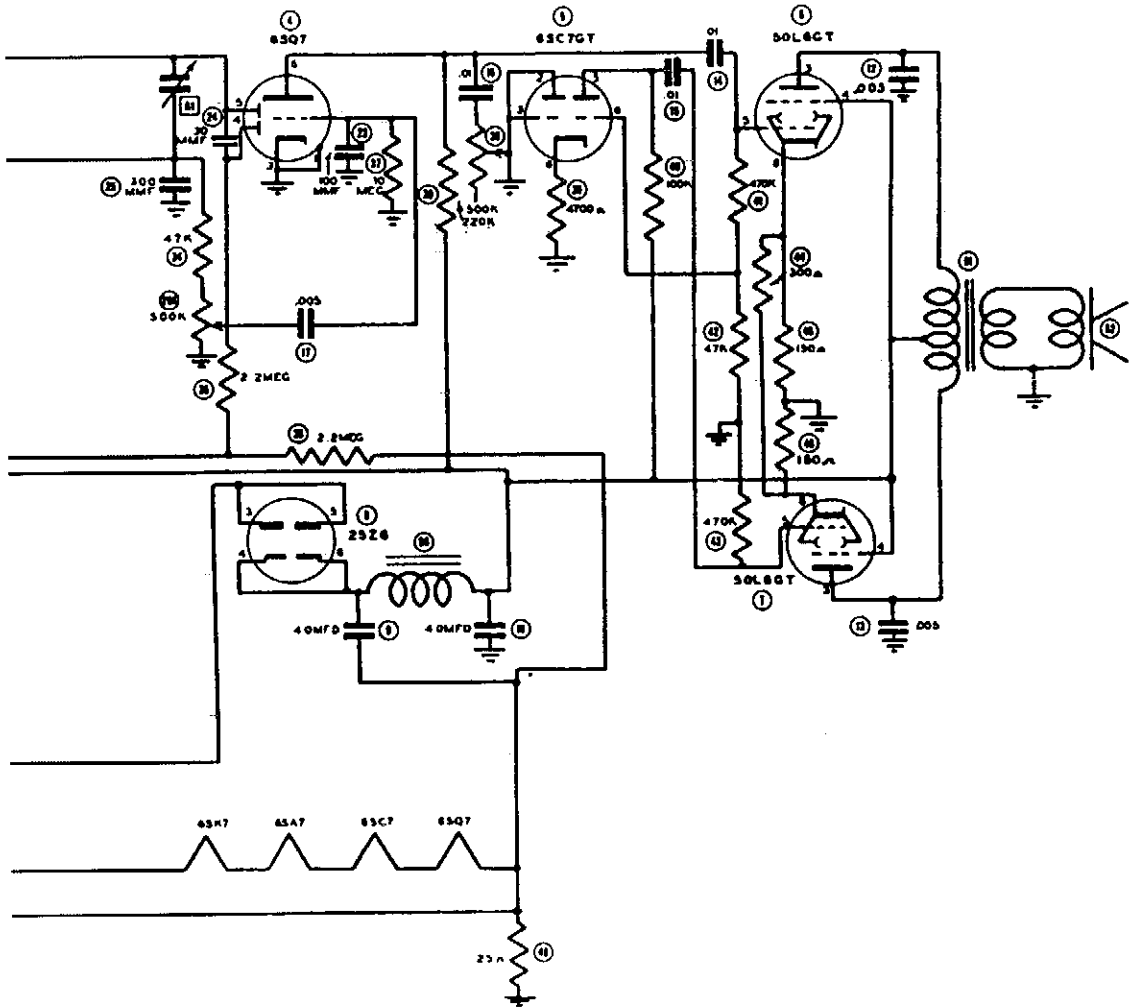
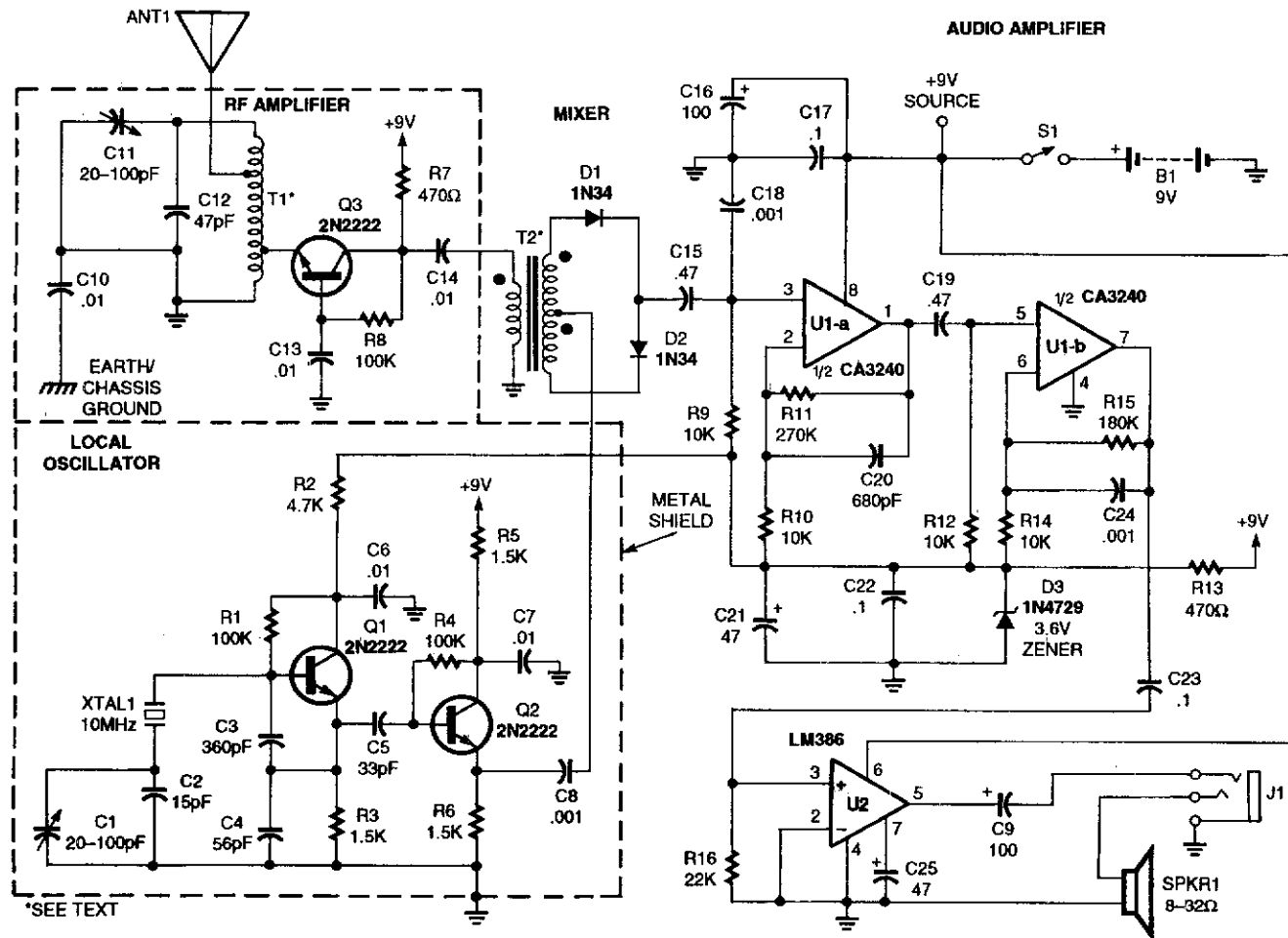
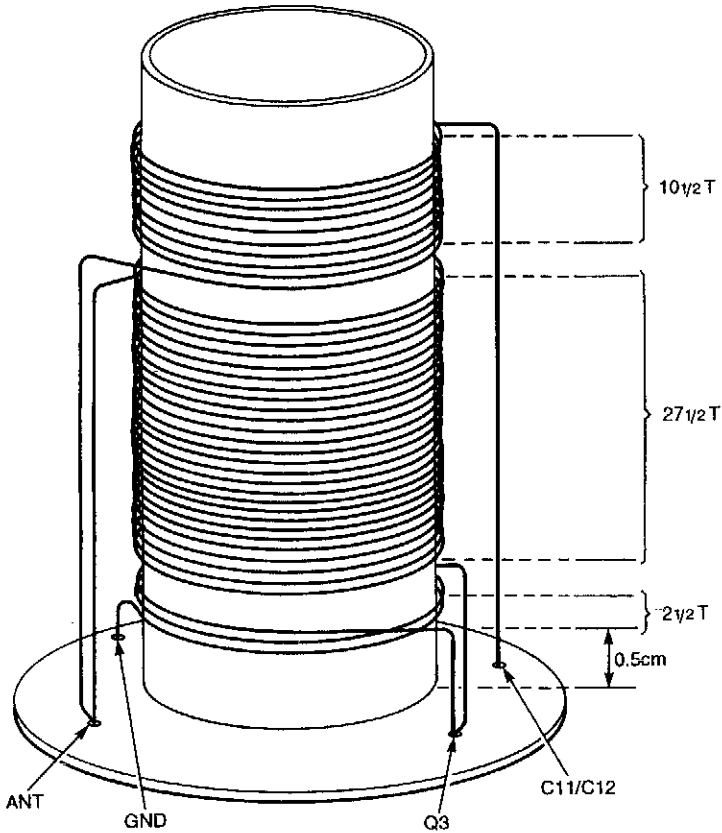

Fig. 76-2

WWV RECEIVER



WWV RECEIVER (Cont.)



Transformer T1 is a home-made unit comprised of 40 closely wound turns of #26 AWG enameled wire on a 1/4-inch diameter air-core form, with taps at 2½ and 10½ turns from each end; after each tap, the winding continues in the same direction.

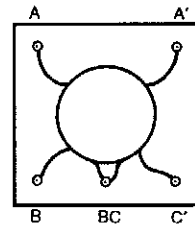
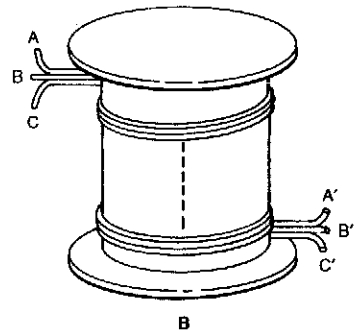
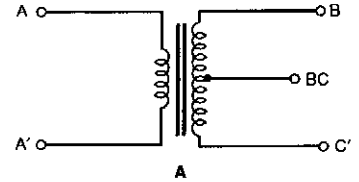

C

Construction details for T2 (the mixer transformer) are shown here. The diagram in A is a schematic representation of the unit once completed; B illustrates how the three lengths of wire are wound as a set on the bobbin; and C shows how the bobbin is connected to the pinned base.

RF amplifier Q3 feeds diode mixer D1–D2 and Q1–Q2 provide 10-MHz L.O. injection to D1 through T1 and T2. U1A, U1B and U2 are audio amplifiers. Details of T1 and T2 are shown.

SHORTWAVE RECEIVER

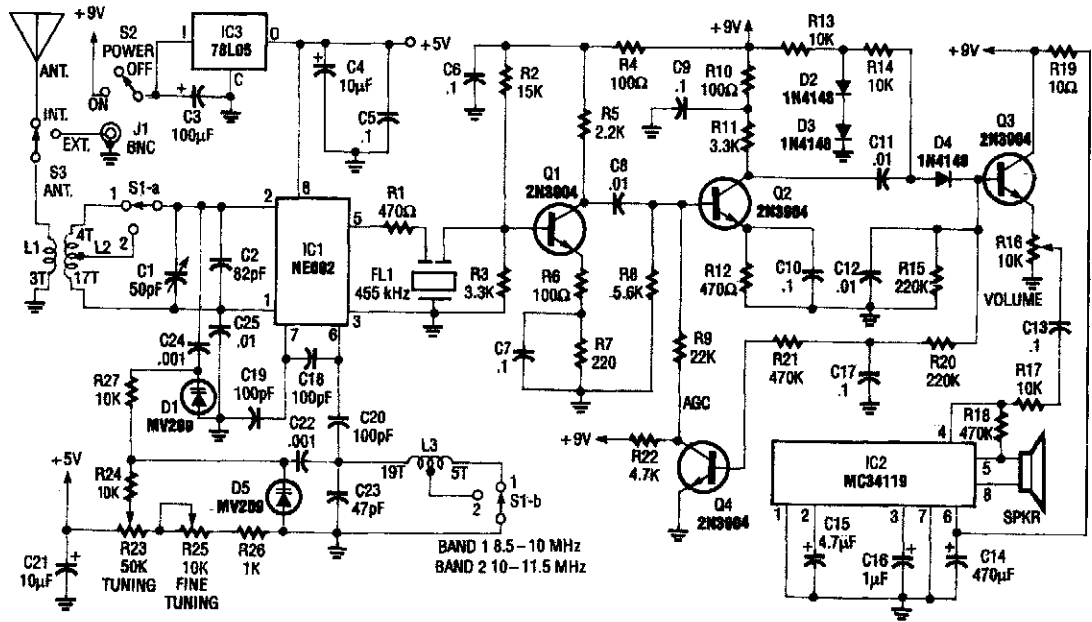

TABLE 2

Frequency (MHz)	C2 (pF)	C18, C19 (pF)	C23 (pF)	L1, L2 (Ant) (# of turns on T-37-2 core)	L3 (Osc)
5	100	120	68	5, 41	45
6	100	120	68	4, 30	34
7	82	100	47	4, 26	29
8	82	100	47	3, 22	24
10	82	100	47	3, 17	19
12	82	100	47	2, 15	17
14	68	82	33	2, 14	15
15	68	82	33	2, 13	14

TABLE 3

	NE602	MC34119		
Pin 1	1.27 V	0V		
Pin 2	1.27 V	4.15 V		
Pin 3	0V	4.11 V		
Pin 4	3.64 V	3.97 V		
Pin 5	3.59 V	4.14 V		
Pin 6	4.99 V	-9.09 V		
Pin 7	4.33 V	0V		
Pin 8	5.05 V	4.20 V		
	Q1	Q2	Q3	Q4
Emitter	0.95 V	0.80 V	0.27 V	0V
Base	1.61 V	1.45 V	0.82 V	0.58 V
Collector	2.56 V	3.30 V	9.17 V	7.41 V

This receiver covers 8.5 to 11.5 MHz in two bands and has a sensitivity of under 1 μV . An NE602 mixer feeds a 455-kHz IF amplifier (Q1 and Q2), detector D4, and audio amplifier IC2. Q4 serves as an AGC amplifier coil data is given in the table. The LO is varactor tuned.

AM/FM RECEIVER CIRCUIT

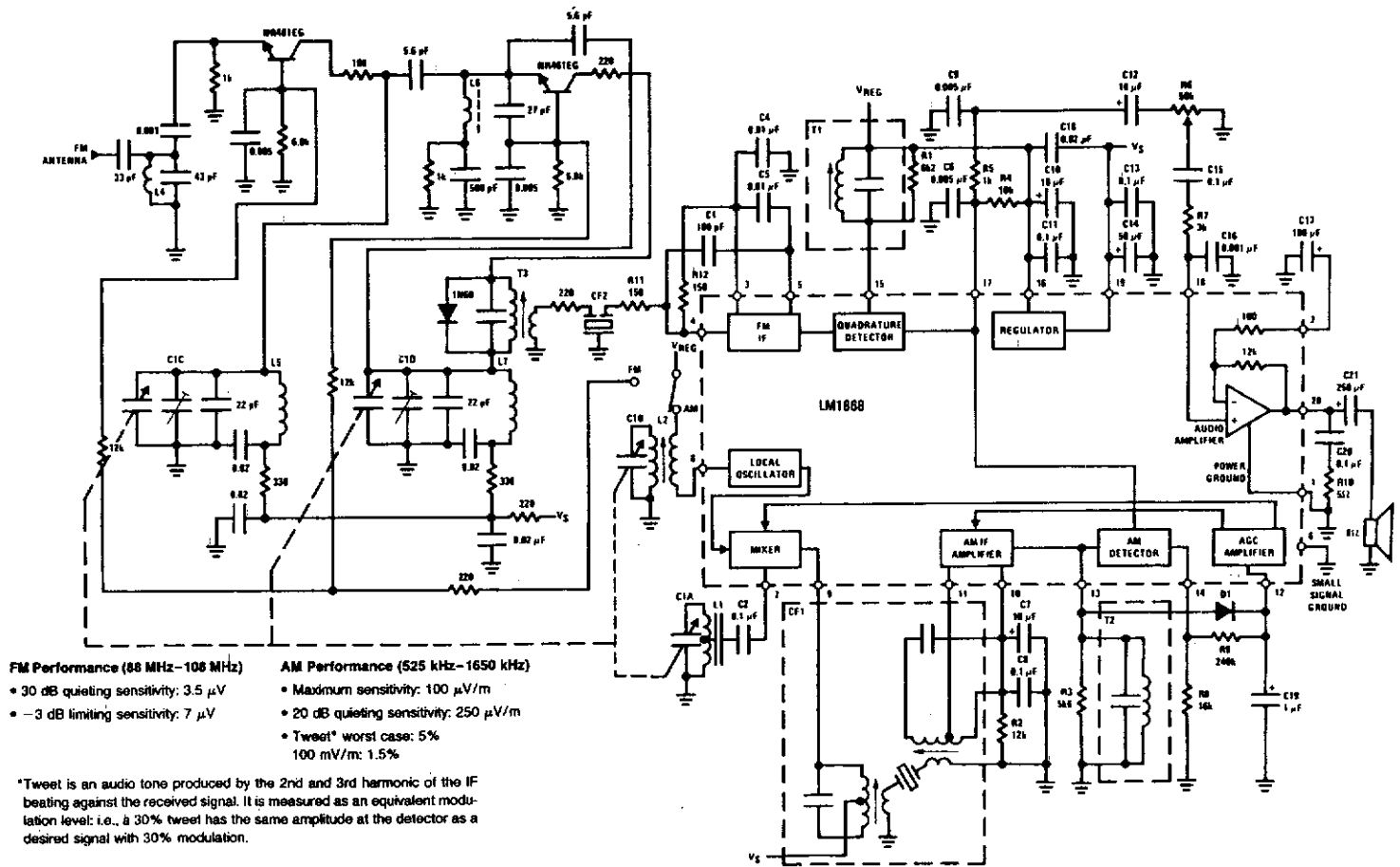

NATIONAL SEMICONDUCTOR

Fig. 76-5

This circuit shows the LM1868 as a complete AM radio and FM IF section. An external FM front end is used for the 88- to 108-MHz band. Audio output is 0.5 W and either 9-V battery or line operated supply can be used.

118- TO 136-MHz AIRCRAFT RECEIVER

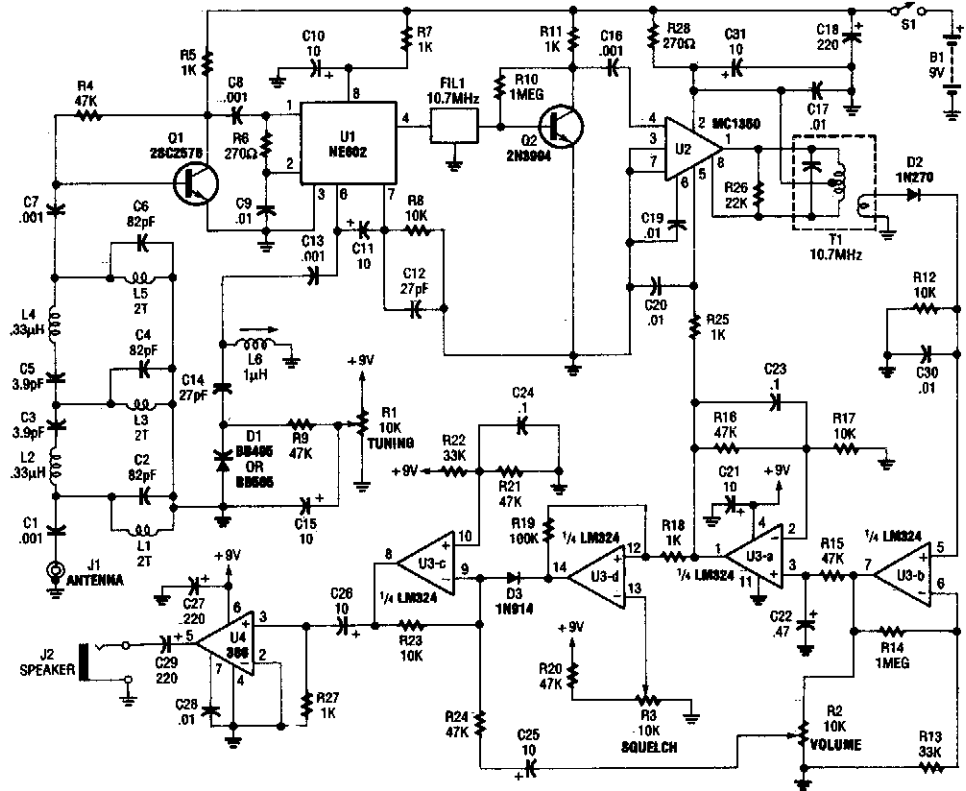

RADIO CRAFT

Fig. 76-6

This receiver covers the 118- to 136-MHz AM aviation band. It has a 10.7-MHz IF amplifier. L1, L3, and L5 are 1½ turns of #24 wire. F1L1 is a 10.7-MHz ceramic filter. IF bandwidth will be about 250 kHz.

DUAL-INVERTER LINE RECEIVER

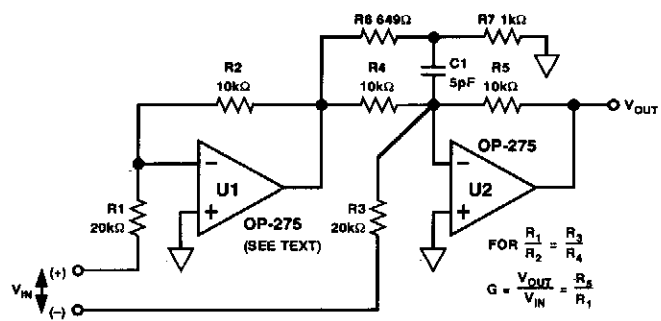

ANALOG DEVICES

Fig. 76-7

This circuit is for audio applications.

TOROIDAL CORE TRF SHORTWAVE RECEIVER

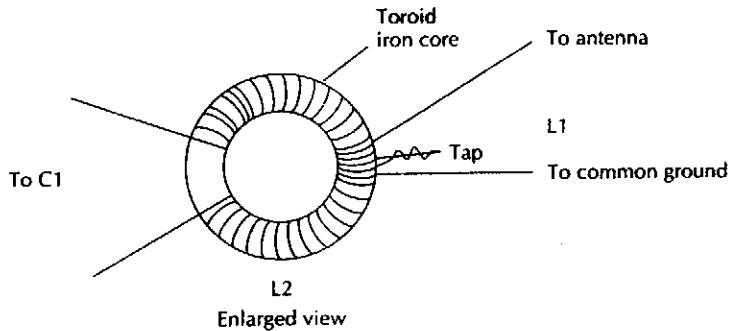
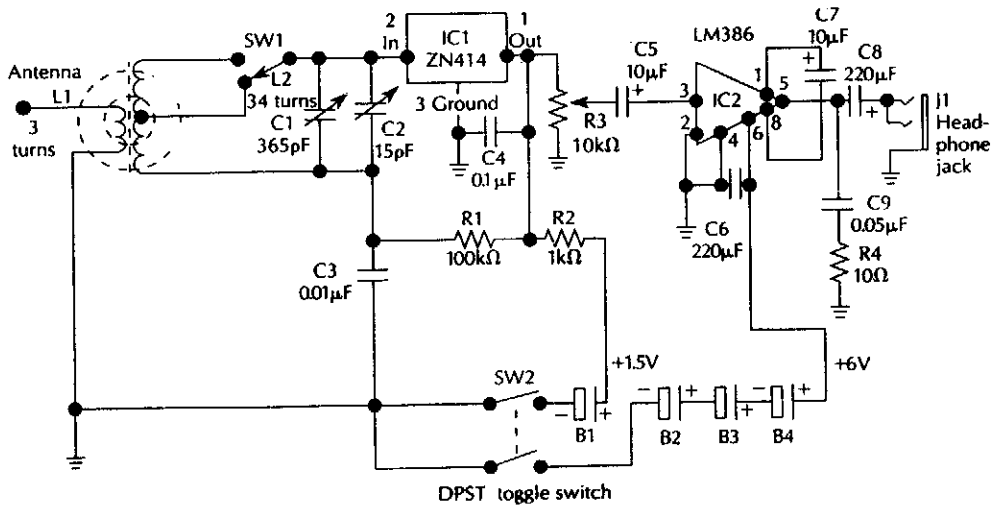

L1—3 turns of #24 enameled magnet wire wound over center of L2.
 L2—34 turns of #24 enameled wire—coils wound on toroid iron core form T-50-2—tapped at the 17th turn. Form has only 1/2-inch diameter.

Wind 34 turns, with a tap at the 17th turn, for L2 on the small 1/2-inch diameter iron core form.

McGRAW-HILL

Fig. 76-8

A ZN414 IC feeds an LM386 audio amplifier in this TRF circuit. SW1 is a band-switch. Coverage is up to 18 MHz.

NINE-BAND SHORTWAVE RECEIVER

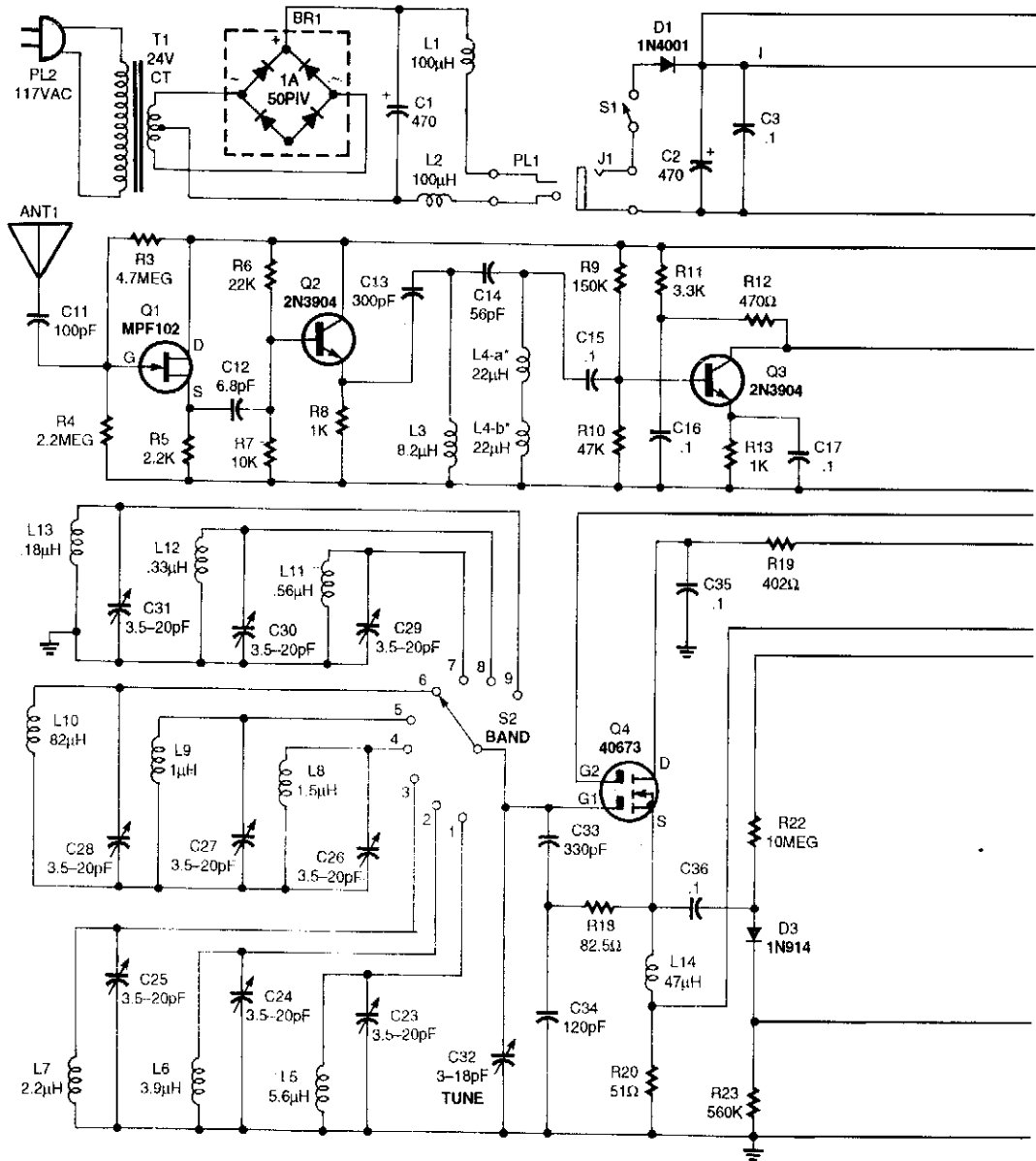

POPULAR ELECTRONICS

Dual-gate MOSFET Q4 is used as a regenerative amplifier in this circuit. An active antenna feeds the signal to Q4, and a short whip antenna is adequate. Detector Q5 feeds volume control R24, and audio amplifier U5, an LM386. The frequency range is 49 to 11 meters in nine bands (6 to 27 MHz).

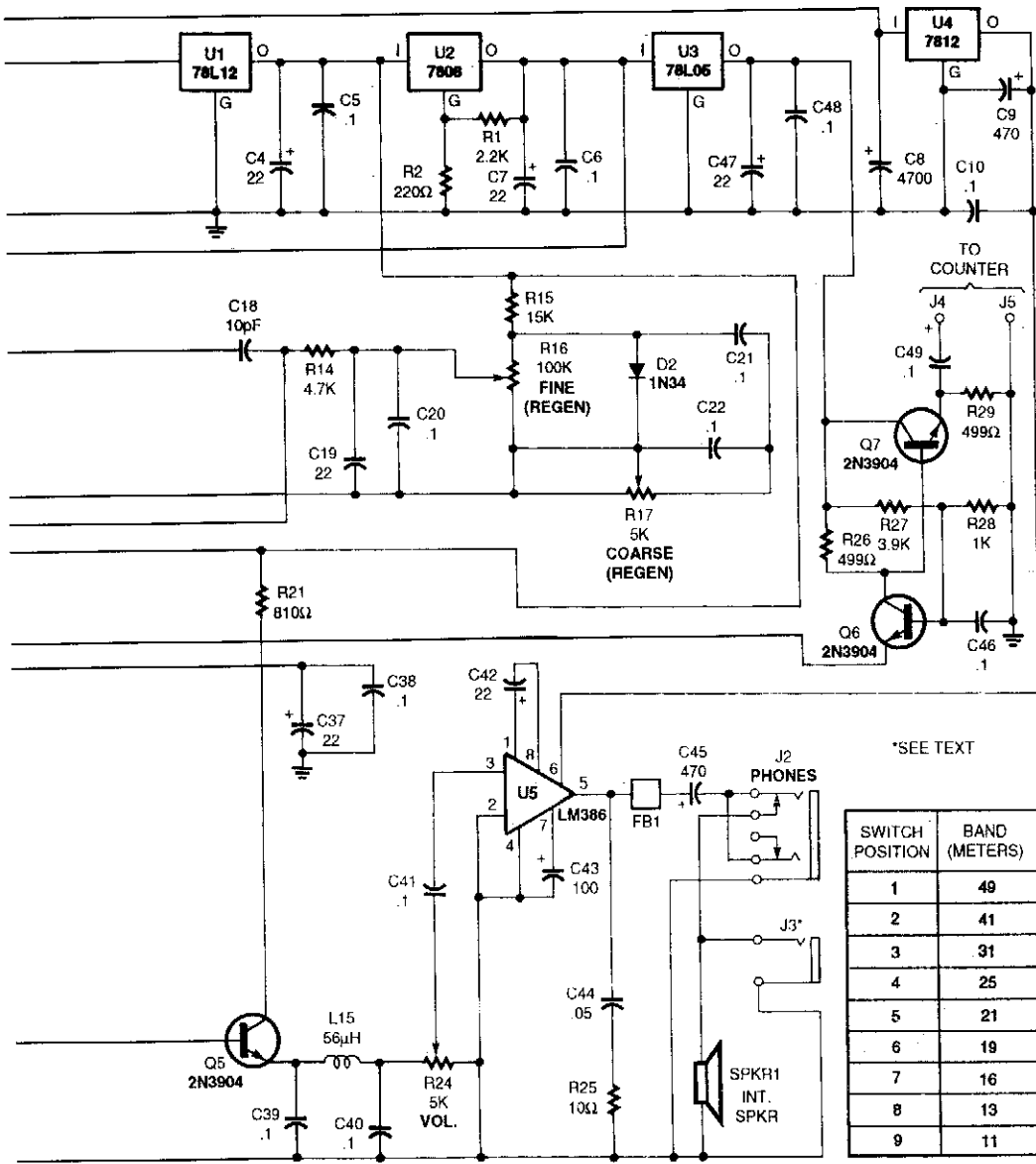

ONE-TUBE REGENERATIVE SW RECEIVER

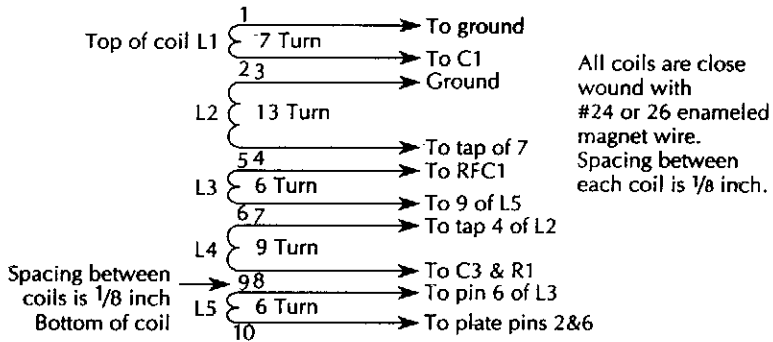
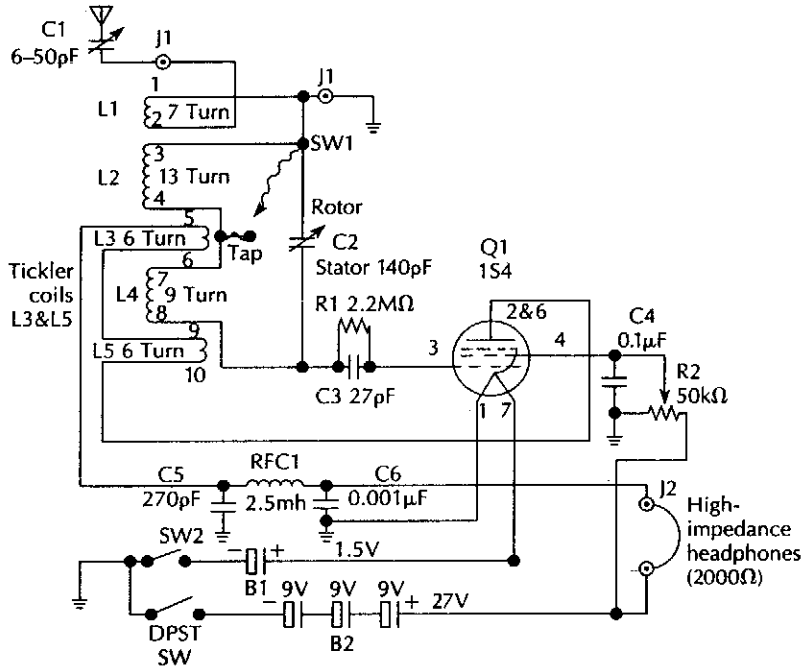

How to wind L1, L2, and L3 with taps. This receiver tunes in the 40- and 80-meter range of frequencies.

A 154 tube is used in a regenerative detector circuit. Details for coils are shown and frequency range can be shifted within 1.5 to 20 MHz by proportionally adjusting the number of turns on coils.

ONE-TUBE REGENERATIVE AM RECEIVER

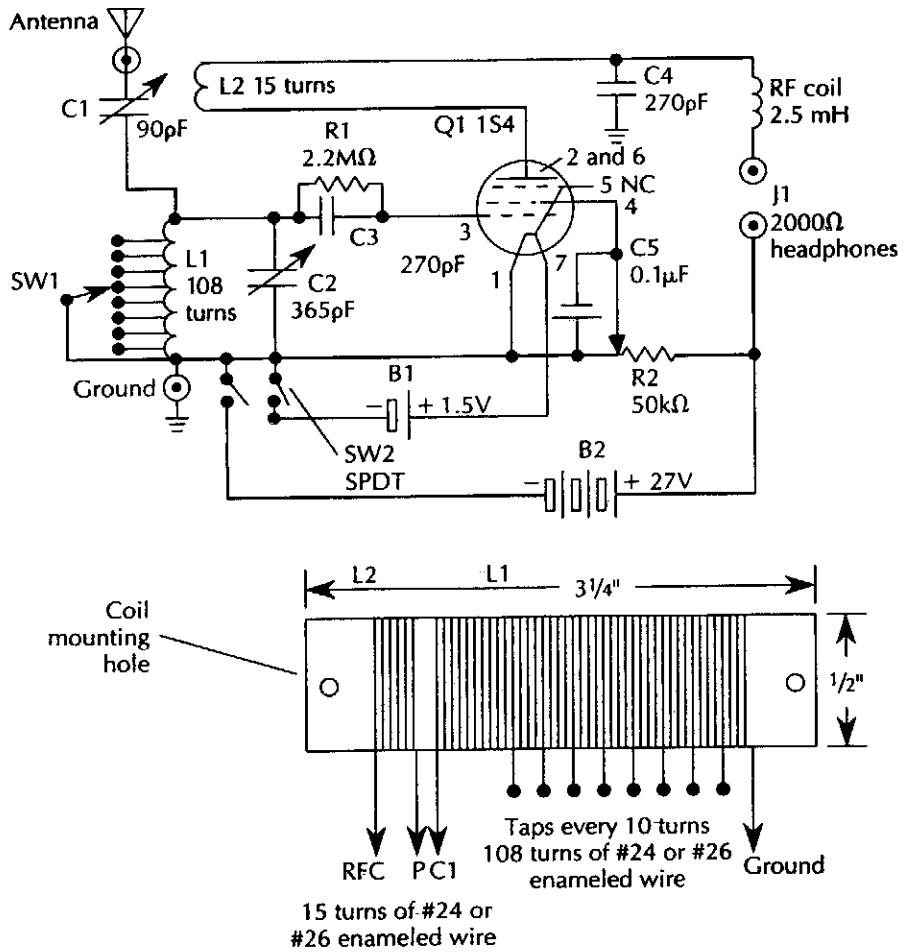

Wind both coils on PVC pipe using either #24 or #26 enameled wire. For coil L1, wind 108 turns on the pipe, and tap every 10 turns.

McGRAW-HILL

Fig. 76-11

Suitable for AM reception and as a simple radio project, this circuit uses a single tube as a regenerative detector.

TWO-BAND RADIO

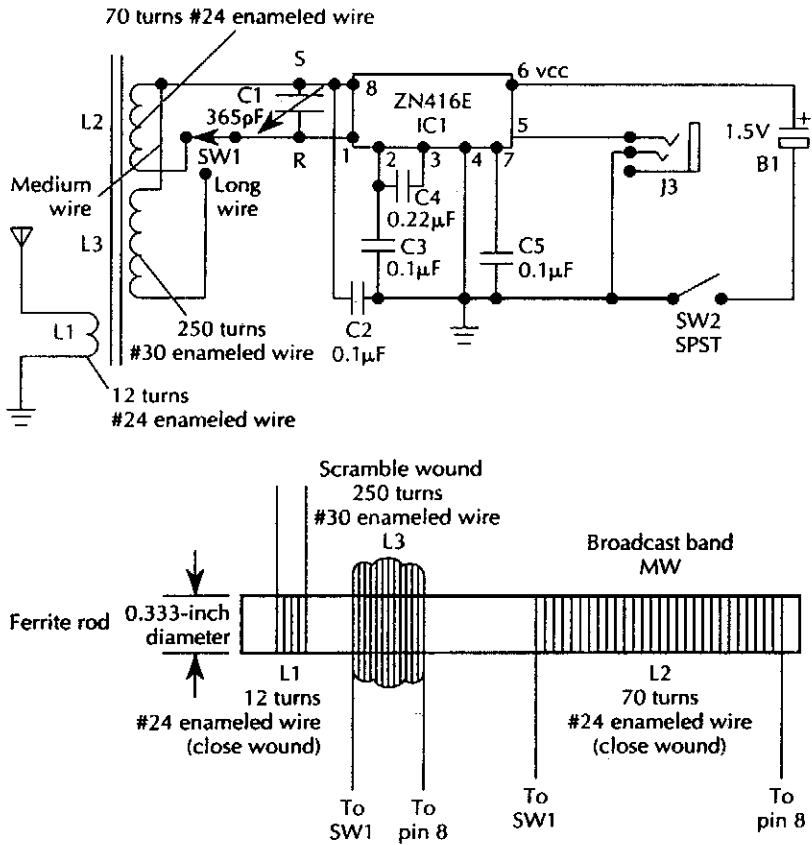

All three coil windings are wound on one long ferrite form. Two different coils are switched into the circuit, covering the longwave (lw) and medium-wave (mw) broadcast band.

McGRAW-HILL

Fig. 76-12

This TRF receiver covers the AM broadcast band and longwave bands (used in Europe and Asia for broadcasting). A loop antenna is used for reception and an external antenna can be connected. Frequency coverage is 150 to 1600 kHz.

SIMPLE CRYSTAL RADIO

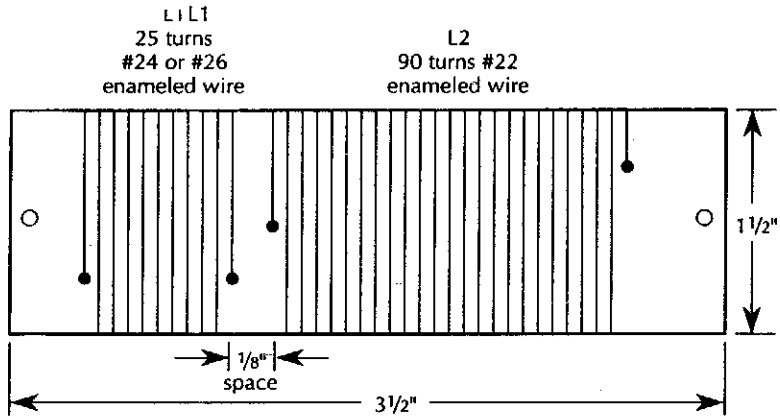
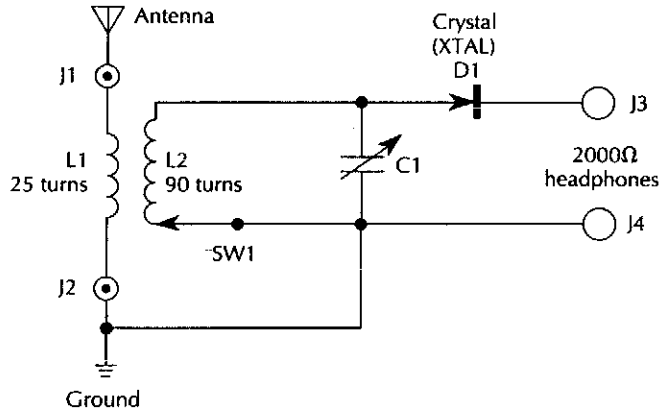

Wind 90 turns or 2½ inches of #22 enameled wire for L2, and 25 turns of #24 or #26 enameled wire for L1 on a 1½-inch PVC plastic pipe form.

McGRAW-HILL

Fig. 76-13

An IN34A (D1) is used as a detector in this crystal radio. A good outdoor antenna should be used.

VIDEO LINE RECEIVER

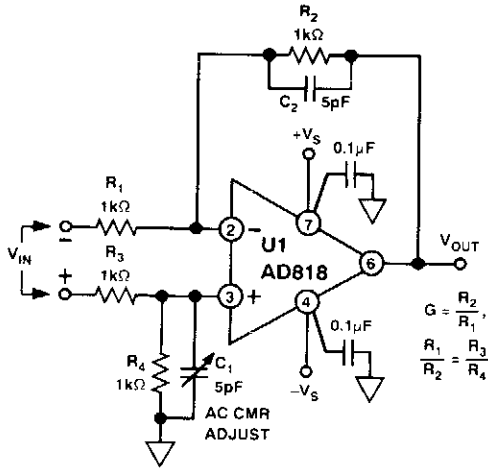

This circuit can achieve 46-dB common-mode rejection if R_1 , R_2 , R_3 , and R_4 are matched to 1%. C_1 is adjusted for best CMR above 1 MHz.

ANALOG DEVICES

Fig. 76-14

TWO-CHIP AM RECEIVER

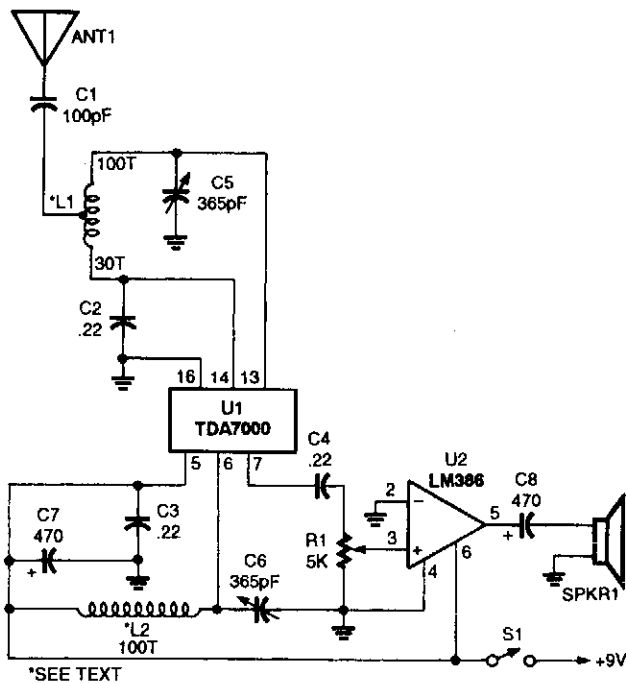

POPULAR ELECTRONICS

Fig. 76-15

This receiver is comprised of a TDA7000 single-chip FM receiver (U1), an LM386 low-voltage audio-power amplifier (U2), a pair of hand-wound coils (L1 and L2), and a few additional components. L1 and L2 are 100 turns of #28 wire on toroidal cores (about 240 μ H each). L1 is tapped at 30 turns.

RELAY INTERFACE TO RC RECEIVERS

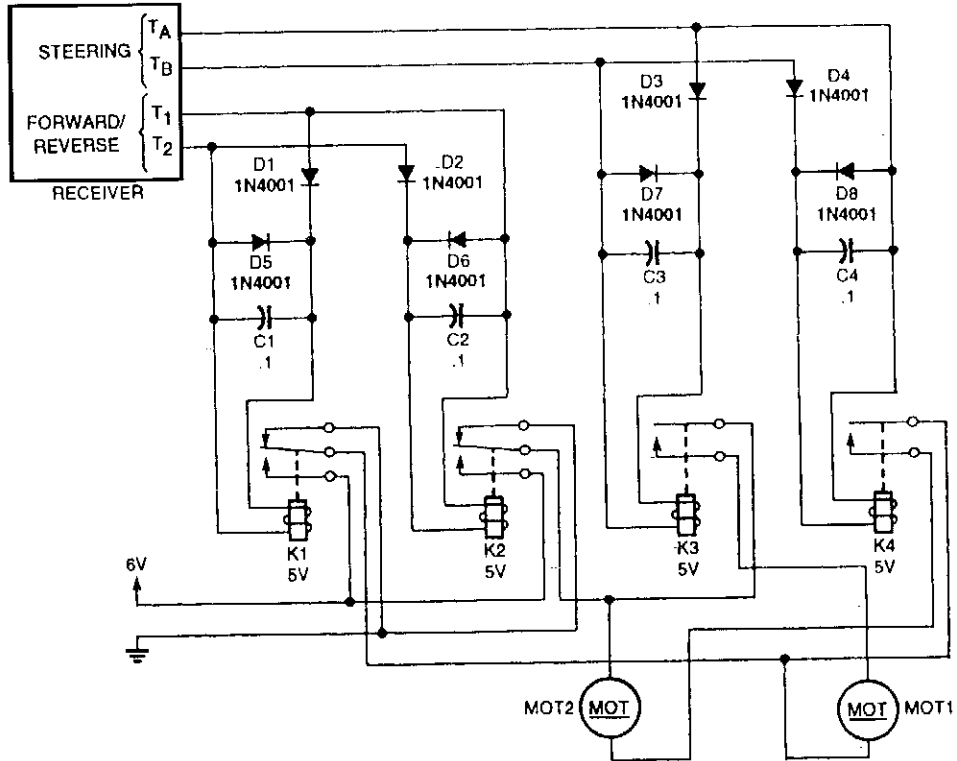

POPULAR ELECTRONICS

Fig. 76-16

You can add relays to some inexpensive RC receivers to operate your own chassis.

BASIC REGENERATIVE RECEIVER

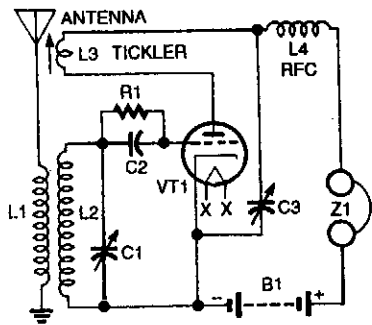

ELECTRONICS NOW

Fig. 76-17

SIMPLE RADIO RECEIVER

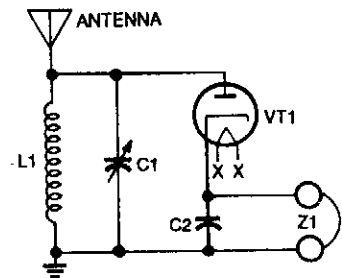

ELECTRONICS NOW

Fig. 76-18

Vacuum-tube detector receiver.

ONE-TUBE AM RECEIVER

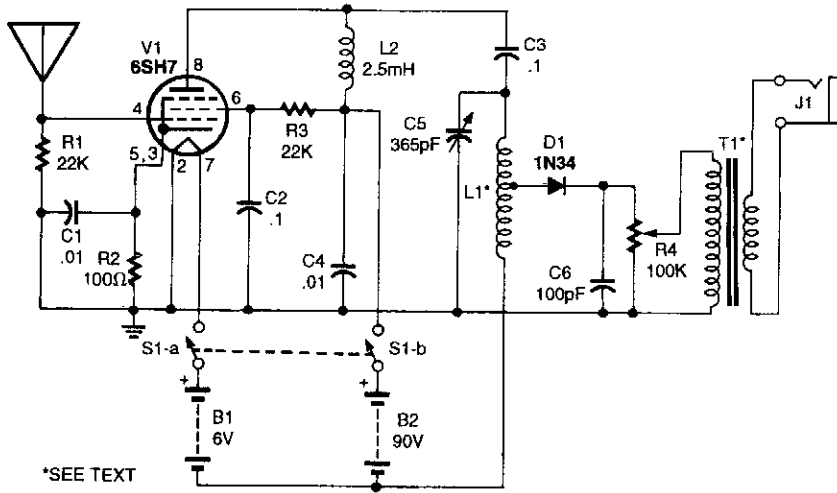

POPULAR ELECTRONICS

Fig. 76-19

This radio uses an untuned RF stage to boost the signal voltage up to the linear portion of the crystal diode's characteristic curve. The circuit's distortion and wide bandpass and a good-quality transformer make for a great-sounding AM radio. L1 is a winding of #22 enamelled wire 2" long on a 2" diameter plastic pipe. T1 is a tube-type radio output transformer, rated at 2000 Ω to the speaker voice coil.

BALANCED LINE RECEIVER

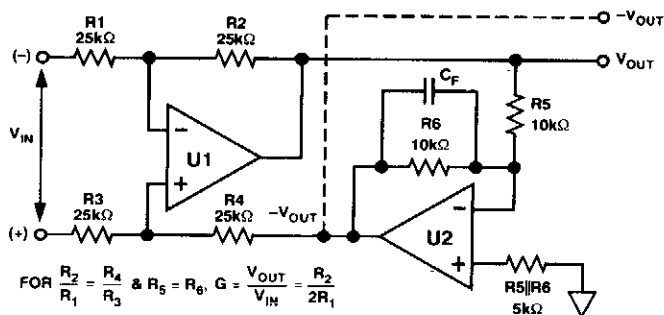

ANALOG DEVICES

Fig. 76-20

Unity-gain inverter U2 drives R4 (usually grounded at $-V_{\text{OUT}}$), equalizing currents in \pm input legs, and provides a choice of balanced p-p output with a gain of R_2/R_1 .

SUPERHET FRONT END

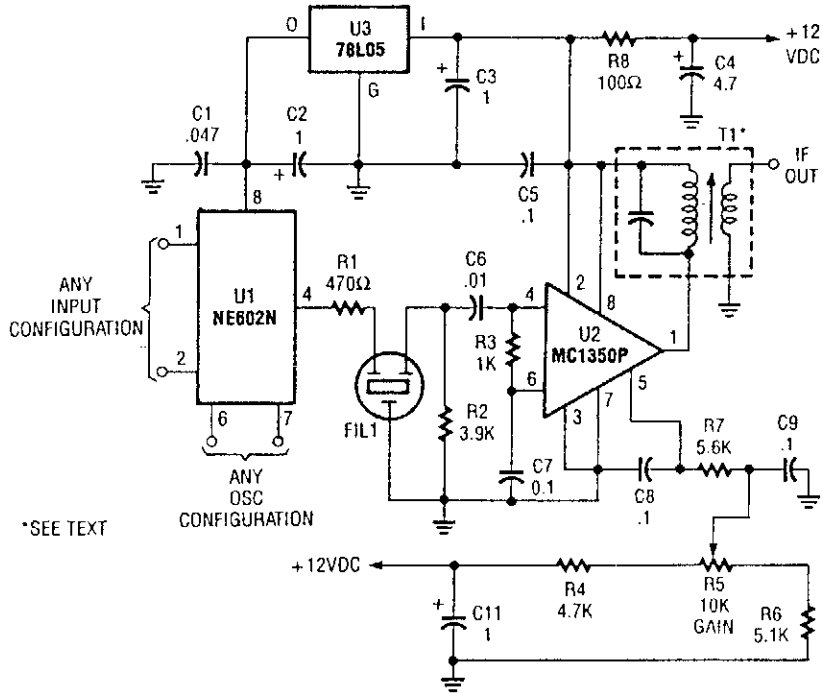

RADIO CRAFT

Fig. 76-21

This superhet receiver front end is simple and uses an NE602 followed by an MC1350 IF amplifier.

RECEIVER PREAMP

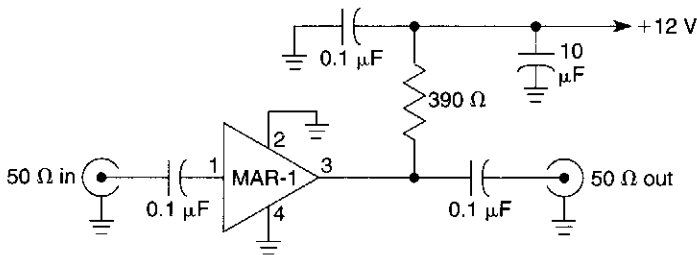

Freq. range 0.5-500 MHz
Power gain $G_p = 17$ dB @ 50 MHz

WILLIAM SHEETS

Fig. 76-22

Suitable for HF and VHF receivers, this preamplifier can be mounted on the back of the receiver for a boost in gain. Useful gain is about 17 dB at 50 MHz.

REGENERATIVE RECEIVER FOR 6 TO 17 MHz

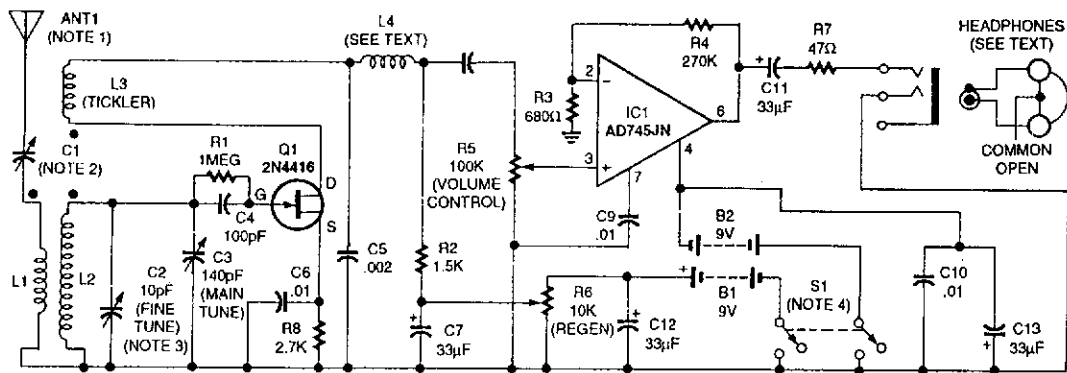

- NOTES:
1. ANTENNA: 100FT COPPER WIRE
 2. ADJUST C1 FOR ANTENNA USED
 3. C2 OPTIONAL (SEE TEXT)
 4. S1- DUAL ON OFF SWITCH.
 5. FOR COIL-WINDING DIRECTIONS SEE FIG. 9-a

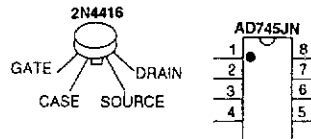

- NOTES:
1. ALL WINDINGS ARE NO.22 INSULATED STRANDED COPPER HOOKUP WIRE
 2. 1/2 -IN. OD PVC PIPE

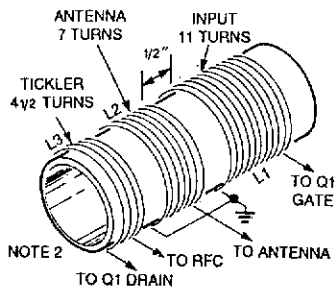

ELECTRONICS NOW!

Fig. 76-23

The headphones are 32-Ω stereo types. The common lead is left floating so that the two sides are in series, giving 64 Ω.

TWO-STAGE TRF REGENERATIVE RECEIVER

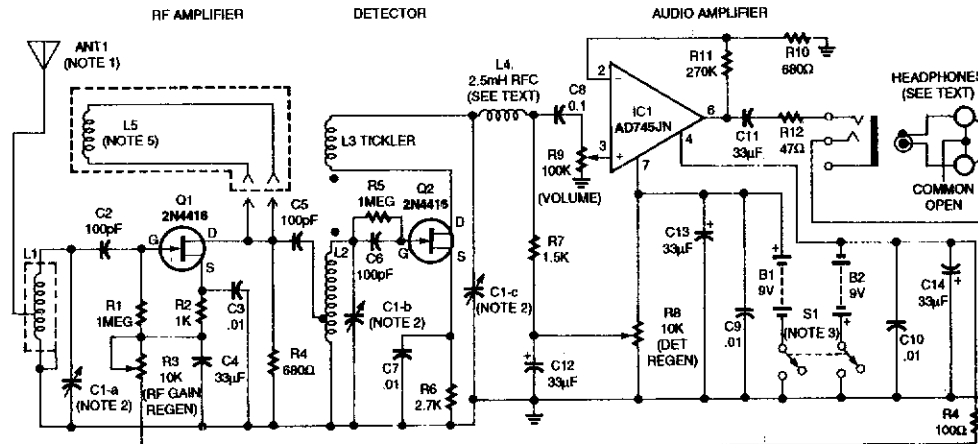

- NOTES:
1. ANT 1 IS 100-FT COPPER WIRE
 2. C1 IS 3-SECTION GANGED VARIABLE: 10 TO 365pF EACH SECTION
 3. S1 IS DUAL GANGED SWITCH
 4. FOR COIL-WINDING DIRECTIONS SEE FIG. 9
 5. MODIFICATION FOR 2 CASCADED REGENERATIVE STAGES (SEE TEXT)

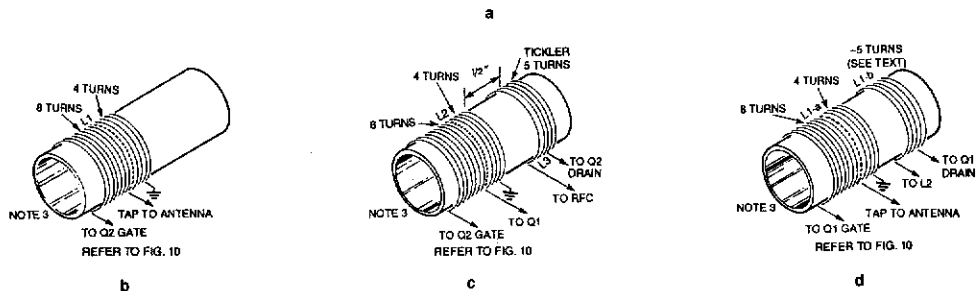
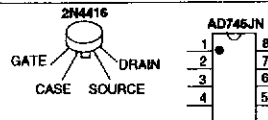

- NOTES:
1. ALL WINDINGS ARE NO 22 INSULATED STRANDED COPPER HOOKUP WIRE
 2. 1-IN. OD PLASTIC PILL BOTTLE OR
 3. 1-IN. OD PVC PIPE

ELECTRONICS NOW

This regenerative receiver uses a tuned RF stage to improve performance. The coil in Fig. 76-24D is for the purpose of adding a second regenerative stage (RF amp). This coil is L5 in the schematic.

Fig. 76-24

ECONOMY SHORTWAVE RECEIVER

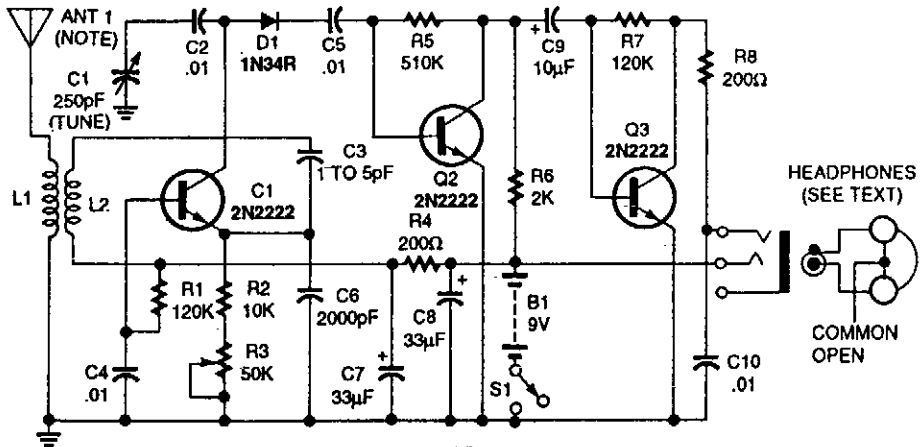

1. ANT 1 IS 100-FT COPPER WIRE.
 NOTES: 2 FOR COIL WINDING
 DIRECTIONS SEE FIG. 9

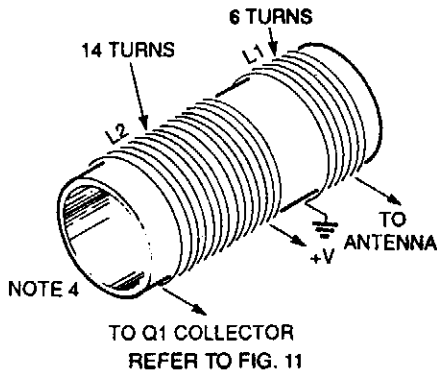

NOTES:

1. ALL WINDINGS ARE NO.22 INSULATED STRANDED COPPER HOOKUP WIRE
2. 1-IN. OD PLASTIC PILL BOTTLE
3. 1-IN. OD PVC PIPE OR NOTE 3

Using three transistors, this receiver covers the range of 6 to 17 MHz. Coils can be altered to change the range to a lower or higher frequency.

VARIOMETER-TUNED RADIO

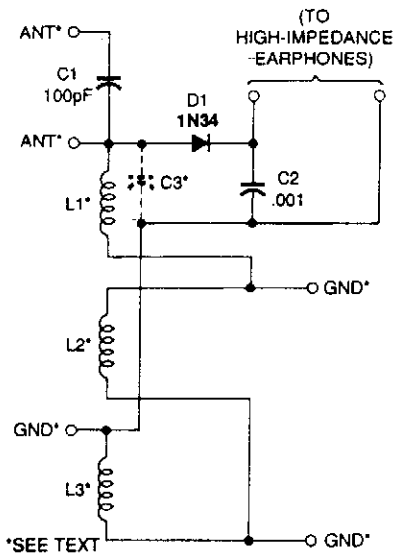

The two fixed coils of the variometer, L1 and L3, are wound on an 8½-inch-long piece of 1-inch-diameter plastic pipe (its outer diameter is about 1¼ inches). Each coil is 2¼ inches long. The number of turns is not critical, but 86 tightly wound turns of #22 enameled wire were used. When winding the coils, make sure you start at a point that will allow them to be placed 2 inches apart on the pipe. Drill holes in the pipe and run the leads of the coils out the end of the pipe that is closest to each.

The movable coil, L2, is wound on a piece of 1½-inch plastic pipe (its outer diameter is about 1¼ inches). The winding is 2 inches long. Like L1 and L3, the actual number of windings of this coil are not critical, as long as the winding is approximately the right length.

POPULAR ELECTRONICS

Fig. 76-26

OLD-FASHIONED CRYSTAL RADIO

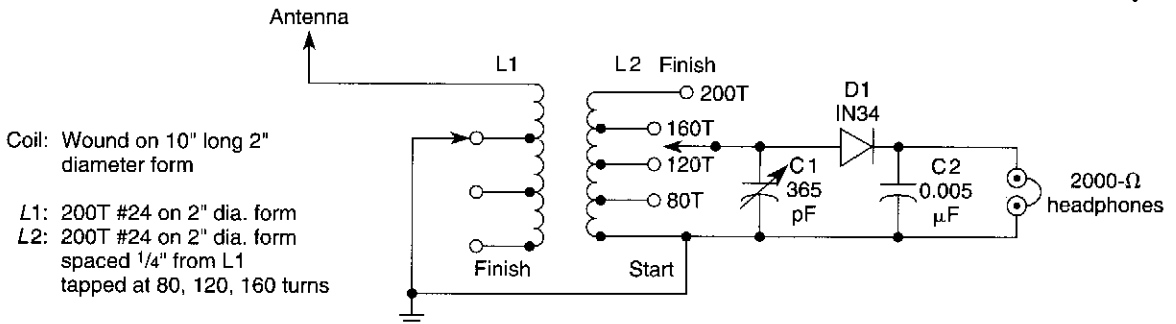

WILLIAM SHEETS

Fig. 76-27

L1 and L2 are wound on 4" diameter 10" form and are 200 turns of #24 wire. PVC pipe can be used.

WWV RECEIVER

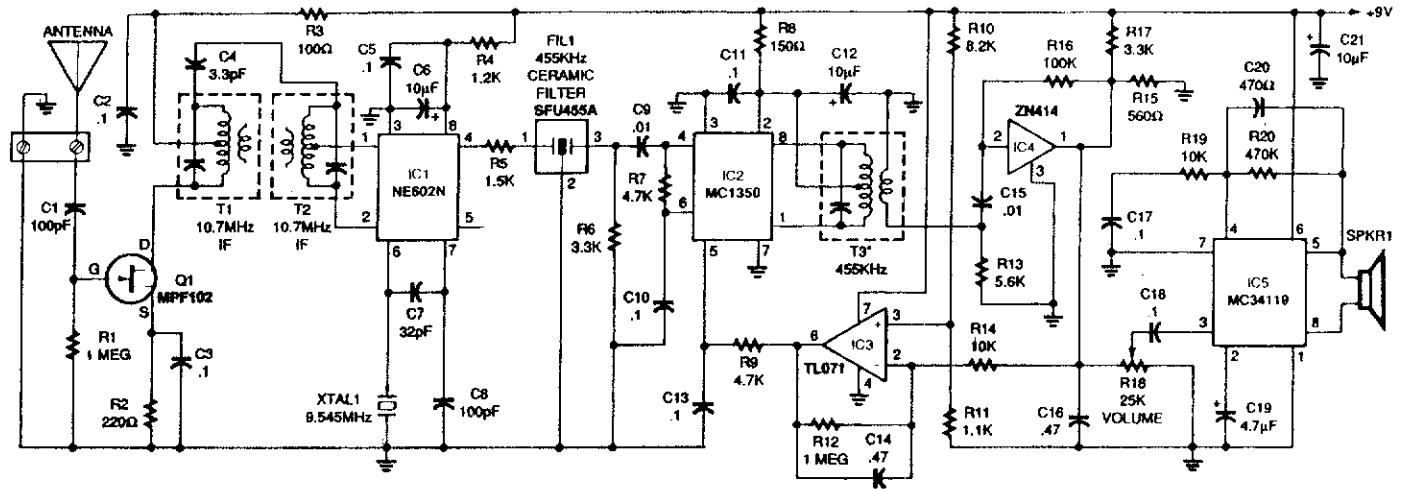

WWV and WWVH minute signals

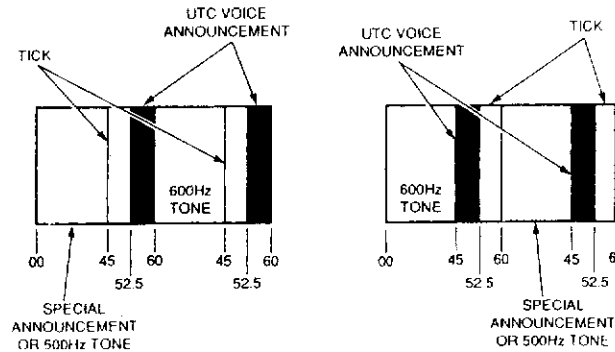

ELECTRONICS NOW

Fig. 76-28

This receiver for 10-MHz WWV signals uses a 10.7-MHz FM receiver IF transformers as front-end components. It is a super-het with a 455-kHz IF frequency. By changing the front-end components 5- or 15-MHz reception could be obtained. A 3- to 6-foot antenna is usually adequate.

77

Reference Circuits

The sources of the following circuits are contained in the Sources section, which begins on page 707. The figure number in the box of each circuit correlates to the entry in the Sources section.

Low-Voltage Reference
Positive Voltage Reference
Negative Voltage Reference

LOW-VOLTAGE REFERENCE

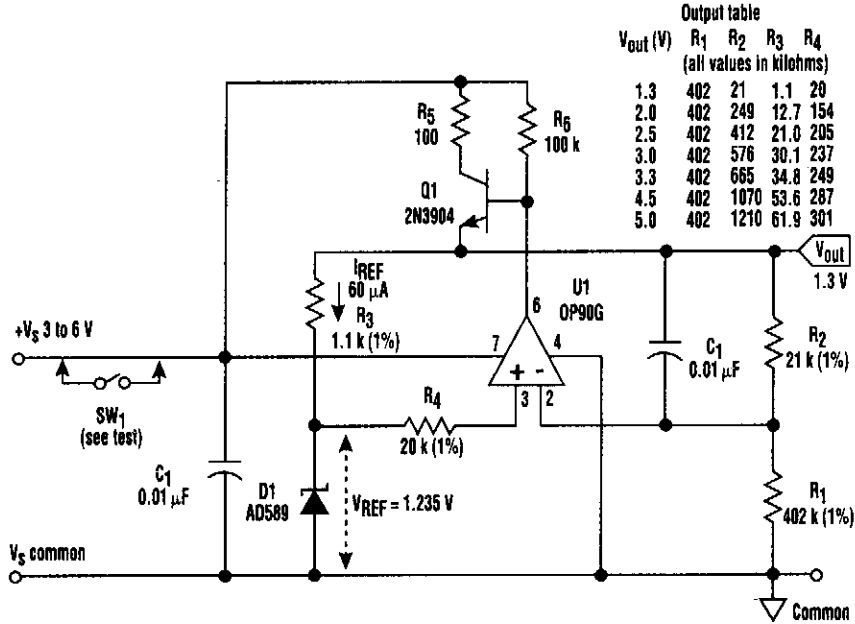

Fig. 77-1

ELECTRONIC DESIGN

This circuit illustrates a number of techniques that are useful for low-voltage, series-mode, power-efficient references. Intended for output currents of up to 10 mA, this design has an enabled standby current of about 100 μ A; it can be easily programmed over a wide range of output voltages.

POSITIVE VOLTAGE REFERENCE

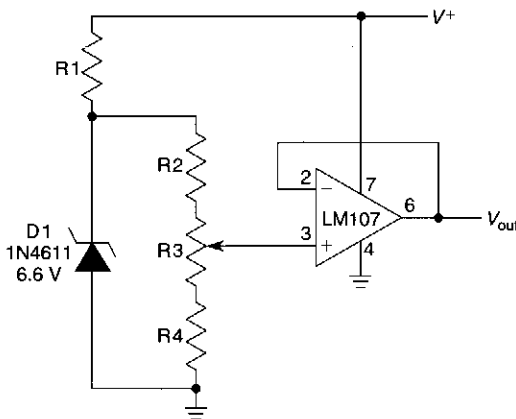

Fig. 77-2

NATIONAL SEMICONDUCTOR

D1 is used as a reference. R2, R3, and R4 provide desired output voltage to the op-amp voltage follower.

NEGATIVE VOLTAGE REFERENCE

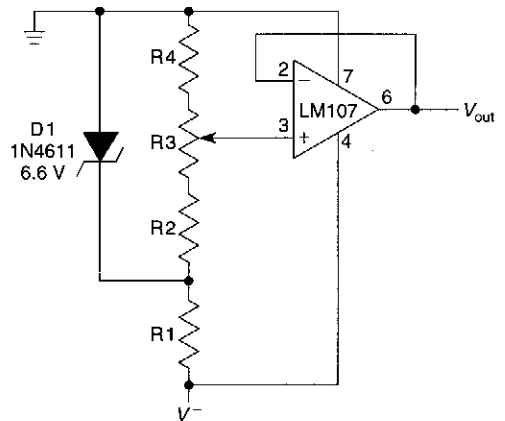

Fig. 77-3

NATIONAL SEMICONDUCTOR

D1 is used as a reference. R2, R3, and R4 are voltage dividers to obtain desired output voltage to the op-amp voltage follower.

78

Regulator Circuits

The sources of the following circuits are contained in the Sources section, which begins on page 707. The figure number in the box of each circuit correlates to the entry in the Sources section.

- 3.3-V 1-A Surface-Mount Regulator
- Logic Control of 78XX Regulator
- Low-Cost Step-Down Regulator
- Dual-Output Regulator
- Low-Noise Regulator (5 to 3.3 V)
- Reducing Ripple in a Switching Voltage Regulator
- Low-Dropout Three-Terminal Regulators for New Microprocessor Applications
- Low-Dropout Regulator
- Positive Regulator Sinks Current
- 5- to 3.3-V Surface-Mount Switching Regulator

3.3-V 1-A SURFACE-MOUNT REGULATOR

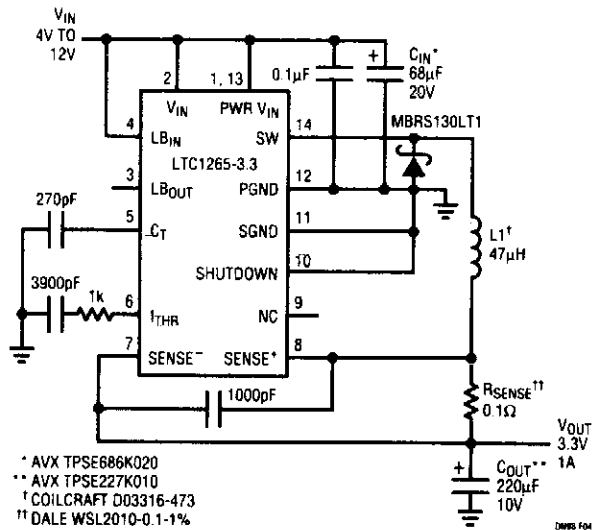

LINEAR TECHNOLOGY

Fig. 78-1

This figure shows a typical LTC1265 surface-mount application. It provides 3.3 V at 1 A from an input voltage range of 4 V to 12 V. The peak efficiency approaches 93% at mid-current levels.

LOGIC CONTROL OF 78XX REGULATOR

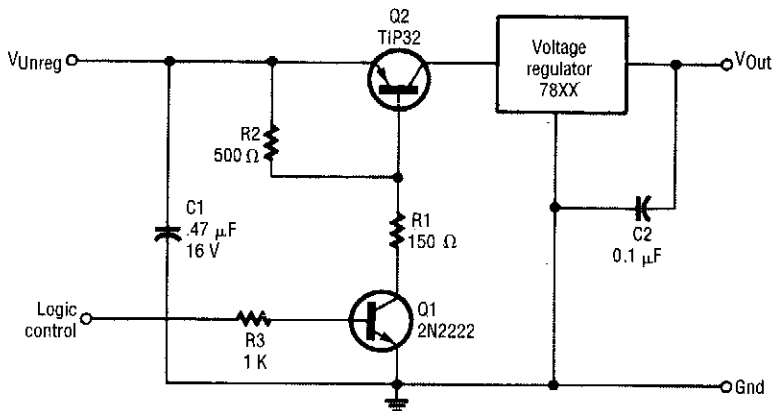

ELECTRONICS NOW

Fig. 78-2

Transistors can be used to control any 78xx series regulator with logic signals. Both transistors are controlled by the logic level present at the base of Q1.

LOW-COST STEP-DOWN REGULATOR

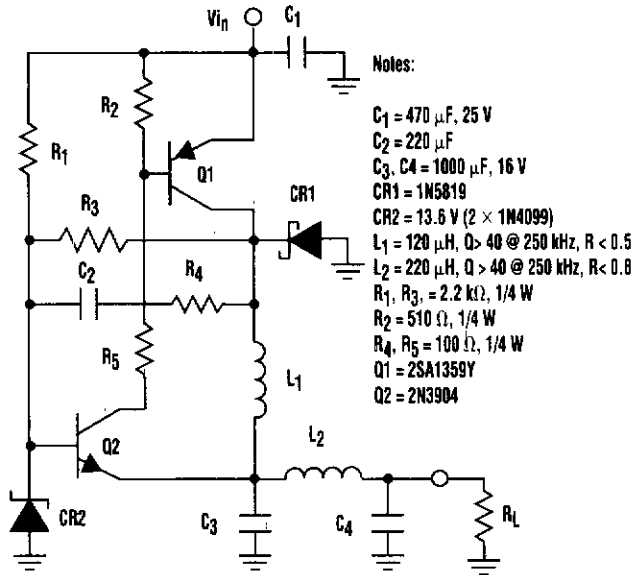

Input = 18.0 V, Output taken at C3				
Output (V)	Load (Ohm)	Ripple		Eff. (%)
		(mVpp)	(kHz)	
12.54	1k	50	4	87
12.52	90.9	25	112	86.5
12.49	47.6	40	58	88.9
12.45	24.4	70	31	91.8
Input = 18.0 V, Output taken at C4				
Output (V)	Load (Ohm)	Ripple		Eff. (%)
		(mVpp)	(kHz)	
12.53	1k	58	.08	67
12.46	90.9	1.5	—	86.5
12.37	47.6	1.5	—	88.4
12.20	24.4	1.5	—	90.4
Output taken at C3, Load = 24.4 Ohms				
Input (V)	Output (V)	Ripple		Eff. (%)
		(mVPP)	(kHz)	
15.0	12.35	73	17.8	93.4
18.0	12.45	70	31.0	91.8
21.0	12.53	75	43.3	90.8

ELECTRONIC DESIGN

Fig. 78-3

This inexpensive and efficient discrete step-down regulator is based on a complementary transistor arrangement that uses both positive and negative feedback and is referenced to a Zener diode. Inductor L1 is selected to maintain the switching frequency above the audible range for the intended operating load. The output filter L2 and C4 reduces ripple to less than 10 mV p-p over a large range of loads, with only a slight decrease in efficiency.

DUAL-OUTPUT REGULATOR

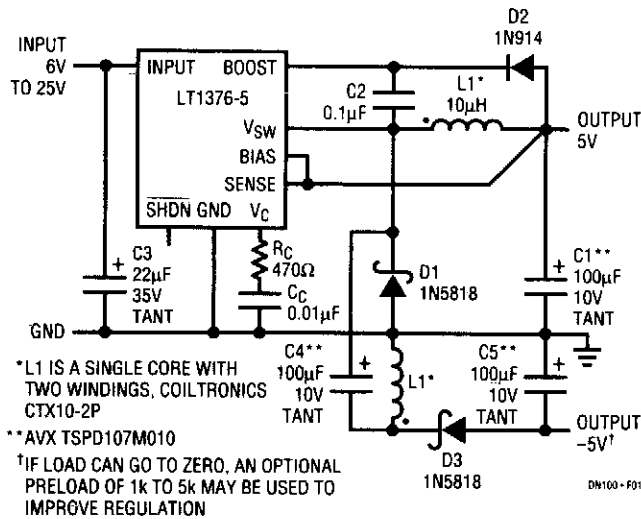

LINEAR TECHNOLOGY

Fig. 78-4

If load can go to zero, an optional preload of 1 to 5 k Ω can be used to improve regulation. Many modern circuit designs still need a dual polarity supply. Communication and data acquisition are typical areas where both 5 V and -5 V are needed for some of the IC chips.

The current mode architecture and saturating switch design allow the LT1376 to deliver up to 1.5-A load current from the 8-pin SO package. L1 is a 10- μ H surface-mount inductor from Coiltronics. The second winding is used to create a negative-output SEPIC (Single-Ended Primary Inductance Converter) topology using D3, C4, C5, and the second half of F1. This converter takes advantage of the fact that the switching signal driving L1 as a positive buck converter is already the correct amplitude for driving a -5-V SEPIC converter. During switch-off time, the voltage across L is equal to the 5-V output plus the forward voltage of D1. An identical voltage is generated in the second winding, which is connected to generate -5 V using D3 and C5. Without C4, this would be a simple flyback winding connection with modest regulation. The addition of C4 creates the SEPIC topology. Note that the voltages swing at both ends of C4 is theoretically identical—even without the capacitor. The undotted end of both windings goes to a zero ac voltage node, so the equal windings will have equal voltages at the opposing ends. Unfortunately, coupling between windings is never perfect, and load regulation at the negative output suffers as a result. The addition of C4 forces the winding potentials to be equal and gives much better regulation.

LOW-NOISE REGULATOR (5 TO 3.3 V)

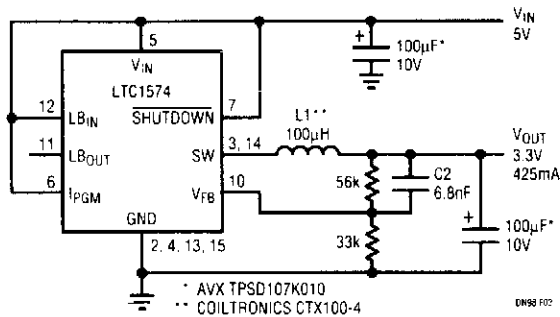

LINEAR TECHNOLOGY

Fig. 78-5

In some applications, it is important not to introduce any switching noise within the audio frequency range. To circumvent this problem, a feed-forward capacitor can be used to shift the noise spectrum up and out of the audio band with C2 being the feed-forward capacitor. The peak-to-peak output ripple is reduced to 30 mV over the entire load range. A toroidal surface mount inductor L1 is chosen for its excellent self-shielding properties.

REDUCING RIPPLE IN A SWITCHING VOLTAGE REGULATOR

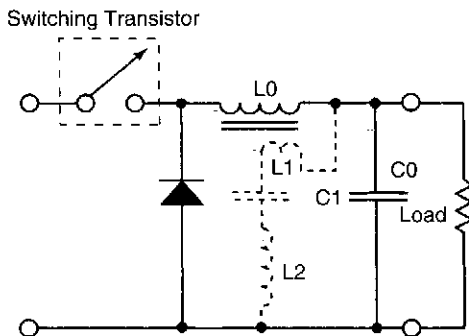

Simple additional circuitry that consists of relatively small components can reduce the output ripple by a factor of about 10. The additional components are indicated by the dashed lines.

A current opposing the ripple is injected into the filter capacitor. The essence of the present technique is to inject, into this capacitor, a current opposite to that which already flows into this capacitor. A small additional winding, L1, in inductor L0 provides transformer coupling to generate the current that opposes the original ripple current. The circuit from L1 through C0 is completed by a small additional external inductor L2 and coupling capacitor C1.

NASA TECH BRIEFS

Fig. 78-6

LOW-DROPOUT THREE-TERMINAL REGULATORS FOR NEW MICROPROCESSOR APPLICATIONS

**Recommended LT1584 Adjustable Circuit for
the Intel P54CT Microprocessor**

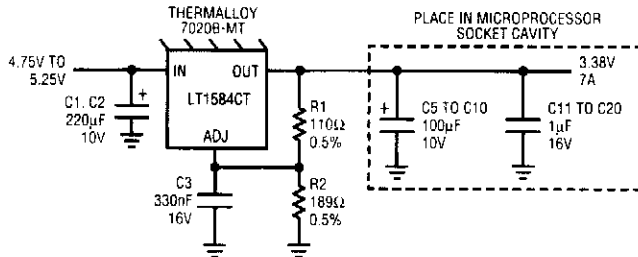

LINEAR TECHNOLOGY

Fig. 78-7

The LT1584/LT1585/LTL1587 are high-performance, low-dropout regulators designed to meet the demands of the newest high speed, low voltage microprocessors. These devices are designed to regulate from 5-V supplies to output voltages between 1.25 V and 3.6 V. The LT1584 can provide up to 7 A of current, making it ideal for powerful Pentium processor or similar applications. The LT1585 can supply up to 4 A, while the LT1587 supplies up to 3 A. The excellent transient response capability allows them to maintain good regulation even with significant load steps. Fixed 3.3 V, 3.45 V, 3.6 V and adjustable output voltages are available.

LOW-DROPOUT REGULATOR

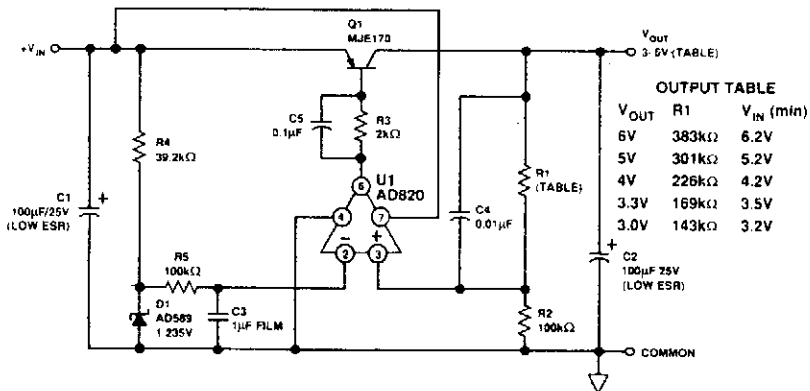

ELECTRONIC DESIGN

Fig. 78-8

This low-dropout reference produces a 4.5-V output from a supply just a few hundred mV greater. With 1-mA dc loading, it maintains a stable 4.5-V output for inputs down to 4.7 V.

POSITIVE REGULATOR SINKS CURRENT

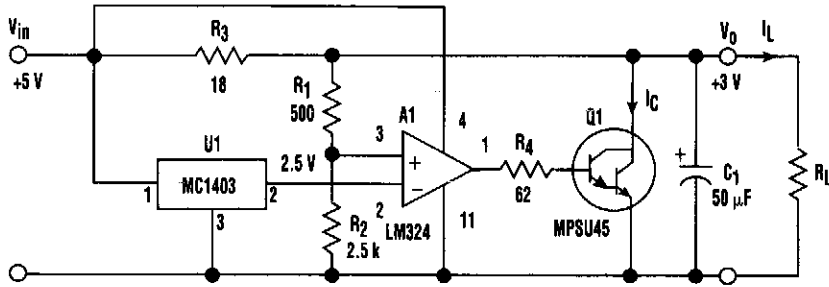

ELECTRONIC DESIGN

Fig. 78-9

Generally speaking, conventional positive voltage regulators can only source current; they can't sink it. However, the positive regulator shown breaks that rule because it can perform both functions. The idea is to have the control transistor Q1 in shunt so that the regulator can either source or sink current.

The circuit provides +3-V output from a +5-V supply. U1 is a bandgap reference that supplies a stable +2.5-V reference to the error amplifier (A1). The output voltage (V_O) is sampled by the resistor network (R_1 and R_2). If V_O were to increase, A1 will drive the base of Q1 harder, increasing the collector current (I_c).

This increases the drop across R_3 and V_O decreases, thus regulating the output voltage. The output voltage is given by $V_O = 2.5(1 + R_1/R_2)$.

Under no load conditions, Q1 draws 110 mA [$(V_{in} - V_O)/R_3$]. With a load connected, and as the regulator begins to source load current (I_L), I_c decreases to keep the drop across R_3 constant.

At $I_L = 100$ mA, Q1 carries 10 mA. If R_L is connected to the positive supply higher than V_O , then the regulator must sink current, and I_L becomes negative. At $I_L = -100$ mA, Q1 carries 210 mA while maintaining the output voltage at +3 V. The output voltage will remain constant at +3 V—even if the load current changes sign.

With the proper heatsink on Q1, the regulator can sink more than 300 mA. If a "sink only" option is desired, the dissipation in Q1 can be reduced by using a 180- Ω resistor for R_3 . R_4 limits the base current drive for Q1 and prevents the output of A1 from being clamped at $2 V_{BE}$.

5- TO 3.3-V SURFACE-MOUNT SWITCHING REGULATOR

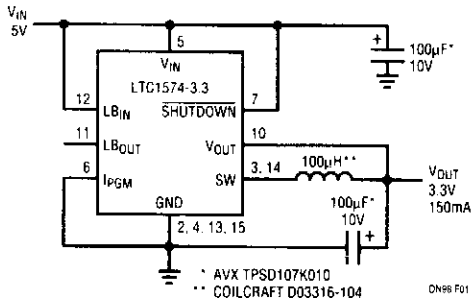

This converter provides 3.3 V at 150 mA from an input voltage of 5 V. Peak inductor current is limited to 340 mA by connecting pin 6 (I_{PGM}) to ground. For applications requiring higher output current, connect pin 6 to V_{in} . Under this condition, the maximum load current is increased to 425 mA.

LINEAR TECHNOLOGY

Fig. 78-10

79

Relay Circuits

The sources of the following circuits are contained in the Sources section, which begins on page 707. The figure number in the box of each circuit correlates to the entry in the Sources section.

Latching Relay Alarm Circuit
Momentary Relay Circuit
Latching Relay Driver for +12-V Loads
High-Impedance Relay Driver
Latching Relay Driver
Transistor Relay Driver
Fast Turn-On/Delayed-Off Relay Circuit
Low-Frequency Relay Oscillator

LATCHING RELAY ALARM CIRCUIT

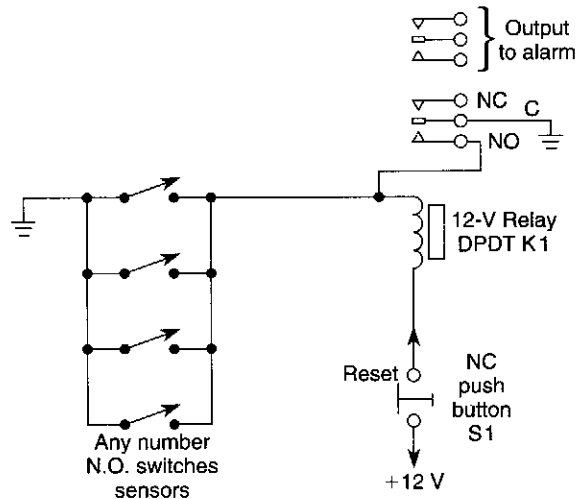

WILLIAM SHEETS

Fig. 79-1

Momentarily closing any sensors will cause K1 to latch. S1 must be depressed to reset circuit. If any sensor is still closed circuit will not reset.

MOMENTARY RELAY CIRCUIT

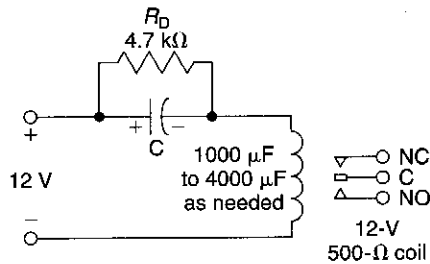

WILLIAM SHEETS

Fig. 79-2

The charging current of a capacitor can be used if a momentary relay-on circuit is needed. Depending on the relay characteristics, C will vary from 1000 to 4000 μF or so for a 1-s hold time if a 500- Ω relay is used. R_D discharges capacitor C to ready the circuit for the next operation. The value should be high enough so as not to maintain the relay closure at highest expected supply voltage.

LATCHING RELAY DRIVER FOR +12-V LOADS

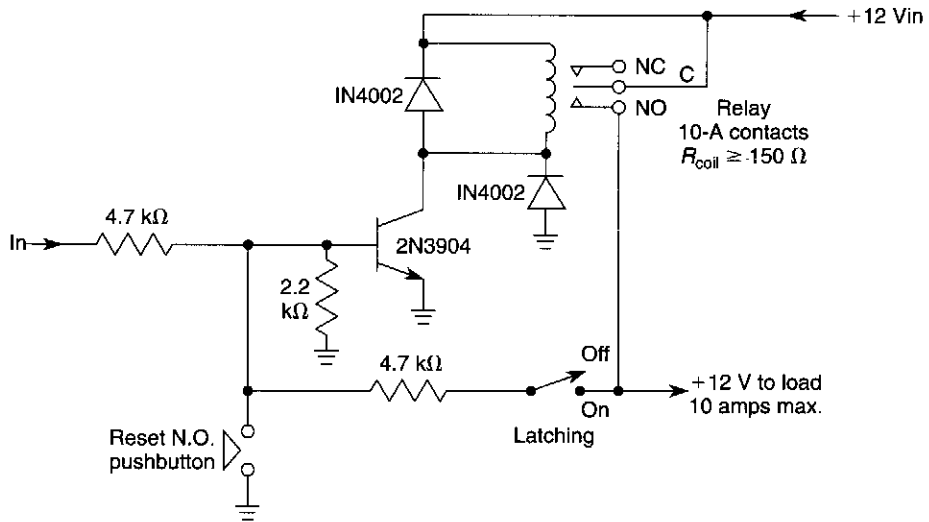

WILLIAM SHEETS

Fig. 79-3

A 4-V signal will cause the relay to pull in when Q1 turns on. Latching is obtained by feedback through a 4.7-k Ω resistor. A switch is used to select latching or nonlatching operation. A NO pushbutton releases the circuit.

HIGH-IMPEDANCE RELAY DRIVER

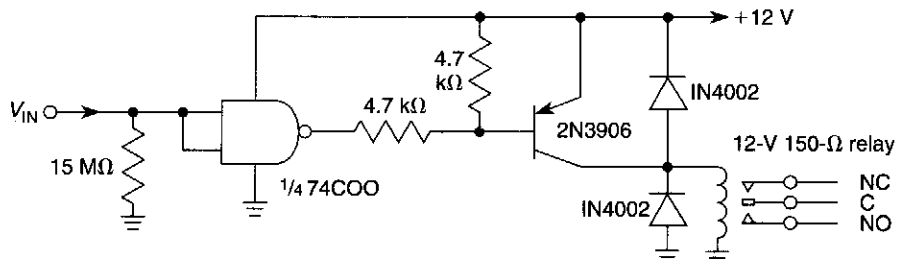

WILLIAM SHEETS

Fig. 79-4

A CMOS gate is used to drive a switching transistor and relay.

LATCHING RELAY DRIVER

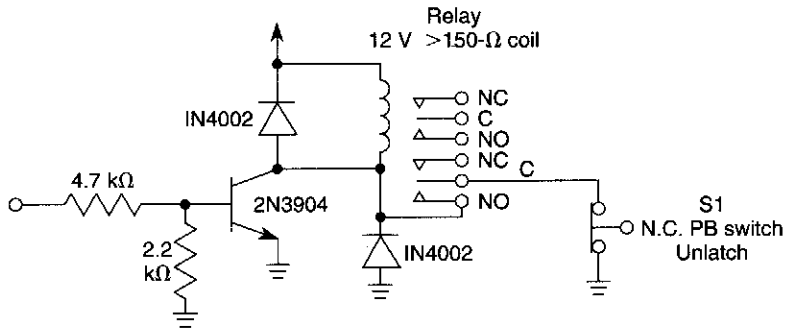

WILLIAM SHEETS

Fig. 79-5

An input of 4 V or greater will drive this circuit. When the relay pulls in, one pair of contacts is used to latch the relay closed. It will remain closed until S1 is pressed.

TRANSISTOR RELAY DRIVER

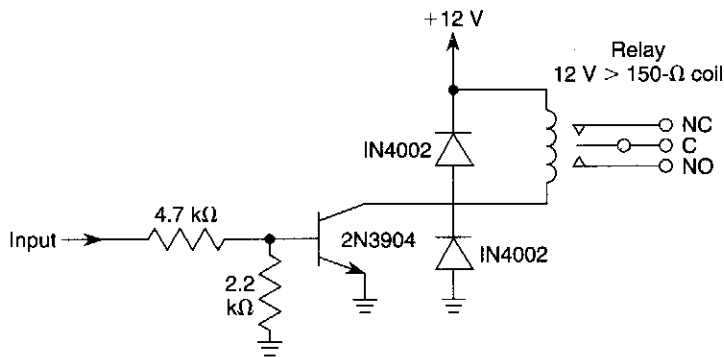

WILLIAM SHEETS

Fig. 79-6

An input of 4 V or greater will drive this relay circuit.

FAST TURN-ON/DELAYED-OFF RELAY CIRCUIT

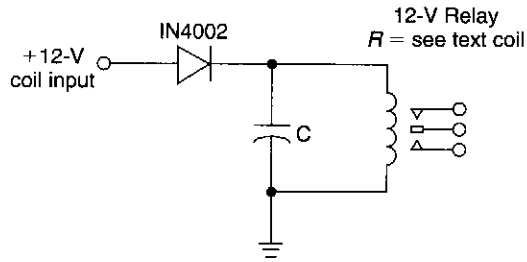

WILLIAM SHEETS

Fig. 79-7

C is a large capacitor that has a charge time of $R_{\text{supply}} C$, assuming $R_{\text{supply}} < R_{\text{coil}}$. The discharge time will be $R_{\text{coil}} C$ neglecting relay coil inductance. With $C = 10,000 \mu\text{F}$ and $R_{\text{coil}} = 500 \Omega$, a release time constant of 5 seconds might be obtained. Many relays will hold in until the coil current decays to 25% of the pull-in current so that the actual time constant depends on the relay holding current.

LOW-FREQUENCY RELAY OSCILLATOR

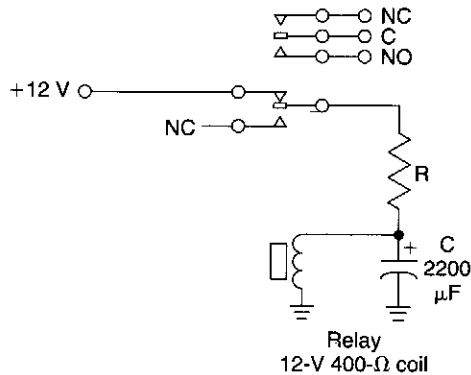

WILLIAM SHEETS

Fig. 79-8

Depending on the value of C and the resistance of the relay coil, and the difference in pull-in and drop-out voltage, this circuit will oscillate at a low frequency. R limits inrush current to capacitor C to a level that the relay contacts can handle. Typically, for a 400- Ω relay, R can be 20 to 440 ohms. Flash rate is approximately 1 cycle/second, depending on the relay.

80

Sample-and-Hold Circuits

The sources of the following circuits are contained in the Sources section, which begins on page 707. The figure number in the box of each circuit correlates to the entry in the Sources section.

Micropower 4-Channel Sample-and-Hold Circuit
Low-Drift Sample and Hold

MICROPOWER 4-CHANNEL SAMPLE-AND-HOLD CIRCUIT

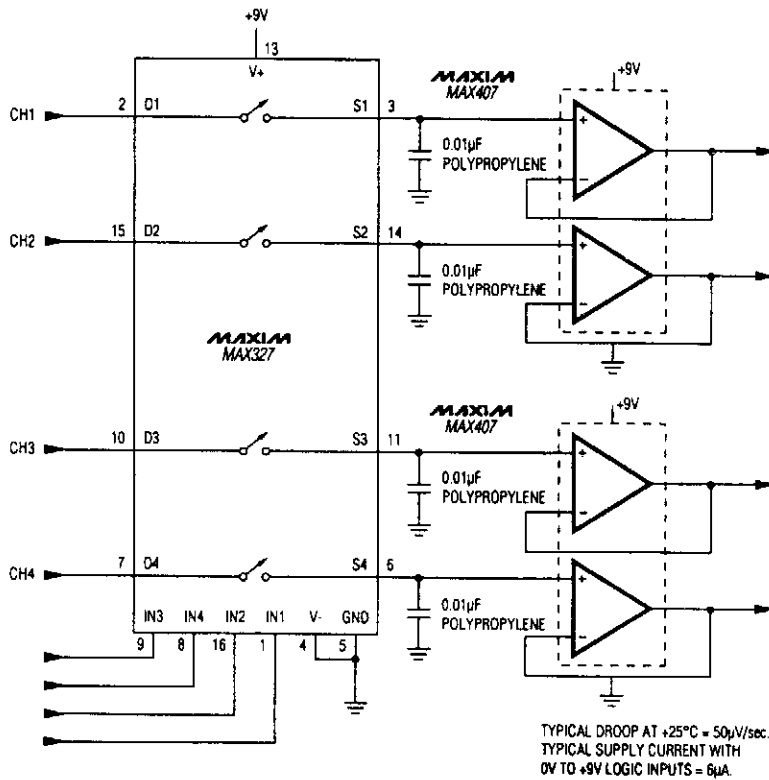

MAXIM

Fig. 80-1

Three Maxim ICs make up this sample-and-hold circuit. The supply current is only 6 µA.

LOW-DRIFT SAMPLE AND HOLD

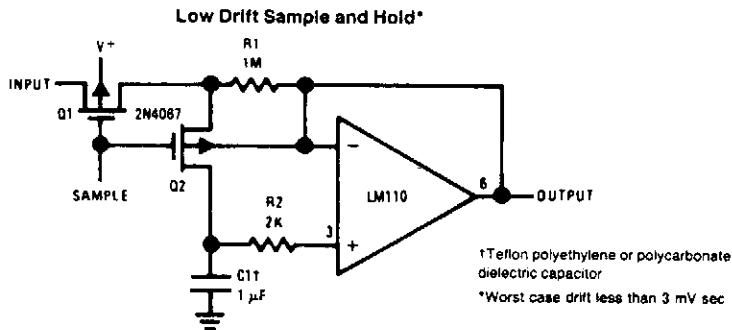

NATIONAL SEMICONDUCTOR

Fig. 80-2

81

Sawtooth Generator Circuits

The sources of the following circuits are contained in the Sources section, which begins on page 707. The figure number in the box of each circuit correlates to the entry in the Sources section.

Op-Amp Linear Sawtooth Generator
Sawtooth Generator

OP-AMP LINEAR SAWTOOTH GENERATOR

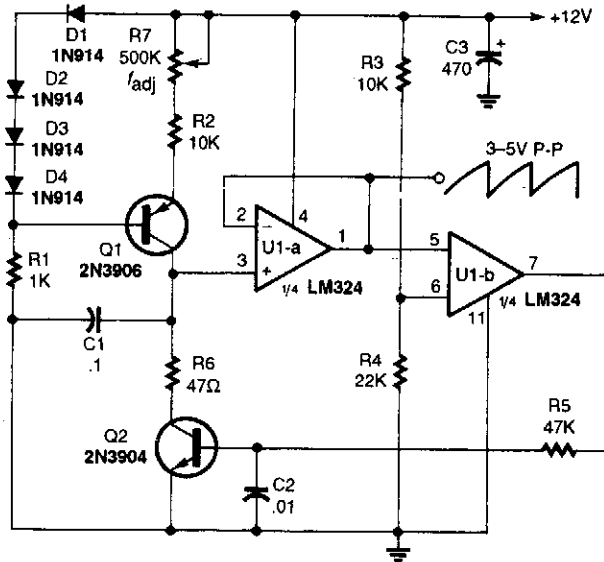

POPULAR ELECTRONICS

Fig. 81-1

Q1 is connected in a simple constant-current generator circuit. The value of Q1's emitter resistor sets the constant-current level flowing from the transistor's collector to the charging capacitor, C1.

One op amp of an LM324 quad op-amp IC, U1-a, is connected in a voltage-follower circuit. The input impedance on the voltage follower is very high and offers little or no load on the charging circuit. The follower's output is connected to the input of U1-b, which is configured as a voltage comparator. The comparator's other input is tied to a voltage-divider setting the input level to about 8 V.

The output of U1-b at pin 7 switches high when the voltage at its positive input, pin 5, goes above 8 V. That turns on Q2, discharging C1. The sawtooth cycle is repeated over and over as long as power is applied to the circuit.

The sawtooth's frequency is determined by the value of C_1 and the charging current supplied to that capacitor. As the charging current increases, the frequency also increases, and vice versa. To increase the generator's frequency range, decrease the value of C_1 , and to lower the frequency, increase the value of C_1 . The output is about 3 to 5 V.

SAWTOOTH GENERATOR

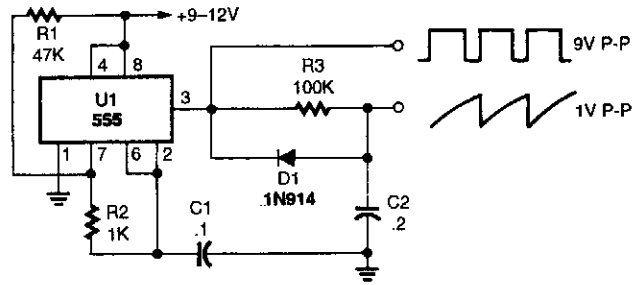

POPULAR ELECTRONICS

Fig. 81-2

A sawtooth waveform generator circuit using a 555 IC is shown. The IC is connected in an astable oscillator circuit with the majority of the output contained in the positive portion of the cycle. The negative output is a very brief pulse.

Capacitor C2 charges through R3 in a positive direction during the time that the IC's output (at pin 3) is high. When the output goes negative, C2 is rapidly discharged through D1 and the IC's output.

Peak-to-peak sawtooth output is about 1 V. The linearity of this circuit is best when R3 is as large as possible. The oscillator's frequency is about 200 Hz and can be increased by lowering either the value of R₁ or C₁; to decrease the frequency, increase the values of those components.

82

Scanner Circuits

The sources of the following circuits are contained in the Sources section, which begins on page 707. The figure number in the box of each circuit correlates to the entry in the Sources section.

FM Scanner Noise Squelch
Scanner Silencer
Shortwave Converters for Scanners

FM SCANNER NOISE SQUELCH

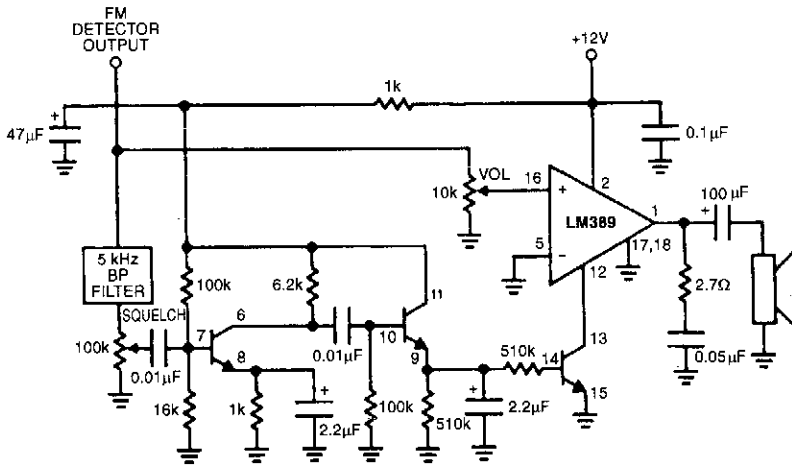

NATIONAL SEMICONDUCTOR

Fig. 82-1

The LM389 is operated in the cut-off mode with pin 12 grounded via one of the internal transistors. A sample of detected noise is taken through a 5-kHz filter. Upon reception of signal, the detector output quiets, and noise level drops. This increases impedance at pin 12 of the LM389, causing audio to be passed. The three transistors are part of the LM389.

SCANNER SILENCER

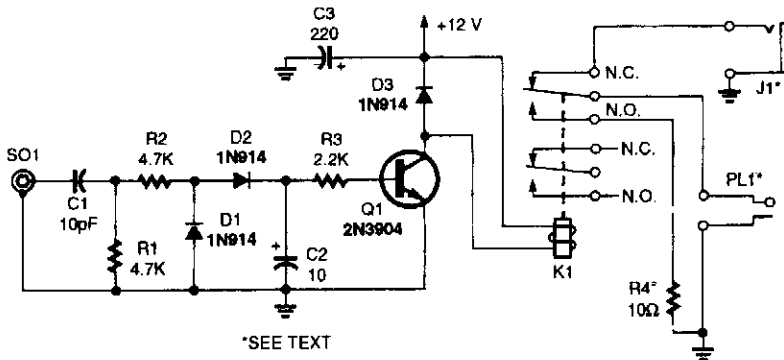

*SEE TEXT

POPULAR ELECTRONICS

Fig. 82-2

When a scanner is used at amateur radio or CB stations, the scanner sometimes picks up transmitted signal and howls or squeals. When RF is detected, Q1 turns on, energizing K1 and disconnecting the scanner speakers. SO1 is connected to the transmit antenna lead via a tee fitting. C1 is optimum for 5- to 10-W 30-MHz use. For higher power or higher frequencies, reduce C1 to as low as needed. If C1 is so small as to be impractical, R1 can be shunted with a 10- or 22-pF capacitor, as needed.

SHORTWAVE CONVERTERS FOR SCANNERS

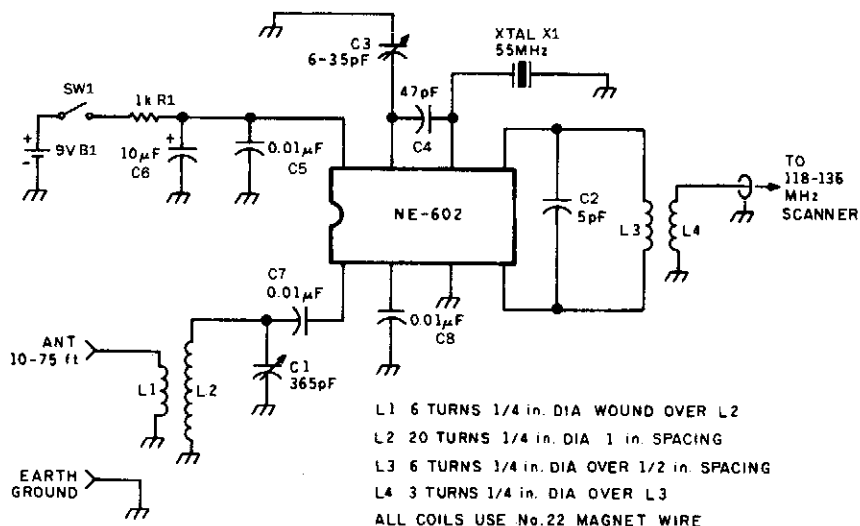

73 AMATEUR RADIO TODAY

Fig. 82-3

The AM aircraft band at 118 to 136 MHz is used in this converter design as an IF output. The second harmonic of the 55-MHz crystal (110 MHz) mixes with the shortwave input of 8 to 36 MHz. An NE602 IC is used for the mixer. Sensitivity is about 3 μ V. If desired, a crystal tuning circuit for fine tuning can be obtained using a varactor.

83

Siren, Warbler, and Wailer Circuits

The sources of the following circuits are contained in the Sources section, which begins on page 707. The figure number in the box of each circuit correlates to the entry in the Sources section.

Fire Siren
Warble Oscillator
Electronic Siren
Wailing Sound Generator
Two-Tone Siren

FIRE SIREN

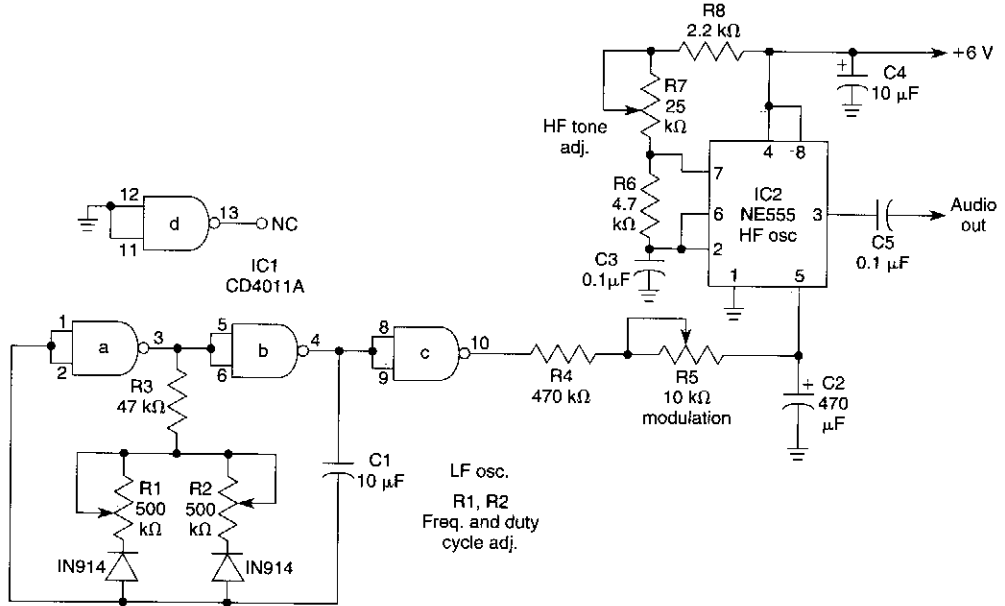

WILLIAM SHEETS

Fig. 83-1

IC1 is an LF oscillator that is variable in attack and decay time with R1 and R2. The LF output modulates HF oscillator IC2. R5 varies the modulation depth. By proper control adjustment, sirens of various types can be simulated.

WARBLE OSCILLATOR

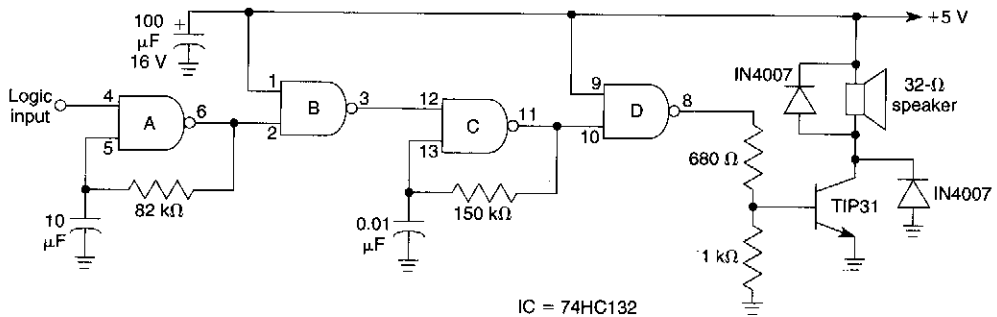

WILLIAM SHEETS

Fig. 83-2

Sections A & B form an oscillator running at 2 Hz, which gates sections C and D, a 1-kHz oscillator. This drives the TIP31 speaker driver.

ELECTRONIC SIREN

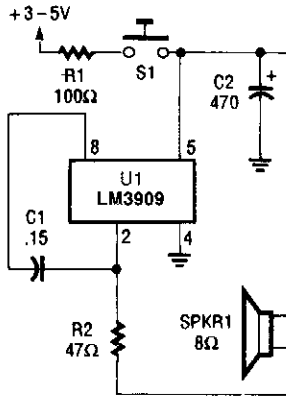

POPULAR ELECTRONICS

Fig. 83-3

In this circuit, the LM3909 is used in a simple electronic siren. When S1 is closed, C2 begins to charge rapidly through R1. When the charge on C2 reaches about 1 V, the oscillator starts. As the voltage across C1 increases toward +V, the oscillator's output frequency also increases. Releasing (opening) S1 removes power from the circuit. The oscillator continues to operate, with a decline in output volume and frequency until C1 discharges to about the 1-V level.

Experiment with the siren circuit by selecting different R_1/C_2 combinations to obtain a desired rise and fall output. Change the value of C_1 to vary the oscillator's frequency. Keep the value of R_2 at or above 47 Ω to protect the IC from drawing too much current.

WAILING SOUND GENERATOR

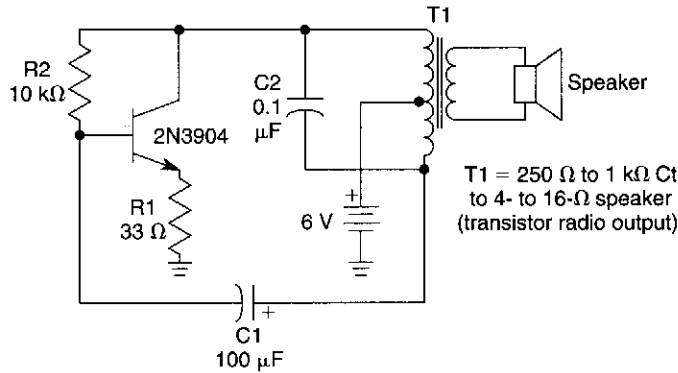

WILLIAM SHEETS

Fig. 83-4

In this circuit, C2 and T1 determine the tone generated and C_1/R_2 control the blocking rate. The signal produced is an interrupted tone, like a police whistle or toy ray gun, depending on C1 and C2.

TWO-TONE SIREN

- | | |
|----------|--|
| IC1, IC2 | LM3909 LED flasher/oscillator |
| SPKR | small 8 Ω speaker |
| C1 | 0.1 μ F capacitor |
| C2 | 470 μ F 6 V electrolytic capacitor |
| R1 | 10 k Ω 1/4 W 5% resistor |
| R2 | 4.7 k Ω 1/4 W 5% resistor |
| R3 | 100 Ω potentiometer |
| R4 | 33 Ω 1/4 W 5% resistor |

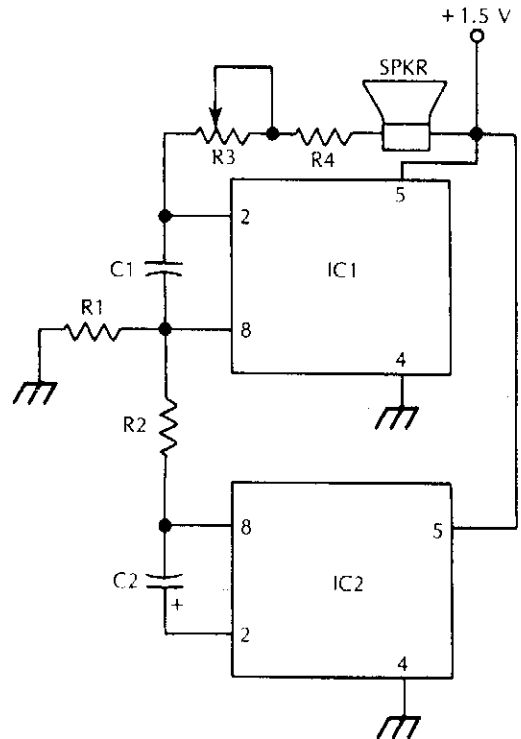

McGRAW-HILL

Fig. 83-5

IC1 generates the main siren tone while IC2 generates a low-frequency square wave, switching IC1 between two different tones.

84

Sound-Effects Circuits

The sources of the following circuits are contained in the Sources section, which begins on page 707. The figure number in the box of each circuit correlates to the entry in the Sources section.

Complex Sound-Effect Generator
Dual-Tone Generator
Surf Man Sound Generator
Electronic Whistle
Bird-Chirp Sound-Effect Generator
Robotic Chatter Sound Generator
Electronic Wind Chime
Gunshot Sound-Effects Generator

COMPLEX SOUND-EFFECT GENERATOR

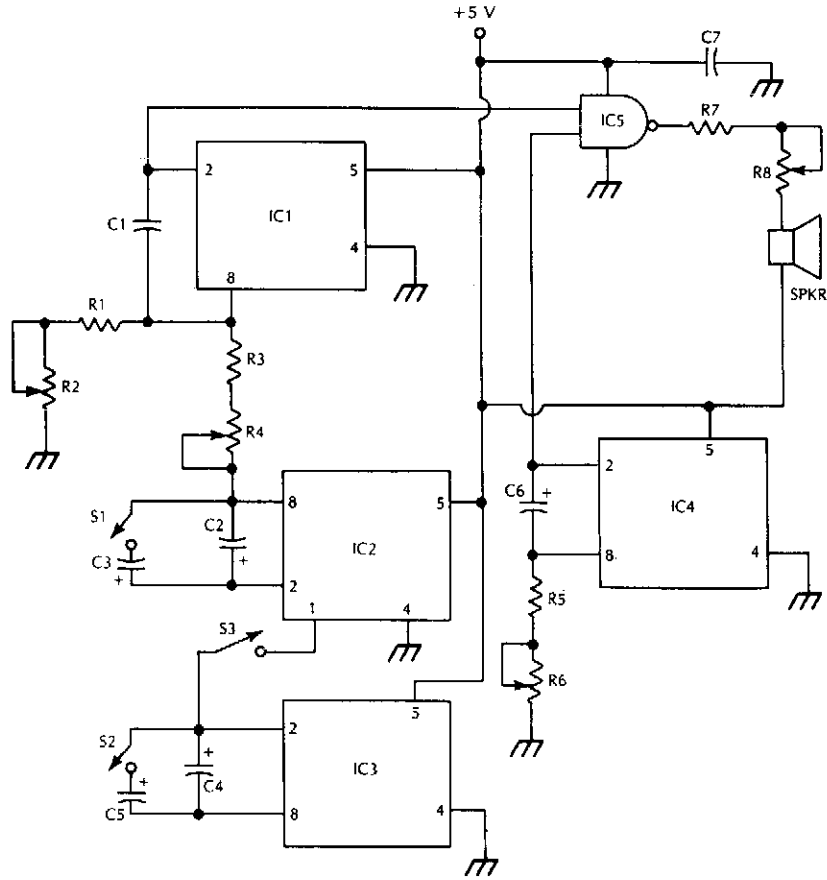

IC1-IC4	LM3909 LED flasher/oscillator	C4	47 μF 6 V electrolytic capacitor
IC5	7400 quad NAND gate	C5	33 μF 6 V electrolytic capacitor
SPKR	small loudspeaker	C6	4.7 μF 6 V electrolytic capacitor
S1, S2, S3	SPST switch	R1, R3, R5	2.2 k Ω 1/4-W 5% resistor
C1	0.1 μF capacitor	R2, R4, R6	10 k Ω potentiometer
C2	22 μF 6 V electrolytic capacitor	R7	33 Ω 1/4 W 5% resistor
C3	10 μF 6 V electrolytic capacitor	R8	100 Ω potentiometer

McGRAW-HILL

Fig. 84-1

This system uses four free running oscillators to produce a wide variety of complex sounds. LF oscillator IC3 modulates IC2, which modulates IC1. The audio from IC1 is combined with a variable frequency from IC4. Switches at various points allow oscillators IC3 to be switched in or out, IC1 and IC2 to be varied in frequency, and IC4 also can be varied in frequency. The circuit is not critical and different arrangements can be tried to produce various sound effects.

DUAL-TONE GENERATOR

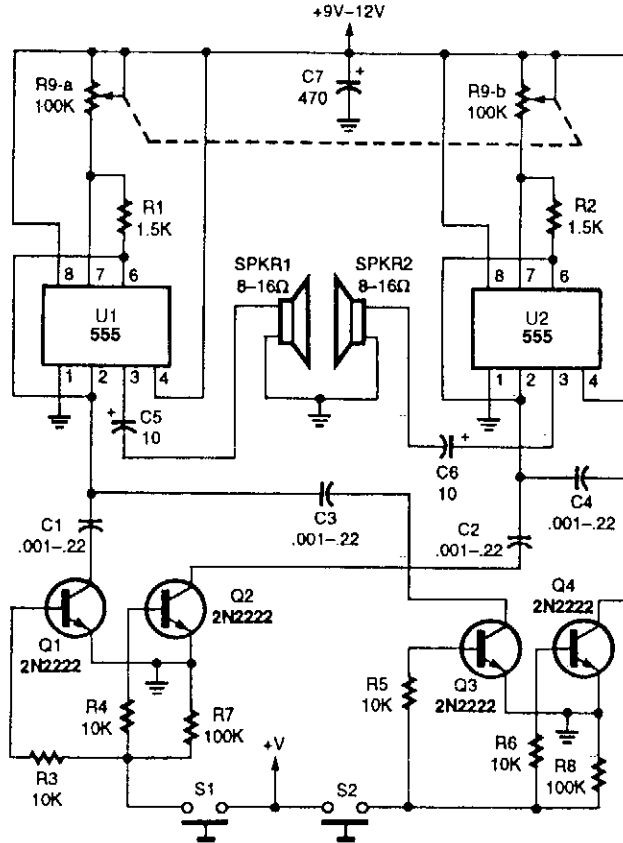

POPULAR ELECTRONICS

Fig. 84-2

Two 555 oscillator/timers are configured similarly as audio oscillators, with each oscillator feeding a separate speaker.

A dual 100-k Ω potentiometer is used to tune the two oscillators simultaneously. The oscillators' frequency range is controlled by a dual-transistor switch, which selects the timing capacitor for both oscillators. Although the circuit only shows two range-switching circuits, any number can be added by simply duplicating the two-transistor switching circuit.

SURF MAN SOUND GENERATOR

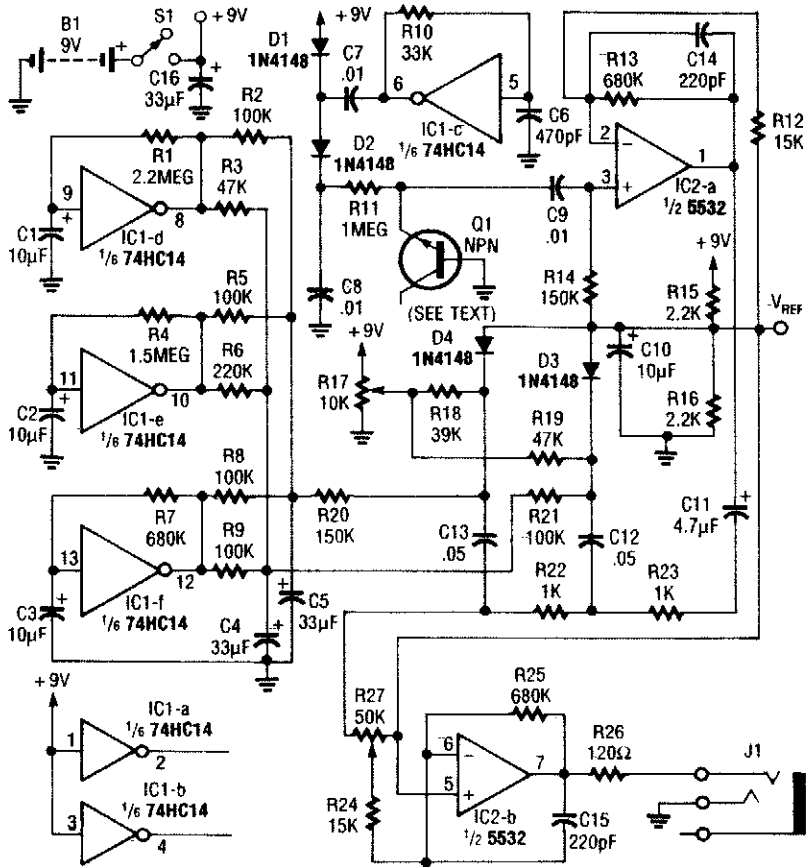
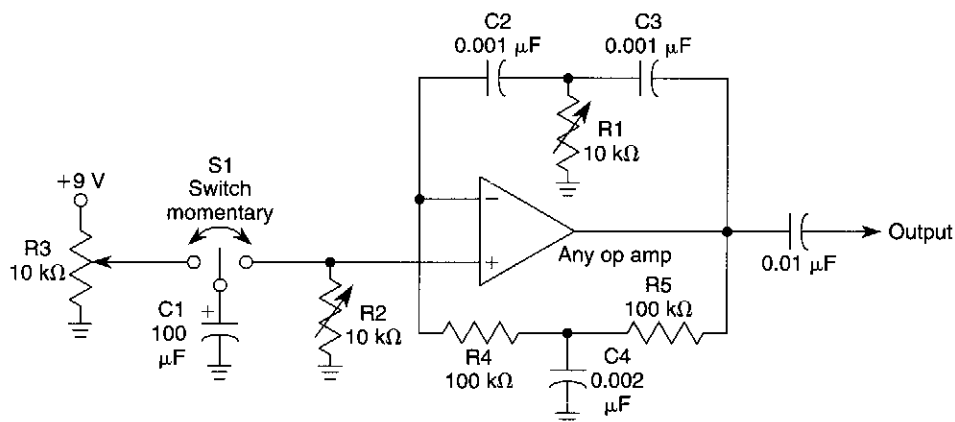

Fig. 84-3

Three low-frequency oscillators (IC1d, e, f) are used to simulate "wave action" of the surf. Q1 is an emitter-base junction used as a diode noise generator, biased by dc derived from oscillator IC1-c. The noise is fed into two voltage-controlled filters R22, R23, C12, C13, with D3 and D4 as "tuning" elements. The low-frequency oscillator signals randomly vary the filters, therefore, the spectrum of the noise signal fed through them. This simulates the sound of a surf.

ELECTRONIC WHISTLE



WILLIAM SHEETS

Fig. 84-4

The circuit shown is a twin-tec oscillator. R1 varies the pitch, R2 the duration, and R3 the format (bell, rise & fall time, etc.). Vary R4, R5, C4 and C2, C3 for large shifts in frequency.

BIRD-CHIRP SOUND-EFFECT GENERATOR

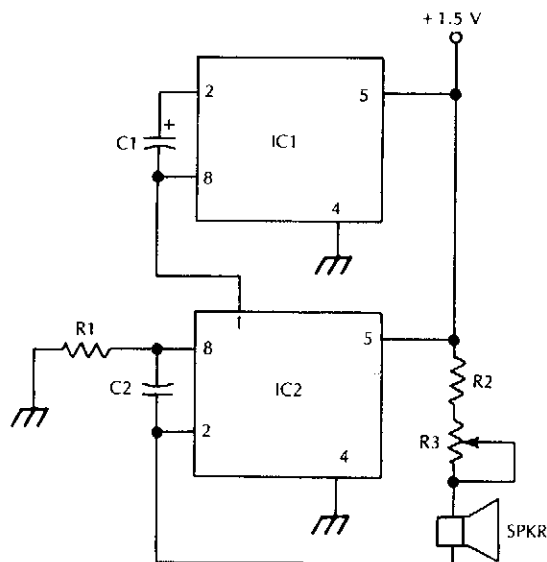

- IC1, IC2 LM3909 LED flasher/oscillator IC
- C1 33 μ F 5 V electrolytic capacitor
- C2 0.1 μ F capacitor
- R1 15 k Ω 1/4 W 5% resistor
- R2 33 Ω 1/4 W 5% resistor
- R3 250 Ω potentiometer
- SPKR small 8 Ω speaker

McGRAW-HILL

Fig. 84-5

A low-frequency oscillator modulates a higher frequency oscillator, which drives the speaker.

ROBOTIC CHATTER SOUND GENERATOR

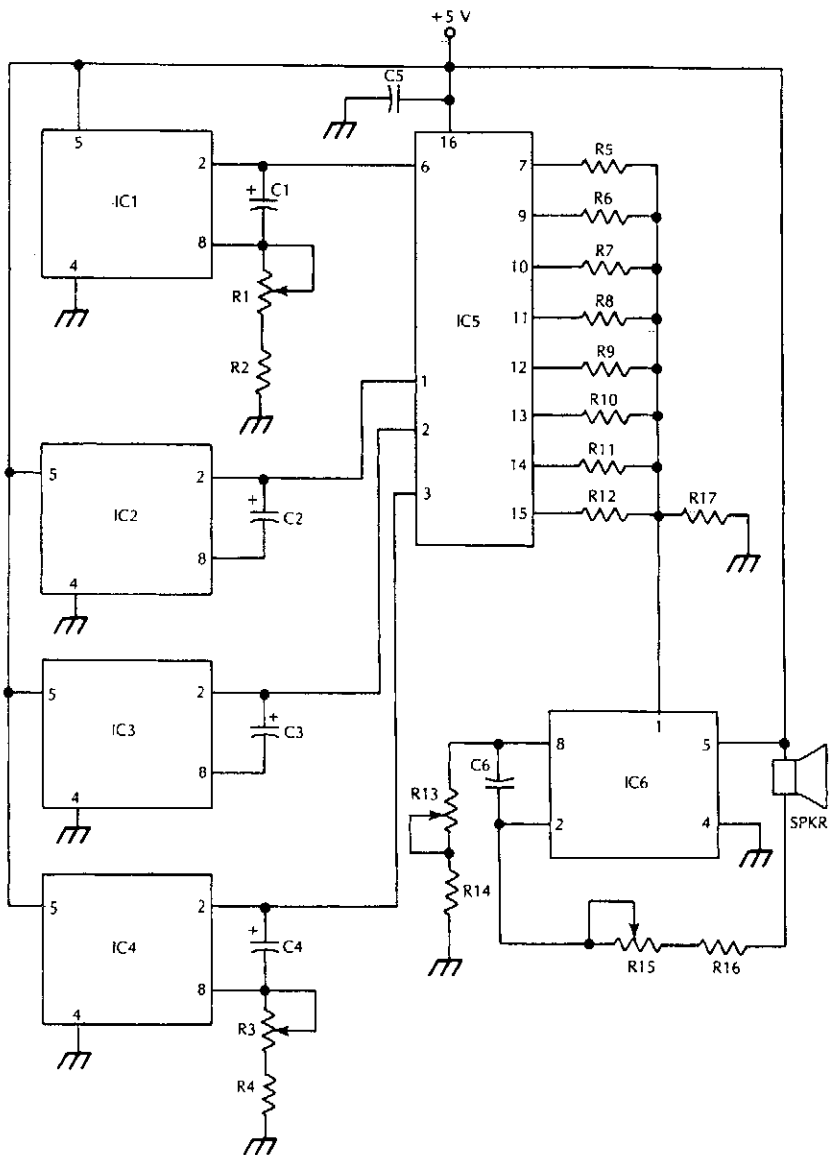

McGRAW-HILL

Fig. 84-6

This circuit simulates sound effects of a robot, for toy or novelty applications.

ROBOTIC CHATTER SOUND GENERATOR (Cont.)

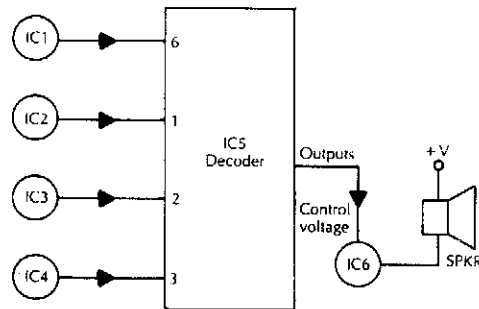

IC1–IC4, IC6	LM3909 LED flasher/oscillator	R5	6.8 k Ω ¼ W 5% resistor
IC5	74LS138 three-line to eight-line decoder	R6	10 k Ω potentiometer
SPKR	small loudspeaker	R7	2.2 k Ω ¼ W 5% resistor
C1	10 μ F 10 V electrolytic capacitor	R8	33 k Ω ¼ W 5% resistor
C2	22 μ F 10 V electrolytic capacitor	R9	3.9 k Ω ¼ W 5% resistor
C3	33 μ F 10 V electrolytic capacitor	R10	4.7 k Ω ¼ W 5% resistor
C4	100 μ F 10 V electrolytic capacitor	R11	100 k Ω ¼ W 5% resistor
C5	0.01 μ F capacitor	R12	470 k Ω ¼ W 5% resistor
C6	0.1 μ F capacitor	R15	100 Ω potentiometer
R1, R3, R14	10 k Ω potentiometer	R16	33 Ω ¼ W 5% resistor
R2, R4, R13	3.3 k Ω ¼ W-5% resistor	R17	1 M Ω ¼ W fixed resistor

ELECTRONIC WIND CHIME

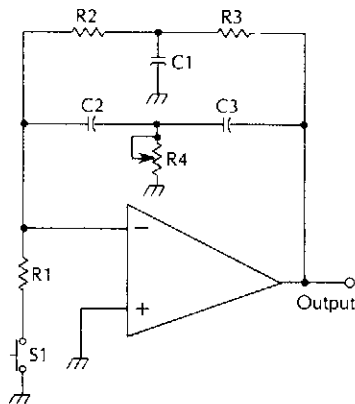

The value of R_4 controls the damping or decay time of the feedback circuit (a twin Tee oscillator). When S1 is closed, the circuit breaks into oscillation. When S1 is opened, the circuit stops oscillating generating a decaying tone like a bell. The frequency is approximately $\frac{1}{RC}$. C1, C2, and C3 are typically in the 0.01- μ F range.

GUNSHOT SOUND-EFFECTS GENERATOR

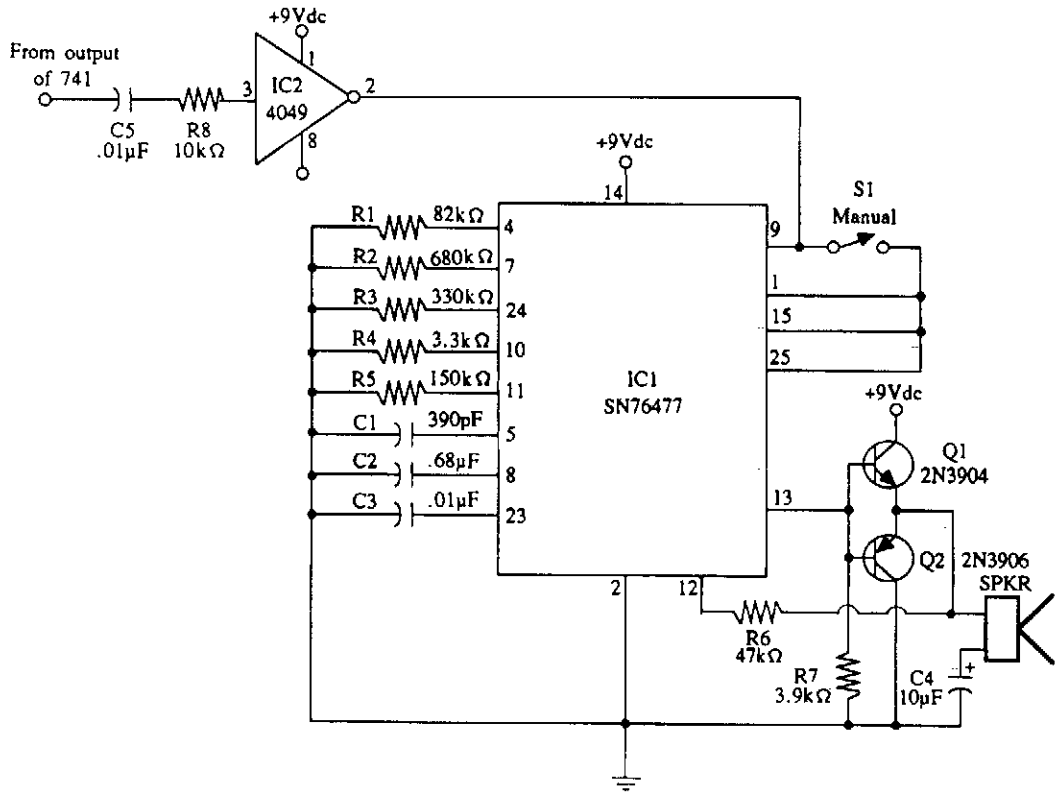

McGRAW-HILL

Fig. 84-8

Gunshot sound-effects generator built around a Texas Instruments SN76477 sound chip. An input pulse causes IC1 to generate a gunshot sound.

85

Square-Wave Generator Circuits

The sources of the following circuits are contained in the Sources section, which begins on page 707. The figure number in the box of each circuit correlates to the entry in the Sources section.

Square-Wave Generator

Sharp Square Waveforms from Multivibrator

SQUARE-WAVE GENERATOR

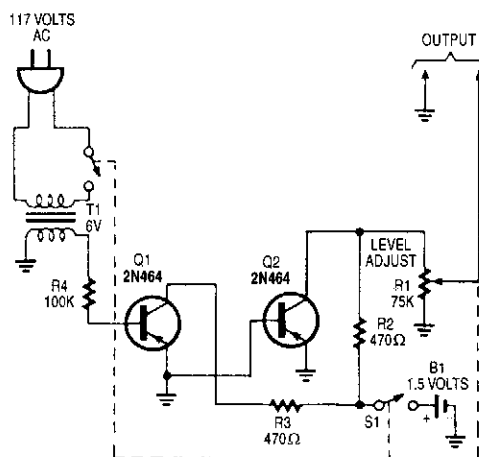

POPULAR ELECTRONICS

Fig. 85-1

A 60-Hz waveform from T1 drives an audio amplifier to clipping. Output is 60 Hz with about 0- to 1.4-V p-p amplitude.

SHARP SQUARE WAVEFORMS FROM MULTIVIBRATOR

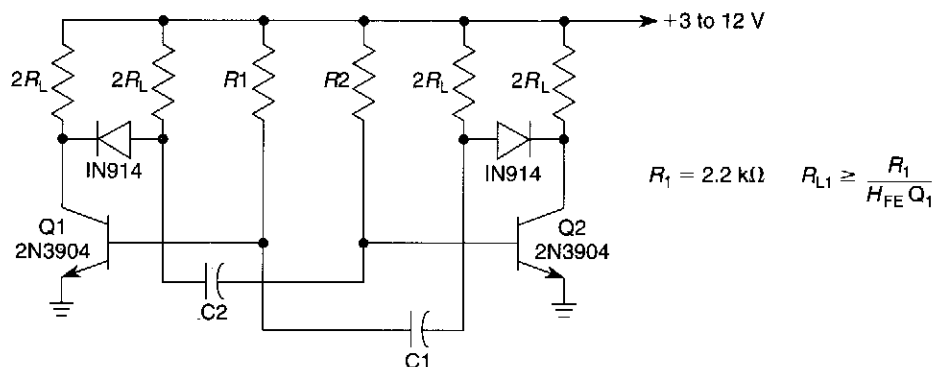

WILLIAM SHEETS

Fig. 85-2

By using diodes as shown, the loading effect on the collector of the transistors caused by the timing capacitors can be avoided. As the collector of the transistors rises toward V_{CC} , the diode disconnects the timing capacitors.

86

Staircase Generator Circuits

The sources of the following circuits are contained in the Sources section, which begins on page 707. The figure number in the box of each circuit correlates to the entry in the Sources section.

Stepped Triangle Waveform Generator
Video Staircase Generator
Free-Running Staircase Wave Generator
Up/Down Staircase Wave Generator

STEPPED TRIANGLE WAVEFORM GENERATOR

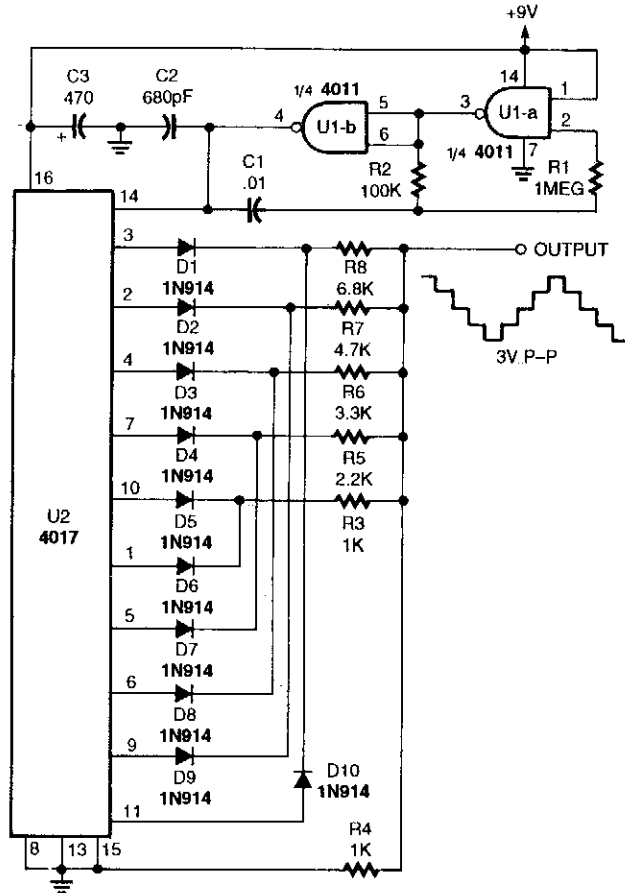

POPULAR ELECTRONICS

Fig. 86-1

Two gates of a 4011 quad two-input NAND gate (U1) are connected in a pulse generator circuit. The square output at pin 4 of U1-b, connects to the clock input, pin 14, of a 4017 decade counter IC (U2). For each input clock pulse, the 4017 takes a single step. Because the 4017 counter is set up to count ten and then repeat the count, the stepped output frequency will only be $\frac{1}{10}$ of the clock frequency. For a 100-Hz output, the clock generator must operate at 1 kHz.

The 4017's positive output pulses begin at pin 3 and progress to pin 11 in a serial manner. The first output pulse, at pin 3, passes through D1 and R8 and appears across R4 to produce the first step up the triangle. The second pulse is routed through D2 and R7 to produce the second step. The outputs at pins 10 and 1 form the top of the waveform and outputs at pins 5, 6, 9, and 11 produce the down steps.

VIDEO STAIRCASE GENERATOR

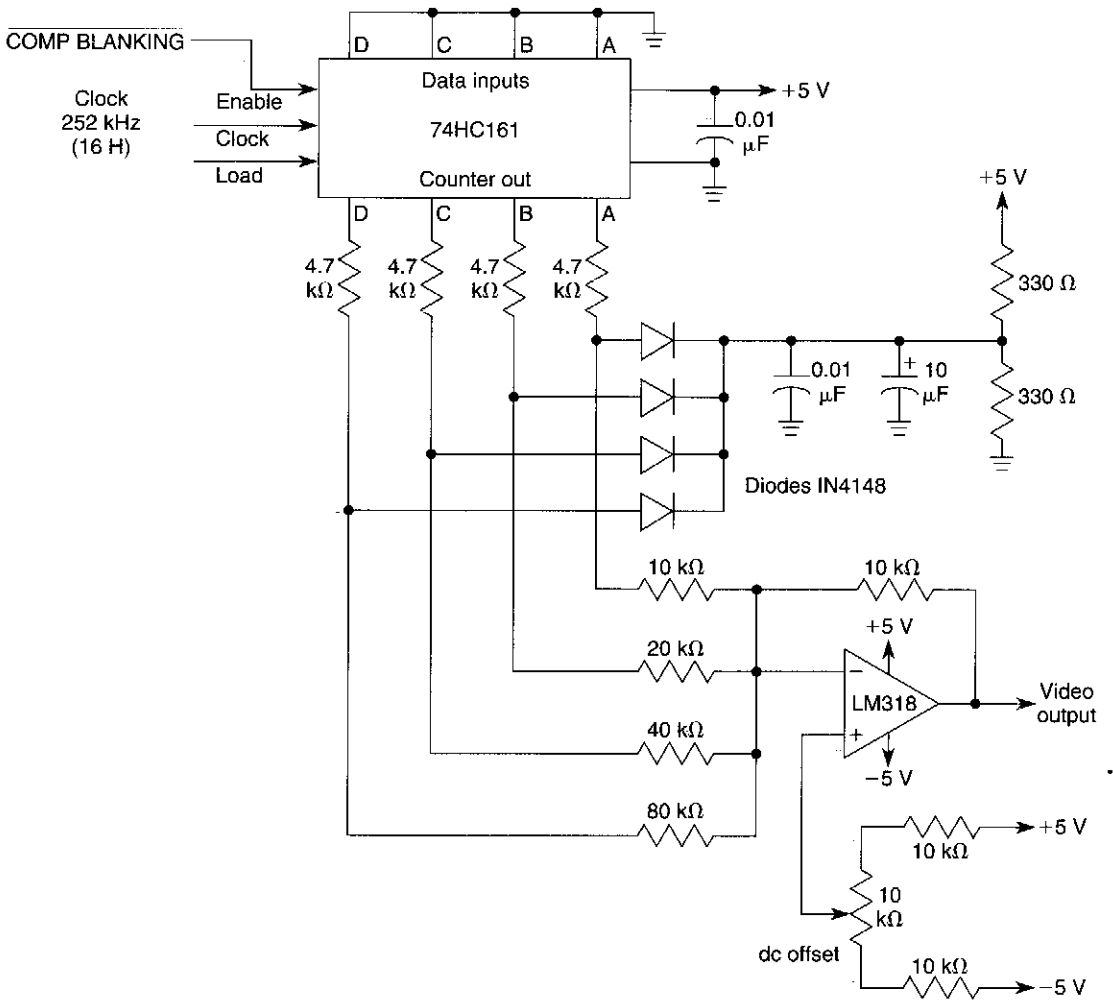

WILLIAM SHEETS

Fig. 86-2

Using a 74HC161 counter and a simple D-A converter using an op amp and resistor network, a very simple video staircase generator for gray-scale generation (12 bars) can be obtained. The output is clean and mostly free of "glitches."

FREE-RUNNING STAIRCASE WAVE GENERATOR

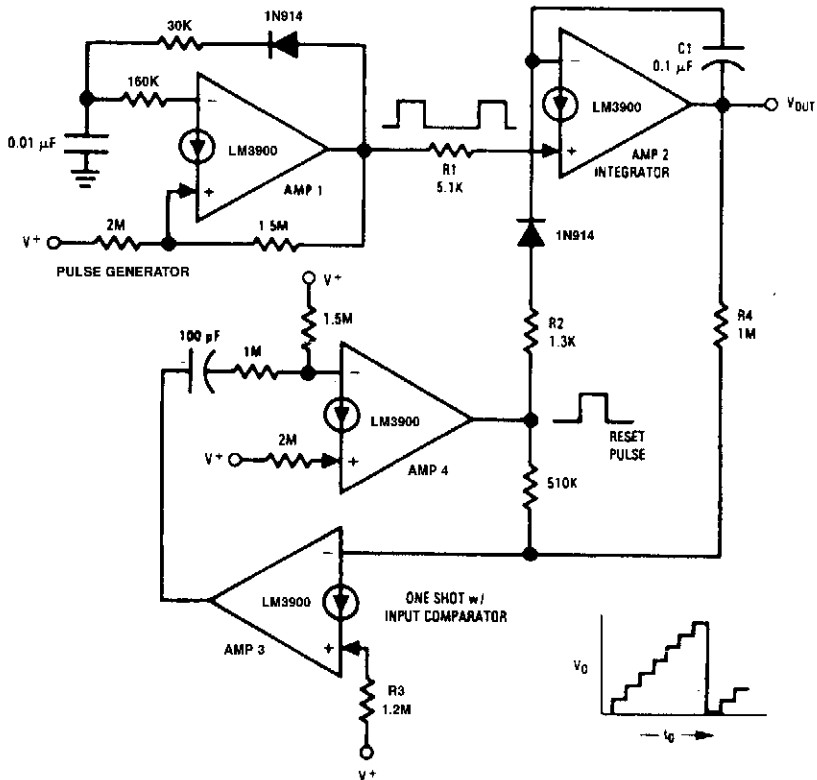

NATIONAL SEMICONDUCTOR

Fig. 86-3

This free-running staircase generator uses all four of the amplifiers, which are available in one LM3900 package. Amp 1 provides the input pulses that “pump up” the staircase via resistor $R1$. Amp 2 does the integrate and hold function and also supplies the output staircase waveform. Amps 3 and 4 provide both a compare and a one-shot multivibrator function. Resistor $R4$ is used to sample the staircase output voltage and to compare it with the power supply voltage ($V+$) via $R3$. When the output exceeds approximately 80% of $V+$ the connection of Amps 3 and 4 causes a $100\text{-}\mu s$ reset pulse to be generated. This is coupled to the integrator (AMP2) via $R2$ and causes the staircase output voltage to fall to approximately 0 V. The next pulse out of Amp 1 then starts a new stepping cycle.

UP/DOWN STAIRCASE WAVE GENERATOR

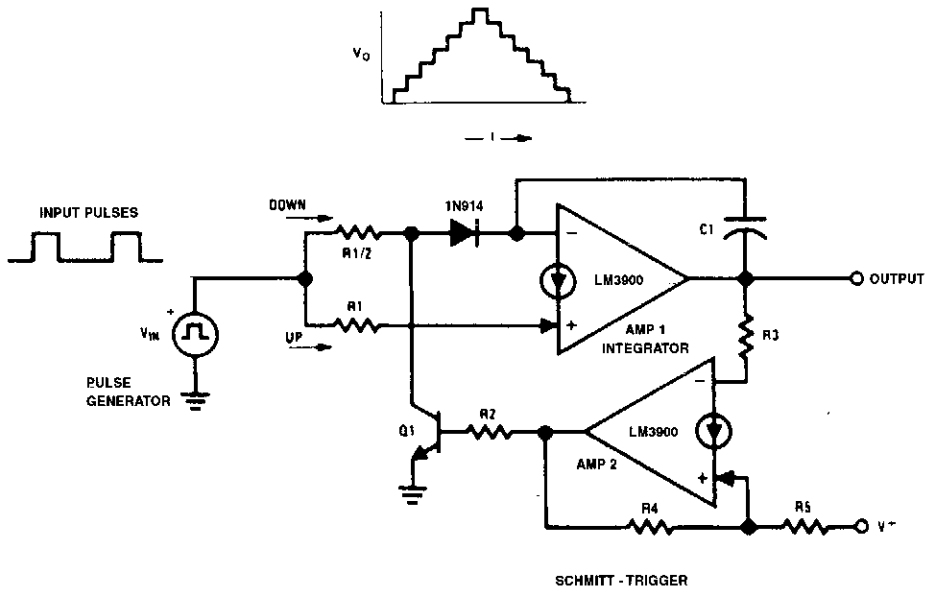

NATIONAL SEMICONDUCTOR

Fig. 86-4

This staircase waveform first steps up and then steps down by the circuit shown. An input pulse generator provides the pulses that cause the output to step up or down, depending on the conduction of the clamp transistor, Q1. When this is ON, the "down" current pulse is diverted to ground and the staircase then steps "up." When the upper voltage trip point of Amp 2 is reached, Q1 goes OFF and as a result of the smaller "down" input resistor (one-half the value of the "up" resistor, R1), the staircase steps "down" to the low-voltage trip point of Amp 2. The output voltage, therefore, steps up and down between the trip voltages of the Schmitt Trigger.

87

Stepper Motor Circuits

The sources of the following circuits are contained in the Sources section, which begins on page 707. The figure number in the box of each circuit correlates to the entry in the Sources section.

Stepper Motor Pulse Generator
Stepper Motor as Shaft Encoder
Stepper Motor Encoder Circuit

STEPPER MOTOR PULSE GENERATOR

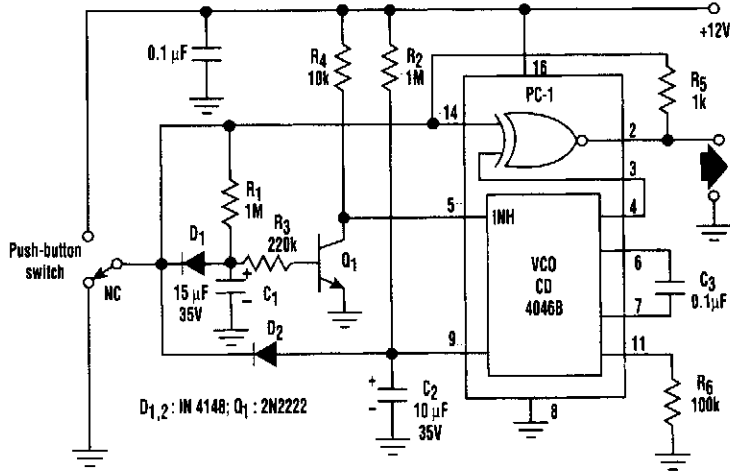

Fig. 87-1

ELECTRONIC DESIGN

When the switch is in its normally closed (NC) position, capacitors C1 and C2 are held discharged by diodes D1 and D2. Switching off transistor Q1 inhibits the voltage-controlled oscillator of the PLL. The two inputs and, hence, the output of the EX-OR gate (phase comparator 1) of the PLL remain at the logic 0 level.

When the pushbutton is pressed, C1 and C2 are allowed to charge via resistors R1 and R2. The VCO is enabled only after a time delay (≈ 0.5 second) set by R1, R3, and C1. During this delay period, the EX-OR gate output follows the logic level at the switch output. As a result, one-shot pulses can be generated by pressing the pushbutton, then releasing it within 0.5 second. R5 provides the switch-debouncing function.

If the pushbutton is pressed for more than 0.5 second, the VCO is enabled. The rising voltage at the control input (pin 9) causes a linear increase in VCO frequency and thus accelerates the stepper motor. Releasing the pushbutton discharges C1 and C2 and inhibits the VCO.

STEPPER MOTOR AS SHAFT ENCODER

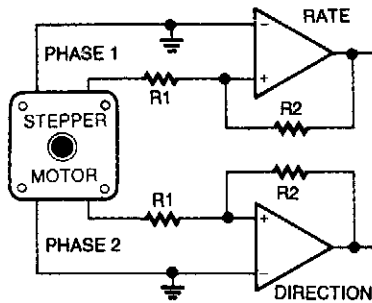

To use a stepper as a shaft encoder, the output signals must be converted to square waves with a pair of voltage comparators.

STEPPER MOTOR ENCODER CIRCUIT

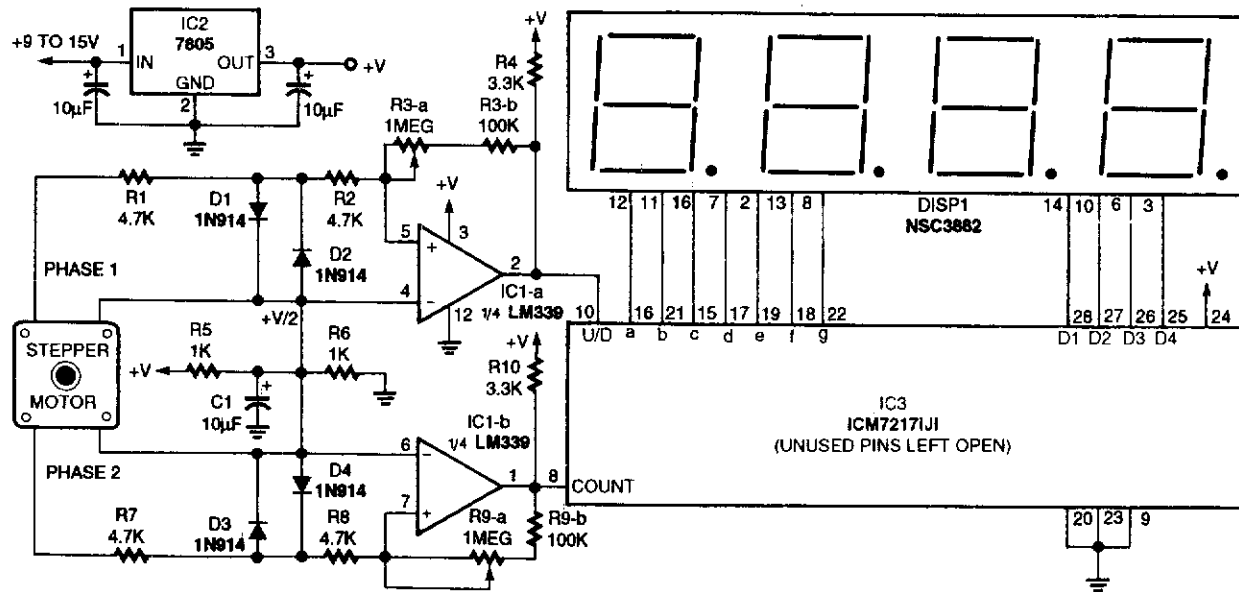

ELECTRONICS NOW

Fig. 87-3

This circuit translates shaft rotation and direction to a readout on an LED display. A stepper motor is used as an encoder.

Switching Circuits

The sources of the following circuits are contained in the Sources section, which begins on page 707. The figure number in the box of each circuit correlates to the entry in the Sources section.

Isolated Switch	Pin Diode Switch
Analog Switched Inverter	Transceiver T/R Switch
Analog Switch Circuit	Series/Shunt Pin-Diode RF Switch
Low Output Impedance Multiplexer	Auto-Off Power Switch
Op-Amp and Analog Switch RON Compensator	Switch-On Delay Circuit
Oscillator Triggered Switch	HEXFET Switch Circuits
Basic Zero-Crossing Switch Circuit	Alternating On/Off Control
Analog Switch	Audio-Controlled Switch
Shunt Pin-Diode Switch	Switch Debouncers
Receiver Bandswitching	Simple Switch Debouncer
Resistor Pin-Diode Switch	Analog Switch Circuit
Digitally Controlled One-of-Four Analog Switch	

ISOLATED SWITCH

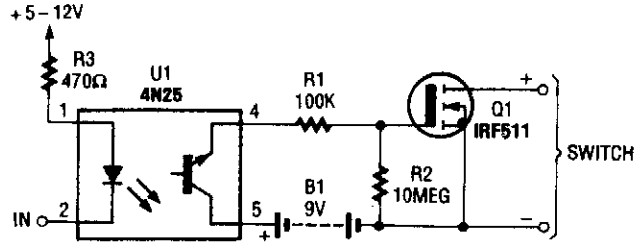

POPULAR ELECTRONICS

Fig. 88-1

This dc-controlled switch uses an optoisolator/coupler, U1, to electrically isolate the input signal from the output control device.

ANALOG SWITCHED INVERTER

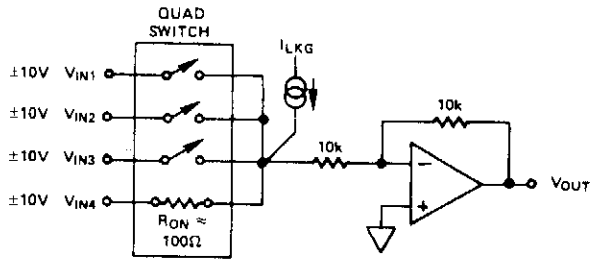

ANALOG DEVICES

Fig. 88-2

ANALOG SWITCH CIRCUIT

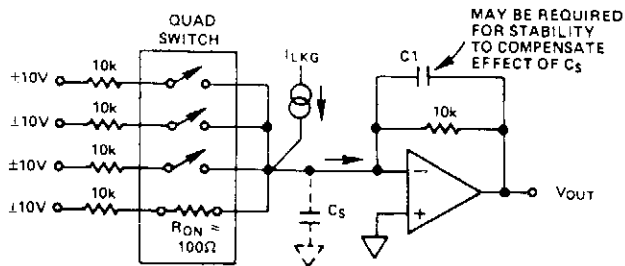

ANALOG DEVICES

Fig. 88-3

LOW OUTPUT IMPEDANCE MULTIPLEXER

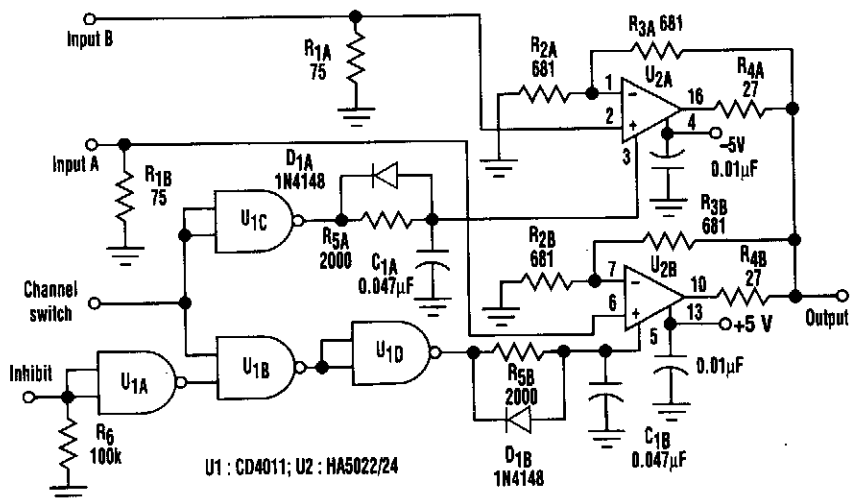

Fig. 88-4

ELECTRONIC DESIGN

Both inputs are terminated in their characteristic impedance; 75 Ω is typical for video applications. Because the output cables usually are terminated in their characteristic impedance, the gain is 0.5. Consequently, amplifiers U2A and U2B are configured in a gain of +2 to set the circuit gain at 1. R_2 and R_3 determine the amplifier gain; if a different gain is desired, R_2 should be changed according to the equation $G = (1 + R_3/R_2)$. R5, LCL1, and D1 make up an asymmetrical charge/discharge time circuit that configures U1 as a break-before-make switch to prevent both amplifiers from being active simultaneously. The multiplexer transition time is approximately 15 μs with the component values shown.

OP-AMP AND ANALOG SWITCH RON COMPENSATOR

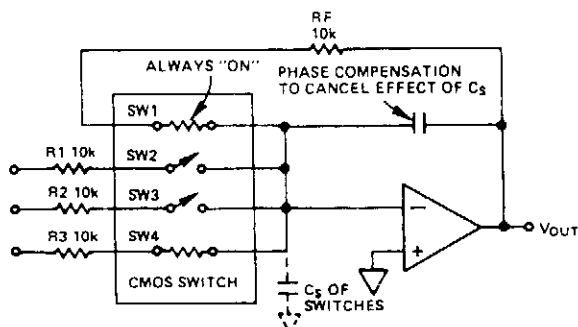
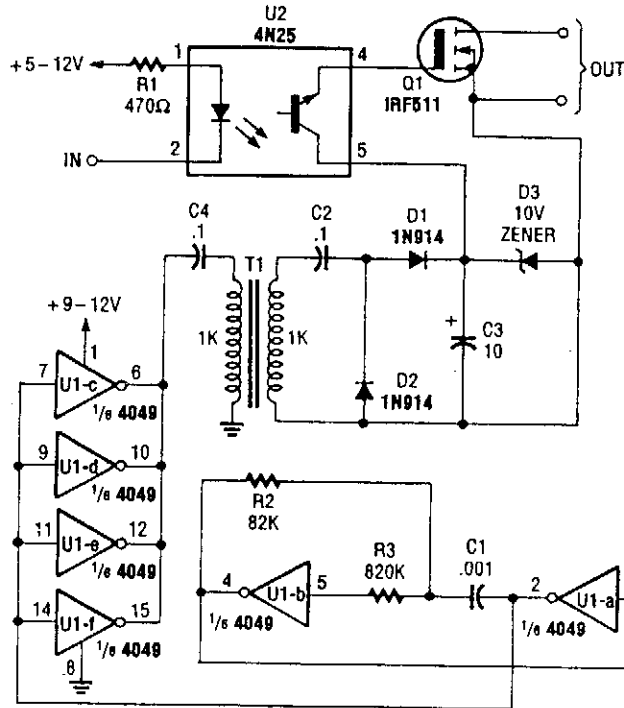

Fig. 88-5

ANALOG DEVICES

This switch is in series with feedback resistor to compensate gain.

OSCILLATOR TRIGGERED SWITCH



POPULAR ELECTRONICS

Fig. 88-6

In this circuit (the oscillator-triggered switch), the HEXFET's base bias is provided by a signal generated by an astable oscillator.

BASIC ZERO-CROSSING SWITCH CIRCUIT

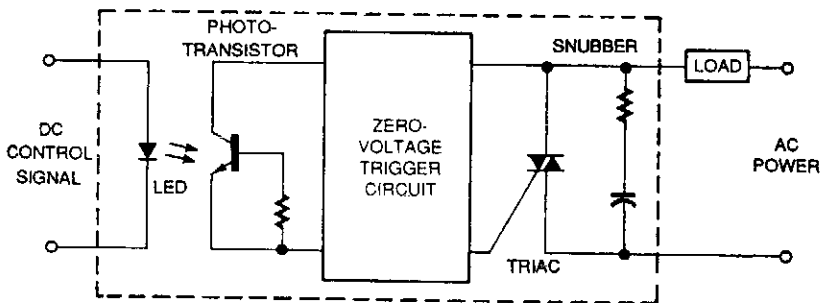

ELECTRONICS NOW

Fig. 88-7

Here is the schematic of a solid-state ac relay with zero-crossing. The triac permits the relay to switch to ac directly.

ANALOG SWITCH

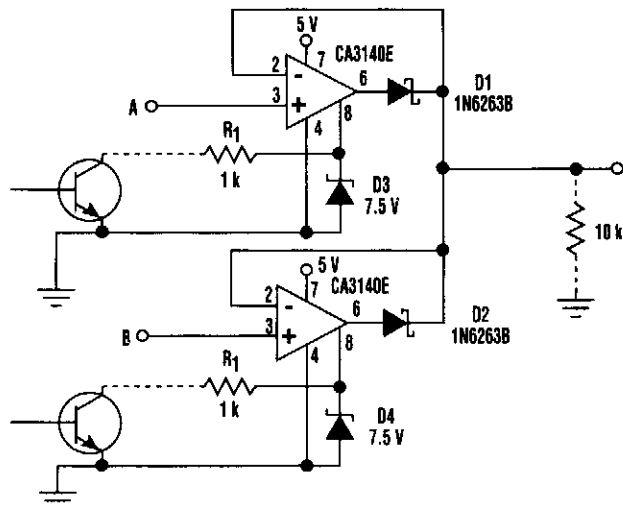

ELECTRONIC DESIGN

Fig. 88-8

This design takes advantage of the strobed output stage of a CA3140 amplifier. With the strobing capability, the circuit's output voltage can be set to either of the input voltages by grounding one of the control inputs, either A or B.

When the strobe input at pin 8 is taken below 1 V, that amplifier is disabled. The remaining amplifier then acts as a unity-gain high-impedance buffer.

The 10-k Ω output resistor enables the output voltage to swing down to 20 mV from ground. The Zener-diode clamps and associated resistors connected at the strobe inputs can be omitted for the lowest-cost applications. However, experience has shown that they allow the amplifiers to shrug off the effect of high transient voltages.

The circuit is particularly suited to 8-bit microcontroller applications, where the strobe inputs can be driven directly from two open-collector output ports under software control.

The use of Schottky diodes for D1 and D2 makes possible an output swing of 2.5 V when the circuit is powered from a 5-V supply.

SHUNT PIN-DIODE SWITCH

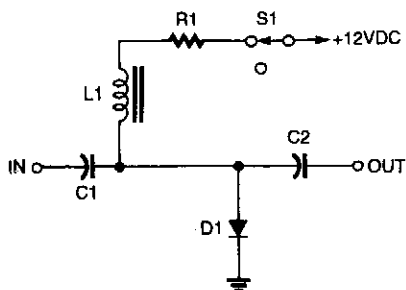

This PIN-diode switching circuit directs signals to ground when D1 is forward-biased. R1 is typically 470 Ω to 2.2 k Ω . $C_1 = C_2 = 0.1 \mu\text{F}$.

Fig. 88-9

RECEIVER BANDSWITCHING

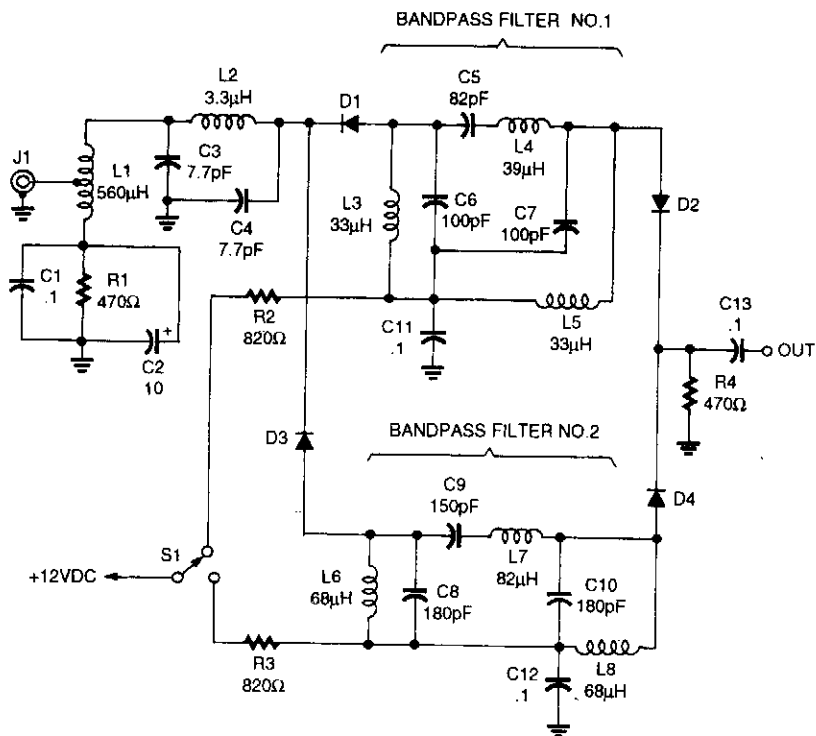

POPULAR ELECTRONICS

Fig. 88-10

Eight-band receiver front-end selection can be accomplished by using PIN diode switches.

RESISTOR PIN-DIODE SWITCH

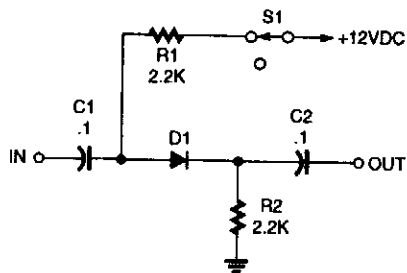

POPULAR ELECTRONICS

Fig. 88-11

This circuit uses resistors instead of RF chokes to keep costs low. The values of R_1 and R_2 should be no lower than about 1 k Ω to minimize loss.

DIGITALLY CONTROLLED ONE-OF-FOUR ANALOG SWITCH

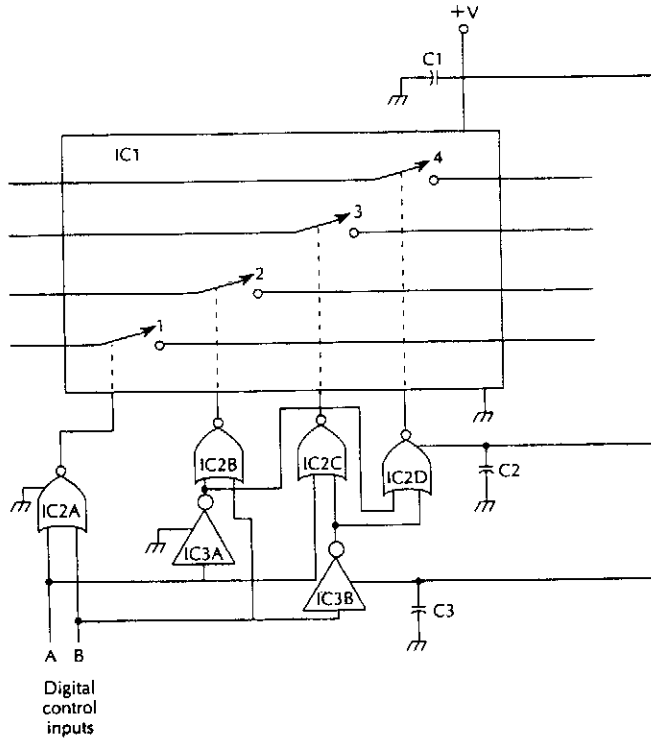

McGRAW-HILL

Fig. 88-12

IC1 = CD4066
 IC2 = CD4001
 IC3 = CD4049
 All capacitors = 0.1 μ F

PIN DIODE SWITCH

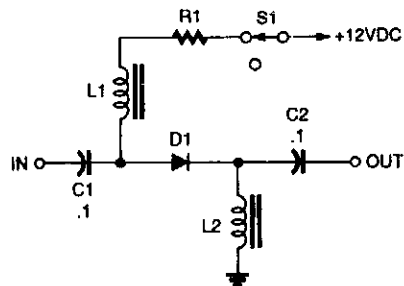

POPULAR ELECTRONICS

Fig. 88-13

This PIN diode switch uses RF chokes and a single diode. R1 is typically 470 Ω to 2.2 k Ω .

TRANSCEIVER T/R SWITCH

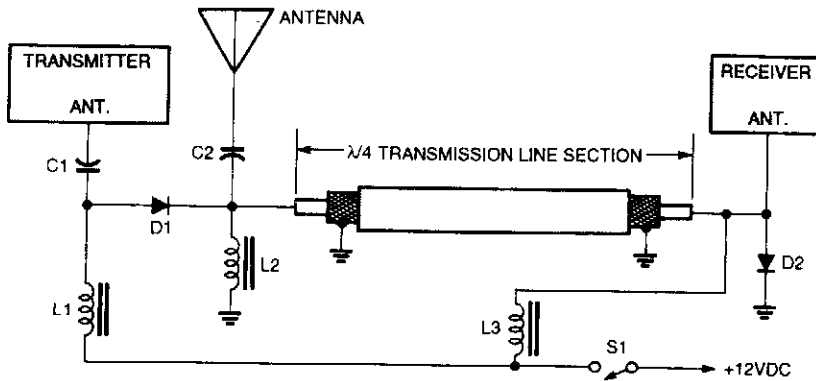

POPULAR ELECTRONICS

Fig. 88-14

This transceiver's transmit/receive switch uses PIN-diode instead of a relay. On receive, D1 is cut off, D2 is cut off and the antenna connects to the receiver. During transmit, D1 is forward-biased, as is D2. This connects the receiver input. This causes the input impedance of the transmission line to be high, so little transmitter power reaches the receiver. Although not shown in the schematic, the 12-V supply should have a series resistor of 100 Ω to 2.2 k Ω , depending on diode current, to limit diode current to a safe value.

SERIES/SHUNT PIN-DIODE RF SWITCH

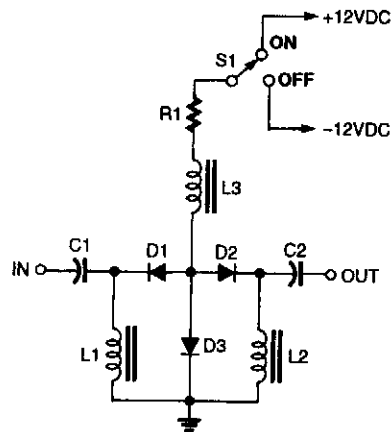

POPULAR ELECTRONICS

Fig. 88-15

A combination of series and shunt switching, like that shown here, results in superior isolation between the input and output when in the off condition.

AUTO-OFF POWER SWITCH

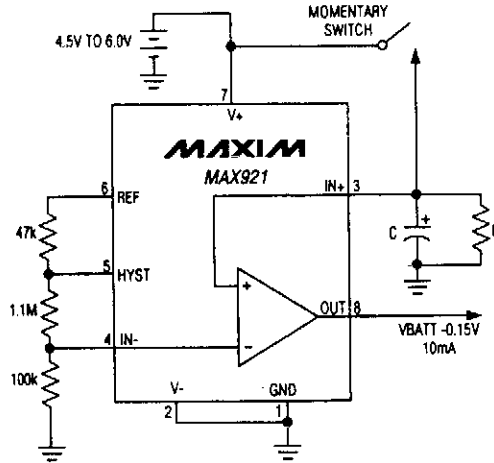
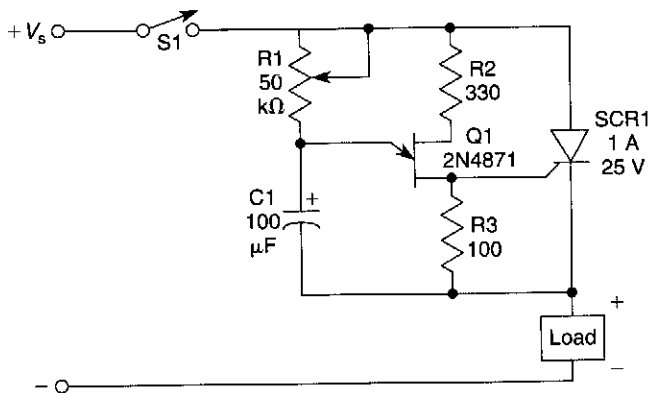

Fig. 88-16

MAXIM

This timed switch circuit can be used where a timed power source is needed. The on-time is approximately $4.6 RC$.

SWITCH-ON DELAY CIRCUIT



$$\text{Load } R < \frac{V_s}{I_{\text{holding}}}$$

up to max. SCR rating

WILLIAM SHEETS

Fig. 88-17

When S_1 is turned on, a very small current flows through the load. Almost the entire supply voltage appears across the SCR. When C_1 charges up to the firing voltage of Q_1 (approximately the standoff ratio of Q_1 times V_s , usually 0.4 to 0.6 V_s) through R_1 , Q_1 fires, turning on SCR1. This delivers full voltage to load, minus SCR drop (about 1.2 V). Notice that load current must exceed SCR holding current.

HEXFET SWITCH CIRCUITS

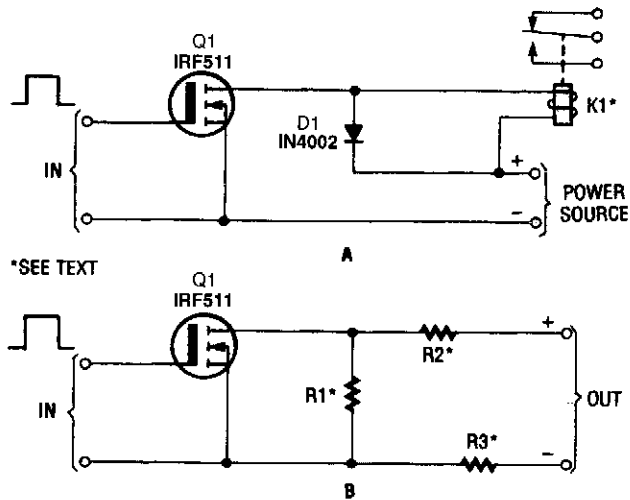

POPULAR ELECTRONICS

Fig. 88-18

The HEXFET can switch dc power to relays (as shown in A), motors, lamps, and numerous other devices. That arrangement can even be used to switch resistors in and out of a circuit, as shown in Fig. 88-18B. R1, R2, and R3 are possible load resistors and represent load configurations that can be used.

ALTERNATING ON/OFF CONTROL

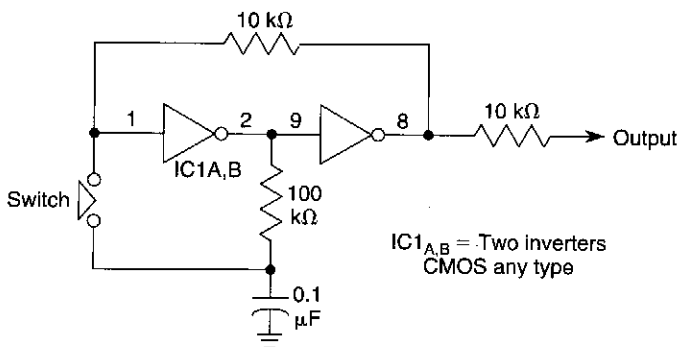

WILLIAM SHEETS

Fig. 88-19

When the switch is closed, it causes a change in the state of pins 1 through 8. This will provide a toggle flip-flop action.

AUDIO-CONTROLLED SWITCH

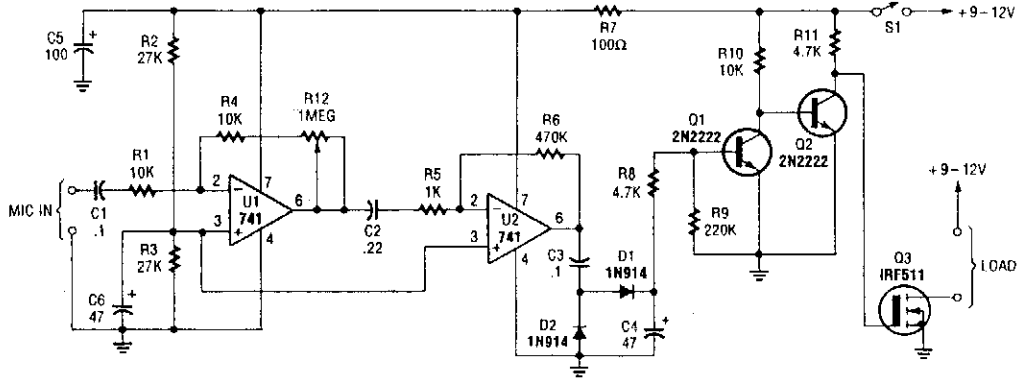

POPULAR ELECTRONICS

Fig. 88-20

The audio-controlled switch combines a pair of 741 op amps, two 2N222 general-purpose transistors, a HEXFET, and a few support components to produce a circuit that can be used to turn on a tape recorder, a transmitter, or just about anything using sound.

SWITCH DEBOUNCERS

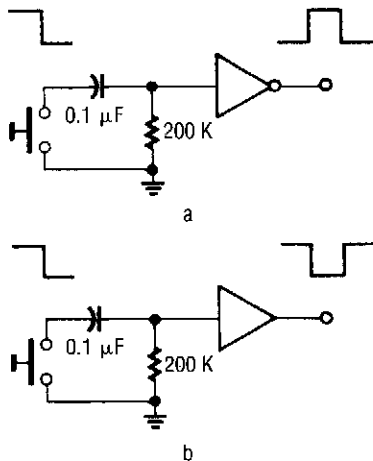

These circuits will cure problems caused by switch-contact bounce. The one shown in Fig. 88-21A provides you a positive output pulse, and the one shown in Fig. 88-21B provides you a negative output pulse.

ELECTRONICS NOW!

Fig. 88-21

SIMPLE SWITCH DEBOUNCER

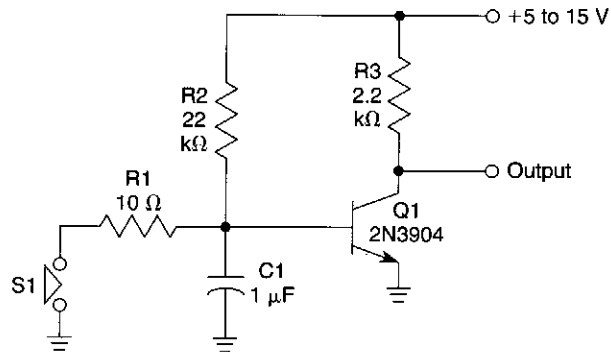

Pressing S1 discharges C1 through R1, causing Q1 to cut off, forcing the output high. Once C1 is discharged below the V_{BE} (ON) of Q1, switch bounce will have no effect on the output.

WILLIAM SHEETS

Fig. 88-22

ANALOG SWITCH CIRCUIT

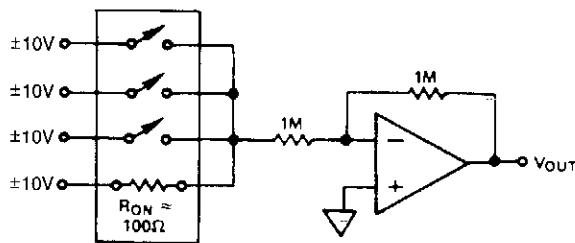

ANALOG DEVICES

Fig. 88-23

89

Sync Circuits

The sources of the following circuits are contained in the Sources section, which begins on page 707. The figure number in the box of each circuit correlates to the entry in the Sources section.

PLD Synchronizes Asynchronous Inputs
Sync Tip de Restorer
Sync Stretcher Circuit
Synchronizer Circuit

PLD SYNCHRONIZES ASYNCHRONOUS INPUTS

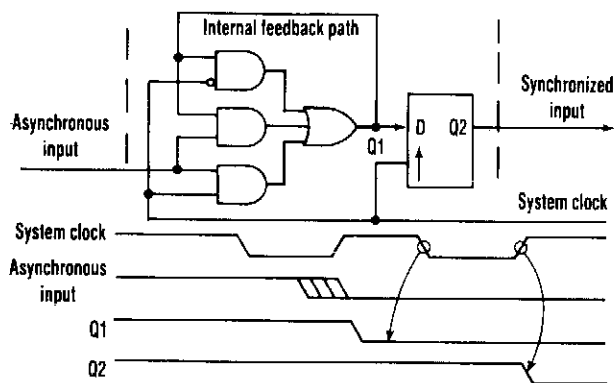

ELECTRONIC DESIGN

Fig. 89-1

A programmable electrically erasable logic (PEEL) device can easily supply the synchronizing function. Digital systems often require synchronization of asynchronous inputs to avoid the potential metastability problems caused by setup-time violations. A common synchronization method uses two rippled 74LS72 D-type flip-flops.

In this circuit, the asynchronous input feeds into the D input of the first flip-flop and its Q output feeds into the D of the second. Because the first flip-flop latches on the falling edge of the system clock, to avoid setup-time violations, the D input signal to the second flip-flop will be stabilized before the rising edge of the clock. Even experienced programmable-logic device designers often resort to such a TTL flip-flop circuit to handle the synchronization function, because of the architectural limitations of standard PLDs.

A programmable electrically erasable logic (PEEL) device, such as the PEEL18CV8 from ICT, however, can easily supply the function. The user-programmable 12-configuration I/O macrocells in the device can internally feed back a signal before the output register. With this feedback arrangement, designing a two-stage input is simple.

A gated-latch internally latches the asynchronous input on the falling edge of the system clock, generating signal Q1. ANDing the input with Q1 through the internal feedback path, eliminates a possible hazard condition during the clock's high-to-low transition time. The latch then holds Q1 stable to ensure meeting the setup-time requirement of the subsequent D flip-flop, which, as before, registers the signal on the next rising system clock edge.

If by chance the input pulse width violates the set-up time of the gated latch, the clock's low time will give more time for settling.

SYNC TIP dc RESTORER

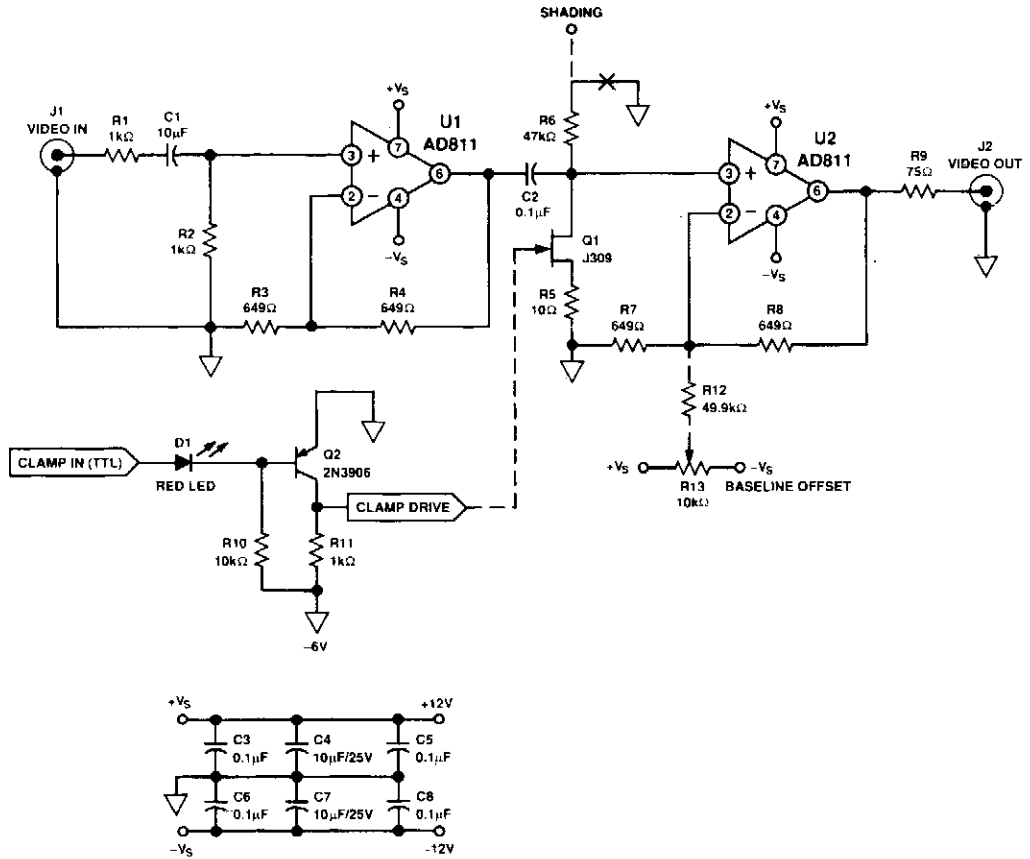

ANALOG DEVICES

Fig. 89-2

The dc restorer shown supplies a video signal with sync tips clamped to a baseline level. Clamp drive signal is supplied from elsewhere, usually a sync generator or a sync separator.

SYNC STRETCHER CIRCUIT

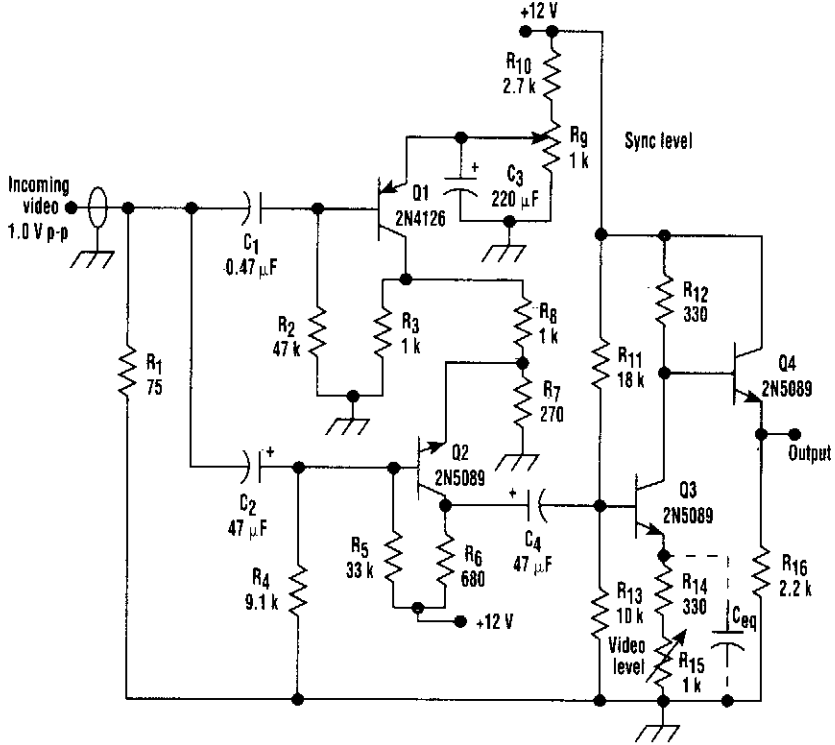

Fig. 89-3

ELECTRONIC DESIGN

Q1, Q2, and Q3 comprise a simple video amplifier and sync stretch circuit. Transistor Q1 sync strips the incoming video, which is amplified and mixed with the stripped sync in Q2. Q3 supplies inversion and video amplitude control.

SYNCHRONIZER CIRCUIT

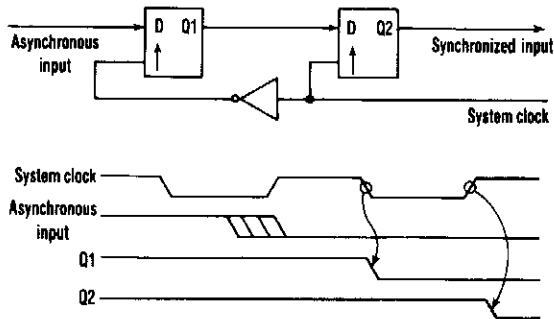

Fig. 89-4

ELECTRONIC DESIGN

This common synchronization method uses two rippled 74LS74 D-type flip-flops.

90

Telephone-Related Circuits

The sources of the following circuits are contained in the Sources section, which begins on page 707. The figure number in the box of each circuit correlates to the entry in the Sources section.

Telephone Line Tester
Caller ID Circuit
Telephone Call Restrictor
Telephone Scrambler
Universal Telephone Hold Circuit
Telephone Ring Amplifier
Bell System 202 Data Encoder
Telephone/Audio Interface
Telephone Recording Circuit
Telephone Bell Amplifier
Phone Line Simulator
Phone Helper
Telephone Ring Signal Detector
Telephone Hold Circuit

TELEPHONE LINE TESTER

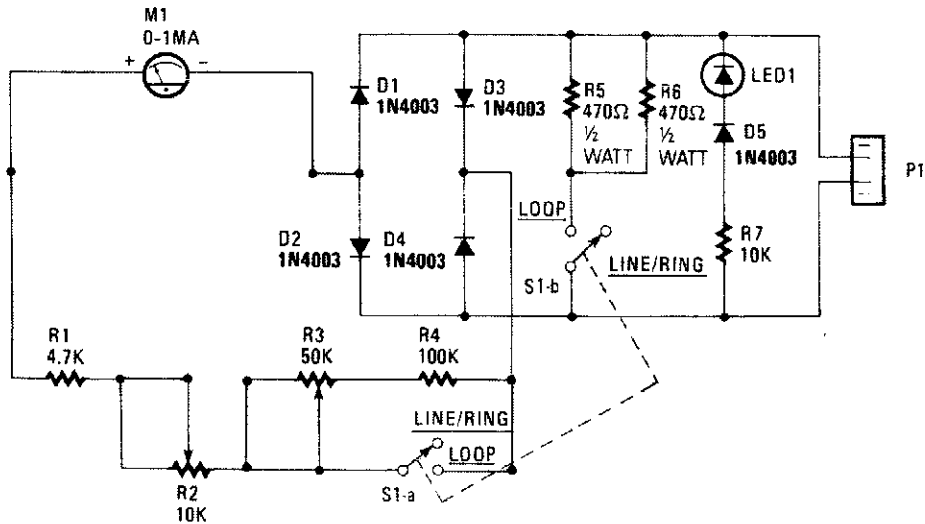

RADIO-ELECTRONICS

Fig. 90-1

The telephone-line tester shown in the figure is connected to the telephone line through modular connector P1. Because the tester's LED polarity indicator is always connected when the tester is plugged in, the instant that the unit is connected, you will have an indication of the polarity. If it is correct—that is, if the green wire is the positive side and the red wire is the negative side—nothing will happen. If the situation is reversed, the LED will light.

With switch S1 set for LINE/RING, both S1-a and S1-b are open and the meter indicates the condition of the line voltage. Any line-voltage reading in the LINE OK range (more on the meter in a moment) indicates a line voltage that is higher than 40 Vdc. If the telephone is caused to ring, either by using a ringback number or by dialing from another phone, the meter will indicate RING OK, and the LED will pulse (indicating ac), if the ringing voltage/current is correct. The actual position of the meter's pointer depends on how many ringers are connected across the line.

When S1 is closed the voltage range of the meter is changed and a nominal load resistance of 230 Ω (R5 and R6) is connected across the line to emulate the off-hook load of the telephone. If the meter indicates LOOP OK, you can be certain that you have sufficient loop voltage for satisfactory telephone operation. If you place another load on the line, perhaps by taking an extension telephone off hook, the meter reading will almost invariably drop below the LOOP OK range. If lifting the handset causes the meter reading to drop, you can at least be certain that the telephone's hook switch is working and that the repeat coil is connected to the line.

CALLER ID CIRCUIT

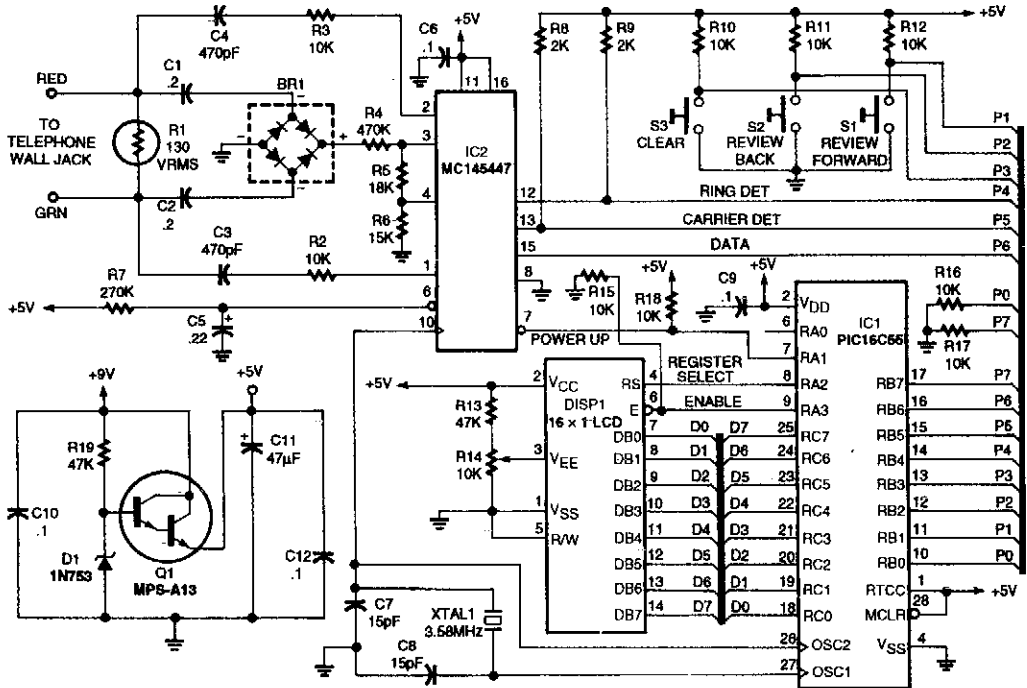

THE HEART OF THE CALLER ID circuit is microcontroller IC1 which processes the serial data from IC2, outputs ASCII characters to DISP1, and monitors switches S1-S3.

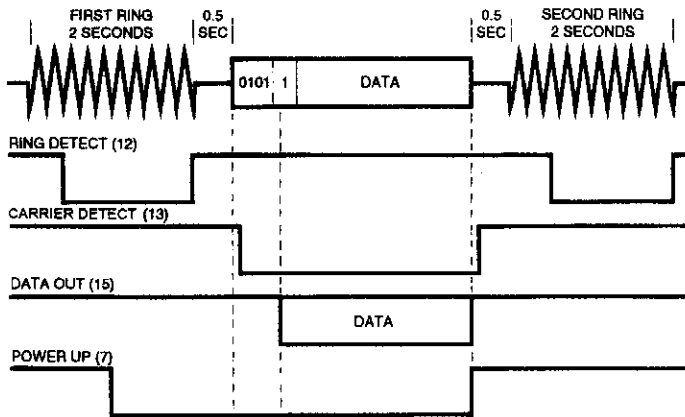

TIMING RELATIONSHIPS between the data present on the phone line (top), and the output pins of IC2.

ELECTRONICS NOW

Fig. 90-2

This circuit requires programming of the microcontroller. Software information is available from the reference in the original article.

TELEPHONE CALL RESTRICTOR

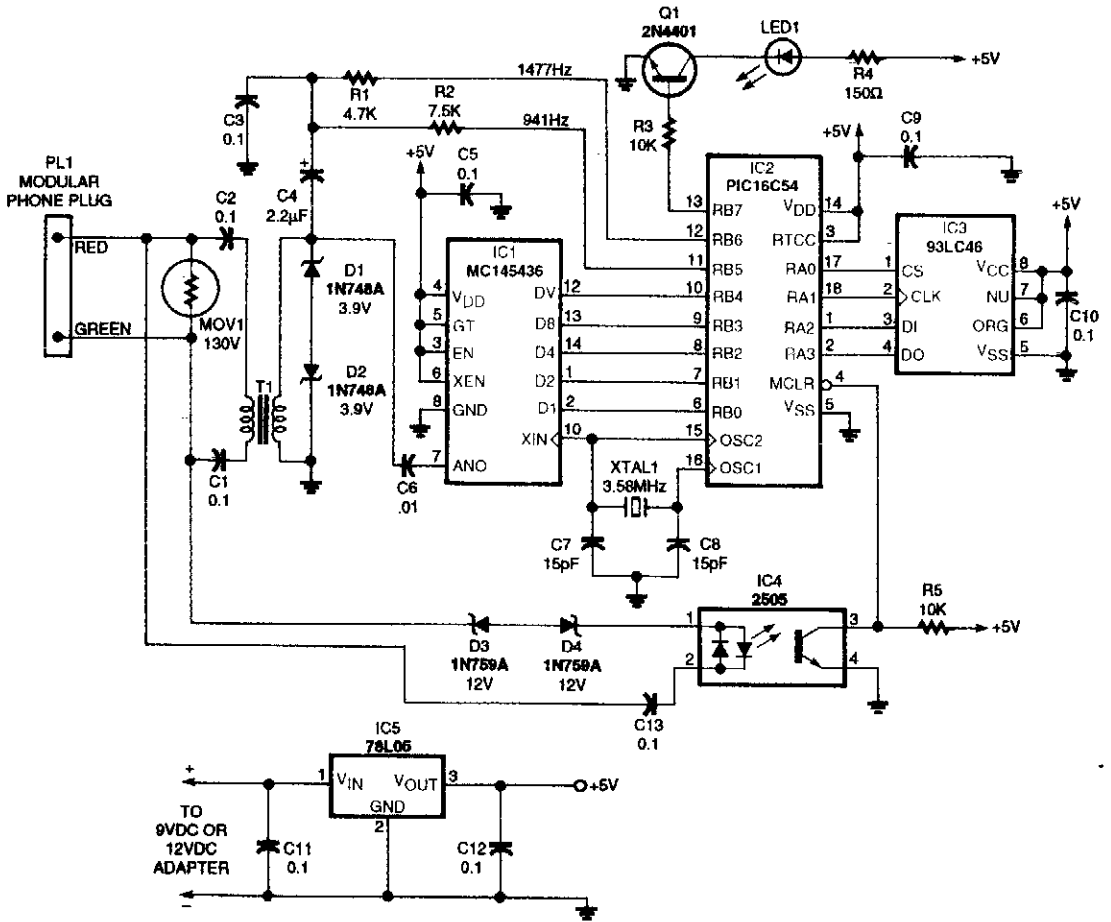

This circuit is designed to restrict phone calls with the area codes: 900, 976, and 540. This device uses a microcontroller to compare the DTMF decoded tones with telephone numbers stored in EEPROM (IC3). This device requires a programmed microcontroller. Software and details of programming can be found in the original magazine article.

TELEPHONE SCRAMBLER

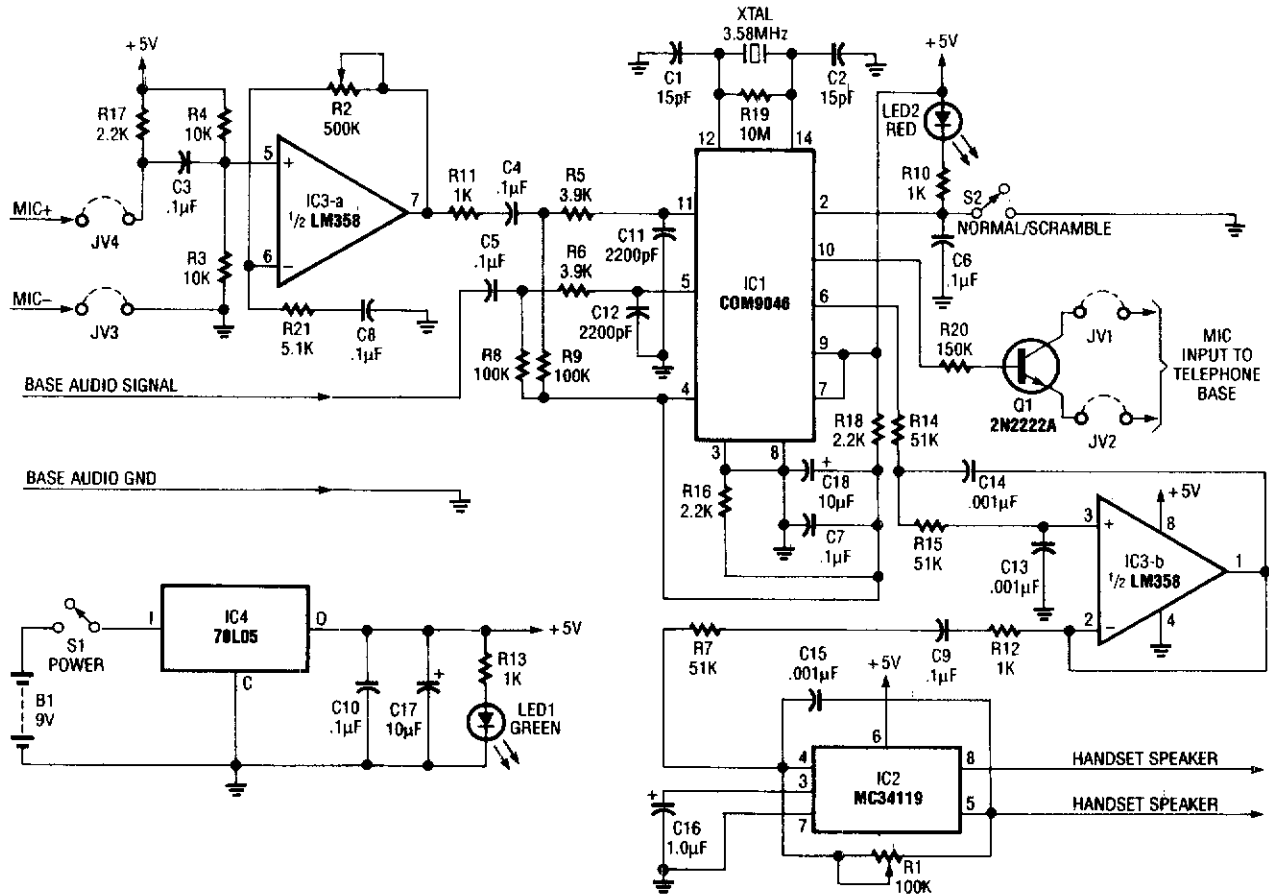

This circuit uses the usual speech inversion algorithm, implementing it with a COM9046 ASIC. This unit is designed to fit between the handset and base of a standard telephone. It is powered by a 9-V battery.

UNIVERSAL TELEPHONE HOLD CIRCUIT

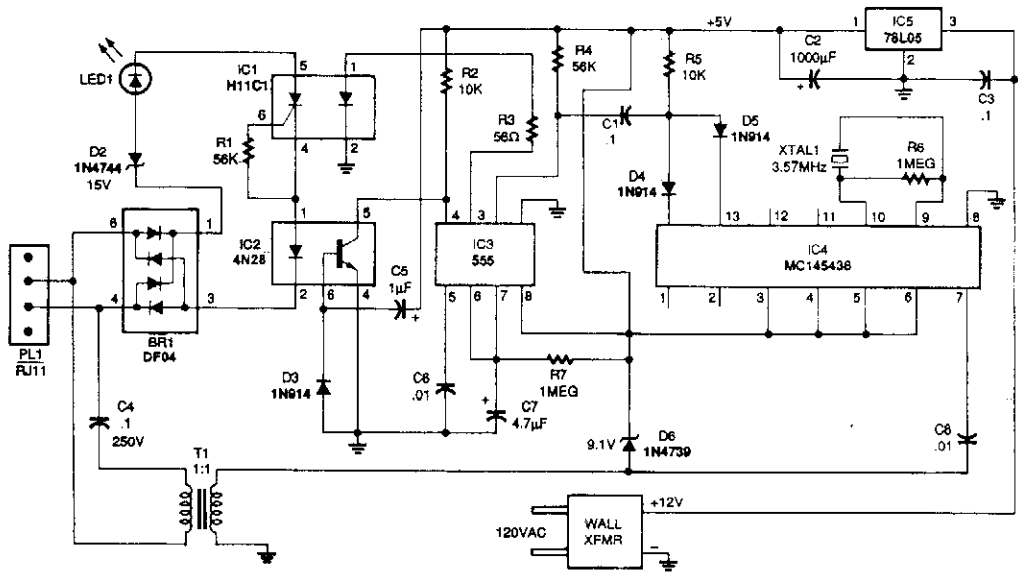

ELECTRONICS NOW

Fig. 90-5

The telephone line is connected to the hold components through bridge rectifier BR1 so that the input is not polarity sensitive. If you have touch-tone telephone service, you can now put a call on hold from any phone in your house by plugging this simple device into any telephone jack. The universal hold-circuit works with any phone that has a key pad with a # key. To put a call on hold, press the # key and hang the phone up. A timer extends the #-key function while you hang up phones that have a keypad built into the handset.

TELEPHONE RING AMPLIFIER

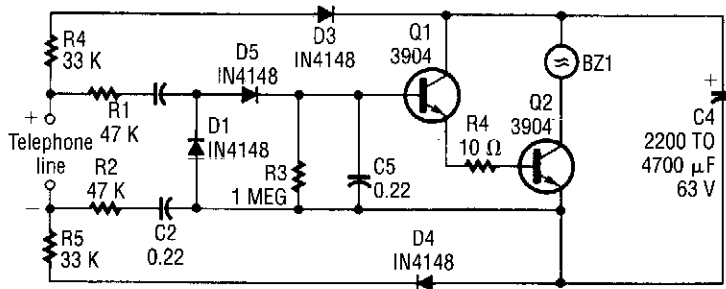

ELECTRONICS NOW

Fig. 90-6

This circuit takes its operating power from the telephone line. BZ1 is a piezoelectric transducer.

BELL SYSTEM 202 DATA ENCODER

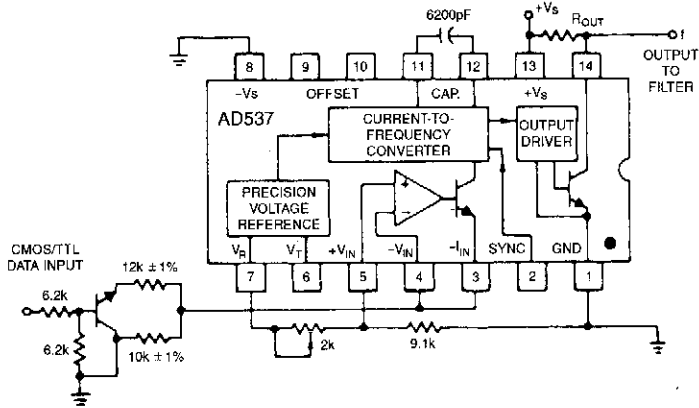

Fig. 90-7

ANALOG DEVICES

The AD537 is well-suited for frequency-shift modulator and demodulator applications. Requiring little power, it is especially appropriate for using phone-line power. The Bell-System 202 data encoder shown here delivers the mark frequency of 1.2 kHz with the data input low. When the input goes high, the timing current increases to 165 μ A and generates the space frequency of 2.2 kHz. The trim shown provides a $\pm 10\%$ range of frequency adjustment. The output goes to the required band-pass filter before transmission over a public telephone line. A complementary demodulator is easy to implement.

TELEPHONE/AUDIO INTERFACE

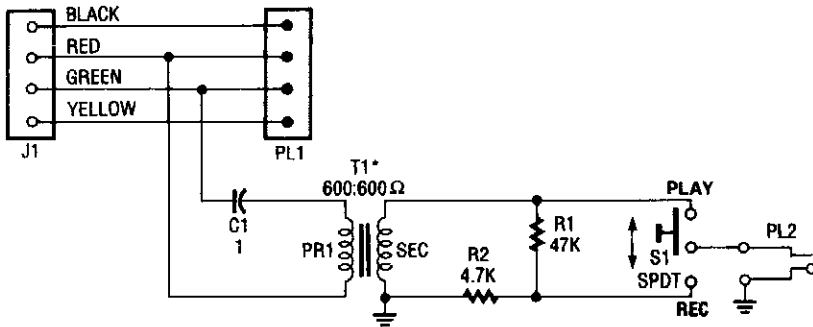
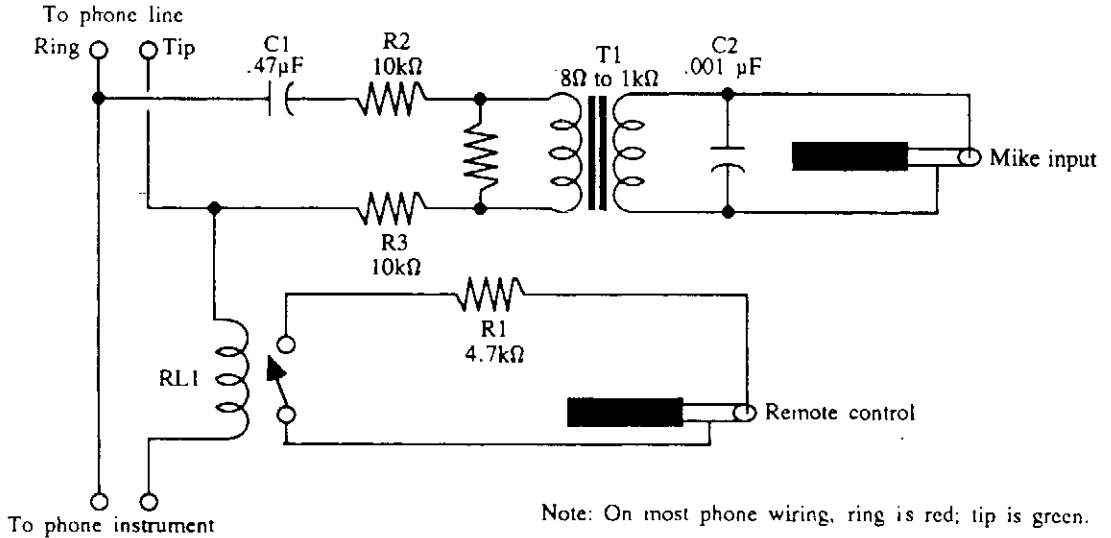

Fig. 90-8

POPULAR ELECTRONICS

The telephone audio interface—essentially, a simple isolation/couple circuit—isolates the phone line from any connected audio circuit without presenting any danger to the phone line, the equipment, or the user.

TELEPHONE RECORDING CIRCUIT



R1	4.7 kΩ
R2,R3	10 kΩ
C1	0.47 µF disc
C2	0.001 µF disc
T1	8 kΩ-to-1 kΩ impedance-matching transformer
RL1	SPST reed relay

All resistors are 5 to 10 percent tolerance, 1/4 watt. All capacitors are 10 to 20 percent tolerance, rated at 35 volts or more.

McGRAW-HILL

Fig. 90-9

This device will automatically record telephone calls. An ordinary cassette recorder can be hooked to it.

TELEPHONE BELL AMPLIFIER

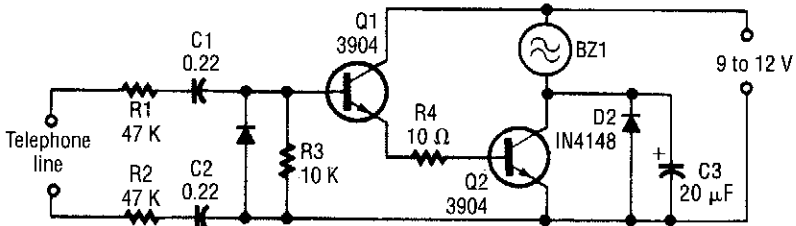

ELECTRONICS NOW

Fig. 90-10

Telephone "bell" amplifier circuit will let you hear (or see) an enhanced alarm if you are away from your telephone.

PHONE LINE SIMULATOR

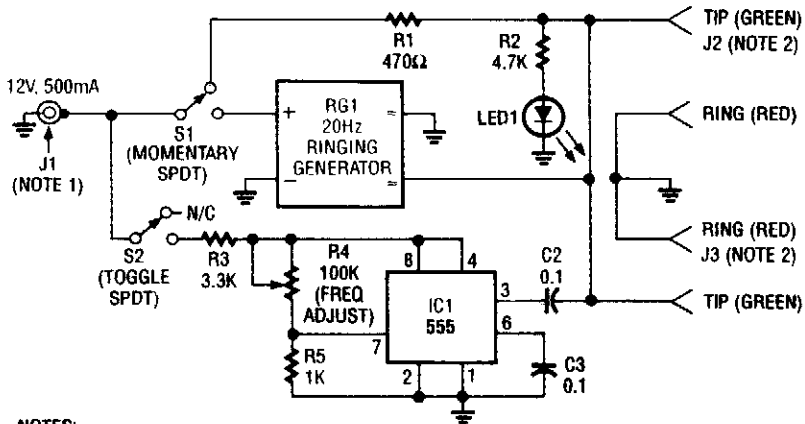

- NOTES:**
 1. MATES WITH AC-TO-DC ADAPTER PLUG
 2. LOCATED IN WALL PLATE

ELECTRONICS NOW

Fig. 90-11

This device contains a ringing generator and a tone oscillator. The tone oscillator is set to either 350 or 440 Hz. The ringing generator is a potted module delivering 86 Vac at 20 Hz. It is available from a source listed in the reference.

PHONE HELPER

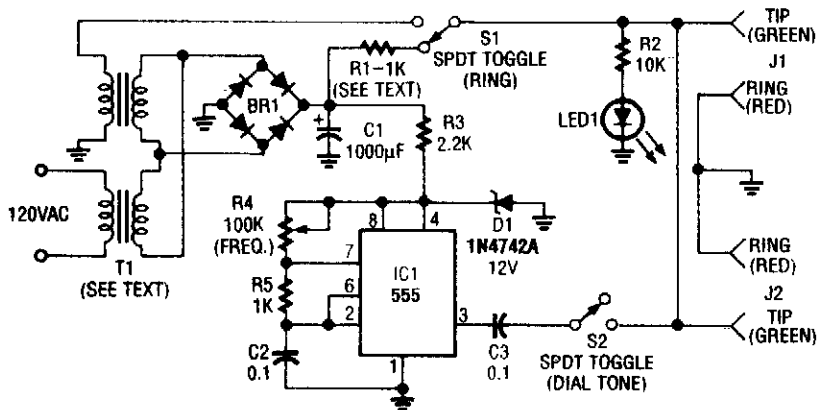

RADIO-ELECTRONICS

Fig. 90-12

This phone-line simulator uses a 60-Hz transformer instead of a ring generator. The dial tone is provided by an NE555 astable oscillator.

TELEPHONE RING SIGNAL DETECTOR

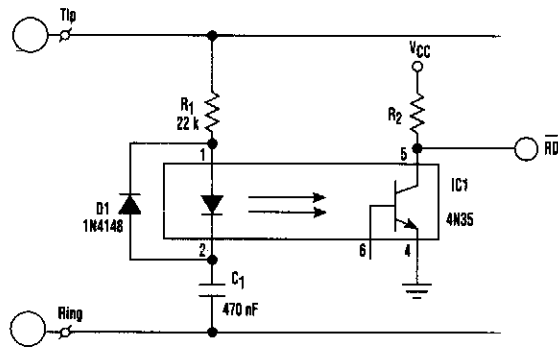

Fig. 90-13

ELECTRONIC DESIGN

Discriminating between telephone-ring signals on a phone line can be accomplished by using dedicated ICs, such as AT&T's LB1006AB or Texas Instruments' TMS1520A. However, if the system already is using a microcontroller, those dedicated chips can be replaced with simpler hardware and a few bytes of code.

Looking at the setup, the ringing voltage pulses the optoisolator's LED; which, in turn, pulses the low-asserted RD line to the microcontroller. The firmware analyzes the pulses to determine whether a valid ringing signal is present.

The frequency limits of a valid signal are 20 to 80 Hz, which is modulated 2 seconds on and 4 seconds off (with distinctive ringing, though, this cadence can vary). Therefore, the simplest analysis is to count down at least 20 pulses of RD in 1 second.

The routine could be expanded to determine what type of ring signal is present in a distinctive ring setting. Such a system could switch the phone line to various output jacks. As a result, several phone devices could use the same line without first picking up the line to determine if it's a voice, fax, or data call.

TELEPHONE HOLD CIRCUIT

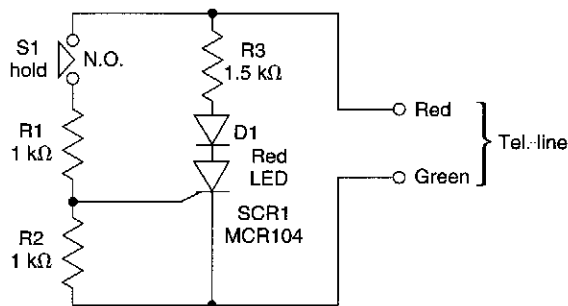

When the hold button S1 is pressed, SCR1 fires via R1 and R2, firing SCR1, and seizing the line via the path through R3, D1, and SCR1.

WILLIAM SHEETS

Fig. 90-14

Temperature-Related Circuits

The sources of the following circuits are contained in the Sources section, which begins on page 707. The figure number in the box of each circuit correlates to the entry in the Sources section.

Electronic Thermostat	Temperature-to-Frequency Converter (Celsius)
Temperature Controller	Temperature-to-Frequency Converter (Kelvin)
Manual Control for Heater	Differential Thermometer
Proportional Temperature Controller	Optoelectronic Pyrometer
Eight-Input A/D Converter for Temperature Measurements	Bar-Graph Room-Temperature Display
Cold Junction Compensation for a Grounded Thermocouple	LM3911 Temperature Controller
Absolute Temperature Log with RS-232	Thermocouple Amplifier with Cold-Junction Compensation
Centigrade Thermometer with Cold-Junction Compensation	Precision RTD Amplifier Circuit for +5 V
1.5-V Electronic Thermometer	Full-Range Fahrenheit Temperature Sensor
Two-Wire Temperature Sensor Output Referenced to Ground	Improved Thermostatic Relay Circuit
Two-Wire Remote Temperature Sensor with Sensor Grounded	Thermocouple Cold-Junction Compensation
Single-Supply Temperature Sensor (-50 to +300°F)	Temperature Differential Detector
Basic Fahrenheit Temperature Sensor	Thermostatic Relay Application
	Temperature Controller
	Temperature-to-Digital-Output Converter
	Freeze-Up Sensor
	Zero-Voltage Switching Temperature Regulator

ELECTRONIC THERMOSTAT

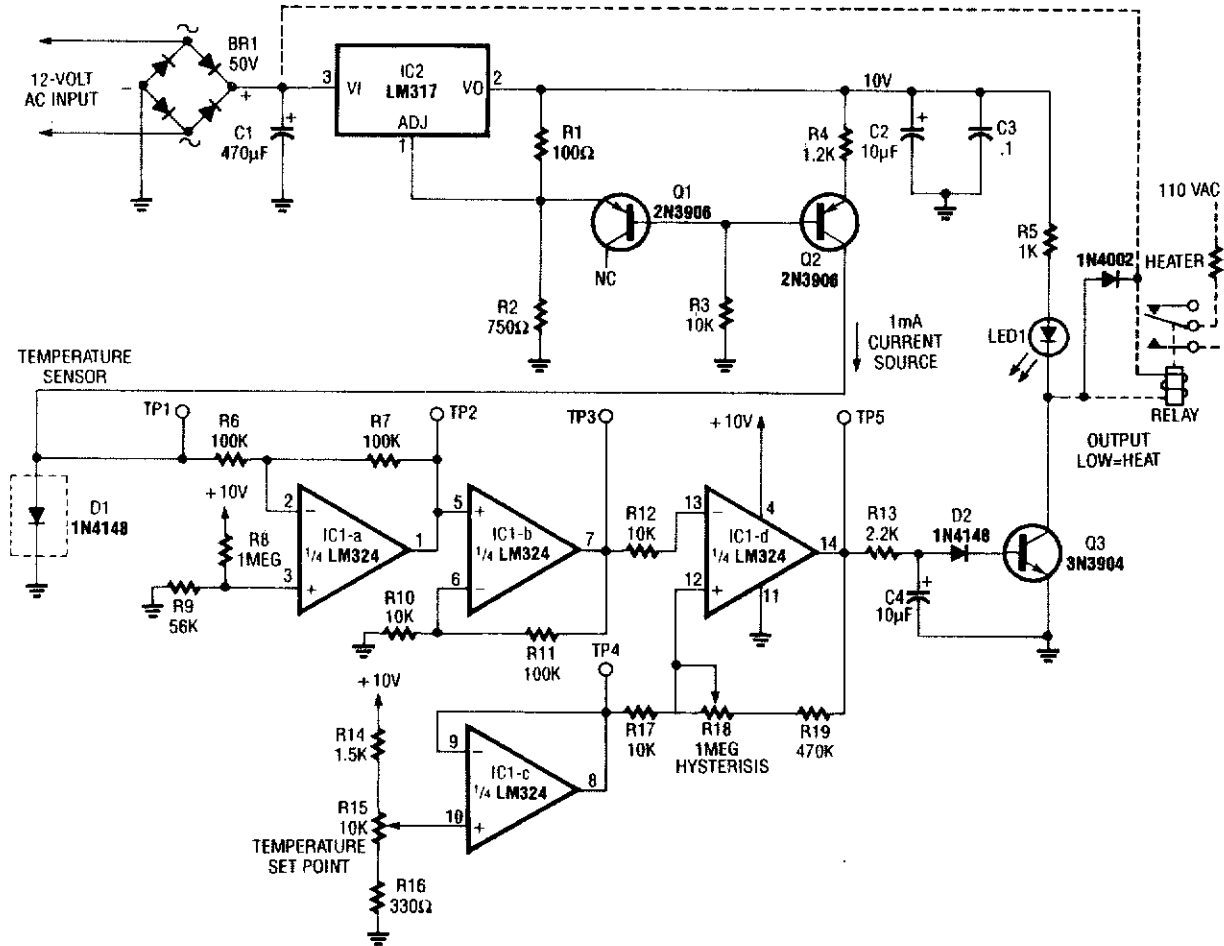

Using a 1N914 diode as a temperature sensor, this straightforward circuit has hysteresis and set-point adjustments. Usable range is about -50 to $+150^{\circ}\text{C}$.

TEMPERATURE CONTROLLER

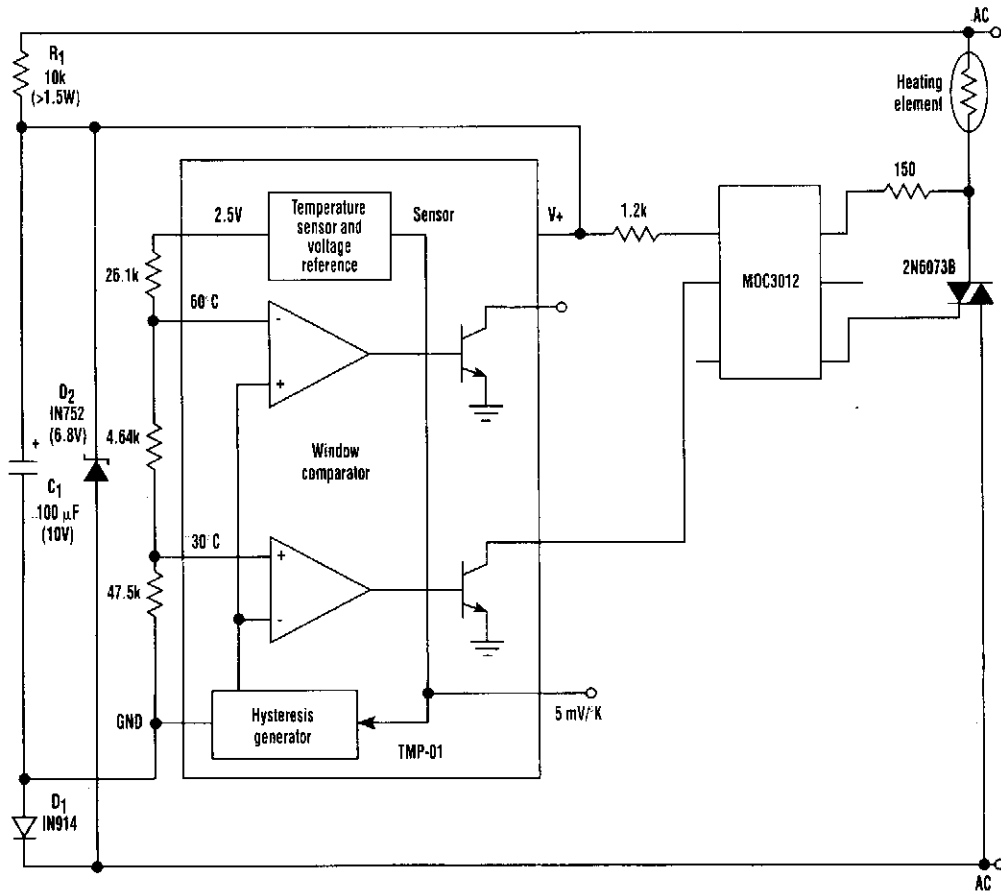

ELECTRONIC DESIGN

Fig. 91-2

The temperature sensor/controller (the TMP-01) is a monolithic device whose low power allows it to operate with a simple half-wave rectified power supply directly from the ac line. Such an arrangement greatly simplifies the power-supply design requirement to the point of only needing a few low-cost components to provide a single +6-Vdc supply.

The TMP-01 is essentially a “thermostat on a chip.” It includes a linear temperature sensor (5 mV/K), and also has two comparators that switch at externally determined set points. These set points are established by resistively dividing the internal 2.5-V reference to set appropriate voltages on the inputs to the comparators.

One comparator is used in this circuit to turn on the heating element when the temperature drops below 30°C; it corresponds to a voltage of 1.52 V on the comparator’s input.

MANUAL CONTROL FOR HEATER

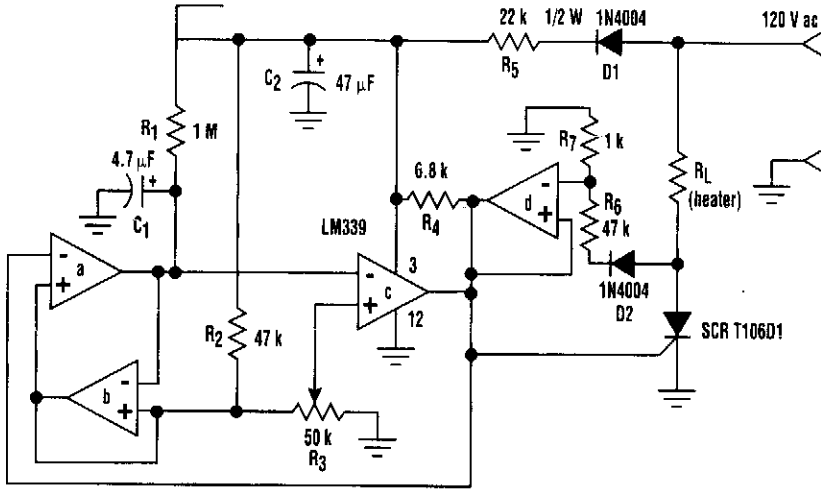

ELECTRONIC DESIGN

Fig. 91-3

Built around an LM339 quad comparator, this circuit provides manual control of the output of a resistive heater or other load with a long time constant. The circuit's design uses minimal parts, thus it's inexpensive, and generates very low RFI.

Comparators a, b, and c form a low-frequency pulse-width modulator. Sections a and b form a sawtooth oscillator (of approximately 0.25 Hz), with capacitor C1 being charged through R1 and discharged through section a's open collector output. R2 and R3 set the upper voltage limit for the sawtooth wave. The hysteresis means that C1 is discharged to nearly 0 V, creating a voltage swing that is identical to the adjustment range of R3.

Comparator c, in conjunction with potentiometer R3, converts the sawtooth wave form to a variable duty-cycle drive for the silicon-controlled rectifier.

Increasing voltage at R3's wiper means increasing the "on" time. Section d holds the SCR gate low if the line voltage is above approximately 3.5 V, preventing turn on at mid-cycle and ensuring low RFI.

The oscillator frequency is roughly determined by $1/0.7R_1C_1$. Resistance R1 must be greater than $4R_2$ or the oscillator will lock up. Reducing R2 will increase the lower voltage limit of the sawtooth; increasing it might cause lock-up.

PROPORTIONAL TEMPERATURE CONTROLLER

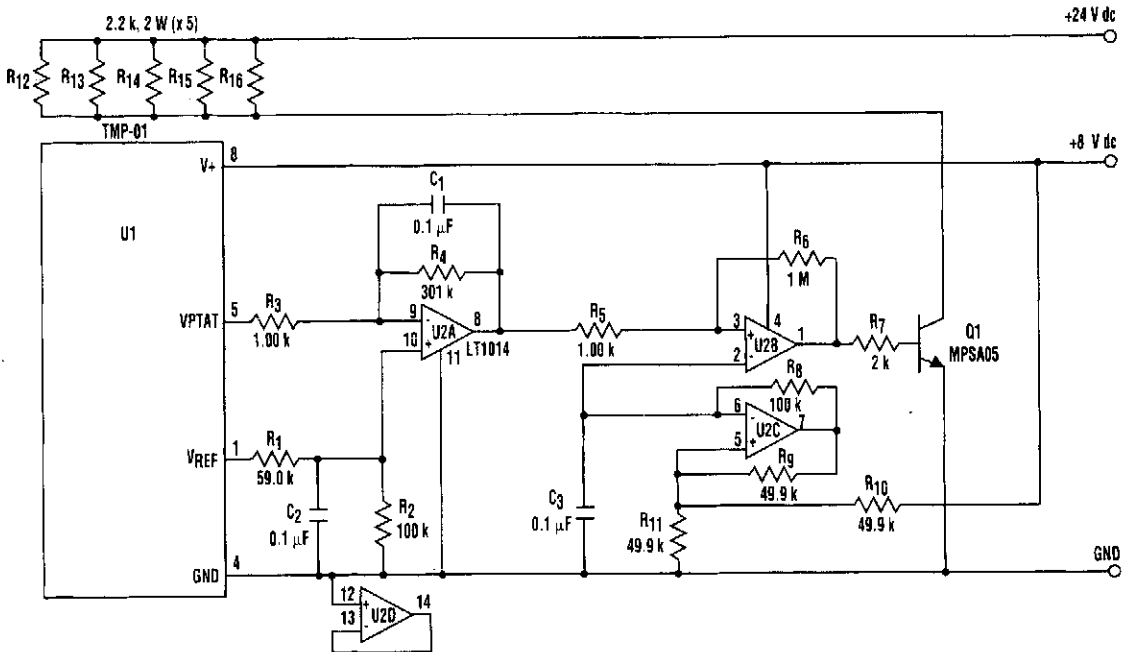

ELECTRONIC DESIGN

Fig. 91-4

Most temperature-controller circuits use upper and lower trip points to control a heater element, with the heater power full on and full off. Usually, this results in a temperature hysteresis of several degrees. This relatively large temperature hysteresis effect might cause modulation in the output of the circuit that's being controlled.

A proportional temperature controller eliminates this problem by continuously providing the power needed to maintain the "oven" at the desired temperature—within 1°C. From a cold start, maximum power is applied until the temperature is within 2°C of the set point.

The circuit's mechanical construction is important. The five heater resistors (R12 through R16), the temperature-sensor IC (U1), and the circuit being controlled are mounted with thermal epoxy to a small piece of aluminum. This provides excellent heat transfer between the components. The heater resistors must be selected to raise the temperature from ambient to the set point within an acceptable warm-up time.

U1 is Analog Devices' TMP-01 temperature-controller IC. The voltage proportional to absolute temperature (VPTAT) has a temperature coefficient of exactly 5 mV/°C. The set point is determined by the R_1/R_2 ratio. U2 is a Linear Technology LT1014 quad precision op amp. U2C is an oscillator with a 50% duty cycle that supplies a triangle wave between $\frac{1}{3}$ and $\frac{2}{3}$ of the supply voltage at U2-2.

U2B compares the amplified VPTAT to the triangle wave, which drives Q1 at a duty cycle of 100% or less. Because the triangle wave's peak-to-peak amplitude is 2.7 V, and VPTAT is amplified by a factor of 300, a temperature change of approximately 2 mV moves the duty cycle from 100% to 0%.

EIGHT-INPUT A/D CONVERTER FOR TEMPERATURE MEASUREMENTS

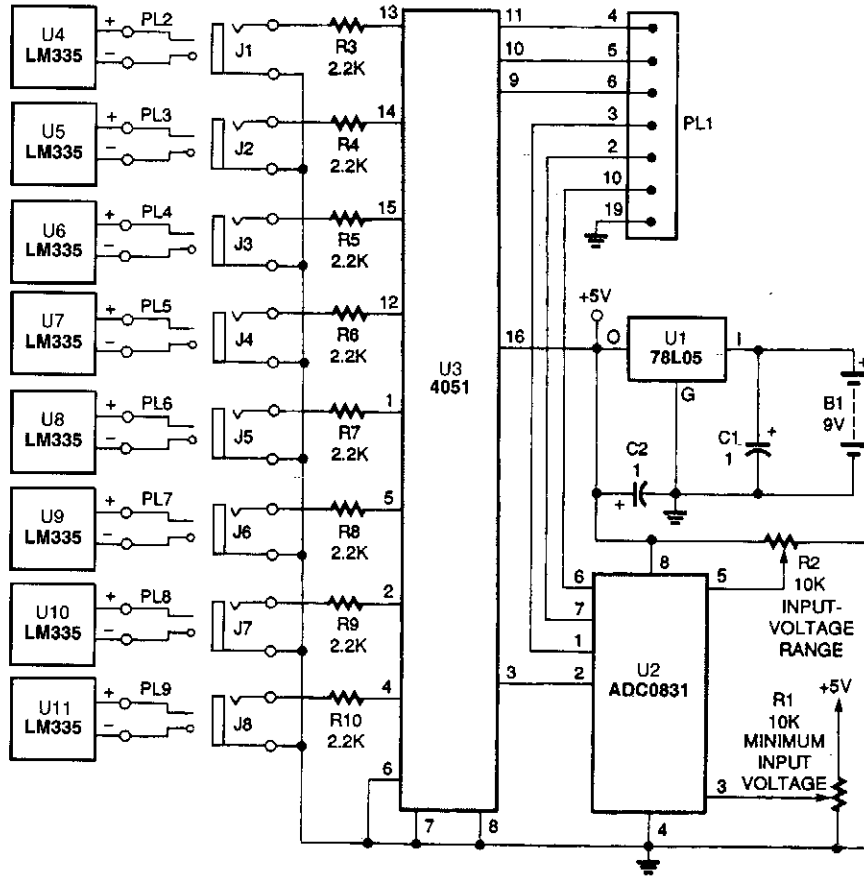

POPULAR ELECTRONICS

Fig. 91-5

The actual processing circuitry of this A/D converter consists of only four parts: U2, U3, R1 and R2. Eight temperature probes are used with the circuit; however, they can be replaced with other types of sensors, as long as resistors R3 through R10 are removed.

EIGHT-INPUT A/D CONVERTER FOR TEMPERATURE MEASUREMENTS (Cont.)

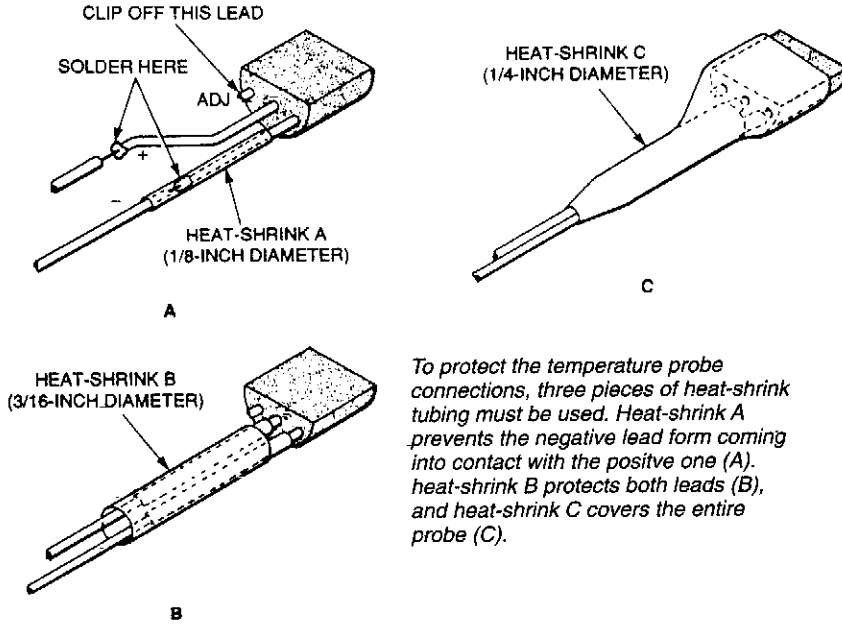

COLD-JUNCTION COMPENSATION FOR A GROUNDED THERMOCOUPLE

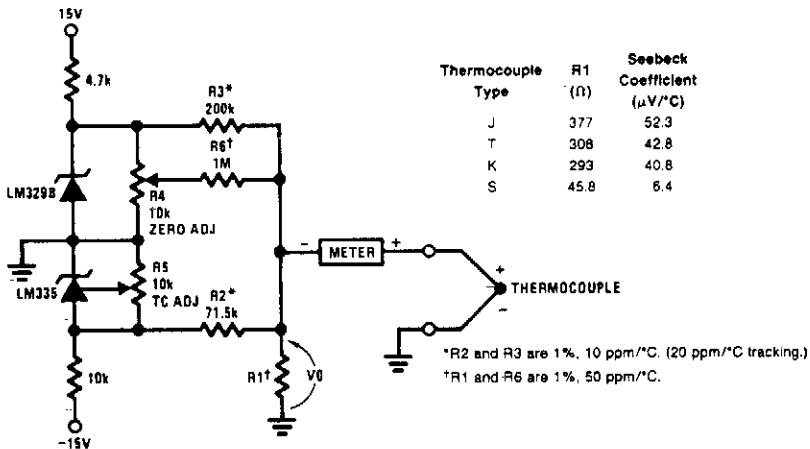

NATIONAL SEMICONDUCTOR

Fig. 91-6

A circuit for use with grounded thermocouples is shown. To trim, short out the LM329B and adjust R5 so that $V^{\circ} = \alpha T$, where α is the Seebeck coefficient of the thermocouple and T is the absolute temperature. Remove the short and adjust R4 so that V° equals the thermocouple output voltage at ambient. A good grounding system is essential here, for any ground differential will appear in series with the thermocouple output.

ABSOLUTE TEMPERATURE LOG WITH RS-232

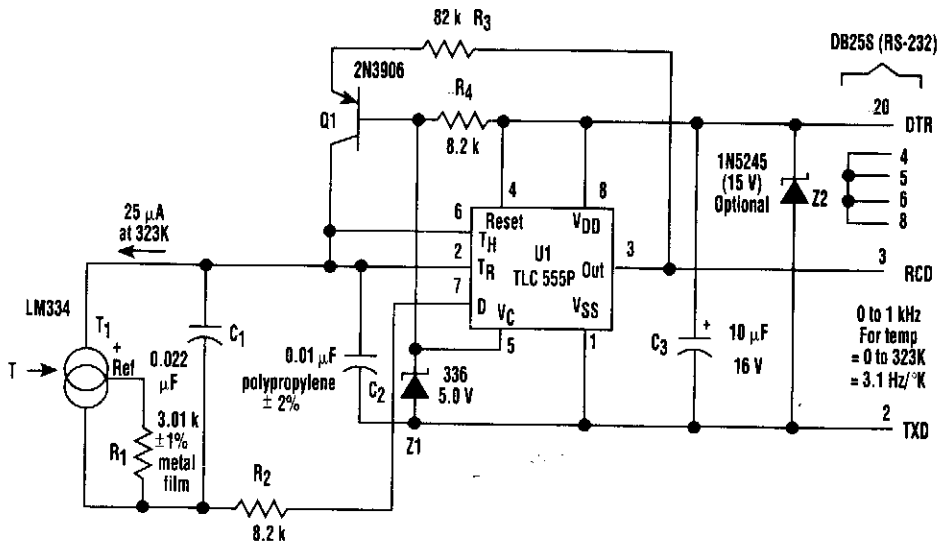

ELECTRONIC DESIGN

Fig. 91-7

In the setup, T1 (an LM334 temperature sensor) generates a constant current that's proportional to absolute temperature, and equal to 25 μ A at 323 Kelvin (50°C). R1 sets this constant of proportionality. The current discharges the parallel combination of C1 and C2 connected to the trigger and the threshold pins of U1, which is a CMOS implementation of the venerable 555 analog timer. The negative-going ramp is compared by U1 to an internal 2.5-V trigger level controlled by Z1. When the ramp gets there, U1 triggers. The output pin (3) will go high, presenting a "start" bit to the connected communications port, which causes Q1 to source 100 μ A to the timing node. At the same time, the discharge pin (7) will open, allowing R2 and the bottom end of C1 and T1 to be supplied by C1, and isolates it from C2.

Consequently, the current supplied by transistor Q1 will go solely to C2 so that when the resulting positive-going ramp reaches 5 V, exactly 25 nC (2.5 V \times C2) will have been deposited in the timing node by the recharge cycle because its threshold level (6) will have been reached. This causes both the output pin to return to the negative rail, restoring the "marking" condition of the R2-232 interface, and Q1 to stop recharging C2. U1's discharge pin (7) now connects R2 to the negative rail, causing the charge that was deposited by T1 on C1 during the recharge interval to rapidly redistribute between C1 and C2. This arrangement creates a very linear (0.01%) relationship between T1 current and pulse output frequency.

While this is happening, the PC's communications port hardware assembles a valid (although meaningless) character because the positive pulse output by U1 looks like the start bit of a character. A simple program running in the PC can then count the frequency of these characters and convert the resulting rate into a direct readout of temperature. Because of the 3.1-Hz/degree slope of frequency versus temperature, a 30-second average suffices for 0.01° resolution.

CENTIGRADE THERMOMETER WITH COLD-JUNCTION COMPENSATION

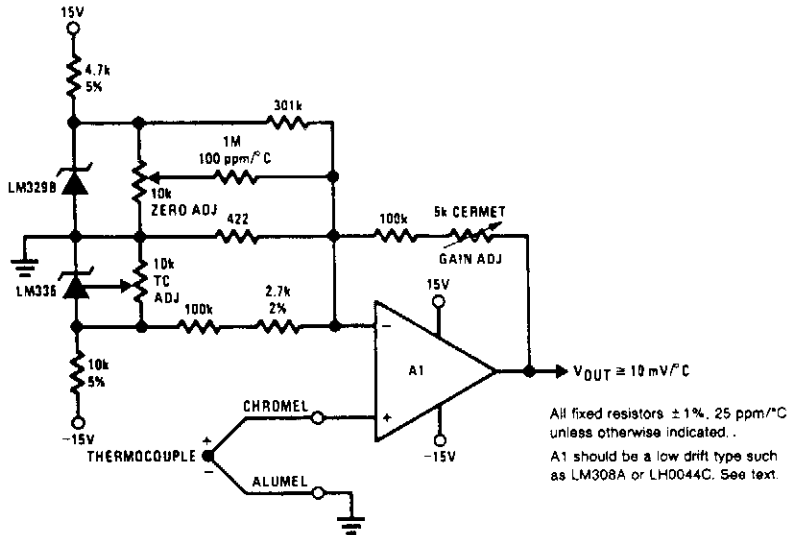

NATIONAL SEMICONDUCTOR

Fig. 91-8

This electronic thermometer has a 10-mV/°C output from 0°C to 1300°C. The trimming procedure is as follows: first short out the LM329B, the LM335 and the thermocouple. Measure the output voltage (equal to the input offset voltage times the voltage gain). Then apply a 50-mV input voltage and adjust the GAIN ADJUST pot until the output voltage is 12.25 V above the previously measured value. Next, short out the thermocouple again and remove the short across the LM335. Adjust the TC ADJUST pot so that the output equals 10 mV/°K times the absolute temperature. Finally, remove the short across the LM329B and adjust the ZERO ADJUST pot so that the output voltage equals 10 mV/°C times the ambient temperature in °C.

1.5-V ELECTRONIC THERMOMETER

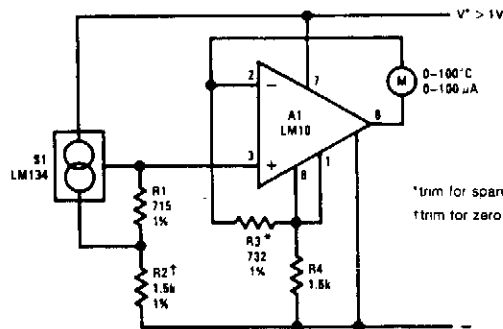

NATIONAL SEMICONDUCTOR

Fig. 91-9

An electronic thermometer design, useful in the range of -55°C to 150°C, is shown. The sensor, S1, develops a current that is proportional to absolute temperature. This is given the required offset and range expansion by the reference and op amp, resulting in a direct readout in either °C or °F.

**TWO-WIRE TEMPERATURE SENSOR
OUTPUT REFERENCED TO GROUND**

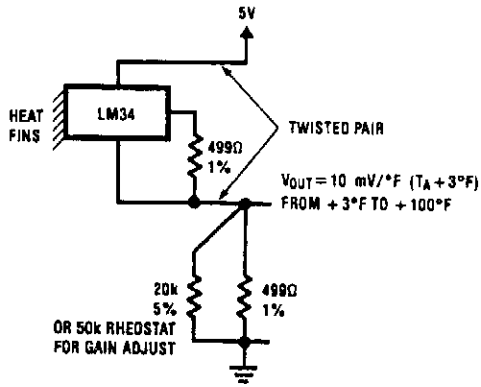

NATIONAL SEMICONDUCTOR

Fig. 91-10

**TWO-WIRE REMOTE TEMPERATURE
SENSOR WITH SENSOR GROUNDED**

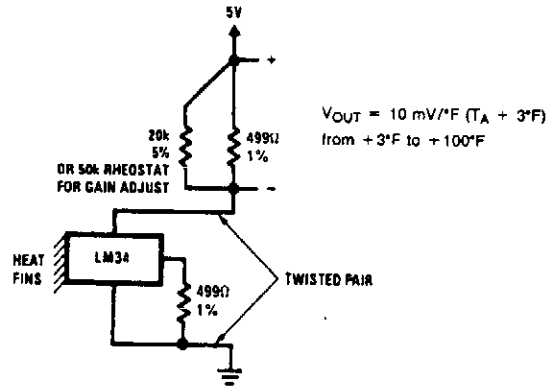

NATIONAL SEMICONDUCTOR

Fig. 91-11

**SINGLE-SUPPLY
TEMPERATURE SENSOR (-50 TO $+300^{\circ}\text{F}$)**

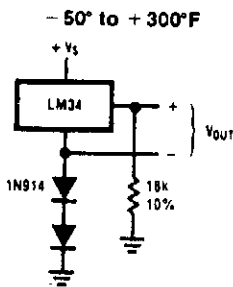

NATIONAL SEMICONDUCTOR

Fig. 91-12

**BASIC FAHRENHEIT
TEMPERATURE SENSOR**

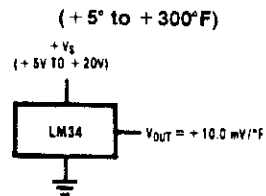

NATIONAL SEMICONDUCTOR

Fig. 91-13

TEMPERATURE-TO-FREQUENCY CONVERTER (CELSIUS)

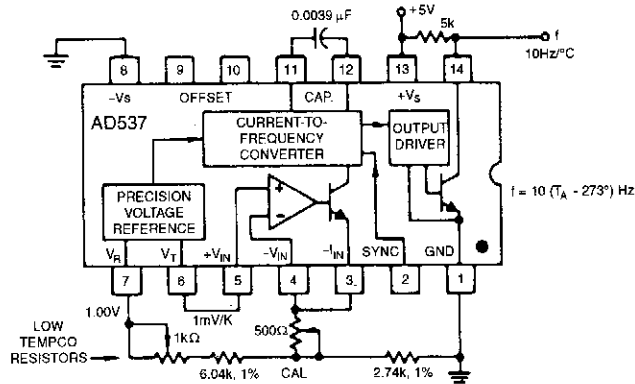

ANALOG DEVICES

Fig. 91-14

The 1.00-V reference output can be combined with the 1-mV/°K output to realize various temperature scales. For the Celsius scale, the lower end of the timing resistor must be offset by 273 mV. This is easily accomplished, and it results in an output from 0 to 1 kHz for temperatures from 0°C to +100°C. Other offsets and scale factors are equally easy to implement.

TEMPERATURE-TO-FREQUENCY CONVERTER (KELVIN)

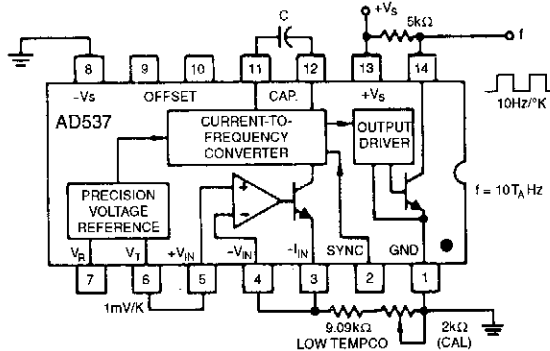

ANALOG DEVICES

Fig. 91-15

This simple connection results in a direct conversion of temperature to frequency. The 1-mV/°K temperature output serves as the input to the buffer amplifier, and the oscillator drive current is scaled to be 298 μ A at 298°K (+25°C). Use of a 1000-pF capacitor results in a corresponding frequency of 2.98 kHz. A single-point trim for calibration is normally sufficient to give errors less than $\pm 2^\circ\text{C}$ from -55°C to $+125^\circ\text{C}$. An NPO capacitor is preferred to minimize nonlinearity that results from capacitance drift.

DIFFERENTIAL THERMOMETER

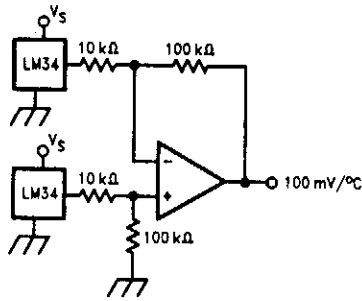

The differential thermometer shown in the figure produces an output voltage which is proportional to the temperature difference between two sensors. This is accomplished by using a difference amplifier to subtract the sensor outputs from one another and then multiplying the difference by a factor of 10 to provide a single-ended output of 100 mV per degree of differential temperature.

NATIONAL SEMICONDUCTOR

Fig. 91-16

OPTOELECTRONIC PYROMETER

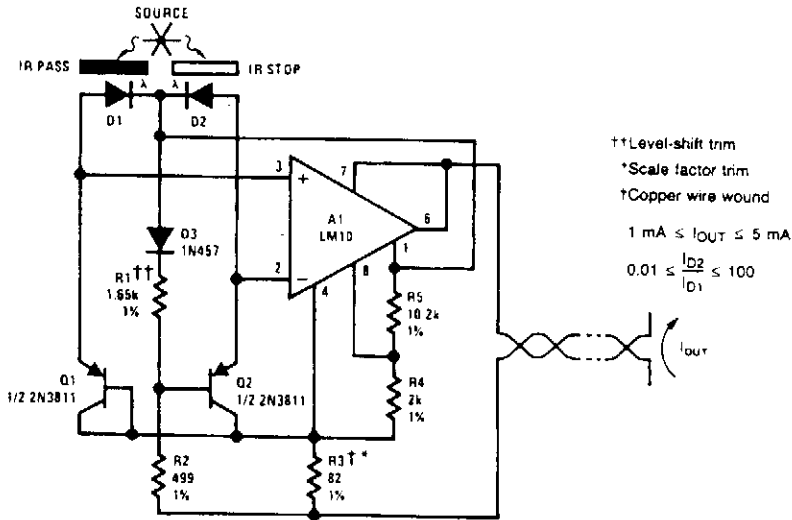

NATIONAL SEMICONDUCTOR

Fig. 91-17

This setup optically measures the temperature of an incandescent body. It makes use of the shift in the emission spectrum of a black body toward shorter wavelengths, as temperature is increased. Optical filters are used to split the emission spectrum, with one photodiode being illuminated by short wavelengths (visible light) and the other by long (infrared). The photocurrents are converted to logarithms by Q1 and Q2. These are subtracted to generate an output that varies as the log of the ratio of the illumination intensifies. Thus, the circuit is sensitive to changes in spectral distribution, but not intensity.

THERMOCOUPLE AMPLIFIER WITH COLD-JUNCTION COMPENSATION

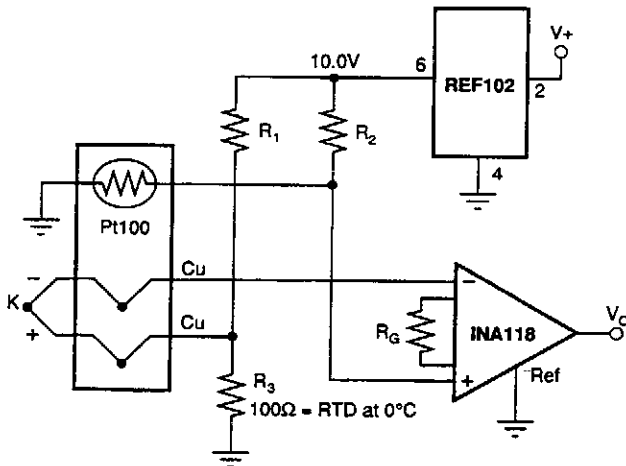

DESIRED GAIN	R _C (Ω)	NEAREST 1% R _C (Ω)
1	NC	NC
2	50.00k	49.9k
5	12.50k	12.4k
10	5.556k	5.62k
20	2.632k	2.61k
50	1.02k	1.02k
100	505.1	511
200	251.3	249
500	100.2	100
1000	50.05	49.9
2000	25.01	24.9
5000	10.00	10
10000	5.001	4.99

ISA TYPE	MATERIAL	SEEBECK COEFFICIENT (μV/°C)	R ₁ , R ₂
E	+ Chromel	58.5	66.5kΩ
	- Constantan		
J	+ Iron	50.2	76.8kΩ
	- Constantan		
K	+ Chromel	39.4	97.6kΩ
	- Alumel		
T	+ Copper	38.0	102kΩ
	- Constantan		

BURR-BROWN

Fig. 91-20

TEMPERATURE DIFFERENTIAL DETECTOR

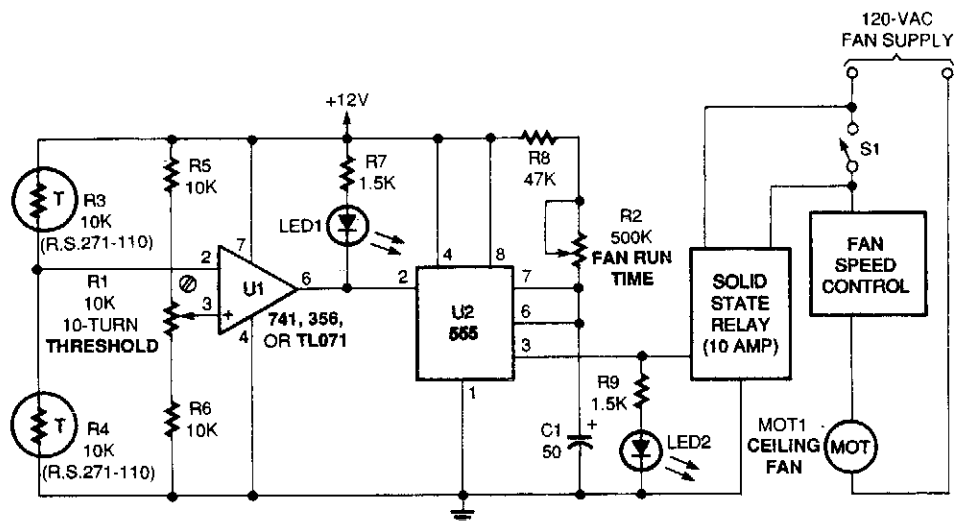

POPULAR ELECTRONICS

Fig. 91-25

This circuit measures temperature differences, not temperature. Once the difference passes a certain threshold, the timer is triggered, activating the solid-state relay.

Op amp U1 is placed in a comparator configuration with two thermistors—one located at the ceiling, one at the floor. The IC senses the temperature difference between the ceiling and floor, but is unaffected by the overall room temperature differential increases. The upper thermistor will decrease in resistance, eventually causing the voltage at pin 2 of U1 to exceed that pin 2 of U1 to go low and trip the timer. This adds hysteresis to the op amp's output, preventing the motor from chattering. When tripped, the timer activates the relay, which activates the fan.

THERMOSTATIC RELAY APPLICATION

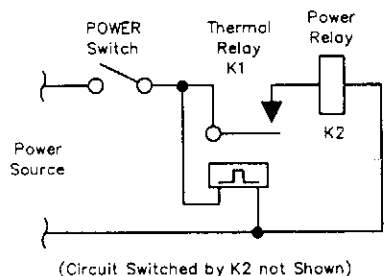

K1, the thermostatic relay, energizes power relay K2, which handles the circuit's power switching. The drawing doesn't show K2's power-switching contacts.

QST

Fig. 91-26

FREEZE-UP SENSOR

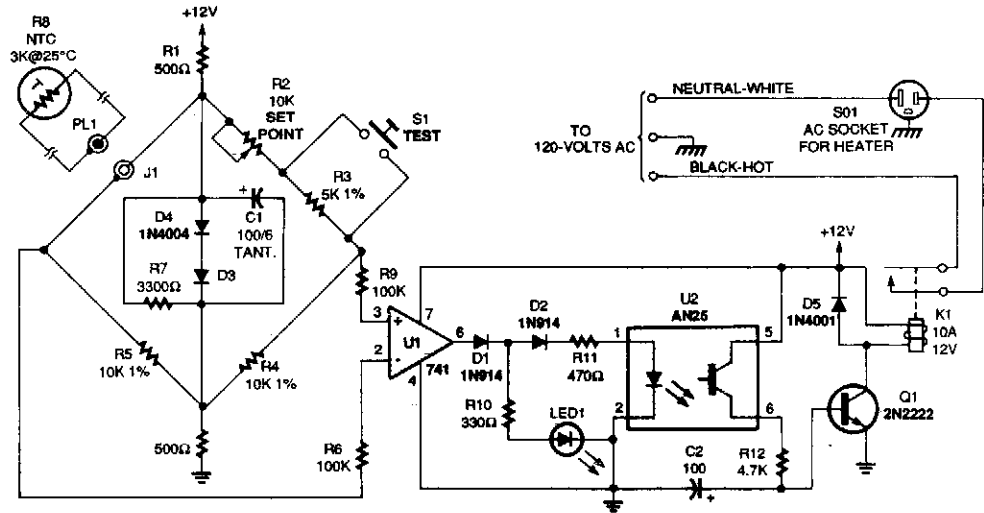

POPULAR ELECTRONICS

Fig. 91-29

Using a bridge circuit to provide an accurate activation temperature, this circuit will turn on a heating unit or other device when the temperature drops below the trip point set by R2. Use a 10-k- Ω resistor in place of the thermistor to calibrate it for 32°F activation.

ZERO-VOLTAGE SWITCHING TEMPERATURE REGULATOR

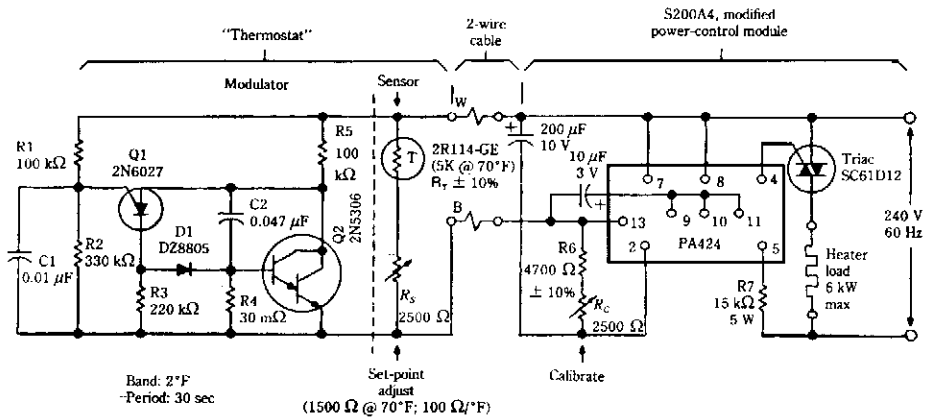

McGRAW-HILL

Fig. 91-30

In this arrangement, an integral number of cycles of ac is fed to the heater. No RFI or EMI is generated with this method. The thermostat uses a thermistor as a sensor. The PA424 (GE) device generates trigger pulses for the triac only at zero crossings of the ac line cycle.

92

Timer Circuits

The sources of the following circuits are contained in the Sources section, which begins on page 707. The figure number in the box of each circuit correlates to the entry in the Sources section.

Alarm Clock Timer
Lamp Timer
Long-Period Timer

ALARM CLOCK TIMER

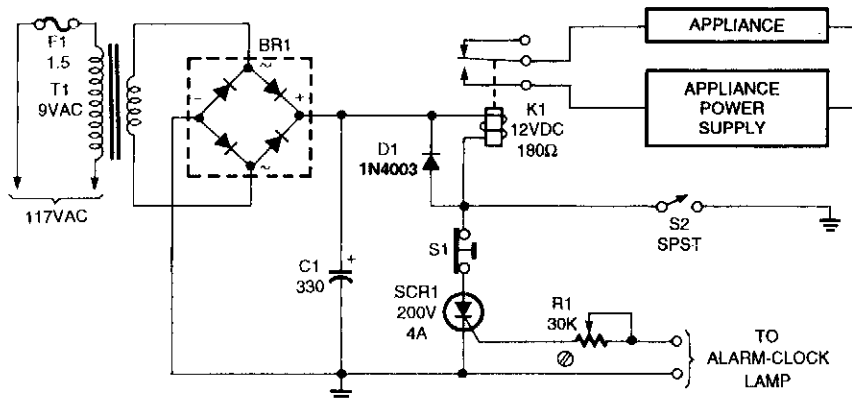

POPULAR ELECTRONICS

Fig. 92-1

Turn your alarm clock into a specialized timer with this simple circuit. The clock used with the circuit should be the kind that turns on a little lamp when the alarm is activated.

LAMP TIMER

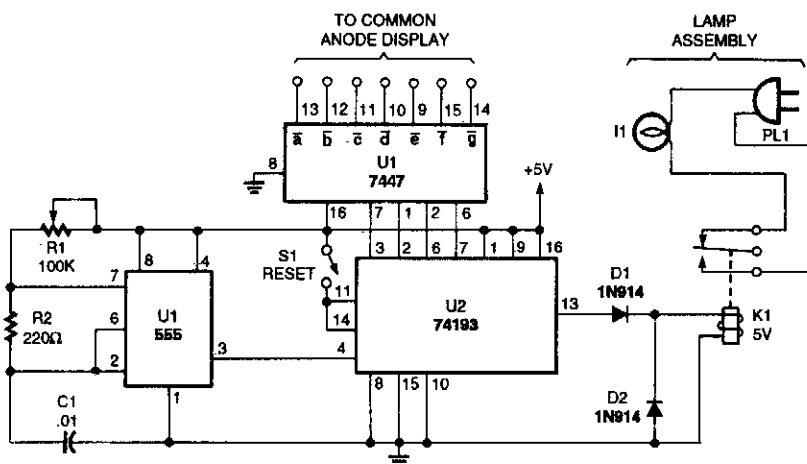

POPULAR ELECTRONICS

Fig. 92-2

A timed switch uses a 555 oscillator/timer wired to operate in the astable mode. The timer supplies a positive pulse to the clock input of a 74193 4-bit binary up/down counter every five minutes. Because the 74193 is set to operate in the count-down mode, the output of the 555 is connected to the count-down input of the 74193.

As the binary counter is reset, it starts counting at nine and counts down to zero with each clock pulse. When the counter hits zero, the output from the 74193 goes low, turning off the relay and the light. The light can be turned back on by pressing the reset button again.

LONG-PERIOD TIMER

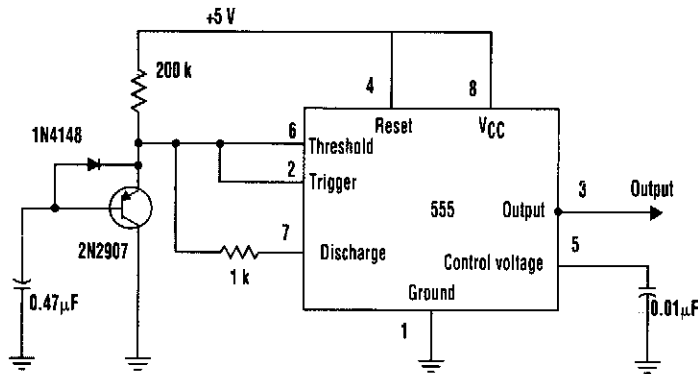

ELECTRONIC DESIGN

Fig. 92-3

Adding a transistor to the 555 timer can create long timer periods, which is a key factor when the timer is operating at low speed. The transistor basically acts as a current divider or capacitance multiplier. The problem with low speed, however, is that the timing resistors and capacitors must be large and the charging current must be small, particularly when the desired timing period is in the range of seconds.

Typically, electrolytic capacitors are used in these situations, but their leakage current tends to aggravate or even prohibit operation at very low charging currents.

This problem can be solved by adding a transistor. In effect, the transistor is used as a current divider or a capacitance multiplier. The normal charging current (emitter current) is divided by the transistor's current gain so that the capacitor charging current (base current) is reduced considerably. For example, 10 μA of emitter current will require approximately 0.1 μA of base current, based on a current gain of 100.

In this circuit, the capacitor will be charged with such a low charging current that timing periods will typically be 100 times longer than usual. This means that substantial time periods can be achieved with film or ceramic capacitors that have much better leakage characteristics and are physically smaller.

The circuit's output period was approximately 6 seconds, compared to 80 ms without the transistor. The transistor multiplied the normal time period by a factor of approximately 75.

93

Tone Control Circuits

The sources of the following circuits are contained in the Sources section, which begins on page 707. The figure number in the box of each circuit correlates to the entry in the Sources section.

Treble-Control Circuit
Bass Tone-Control Circuit
Combined Bass and Treble Control
Active Bass- and Treble-Tone Control

TREBLE-CONTROL CIRCUIT

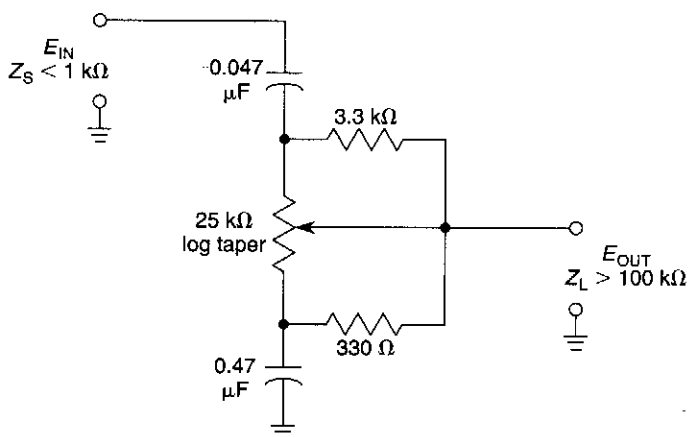

WILLIAM SHEETS

Fig. 93-1

This tone control has an insertion loss of 20 dB at flat setting and is effective above 1 kHz. It has little effect below about 1 kHz.

BASS TONE-CONTROL CIRCUIT

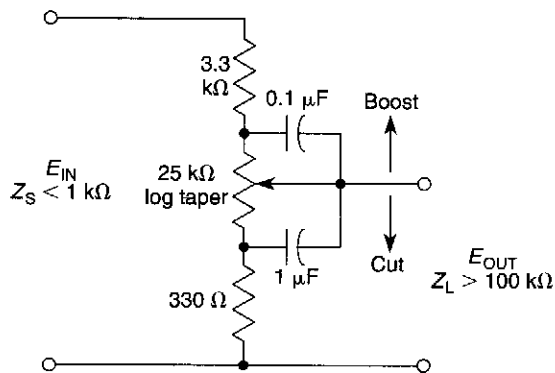

WILLIAM SHEETS

Fig. 93-2

This tone control has an insertion loss of 20 dB at flat setting and is effective below 350 Hz. The control has little effect above this frequency.

COMBINED BASS AND TREBLE CONTROL

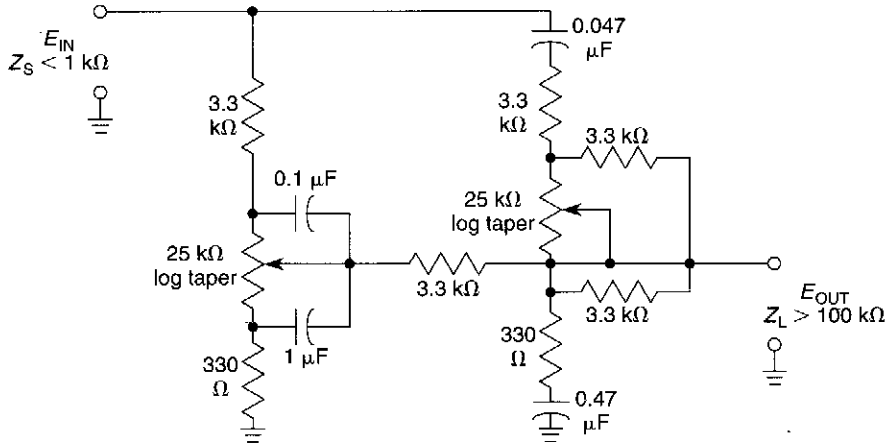

WILLIAM SHEETS

Fig. 93-3

This positive tone control system uses two pots to control bass and treble.

ACTIVE BASS- AND TREBLE-TONE CONTROL

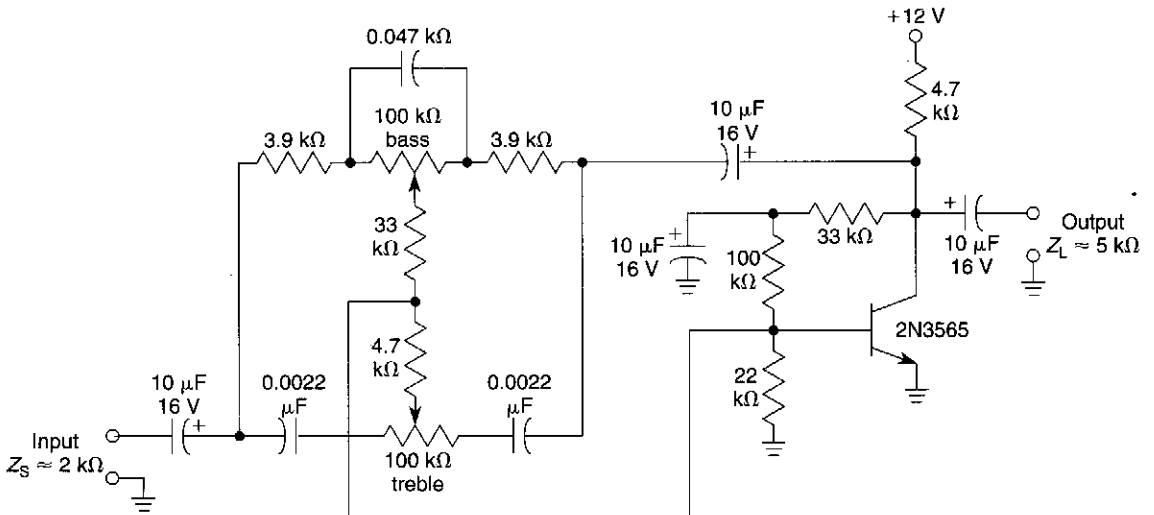

WILLIAM SHEETS

Fig. 93-4

A single transistor used as a feedback amplifier is connected with ac feedback through the tone controls, which determine the frequency response of the stage.

94

Touch/Proximity Control Circuits

The sources of the following circuits are contained in the Sources section, which begins on page 707. The figure number in the box of each circuit correlates to the entry in the Sources section.

Simple Touch Switch
Simple Timed Touch Switch
Capacitive Sensor System
Touch Switch
Proximity Alarm

SIMPLE TOUCH SWITCH

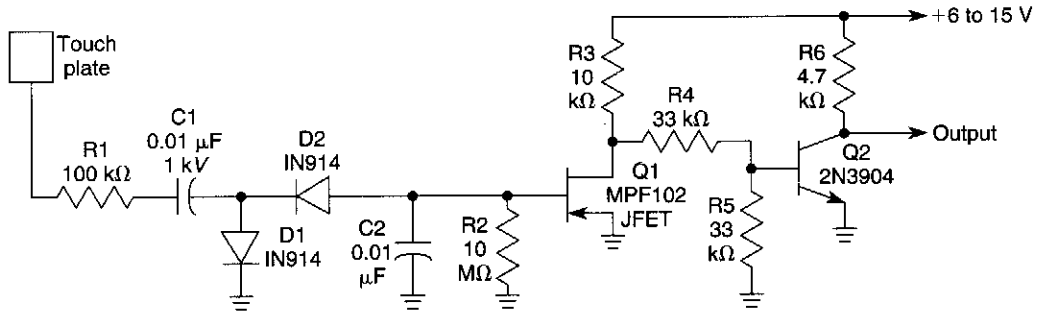

WILLIAM SHEETS

Fig. 94-1

Q2 is held cut off since Q1 normally is conducting. When the touch plate is contacted by a large object (human body, etc.), stray 60-Hz pickup is rectified by D1 and D2, and produces a negative voltage across R2-C2 and the gate of Q1. Q1 cuts off, causes Q2 to conduct, and the output goes low.

SIMPLE TIMED TOUCH SWITCH

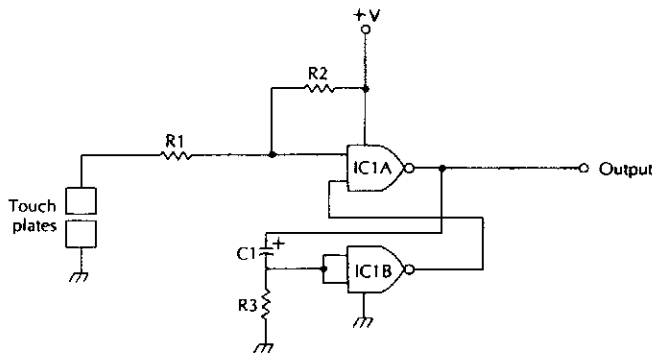

McGRAW-HILL

Fig. 94-2

This circuit produces an output for a time approximately equal to time constant R_3C_1 .

IC1, IC2	CD4011 quad NAND gate
IC3	CD4066 quad bilateral switch
C1	47- μ F, 25-V electrolytic capacitor
C2	100- μ F, 25-V electrolytic capacitor
C3	220- μ F, 25-V electrolytic capacitor
C4	470- μ F, 25-V electrolytic capacitor
C5, C6, C7	0.1- μ F capacitor
R1, R3, R4, R6	100-k Ω , 1/4-W 5% resistor
R7, R9, R10, R12	
R2, R5, R8, R11	10-M Ω , 1/4-W 5% resistor

CAPACITIVE SENSOR SYSTEM

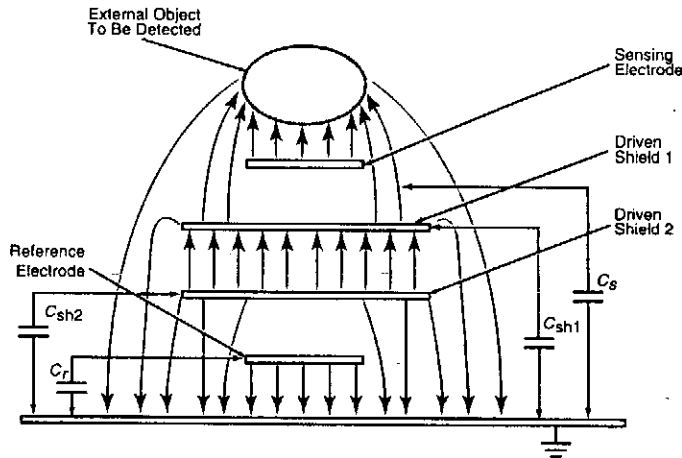

NASA TECH BRIEFS

Fig. 94-3

This figure illustrates the electric-field configuration of a capacitive proximity sensor of the "capaciflector" type. It includes a sensing electrode driven by an alternating voltage, which gives rise to an electric field in the vicinity of the electrode; an object that enters the electric field can be detected by its effect on the capacitance between the sensing electrode and electrical ground.

Also, it includes a shielding electrode (in this case, driven shield 1), which is excited via a voltage follower at the same voltage as that applied to the sensing electrode to concentrate more of the electric outward from the sensing electrode, increasing the sensitivity and range of the sensor. Because the shielding electrode is driven via a voltage follower, it does not present a significant electrical load to the source of the alternating voltage.

In this case, the layered electrode structure also includes a reference electrode adjacent to ground, plus a second shielding electrode (driven shield 2), which is excited via a voltage follower at the same voltage as that applied to the reference electrode. Driven shield 2 isolates the reference electrode from the electric field generated by driven shield 1 and the sensing electrode so that a nearby object exerts no capacitive effect on the reference electrode.

The excitation is supplied by a crystal-controlled oscillator and applied to the sensing and reference electrodes via a bridge circuit. Fixed capacitors C_1 and C_2 (or, alternatively, fixed resistors R_1 and R_2) are chosen to balance the bridge; that is, to make the magnitude of the voltage at sensing-electrode node S equal the magnitude of the voltage at reference-electrode node R.

The voltages at S and R are peak-detected and fed to a differential amplifier, which puts out voltage V_u proportional to the difference between them. When no object intrudes into the electric field of the sensing electrode, the bridge remains in balance, and $V_u = 0$. When an object intrudes, it changes C_s , unbalances the bridge, and causes V_u to differ from zero. The closer the object comes to the sensing electrode, the larger (V_u) becomes.

An additional output voltage KV_r is available, where K is the amplification and V_r is the voltage on the reference electrode.

TOUCH SWITCH

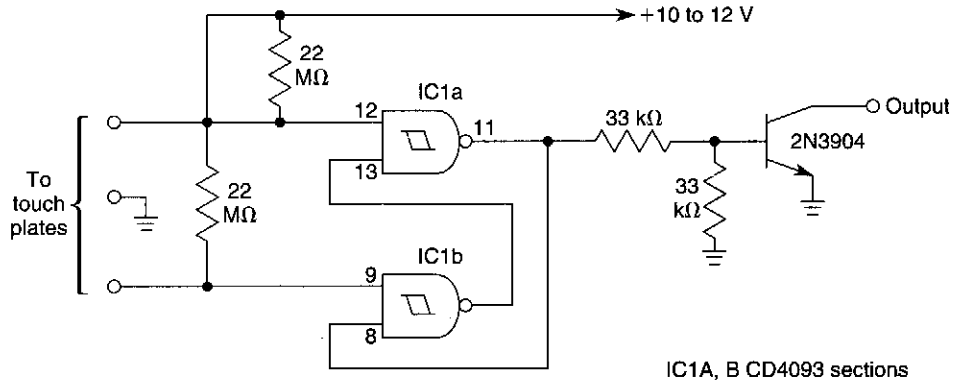

WILLIAM SHEETS

Fig. 94-4

Two NAND Schmitt triggers are used as a flip-flop to produce a bridged touch switch.

PROXIMITY ALARM

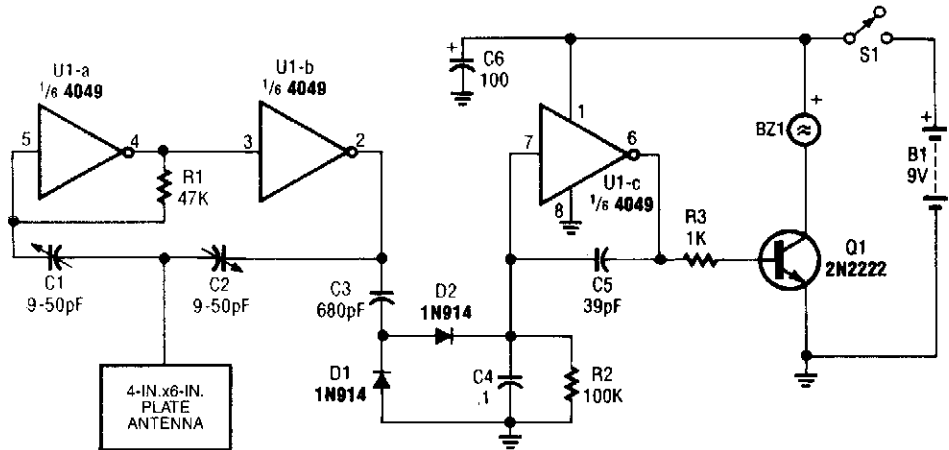

POPULAR ELECTRONICS

Fig. 94-5

95

Tracer Circuits

The sources of the following circuits are contained in the Sources section, which begins on page 707. The figure number in the box of each circuit correlates to the entry in the Sources section.

Wire Tracer
Cable Tracer
Signal Tracer

WIRE TRACER

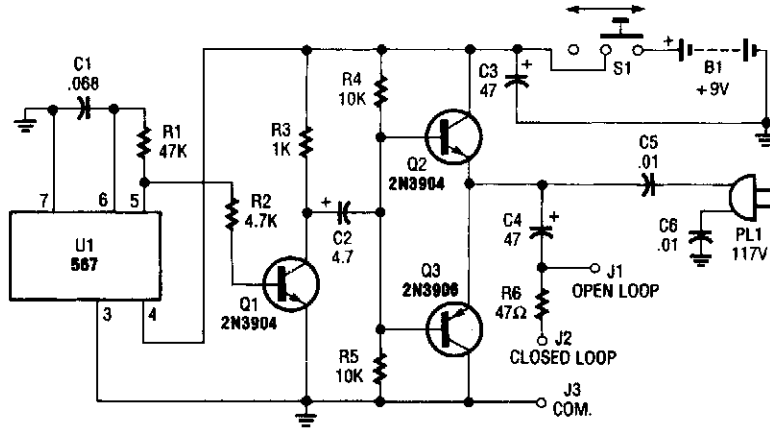

At the heart of the McTrak is a 567 tone decoder, configured as a simple squarewave oscillator, operating at about 250 Hz.

ELECTRONICS HOBBYIST HANDBOOK

Fig. 95-1

This tracer works by placing a square-wave signal on the line to be traced. The square wave is rich in harmonics. A small transistor radio placed close to a wire carrying this signal will buzz. The radio, therefore, is used as a probe to trace out the wire.

CABLE TRACER

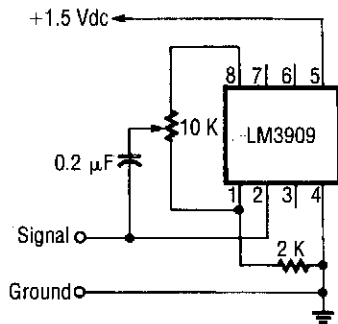

ELECTRONICS NOW

Fig. 95-2

This circuit generates a 1-kHz square wave for cable tracing. Because this circuit is simple and generates from 1.5 V, several can be used at the same time to generate multiple tones for tracing multiconductor cables.

SIGNAL TRACER

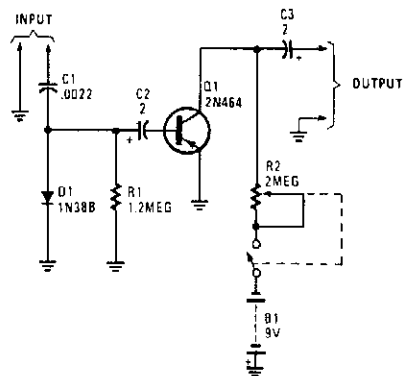

POPULAR ELECTRONICS

Fig. 95-3

This circuit uses a simple detector-audio amplifier. The output can be connected to headphones or another audio amplifier.

96

Transmitter and Transceiver Circuits

The sources of the following circuits are contained in the Sources section, which begins on page 707. The figure number in the box of each circuit correlates to the entry in the Sources section.

Wireless Guitar Transmitter
Micro TV Transmitter
Wireless Microphone
FM Stereo Transmitter
FM Bug
Low-Power VHF Beacon Transmitter
Low-Cost 6-W, 40-M CW Transmitter

WIRELESS GUITAR TRANSMITTER

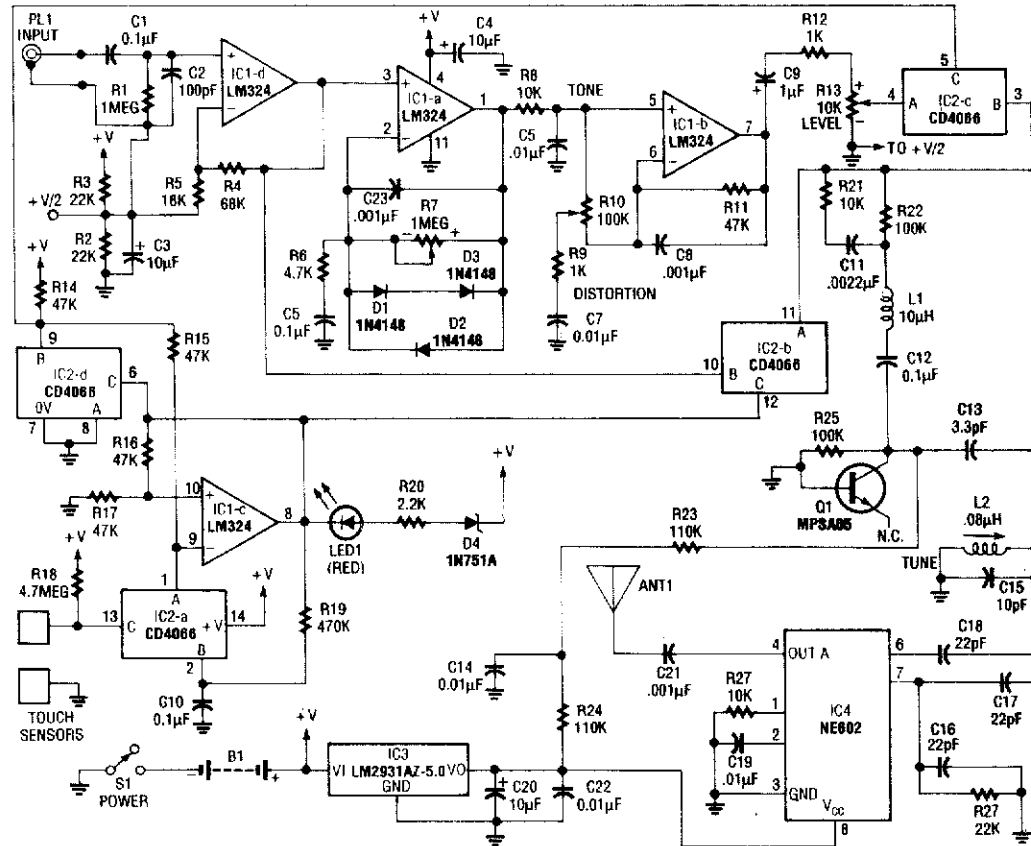

ELECTRONICS NOW

Fig. 96-1

This transmitter has a built-in distortion effects unit and a touch switch to switch effects off and on. The circuit operates from a 9-V battery. IC1-a and IC1-b are used in the effects circuitry. IC1-d is an input preamp and IC2 is a quad analog switch to handle audio switching. Q1 acts as a varactor, diode modulator while IC-4 is an 88- to 108-MHz FM oscillator.

MICRO TV TRANSMITTER

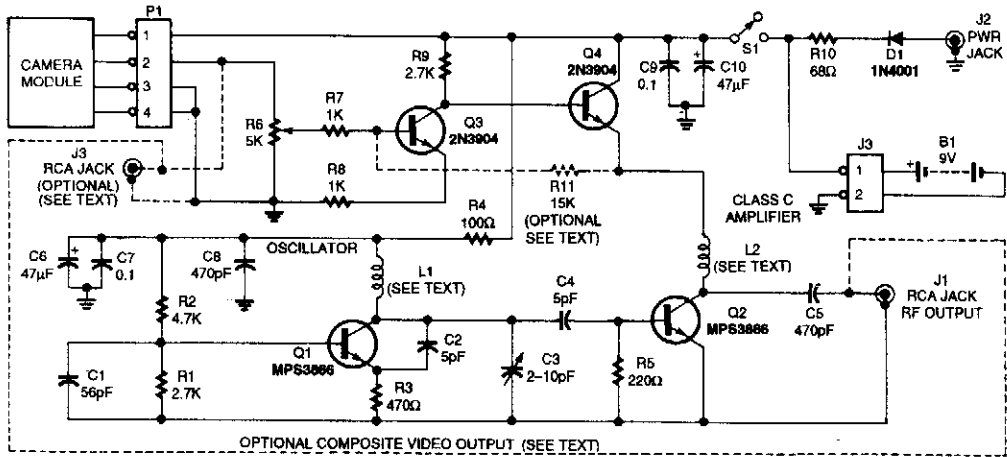

ELECTRONICS NOW

Fig. 96-2

For very low power, noncritical applications, this small TV modulator can be useful as a short-range (50 feet) transmitter for video signals. A small camera module can be used as a source. R11 is used to vary dc offset of the modulator.

WIRELESS MICROPHONE

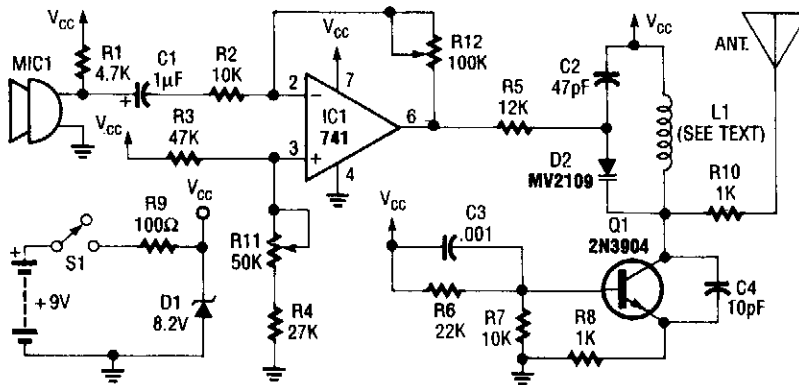

ELECTRONICS EXPERIMENTERS HANDBOOK

Fig. 96-3

An op-amp IC (741) amplifies the audio signal from MIC1, and R12 controls its gain. Audio is fed to the oscillator circuit Q1 and related components. D2 is a varactor diode. Audio fed to D2 causes FM of the oscillator signal. L1 is 2½ turns of #18 wire on a 3/16" diameter form. The antenna is a 12" whip.

FM STEREO TRANSMITTER

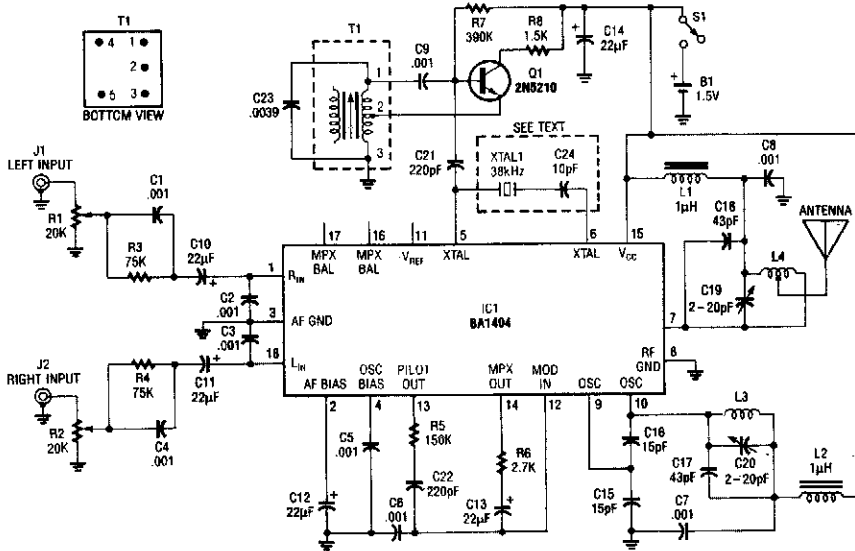

THE HEART OF THE FM TRANSMITTER is a BA1404 FM stereo transmitter IC. The left input-signal level is adjusted via R1, pre-emphasis is provided by C1 and R3, and audio is coupled by C10 into the left-channel input. The right-channel input circuitry is identical.

ELECTRONICS NOW

Fig. 96-4

An FM stereo transmitter can be built around the BA1404 IC. This IC has all the functions necessary to generate an FM MPX signal. A separator oscillator circuit uses a 2N5210 transistor instead of the difficult-to-find 38-kHz crystal that is normally used. T1 is a 455-kHz IF transformer with 0.0039- μ F capacitance added across it to enable tuning to 38 kHz. With this circuit, oscillator stability should be adequate.

FM BUG

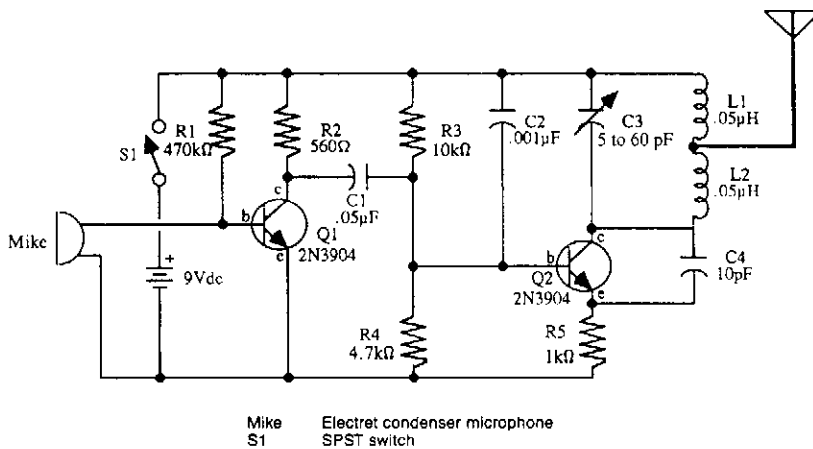

Mike Electret condenser microphone
S1 SPST switch

McGRAW-HILL

Fig. 96-5

LOW-POWER VHF BEACON TRANSMITTER

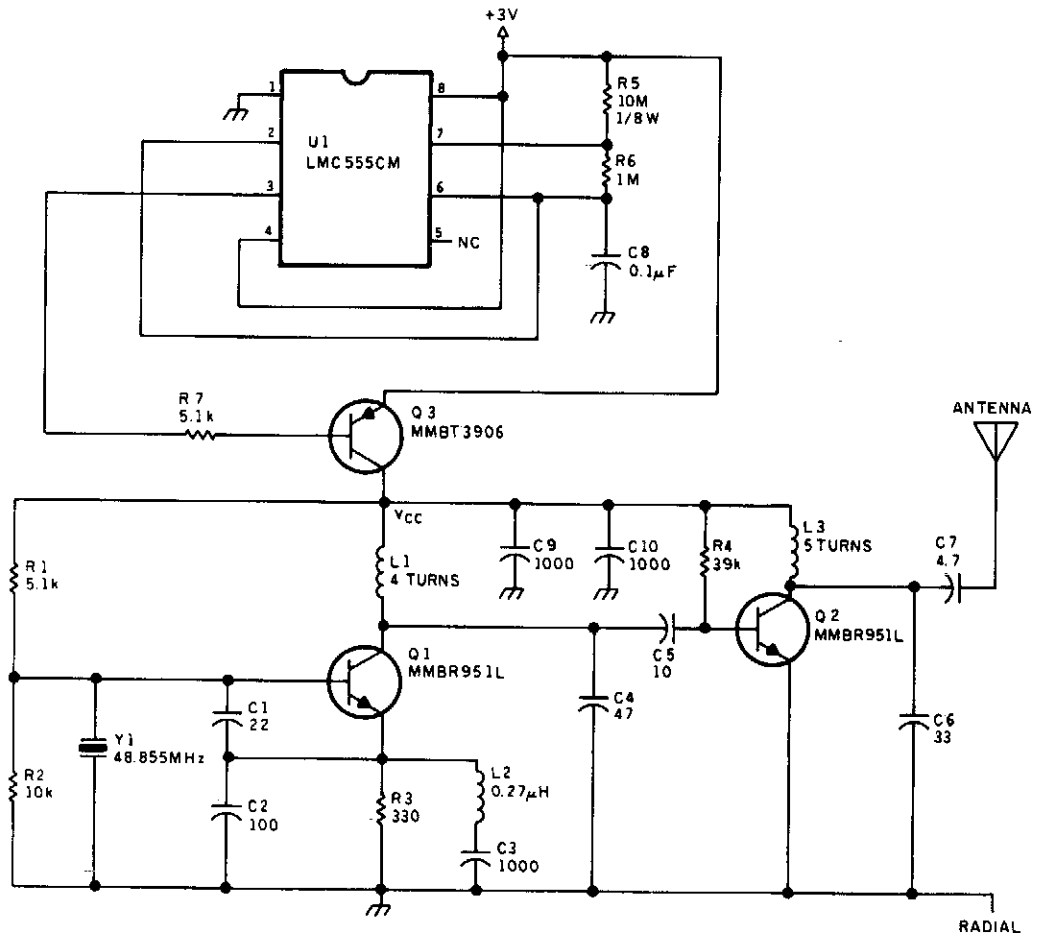

A crystal oscillator and tripler make up the low power beacon transmitter. U1 generates a pulse that keys the transmitter at a 10:1 duty cycle (100 ms on, 1 s off) to conserve battery power. This transmitter was used as a locator beacon.

LOW-COST 6-W, 40-M CW TRANSMITTER

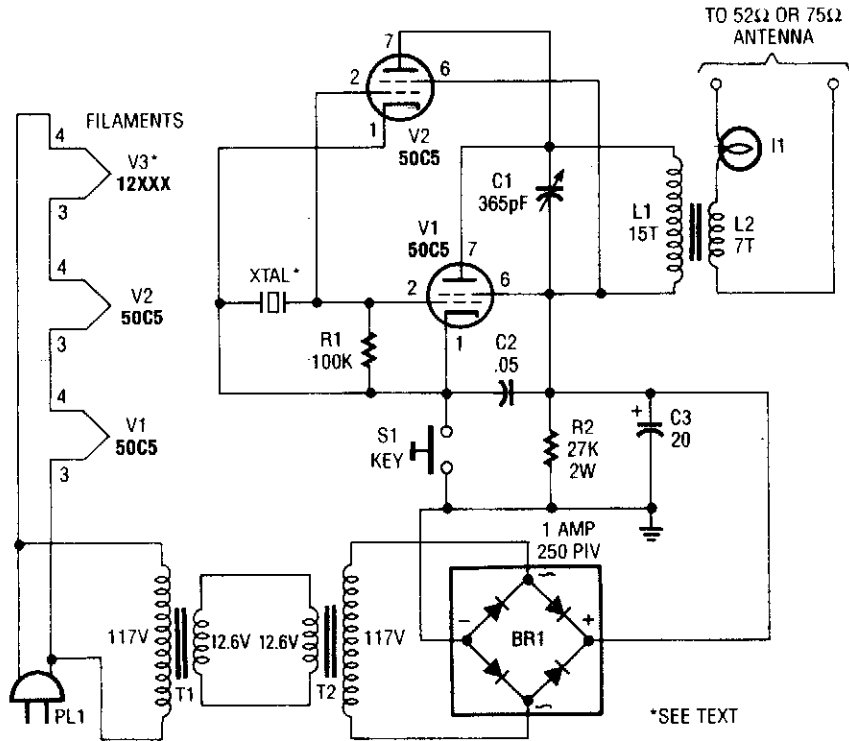

POPULAR ELECTRONICS

Fig. 96-7

L1 and L2 are wound on a $\frac{3}{8}$ " diameter form. L1 is 15 turns #22 plastic-covered wire, and L2 is 7 turns #22 plastic-covered wire.

97

Ultrasonic Circuits

The sources of the following circuits are contained in the Sources section, which begins on page 707. The figure number in the box of each circuit correlates to the entry in the Sources section.

Ultrasonic Remote-Control Tester
Ultrasonic Motion Detector
Ultrasonic CW Transceiver
Ultrasonic Proximity Sensor
Simple Ultrasonic Generator
Ultrasonic Sound Receiver

ULTRASONIC REMOTE-CONTROL TESTER

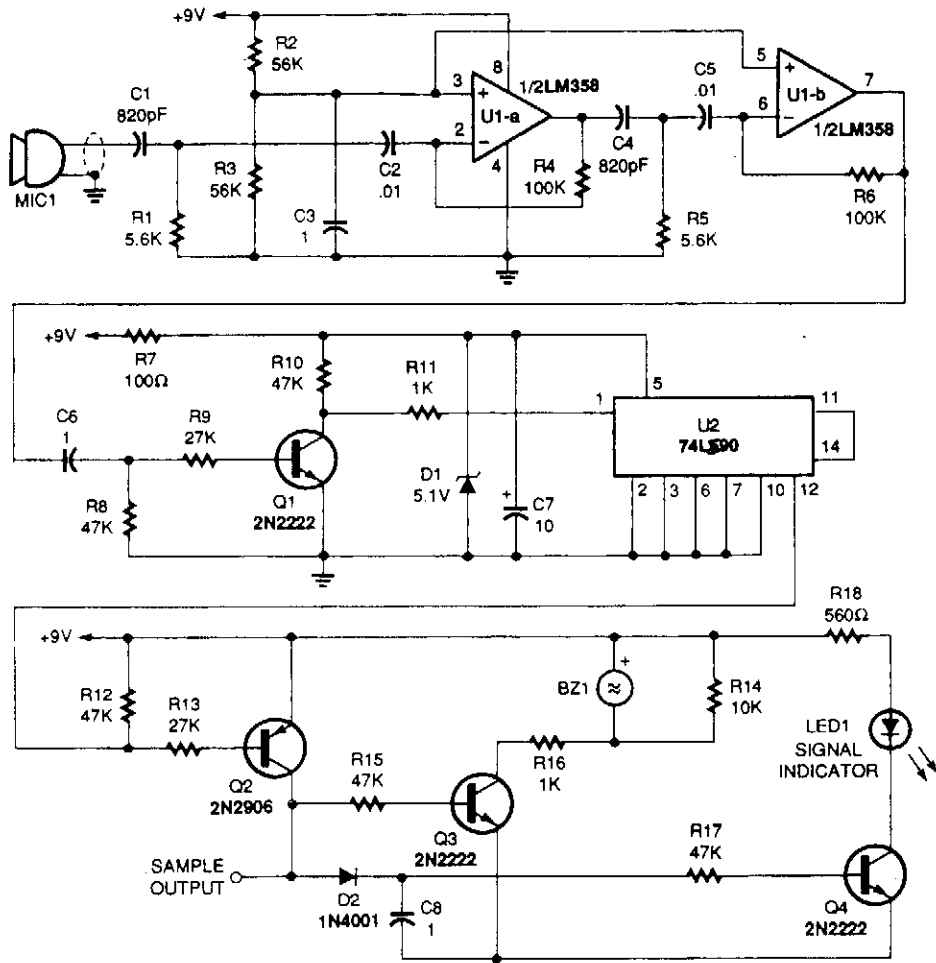

POPULAR ELECTRONICS

Fig. 97-1

This circuit picks up the ultrasonic tone via MIC1, amplifies it, and divides it by 10 in IC U2, a 74LS90. The output of U2 drives an audio amplifier and a piezoelectric element is used as a speaker.

ULTRASONIC MOTION DETECTOR

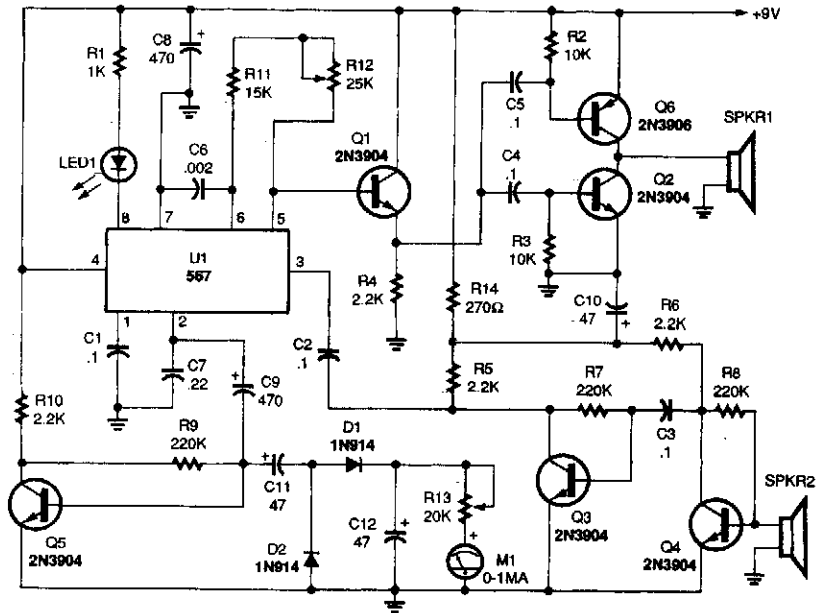

POPULAR ELECTRONICS

Fig. 97-2

A 567 PLL IC operates in a dual-function mode as a signal generator and an FM receiver. The 567's square-wave output at pin 5 is coupled to the base of Q1, and from Q1's emitter to the input of the power amplifier (Q2 and Q6). The output drives the piezo speaker, SPKR1.

The receive portion of the circuit operates as follows: transistors Q3 and Q4 are connected in a two-stage, high-gain, audio-frequency amplifier circuit, with the input connected to a second piezo speaker (SPKR2) operating as a sensitive microphone. The amplifier's output is coupled to the 567's input at pin 3. When an in-band signal is received, the LED lights.

The 567's FM output is coupled from pin 2 to the input of a very-low-frequency single-transistor amplifier, Q5. The amplifier's output at Q5's collector drives a voltage-doubler circuit (C11, D1, D2, and C12). The dc output feeds a 0- to 1-mA analog meter.

By placing the two piezo speakers one foot apart and aiming them in the same direction, toward a nonmoving solid object, the signal from the transmitter's speaker will reflect back into the receiver's speaker, and the frequency at the 567's input will be the same as the one being transmitted.

The ac output at pin 2 is zero when the outgoing and incoming frequencies are the same. However, when the signal is reflected from a moving object, the received frequency will be either lower or higher than the transmitted one. If the object is moving away from the speakers, the received frequency will be lower; if the object is moving toward the speakers, the frequency will be higher.

The pin-2 signal is fed through a 470- μ F capacitor to the base of Q5, where the signal is amplified and fed to a voltage doubler, and then on to a meter circuit.

If you wish, the voltage doubler and meter can be removed and replaced with headphones connected between the negative side of C11 and circuit ground. That will allow you to listen to the difference-frequency signal as objects move in front of the speakers.

ULTRASONIC CW TRANSCEIVER

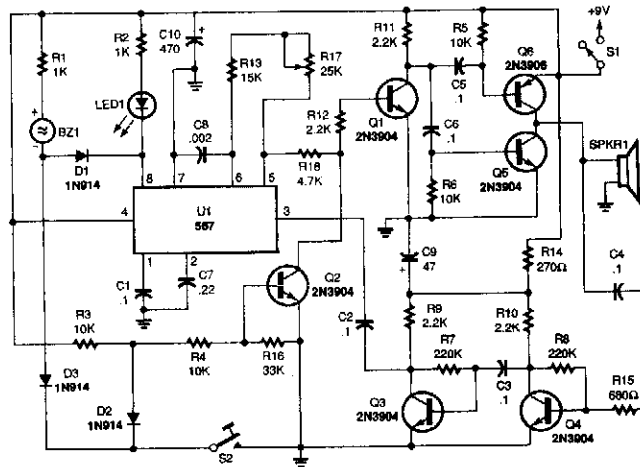

Fig. 97-3

POPULAR ELECTRONICS

With the telegraph key at S2 "up" (open), the 567 PLL's input at pin 3 is coupled to the output of Q3. Transistors Q3 and Q4 are operating in a high-gain, two-stage audio-amplifier circuit. The piezo speaker is coupled to the input of the amplifier through a 0.1- μ F capacitor and a 680- Ω isolation resistor.

In the receive mode, the piezo speaker operates as a sensitive microphone. Ultrasonic signals travel from the microphone through the two-stage amplifier to the input of the 567, and, if the signal's frequency is within the IC's bandwidth, the LED will light and piezo-sounder BZ1 will sing out for

each "dit" and "dah" received. The receiver can be tuned to the incoming ultrasonic signal by adjusting R17. Of course, adjusting that potentiometer also changes the transmitter's frequency.

The transmitter operates each time the S2 is closed. When the key is closed, diode D3 supplies a path to ground for BZ1, causing that sounder to produce an audible signal for each "dit" and "dah" transmitted. Also, Q2's bias is taken to ground through D2, allowing Q1 to pass the 567's square-wave signal on to the input of the power amplifier and out through the speaker.

ULTRASONIC PROXIMITY SENSOR

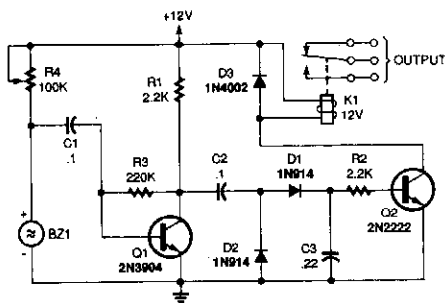

Fig. 97-4

POPULAR ELECTRONICS

A 100-k Ω potentiometer, R4, sets the current fed to the Sonalert sounder. The potentiometer is adjusted to a point where the sounder

just begins to make an audible sound. A single-transistor audio amplifier (Q1) is coupled to the positive side of the sounder and its output is fed to a voltage-doubler circuit. The doubler's dc output drives the base of Q2, which, in turn, operates the relay (K1). As long as the Sonalert is producing a sound, the relay stays energized.

When a solid object is moved in close proximity to the front of the sounder, the Q of the piezo element is lowered and the Sonalert's internal circuit ceases to operate; as a result, the relay drops out. By carefully adjusting R4, the circuit can be made quite sensitive.

SIMPLE ULTRASONIC GENERATOR

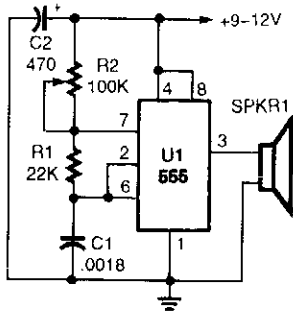

This basic ultrasonic generator can be built easily and quickly. An NE555 drives a speaker. The frequency range is 12 to 50 kHz. SPKR1 is a piezo tweeter, etc.

POPULAR ELECTRONICS

Fig. 97-5

ULTRASONIC SOUND RECEIVER

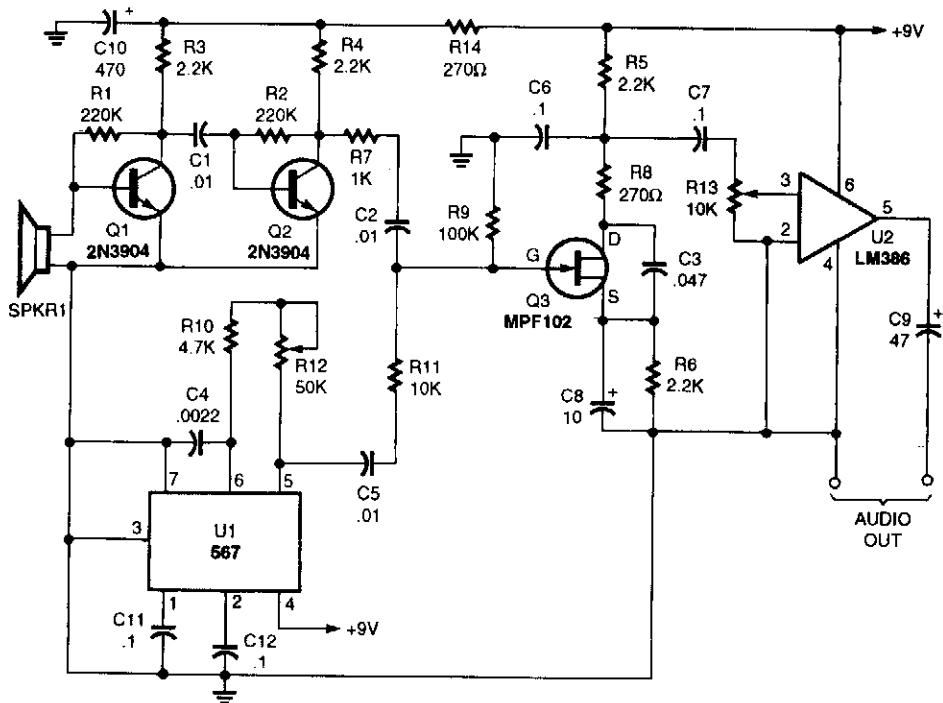

POPULAR ELECTRONICS

Fig. 97-6

You won't be disappointed with the performance of this sensitive ultrasonic receiver. It can let you listen to bugs, bats, engines, and virtually any other source of ultrasonic sounds. This circuit uses a piezo tweeter as an ultrasonic microphone, amplifier stages Q1, Q2, and an LO using a 567 IC. Q3 is a mixer that heterodynes the ultrasonic sounds down to the audible range. U2 is an amplifier that will drive a pair of headphones.

98

Video Circuits

The sources of the following circuits are contained in the Sources section, which begins on page 707. The figure number in the box of each circuit correlates to the entry in the Sources section.

Video Titler
Video Amplifier
RGB Video Amplifier
One-of-Two Video Selector
NTSC-to-RGB Converter
Video IF Amplifier/Detector
Video Cable Driver
Simple NTSC Gray-Scale Video Generator
LM1201 Video Amplifier
Simple Video Gray-Scale Generator European Line Standard
Video Switch
Adjustable Video-Cable Equalizer
Video Summing Amplifier
Video Amplifier
Twisted-Pair Video Driver/Receiver Circuit
250-mA 60-MHz Current-Feedback Amplifier for Video Applications
Video Driver/Amplifier
Video Line Driver

VIDEO TITLER

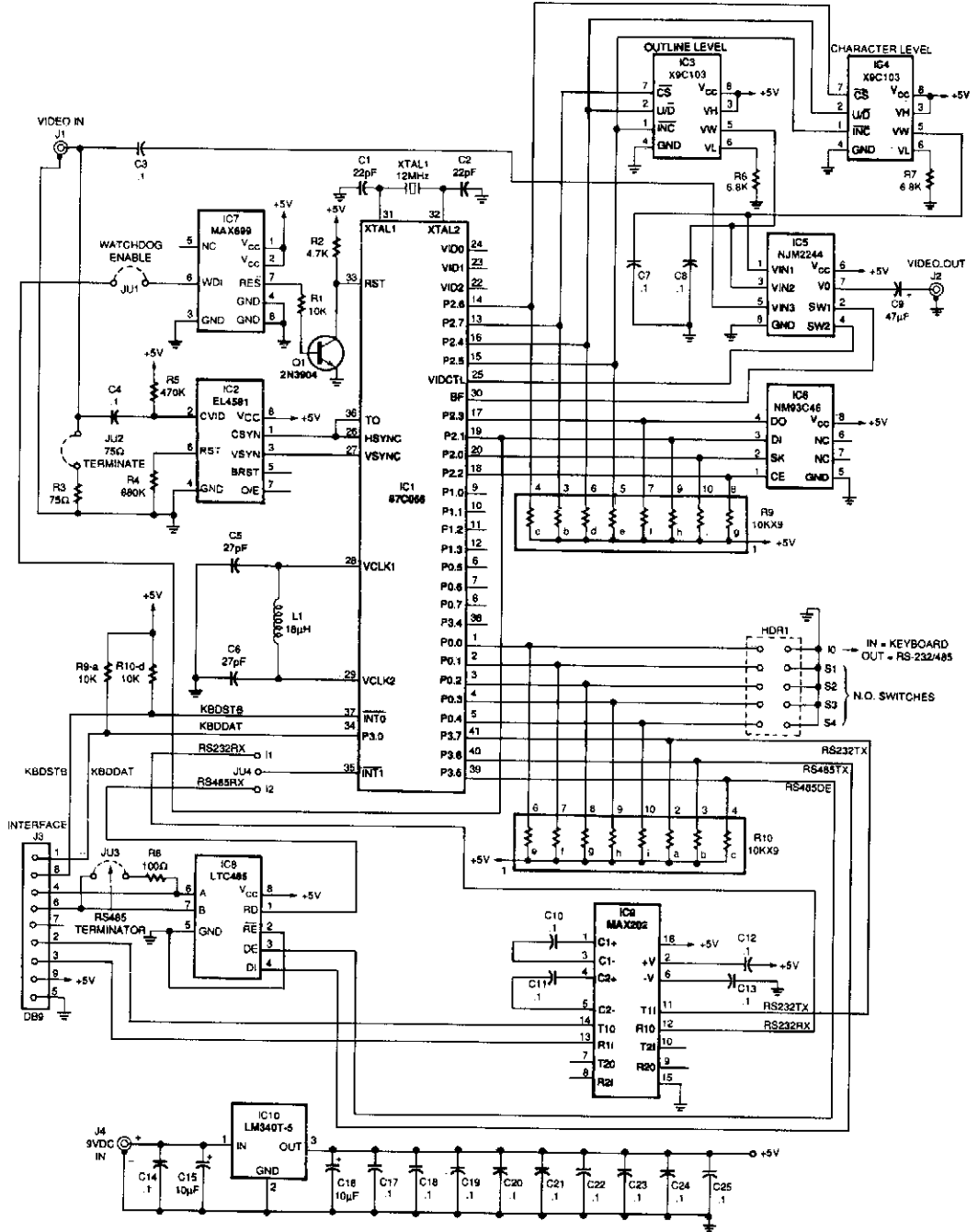

VIDEO TITLER (Cont.)

IBM PC/AT RS232 SERIAL CABLE



a

IBM PC/AT KEYBOARD CABLE

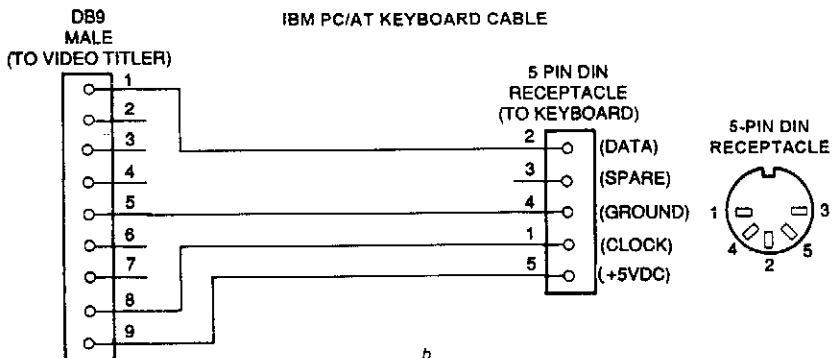

b

RS485 CABLE

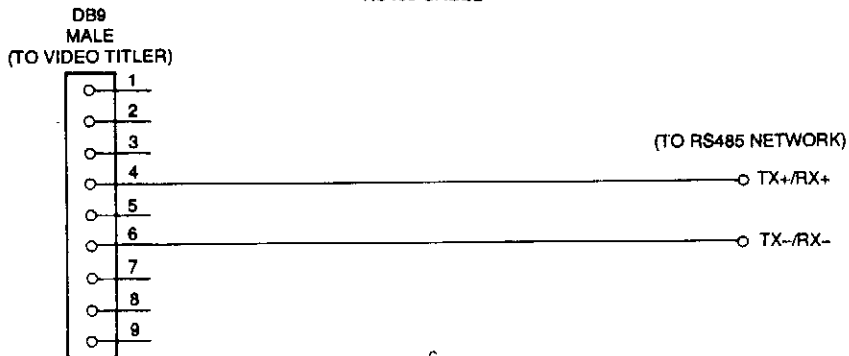

c

There is a different cable for each interface. The RS-232 serial cable is shown in a, the PC/AT keyboard cable is shown in b, and the RS-485 cable is shown in c.

VIDEO TITLER (Cont.)

The figure shows the schematic of the video titler circuit. The power-on reset function is generated by IC7, a Maxim MAX699 reset, and watchdog pulse generator. That device supplies a reset pulse of 140 to 500 ms at power-up. This is accomplished with some external parts, as well as the OSD controller in IC1. First, the horizontal and vertical sync from the composite video input is detected by IC2, which is set for NTSC specification horizontal and vertical synchronization timing via resistor R4.

The detected horizontal and vertical sync is fed to IC1. The OSC controller in IC1 uses these signals to internally synchronize the overlay text to the incoming video. The frequency of the dot clock is controlled by components L1, C5, and C6. Text is overlaid by video multiplexer IC5, which is controlled by IC1.

The overlay character outline and intensity are controlled via solid-state potentiometers, allowing the microcontroller to control the position of their wipers and store the settings in an onboard EEPROM. The microcontroller's OSC logic controls the multiplexer timing from the BF (IC1, pin 30) and VIDCTL (IC1, pin 25) signals. The BF signal switches the video multiplexer between character and character-outline video, and VIDCTL switches the multiplexer between the input video and the overlay video from IC1. The dc levels from IC3 and IC4 set the character and outline intensity, and these levels are fed to video multiplexer IC5.

The video titler can store and recall text from EEPROM IC6, which has enough capacity to store one overlay screen and other required data, such as network address, horizontal and vertical overlay fine position, and type of interface.

The RS-232 interface is provided by a MAX202 transceiver. The RS-485 interface is provided by an LTC485 transceiver that provides both transmit and receive functions. The keyboard interface is basically a direct connection to the microprocessor.

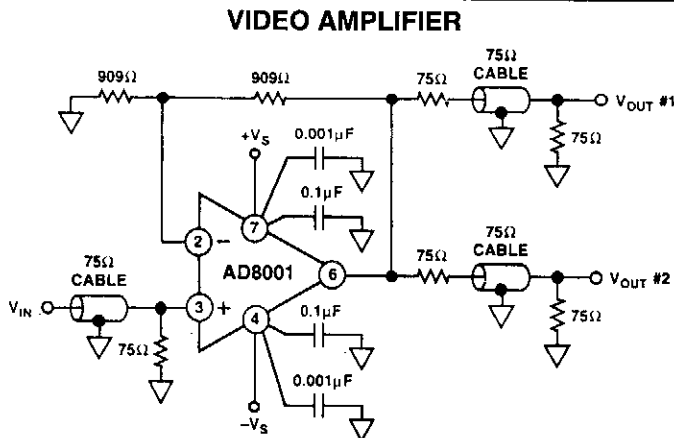

ANALOG DEVICES

Fig. 98-2

The AD8001 has been designed to offer outstanding performance as a video line driver. The important specification of differential gain (0.01%) and differential phase (0.025°) meet the most exacting HDTV demands for driving one video load. The AD8001 also drives up to two back-terminated loads with equally impressive performance (0.01%, 0.07°). Another important consideration is isolation between loads in a multiple-load application. The AD8001 has more than 40 dB of isolation at 5 MHz when driving two 75-Ω terminated loads.

RGB VIDEO AMPLIFIER

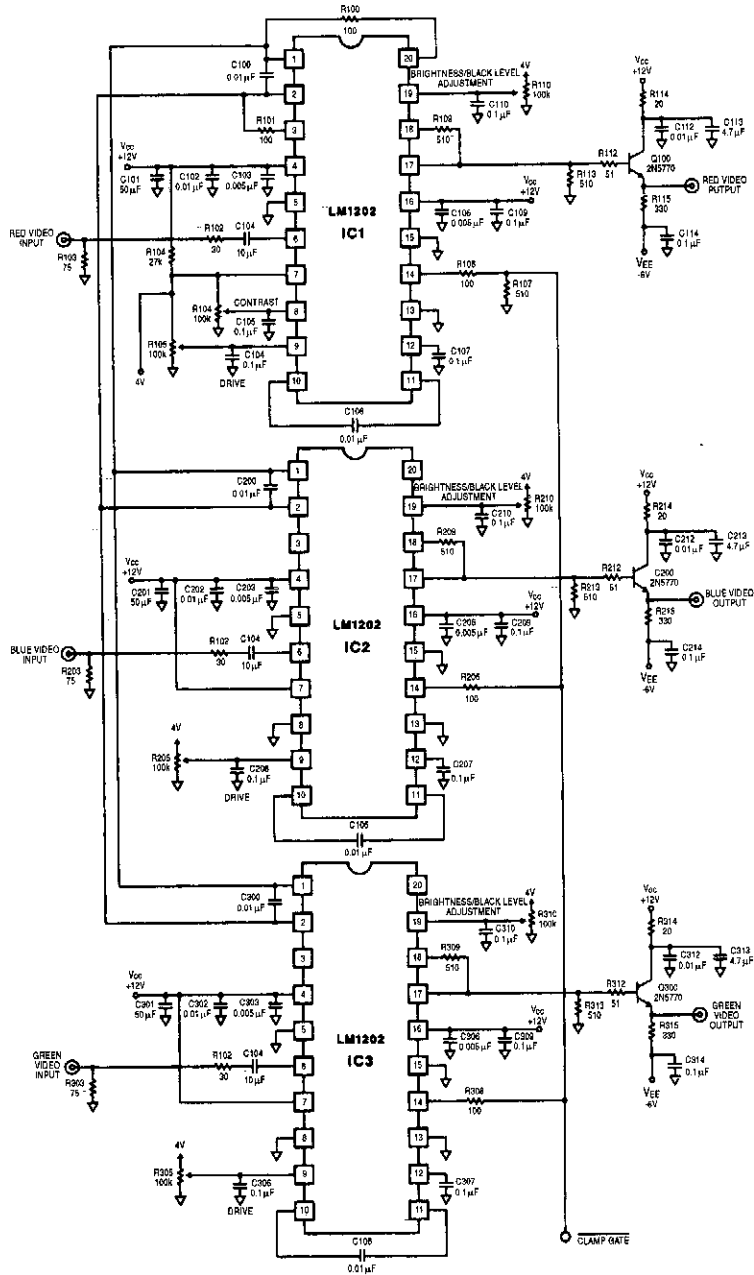

NATIONAL SEMICONDUCTOR

Fig. 98-3

This circuit is a three-channel RGB video amplifier with individual brightness, black level and drive controls.

ONE-OF-TWO VIDEO SELECTOR

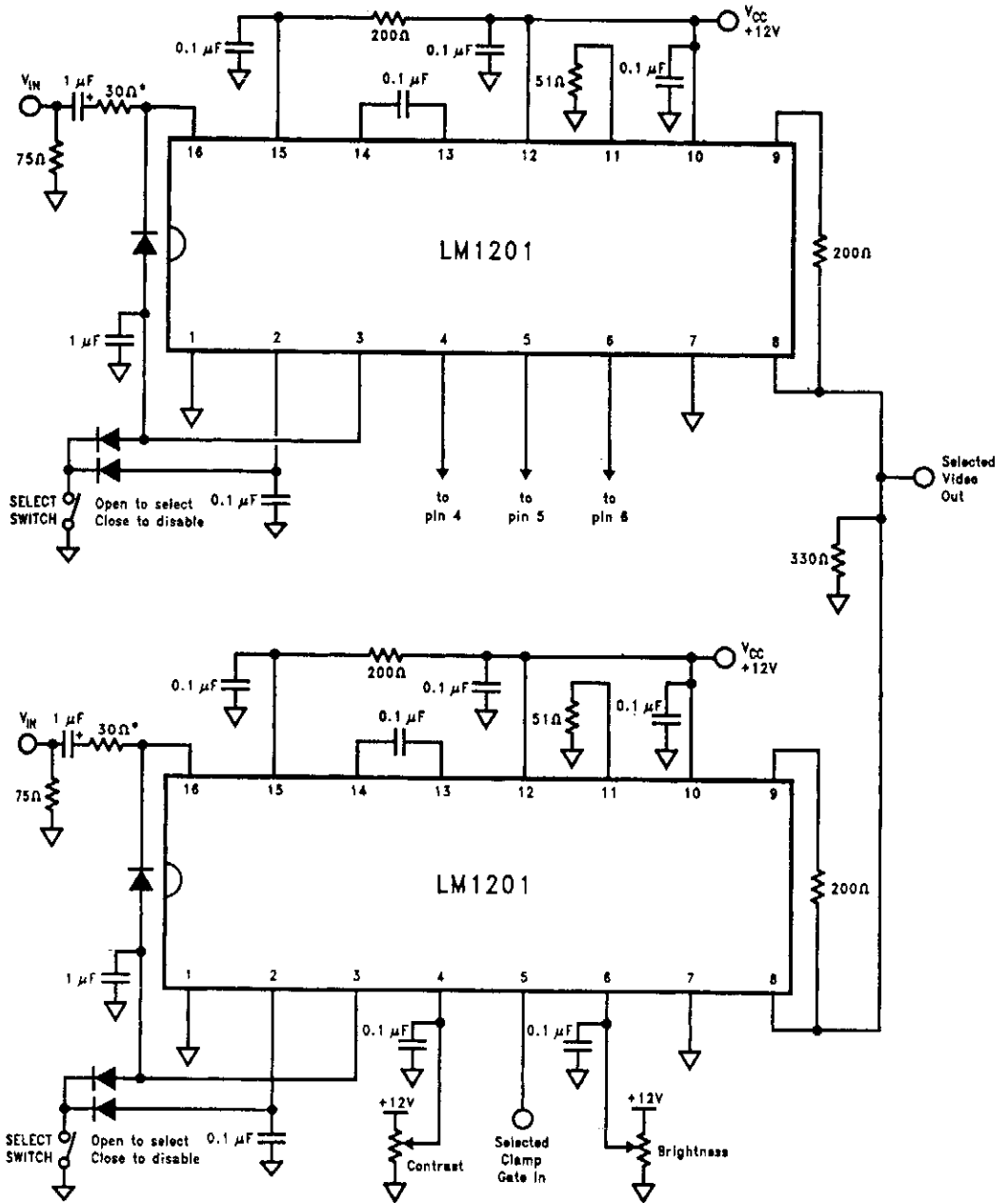

NTSC-TO-RGB CONVERTER

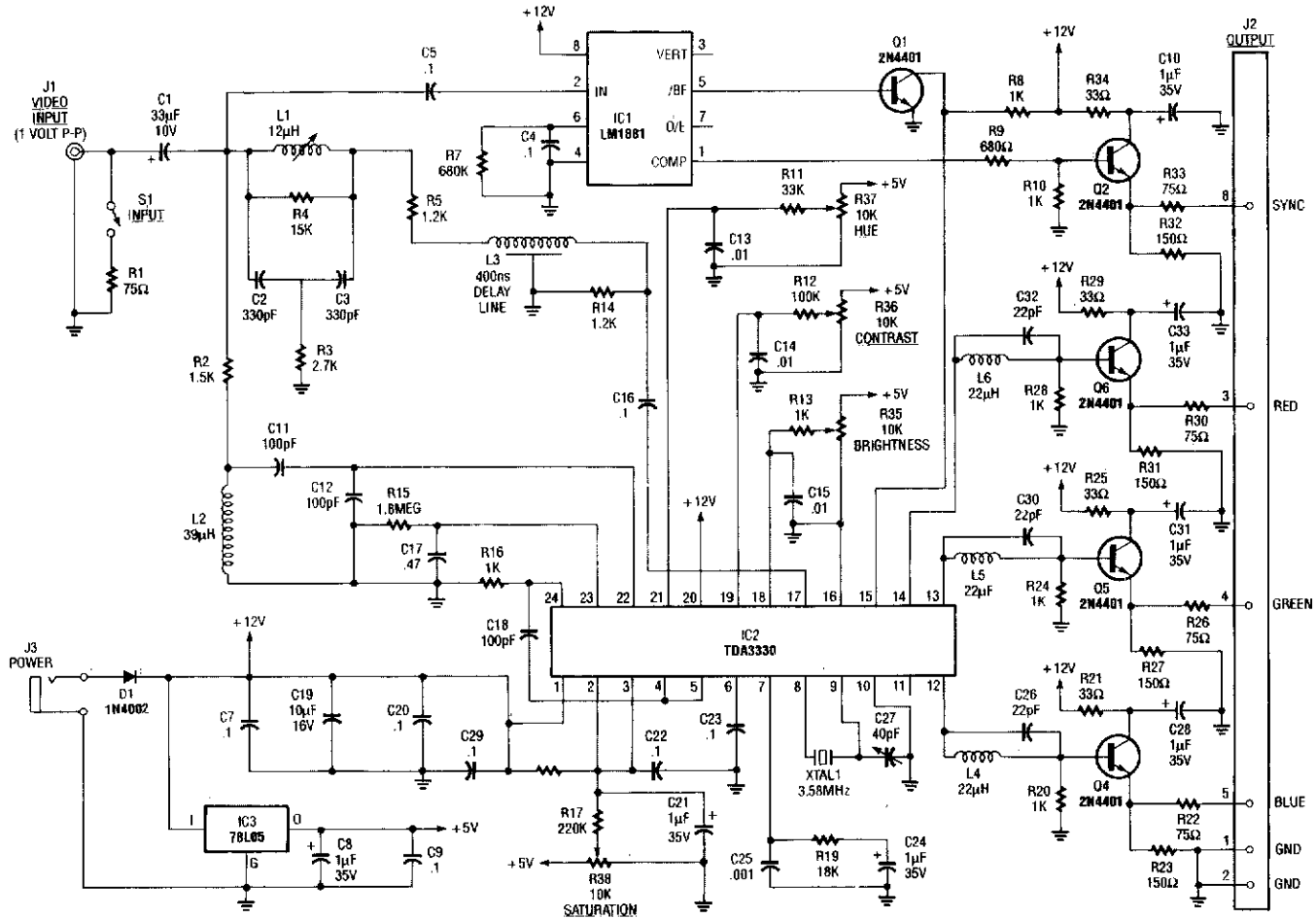

RADIO-ELECTRONICS

Fig. 98-5

This circuit takes baseband NTSC video, decodes it, and derives RGB video suitable for driving a color multisync computer monitor. This enables the user to take advantage of the generally better resolution of computer monitors.

VIDEO IF AMPLIFIER/DETECTOR

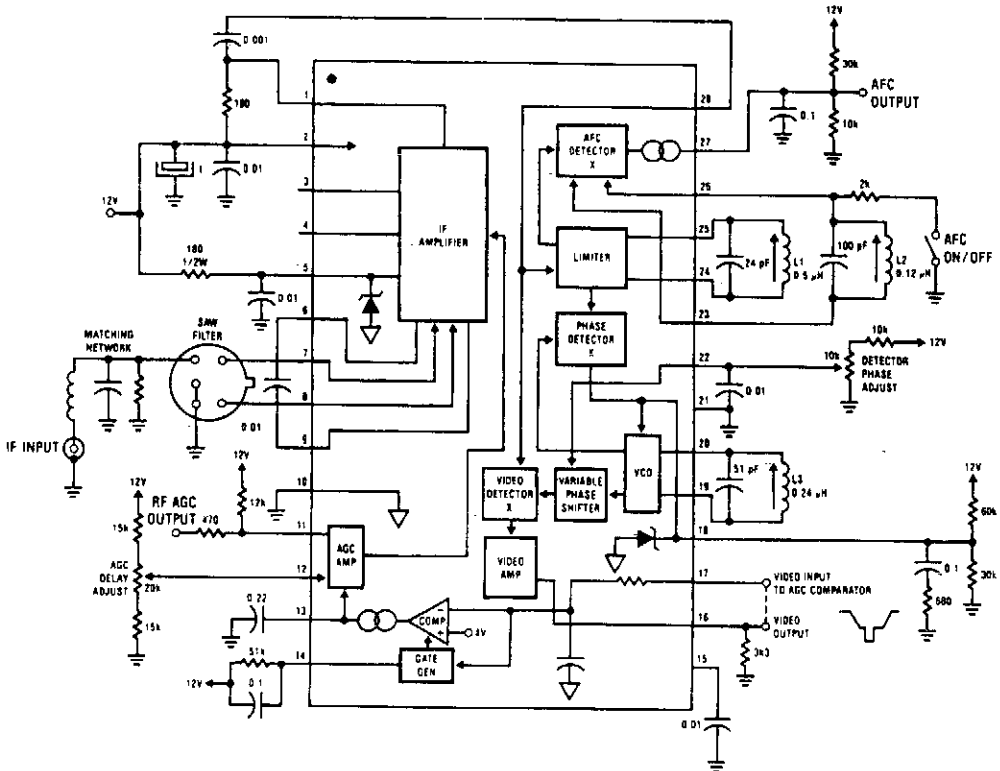

SAW Filter-MuRata SAF45MC/MA

- L1-9 1/2T } # 22 wire
 - L2-4 1/2T } on 3.16" form with
 - L3-6 1/2T } HF core, shielded
- All caps in uF unless noted

NATIONAL SEMICONDUCTOR

Fig. 98-6

VIDEO CABLE DRIVER

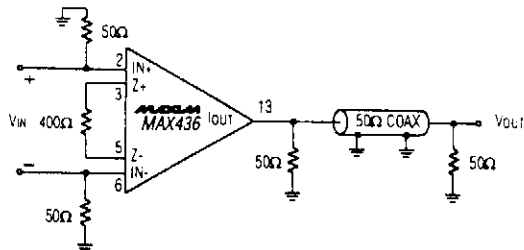

MAXIM

Fig. 98-7

This is a MAX436 coaxial-cable driving circuit.

SIMPLE NTSC GRAY-SCALE VIDEO GENERATOR

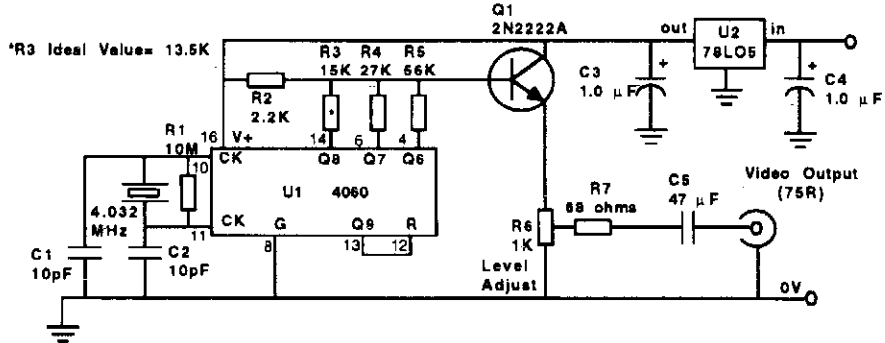

73 AMATEUR RADIO TODAY

Fig. 98-8

A 4.032-MHz crystal oscillator (256 × horizontal line scan rate) drives a BCD counter. The binary outputs of the counter are fed to R2 through R5, a simple weighting network for D/A conversion, resulting in a staircase video output with a rep rate of 15.75 kHz. This circuit should be useful for amateur TV linearity testing and setup purposes.

LM1201 VIDEO AMPLIFIER

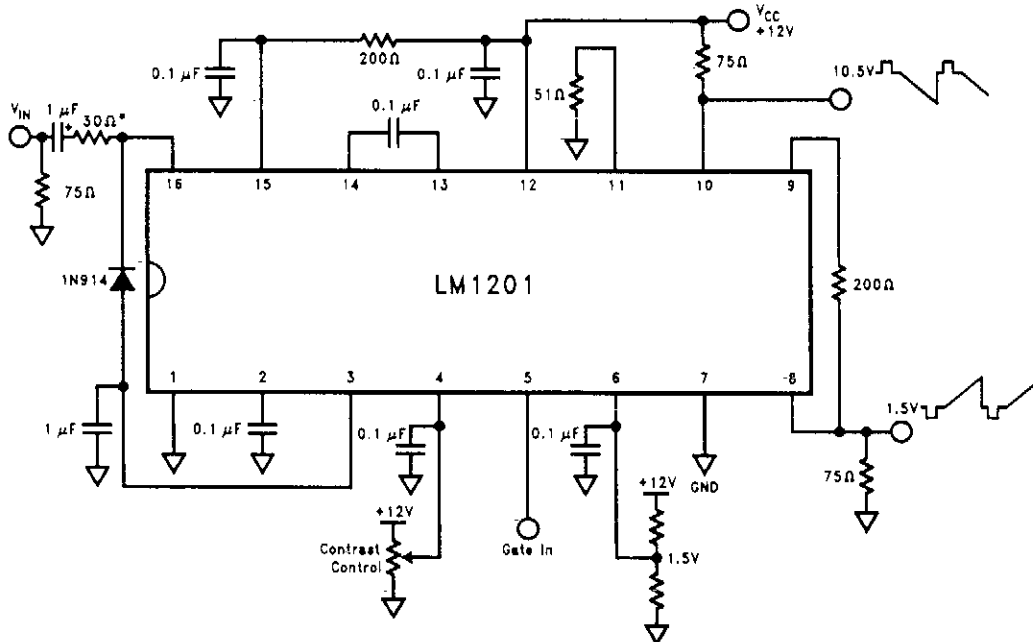

NATIONAL SEMICONDUCTOR

Fig. 98-9

This video amplifier has 75-Ω bi-phase outputs.

SIMPLE VIDEO GRAY-SCALE GENERATOR EUROPEAN LINE STANDARD

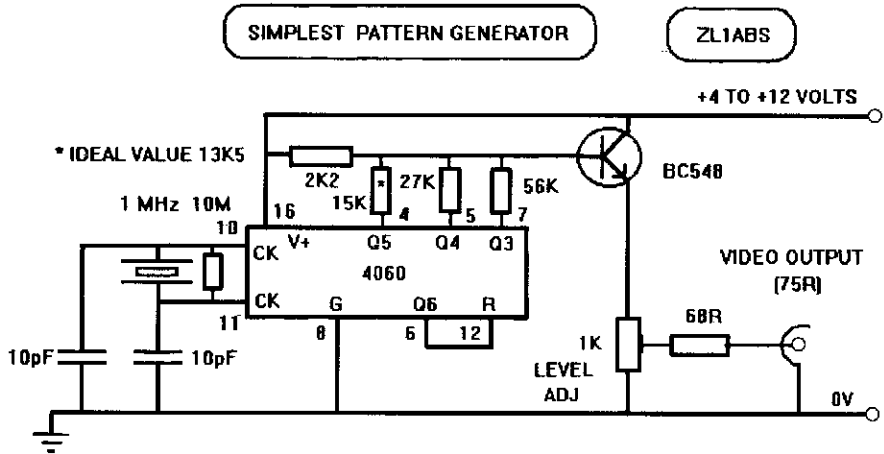

73 AMATEUR RADIO TODAY

Fig. 98-10

A simple gray-scale generator (staircase waveform) can be obtained with a CD4060 counter, a 1-MHz crystal oscillator, and several resistors to act as an elementary D/A converter to convert the binary count output to analog equivalent. This circuit is for European (PAL) standards.

VIDEO SWITCH

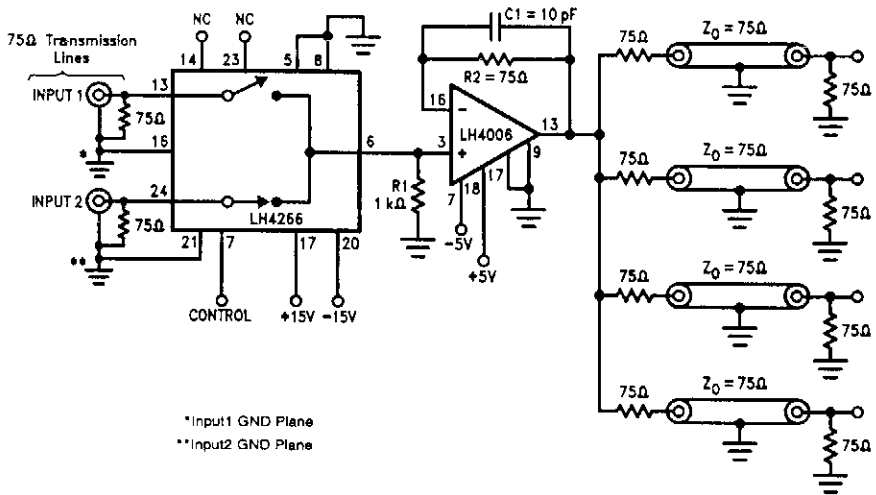

NATIONAL SEMICONDUCTOR

Fig. 98-11

Using National Semiconductor LH4266 and LH4006, this circuit switches one of two inputs to four output (75 Ω) lines.

ADJUSTABLE VIDEO-CABLE EQUALIZER

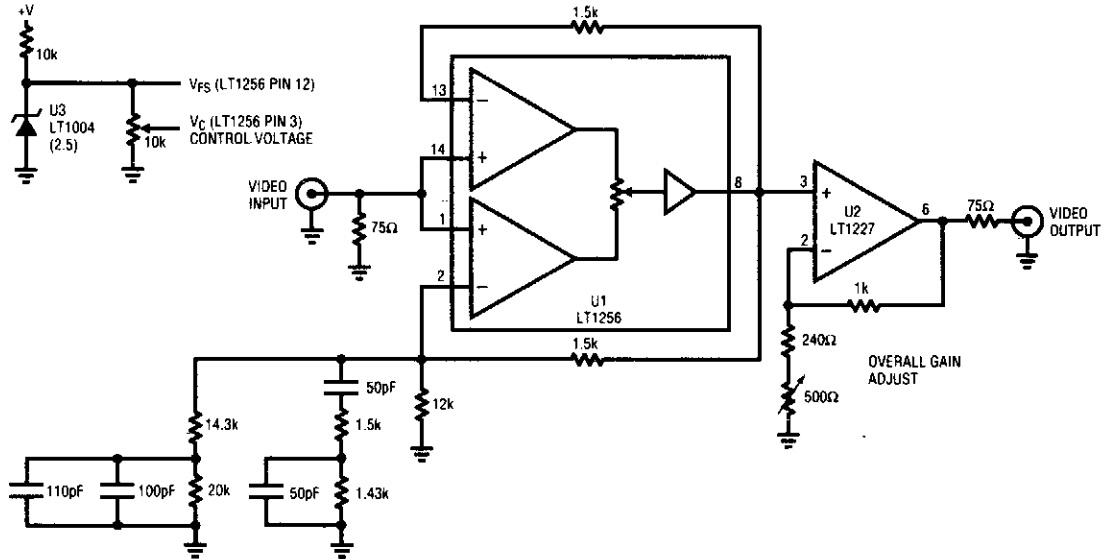

LINEAR TECHNOLOGY

Fig. 98-12

The figure is a complete schematic of the cable equalizer. The LT1256 (U1) is a two-input/one-output 40-MHz current feedback amplifier with a linear control circuit that sets the amount that each input contributes to the output. One amplifier (input pins 13 and 14) of the LT1256 is configured as a gain of one with no frequency equalization. The other amplifier (input pins 1 and 2) has frequency equalizing components in parallel with the 12-kΩ gain resistor. An additional amplifier (U2, LT1227) is used to set the overall gain. Two amplifiers were used here to make setting the gain a single adjustment, but in a production circuit, the LT1256 can be configured to have the necessary gain and the whole function can be done with one chip.

VIDEO SUMMING AMPLIFIER

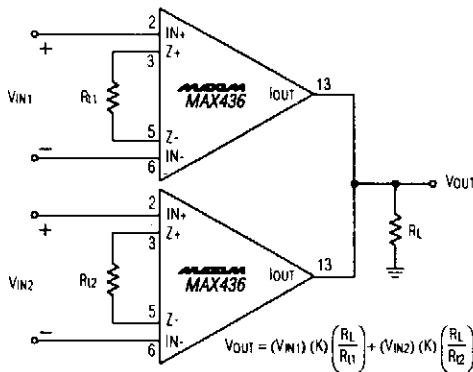

MAXIM

Fig. 98-13

VIDEO AMPLIFIER

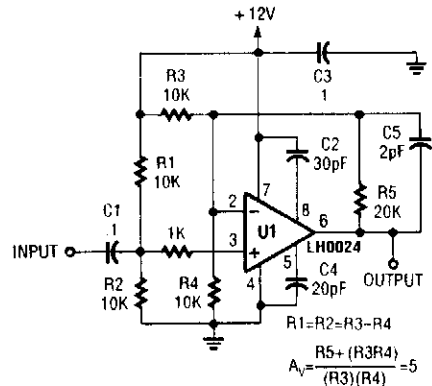

POPULAR ELECTRONICS

Fig. 98-14

TWISTED-PAIR VIDEO DRIVER/RECEIVER CIRCUIT

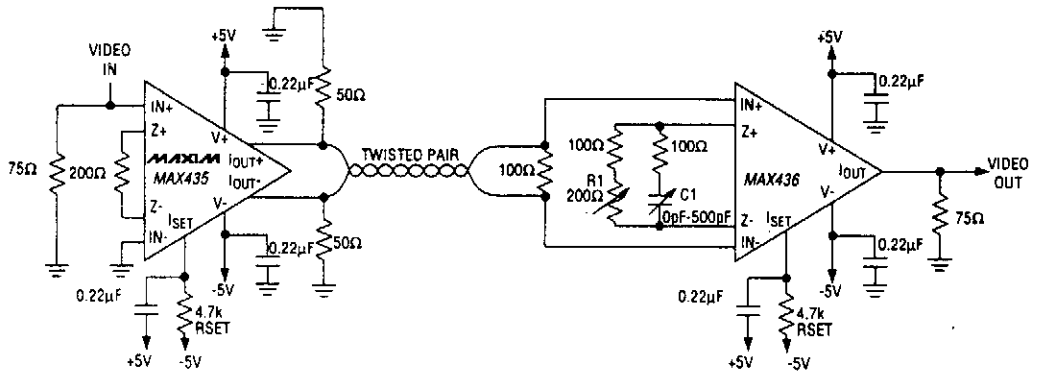

MAXIM

Fig. 98-15

This circuit should be useful where a twisted-pair video line is to be used. R1 is adjusted for proper gain (monitor brightness and contrast) and C1 is adjusted for best color.

250-mA 60-MHz CURRENT-FEEDBACK AMPLIFIER FOR VIDEO APPLICATIONS

Noninverting Amplifier with Shutdown

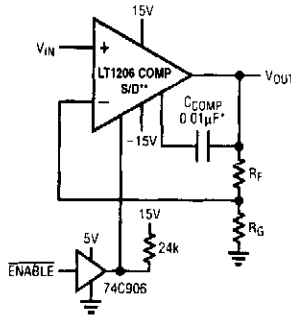

*OPTIONAL USE WITH CAPACITIVE LOADS
 *GROUND SHUTDOWN P/IN FOR NORMAL OPERATION

Large-Signal Response, $C_L = 10,000\text{pF}$

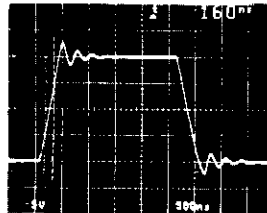

$V_S = \pm 15\text{V}$, $R_L = \infty$, $R_F = R_G = 3\text{k}$

LINEAR TECHNOLOGY

Fig. 98-16

VIDEO DRIVER/AMPLIFIER

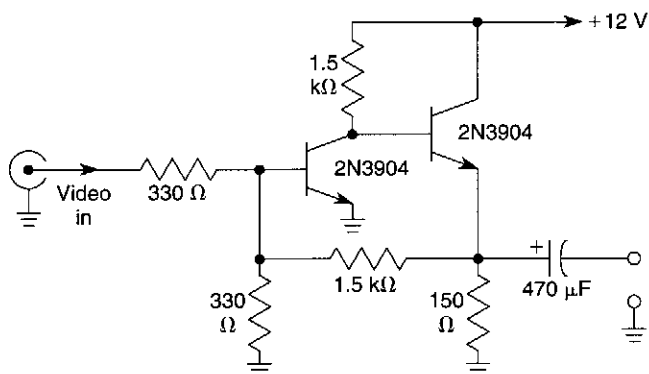

WILLIAM SHEETS

Fig. 98-17

This simple circuit has a voltage gain of about 5× and will drive low-impedance loads (75 Ω) to 1.5 V p-p or better.

VIDEO LINE DRIVER

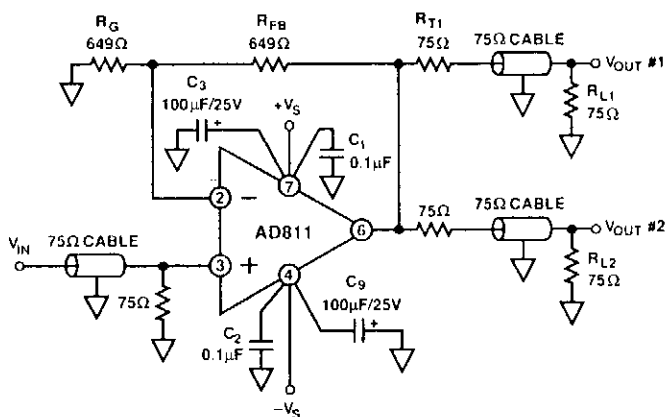

ANALOG DEVICES

Fig. 98-18

This video buffer/line driver operates at a gain of +2 and drives a pair of 75-Ω lines with 75-Ω back terminations. The overall terminated gain is unity.

99

Voltage-Controlled Amplifier Circuits

The sources of the following circuits are contained in the Sources section, which begins on page 707. The figure number in the box of each circuit correlates to the entry in the Sources section.

Voltage-Controlled Amplifier
Voltage-Controlled Audio Amplifier

VOLTAGE-CONTROLLED AMPLIFIER

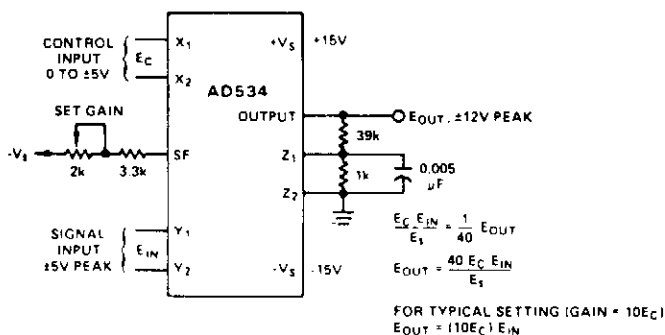

ANALOG DEVICES

Fig. 99-1

A constant or varying signal applied to the X input, E_c , controls the gain for a constant or variable signal applied to the Y input, E_{in} . The inputs could be interchanged.

For this circuit, the "set gain" potentiometer is typically adjusted to provide a calibration for gain of Z 10 per-V-of- E_c . The bandwidth is dc to 30 kHz, independent of the gain. The wideband noise (10 Hz to 30 kHz) is 3 mV rms, typically, corresponding to full-scale signal-to-noise of 70 dB. Noise, referred to the signal input ($E_c = \pm 5$ V) is 60 μ V rms, typically.

VOLTAGE-CONTROLLED AUDIO AMPLIFIER

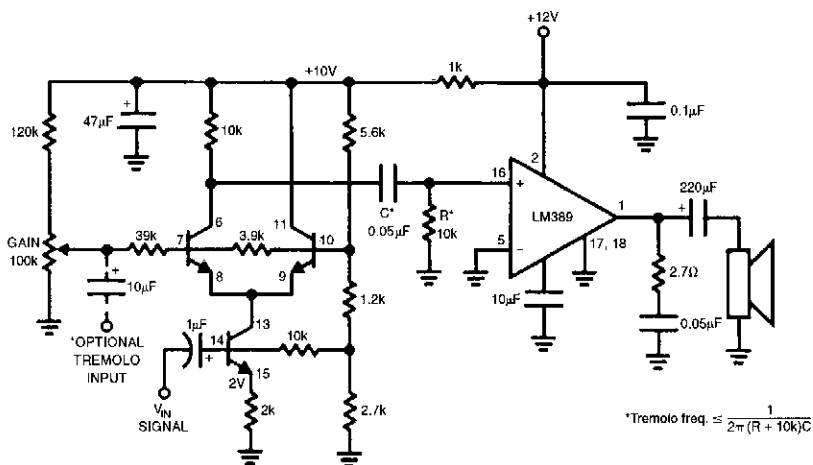

NATIONAL SEMICONDUCTOR

Fig. 99-2

The LM389 has internal transistors used in this circuit.

100

Voltage-Controlled Oscillator Circuits

The sources of the following circuits are contained in the Sources section, which begins on page 707. The figure number in the box of each circuit correlates to the entry in the Sources section.

Three-Decade VCO

Voltage-Controlled Two-Phase Oscillator

THREE-DECADE VCO

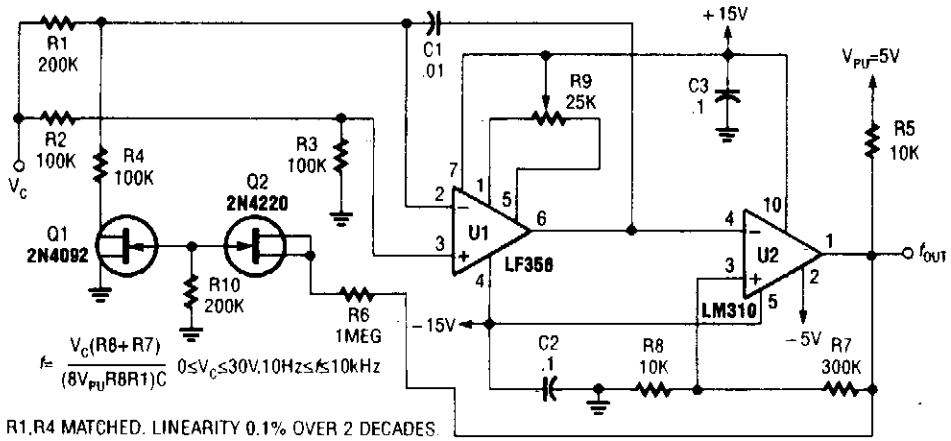

POPULAR ELECTRONICS

Fig. 100-1

A range of 10 Hz to 10 kHz is covered by this circuit.

VOLTAGE-CONTROLLED TWO-PHASE OSCILLATOR

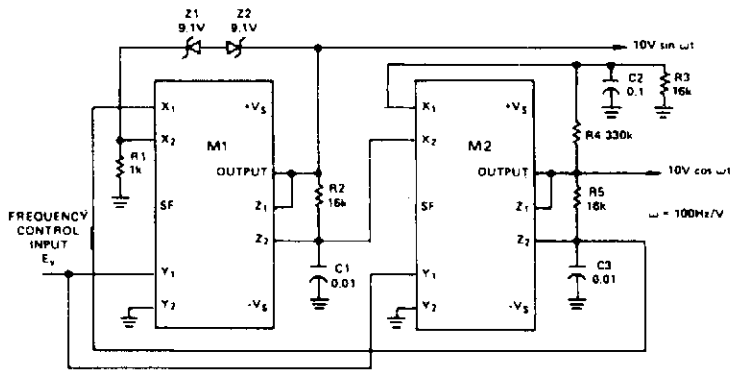

ANALOG DEVICES

Fig. 100-2

This circuit uses two multipliers for integration-with-controllable-time-constants in a feedback loop. R2 and R5 will be recognized in the AD534 voltage-to-current configuration; the currents are integrated in C1 and C3, and the voltages they develop are connected at high impedance in proper polarity to the X inputs of the "next" AD534. The frequency-control input, EY, varies the integrator gains, with a sensitivity of 100 Hz/V, and frequency error typically less than 0.1% of full scale from 0.1 V to 10 V (10 Hz to 1 kHz). C2 (proportional to C1 and C3), R3, R4 provide regenerative damping to start and maintain oscillation. Z₁ and Z₂ stabilize the amplitude at low distortion by degenerative damping above ±10 V.

101

Voltage-Measuring Circuits

The sources of the following circuits are contained in the Sources section, which begins on page 706. The figure number in the box of each circuit correlates to the entry in the Sources section.

Meter Amplifier for 1.5-V Supply
Voltage Monitor
ac Voltmeter Has Unique Features
dc Voltmeter
Expanded-Scale dc Meter for 12-V Systems
Simple 3-Digit DVM
Inexpensive Voltage Calibrator
Double-Ended Voltage Monitor
Audible Voltage Indicator
Low-Drain Meter Amplifier

METER AMPLIFIER FOR 1.5-V SUPPLY

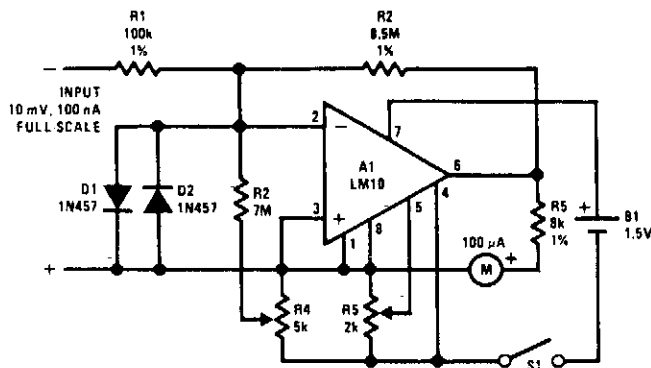

NATIONAL SEMICONDUCTOR

Fig. 101-1

An LM10 is used as a meter amplifier. Accuracy can be maintained over a 15°C to 55°C range for a full-scale sensitivity of 10 mV and 100 nA. The offset voltage error is nulled with R5, and the bias current can be balanced out with R4. The zeroing circuits operate from the reference output and are essentially unaffected by changes in battery voltage, so frequent adjustments should not be necessary. Total current drain is under 0.5 mA, giving an approximate life of 3 to 6 months with an "AA" cell and over a year with a "D" cell. With these lifetimes, an ON/OFF switch might be unnecessary. A test switch that converts to a battery-test mode might be of greater value.

VOLTAGE MONITOR

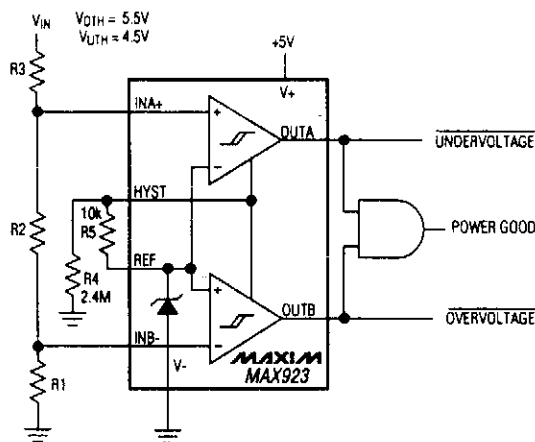

MAXIM

Fig. 101-2

A MAX923 dual comparator is used as a window detector. For a threshold of 4.5 V and 5.5 V, $R_1 = 1.068 \text{ M}\Omega$, $R_2 = 61.9 \text{ k}\Omega$, and $R_3 = 1 \text{ M}\Omega$.

ac VOLTMETER HAS UNIQUE FEATURES

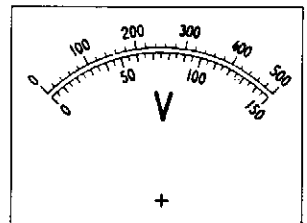
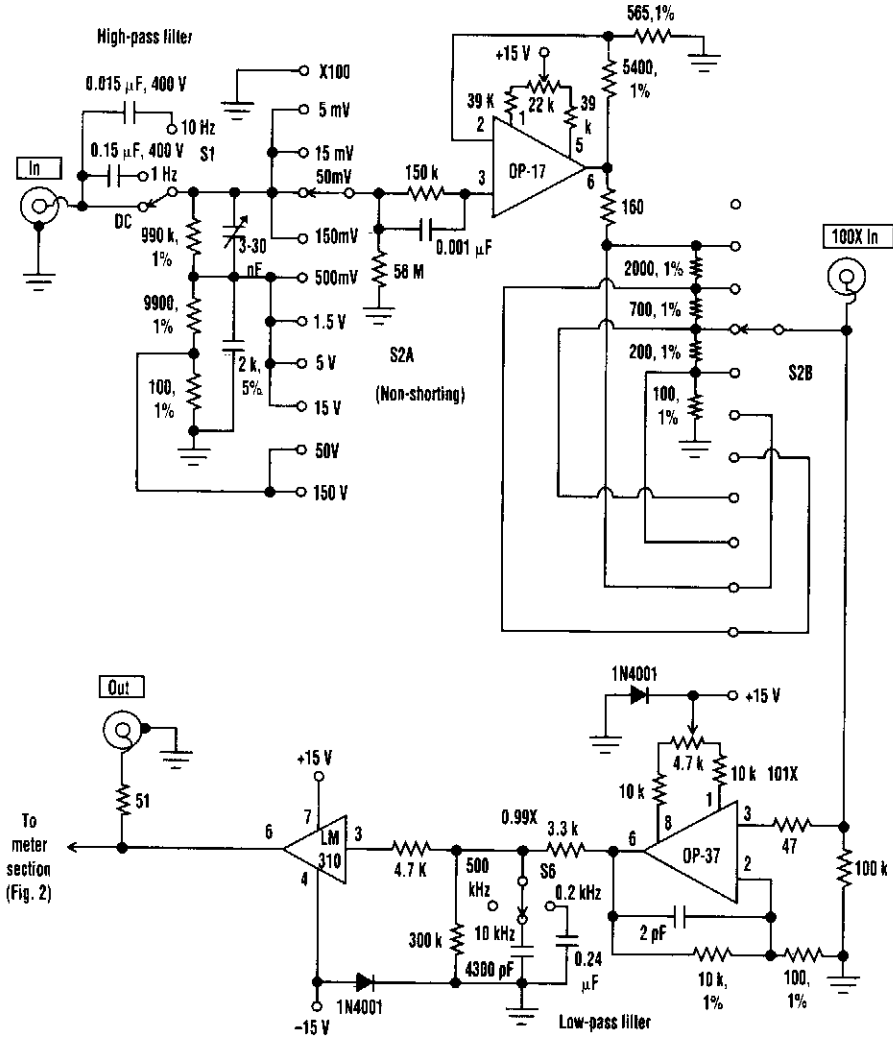

THIS meter scale can be enlarged on a copier and attached to a meter face for the dual-scale ac voltmeter.

ac VOLTMETER HAS UNIQUE FEATURES (Cont.)

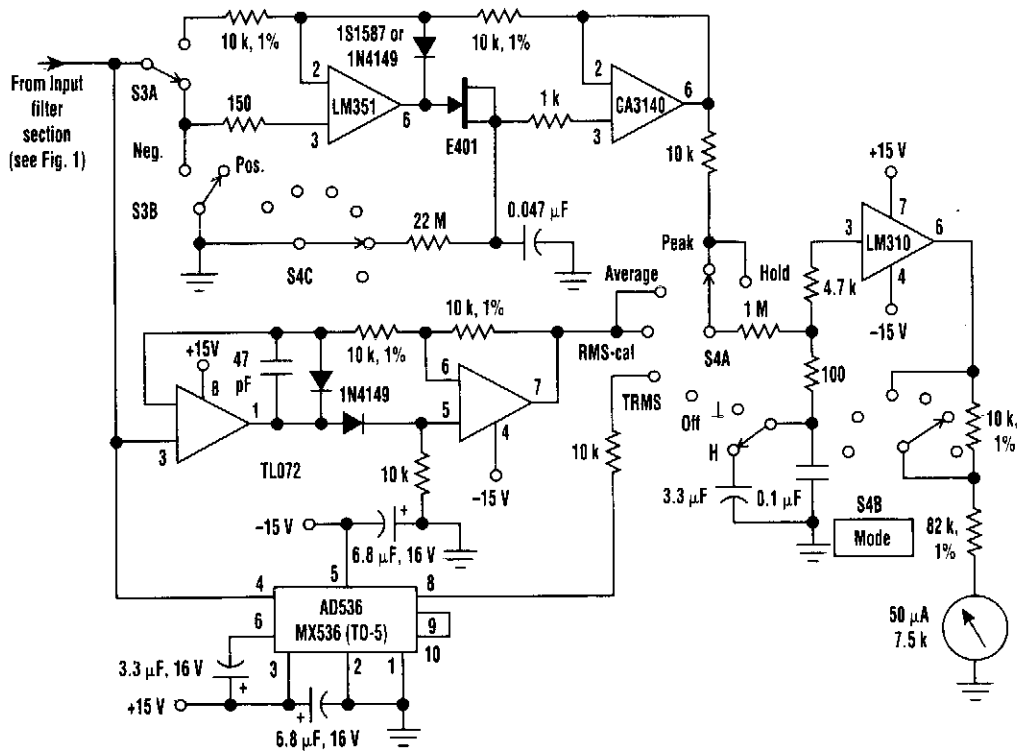

Though it's built with standard components, this ac voltmeter contains many features not typically found in commercial meters; the most unusual is a selection of rectification modes. The meter responses available include true RMS (TRMS), average, RMS-calibrated average responding, positive peak, negative peak, positive-peak hold, and negative-peak hold.

High- and low-pass filters (S1 and S6, respectively) allow the -3-dB-passband to be varied from as little as 10 Hz to 200 Hz, to as wide as dc to 500 kHz. The low-pass filter also is effective in the 100× amplifier mode, where the input equivalent noise level is only 0.3 µV, with 10-kHz roll-off.

dc VOLTMETER

Resistance Values for a DC Voltmeter

V FULL SCALE	R_V [Ω]	R_f [Ω]	R'_f [Ω]
10 mV	100k	1.5M	1.5M
100 mV	1M	1.5M	1.5M
1V	10M	1.5M	1.5M
10V	10M	300k	0
100V	10M	30k	0

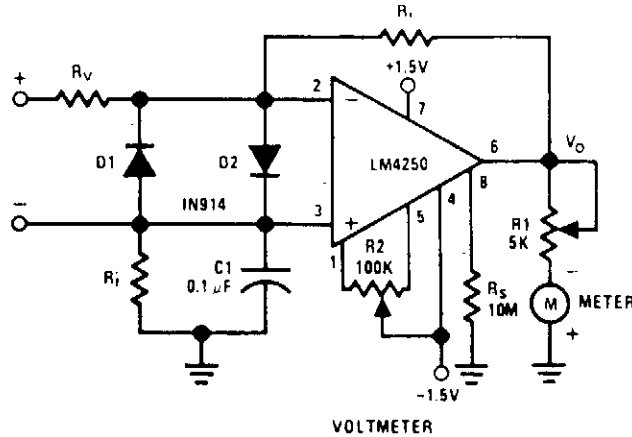

NATIONAL SEMICONDUCTOR

Fig. 101-4

A wide-range voltmeter circuit. This inverting amplifier has a gain varying from -30 for the 10-mV full-scale range to -0.003 for the 100-V full-scale range. Diodes D1 and D2 provide complete amplifier protection for input overvoltages as high as 500 V on the 10-mV range, but if overvoltages of this magnitude are expected under continuous operation, the power rating of R_V should be adjusted accordingly.

EXPANDED-SCALE dc METER FOR 12-V SYSTEMS

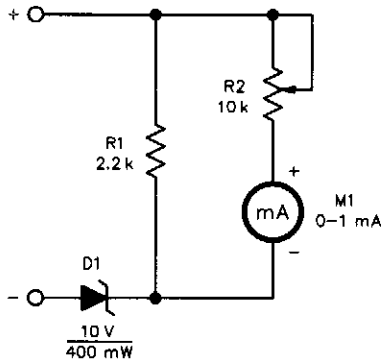

This circuit can be used to monitor a 12-V system with a meter reading 10 V to another voltage. Expect 10 to 20 V, depending on the setting of R2. Depending on the characteristics of D1, R1 might be increased or eliminated entirely.

QST

Fig. 101-5

SIMPLE 3-DIGIT DVM

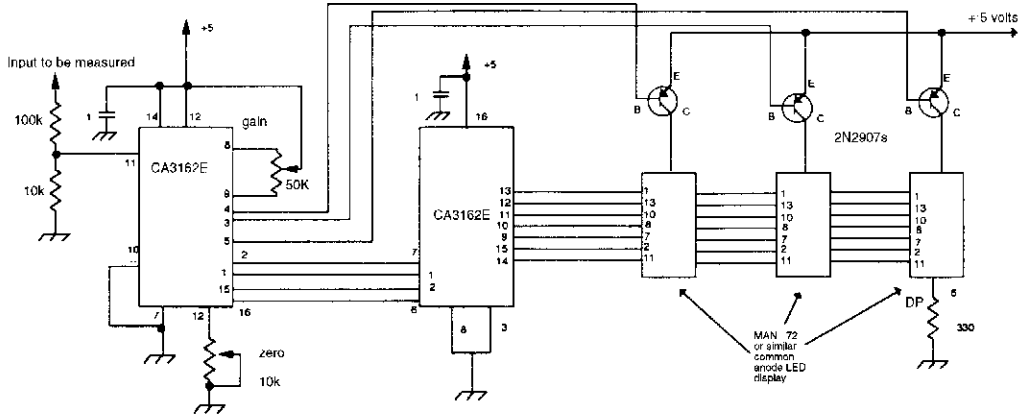

73 AMATEUR RADIO TODAY

Fig. 101-6

A CA3162ZE A-D converter drives a CA3161 BCD decoder/driver and LED display to form a simple DVM circuit. The 50-k Ω gain control and 100-k Ω /10-k Ω voltage divider determine full-scale range.

INEXPENSIVE VOLTAGE CALIBRATOR

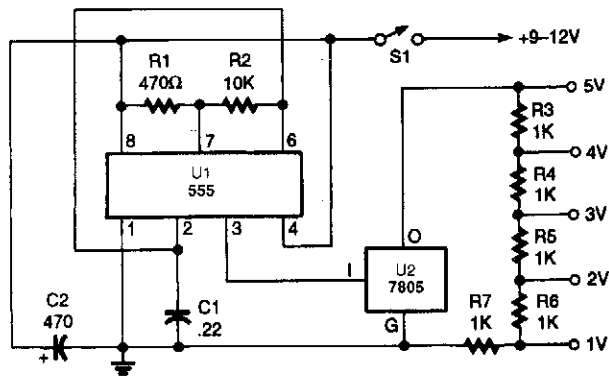

POPULAR ELECTRONICS

Fig. 101-7

In the voltage calibrator, two low-cost ICs—a 555 oscillator/timer and a 78055 5-V 1.5-A voltage regulator—along with a precision voltage divider network are used to provide outputs of 1- to 5-V peak-to-peak.

DOUBLE-ENDED VOLTAGE MONITOR

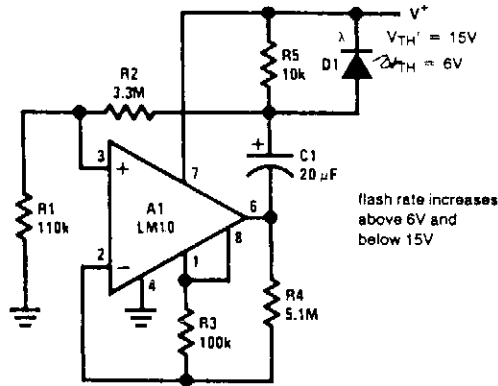

NATIONAL SEMICONDUCTOR

Fig. 101-8

This circuit has the added feature that it can sense an over-voltage condition. The lower activation threshold is given by equation (1), but above a threshold,

$$V_{TH} = \frac{R4(R_1 + R_2) V_{REF}}{R_1(R_3 + R_4) - R3(R_1 + R_2)}$$

oscillation again ceases. Below V_{TH} , the op amp output is saturated negative, but above V_{TH} , it is saturated positive. The flash rate approaches zero near either limit.

AUDIBLE VOLTAGE INDICATOR

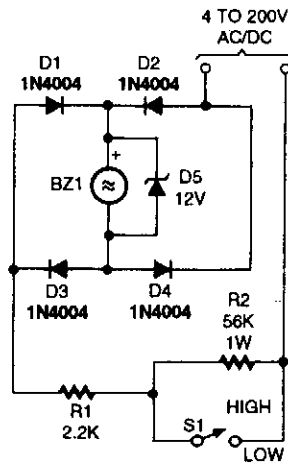

POPULAR ELECTRONICS

Fig. 101-9

The audible voltmeter can be used to test for ac or dc voltages in a circuit. With S1 closed, the circuit can be used to test for voltages between 4 and 24 V, and when S1 is open, it can be used to check for the presence voltages of up to 200 V.

LOW-DRAIN METER AMPLIFIER

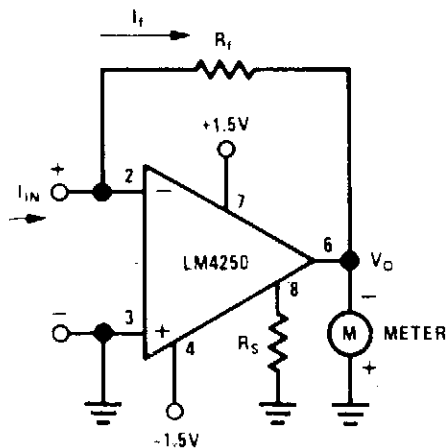

NATIONAL SEMICONDUCTOR

Fig. 101-10

Meter amplifiers normally require one or two 9-V transistor batteries. Because of the heavy current drain on these supplies, the meters must be switched to the OFF position when not in use. The meter circuit described here operates on two 1.5-V flashlight batteries and has a quiescent power drain so low that no on/off switch is needed. A pair of Eveready No. 950 "D" cells will serve for a minimum of one year without replacement. As a dc ammeter, the circuit will provide current ranges as low as 100 nA full-scale.

The basic meter amplifier circuit shown is a current-to-voltage converter. Negative feedback around the amplifier ensures that currents I_{IN} and I_f are always equal, and the high gain of the op amp ensures that the input voltage between pins 2 and 3 is in the microvolt region. Output voltage V_o is therefore equal to $-I_f R_f$. Considering the ± 1.5 -V sources (± 1.2 V end of life) a practical value of V_o for full-scale meter deflection is 300 mV. With the master bias-current setting resistor (R_s) set at $10\text{ M}\Omega$, the total quiescent current drain of the circuit is $0.6\ \mu\text{A}$ for a total power supply drain of $1.8\ \mu\text{W}$. The input bias current, required by the amplifier at this low level of quiescent current, is in the range of 600 pA.

102

Waveform Generator Circuits

The sources of the following circuits are contained in the Sources section, which begins on page 707. The figure number in the box of each circuit correlates to the entry in the Sources section.

- Simple Triangle Waveform Generator
- Triangle-Wave Generator
- Generate Accurate PWM Signals
- Triangle-Wave Generator
- Low-Frequency Pulse Generator
- Sine/Cosine Audio Generator for Galvanometer Experiments
- Basic 555 Monostable
- Op-Amp Sawtooth Generator
- Digital Sine-Wave Generator
- Signal Source for Audio Amplifier/Inverter
- Simple Test Signal Generator

SIMPLE TRIANGLE WAVEFORM GENERATOR

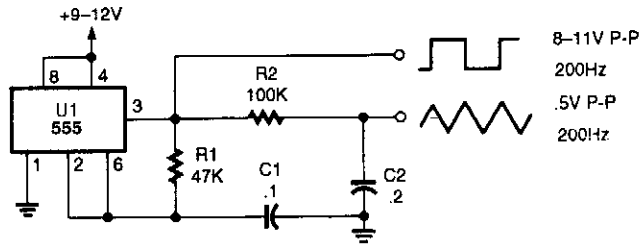

POPULAR ELECTRONICS

Fig. 102-1

The circuit is a triangle waveform-generator circuit that uses as few parts as possible. A 555 timer IC, two resistors, and two capacitors make the triangle waveform. The IC is connected in a 50% duty-cycle astable square-wave oscillator circuit. The square-wave output is fed from pin 3 of the IC to an RC shaping circuit.

When the 555's square-wave output goes high, C₂ begins to charge through R₂ and the voltage across C₂ increases as long as the output remains high. When the IC's output goes low again, C₂ begins to discharge through R₂ reducing the voltage across C₂ as long as the output remains low. The resulting waveform across C₂ takes the shape of a triangle. The best waveform linearity is obtained when R₂ and C₂ are made as large as possible. With the component values shown, the peak-to-peak output is 0.5 V at a frequency of about 200 Hz.

TRIANGLE-WAVE GENERATOR

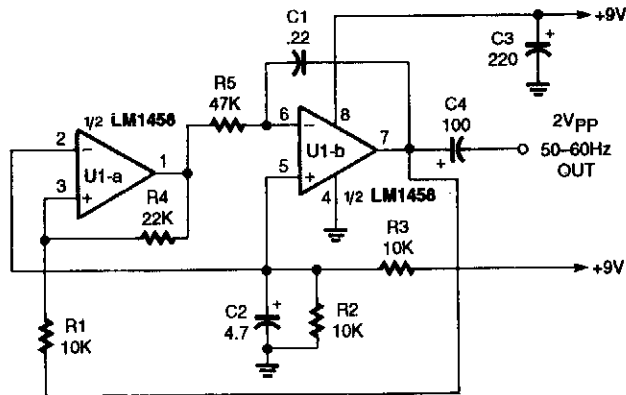

POPULAR ELECTRONICS

Fig. 102-2

This oscillator, which is built around an LM1458 dual op amp and a few inexpensive components, produces a 2-V peak-to-peak, triangular waveform.

GENERATE ACCURATE PWM SIGNALS

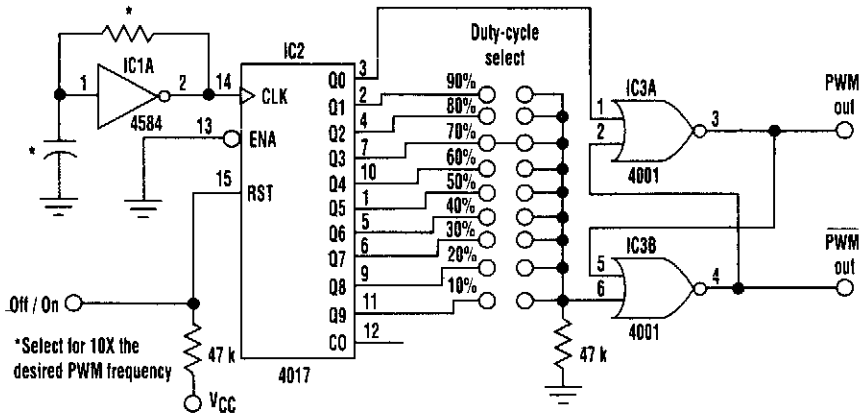

ELECTRONIC DESIGN

Fig. 102-3

Accurate 10 to 90% duty-cycle PWM signals can be generated using this simple circuit setup. The desired duty cycle is selected by a single jumper block. PWM clock IC1 runs at 10x the desired pulse drive frequency. IC2, a 4017 divide-by-10 counter, decodes the clock pulses into one of 10 outputs. Output 0 resets IC3, the PWM latch. The latch stays reset until the desired duty-cycle output set by the jumper block is reached. At this point, the PWM latch is set, and the PWM output line remains high until output 0 is decoded again.

By calling IC2's output (0) the "reset" line for the latch, the PWM output is forced inactive if the jumper strap is removed to change duty cycles without first powering down.

Using the zero-state reset allows IC2's reset pin to be used as an on/off control line for the circuit. The complementary PWM output could be used in a full bridge design.

TRIANGLE-WAVE GENERATOR

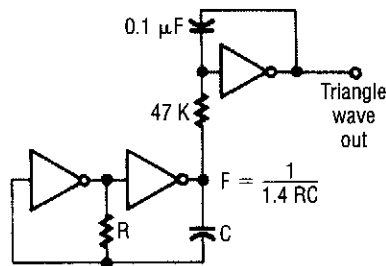

ELECTRONICS NOW

Fig. 102-4

The first two gates are set up as a square-wave oscillator, and the last one makes the conversion to triangle waves.

LOW-FREQUENCY PULSE GENERATOR

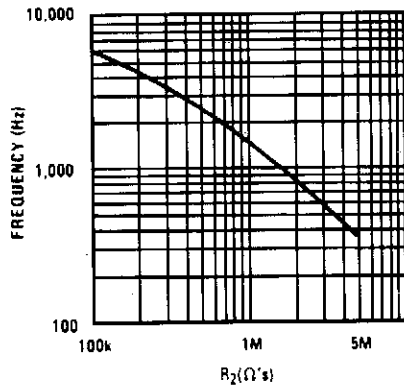
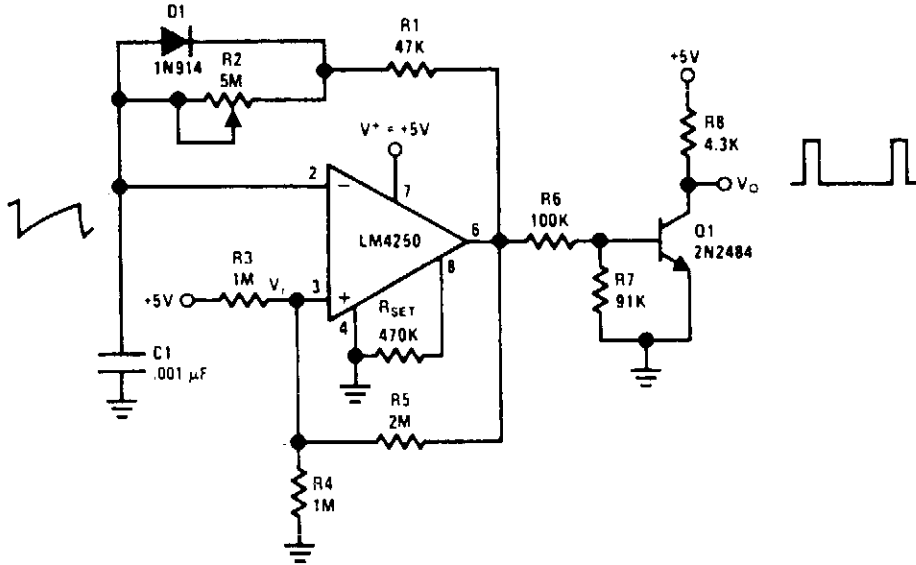

Pulse frequency vs. R_2

SINE/COSINE AUDIO GENERATOR FOR GALVANOMETER EXPERIMENTS

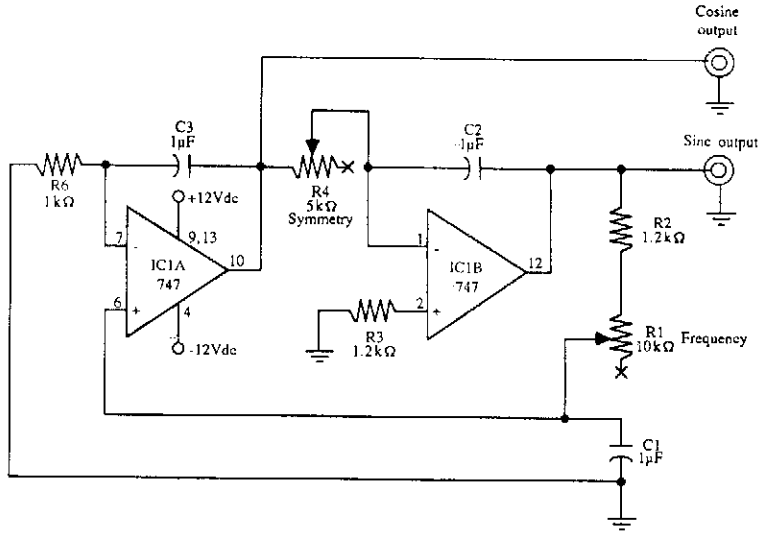

C1 - C3 1 μ F polarized electrolytic
 IC1 LM747 dual op amp IC
 J1, J2 1/8-inch miniature phone jack

All resistors are 5 to 10 percent tolerance, 1/4 watt.
 All capacitors are 10 to 20 percent tolerance, rated at 35 volts or more.

McGRAW-HILL

Fig. 102-6

This circuit shows how to implement a sine/cosine audio generator for operating two galvanometers.

BASIC 555 MONOSTABLE

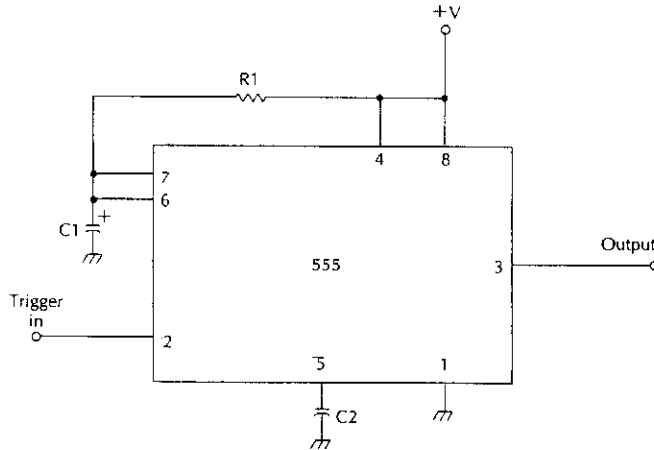

McGRAW-HILL

Fig. 102-7

$$T = 1.1 R_1 C_1$$

OP-AMP SAWTOOTH GENERATOR

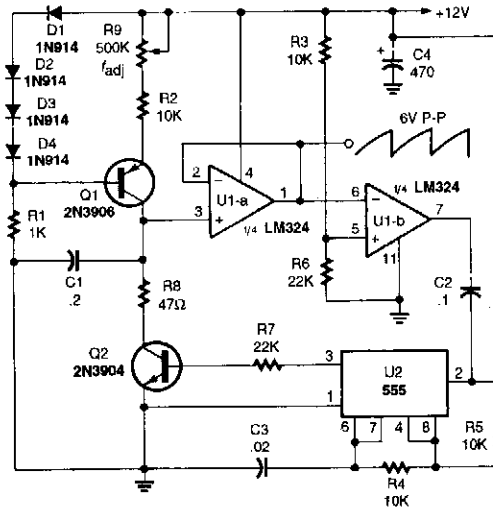

POPULAR ELECTRONICS

Fig. 102-8

The sawtooth generator circuit shown is reset at the end of each cycle. The result is a constant peak-to-peak output throughout the circuit's frequency range.

The constant-current generator circuit, the voltage-follower circuit, and the comparator circuit produce the waveform. A 555 timer IC (U2) is configured as a one-shot multivibrator that's triggered by the comparator's negative output pulse.

DIGITAL SINE-WAVE GENERATOR

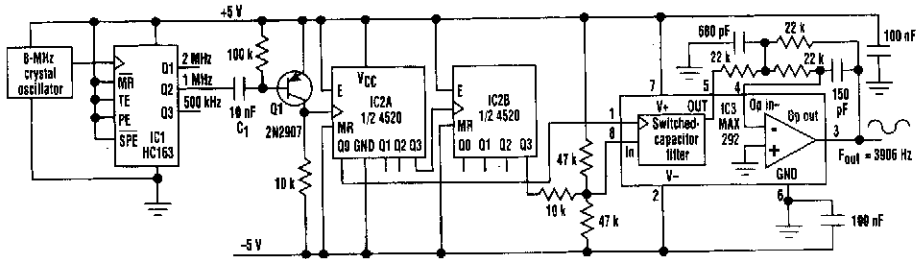

ELECTRONIC DESIGN

Fig. 102-9

The sine-wave generator starts with an 8-MHz signal and divides it by eight to obtain 1 MHz at C1 (IC1's 2-MHz and 500-kHz outputs can serve as alternate drive signals). Q1 level-shifts the 1-MHz pulses so that they can drive the bipolar circuitry necessary for producing a bipolar output. Synchronous counter IC2 divides 1 MHz by 256 to give the desired output frequency (3906 Hz), and IC3 filters the harmonic frequencies.

The filter's clock is taken from the first divide-by-2 tap of IC2 to assure a 50% duty cycle. IC2 further divides this signal by 128 to ensure that the filter's input signal (1 MHz/256) falls within the flat portion of the filter response.

The output of the switched-capacitor filter resembles a sampled sine wave. It can be smoothed by building a first- or second-order low-pass filter around the otherwise uncommitted output op amp.

SIGNAL SOURCE FOR AUDIO AMPLIFIER/INVERTER

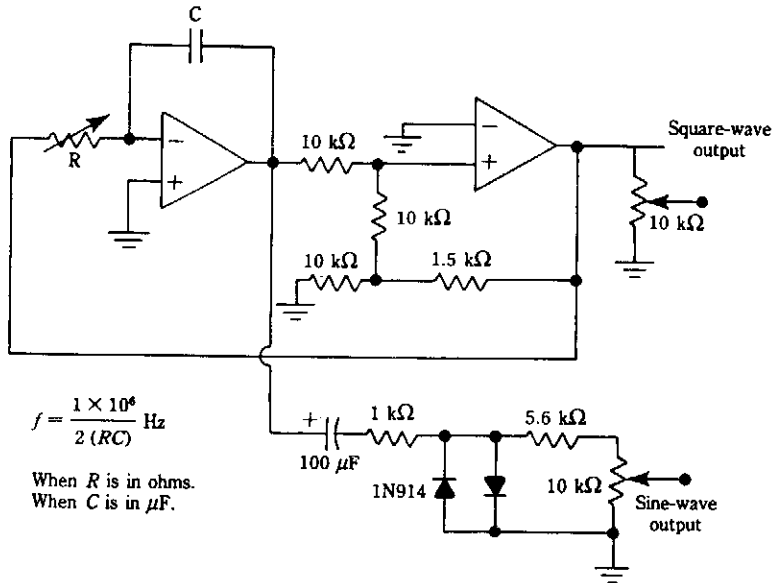

McGRAW-HILL

Fig. 102-10

Two op amps (741, etc..) are used in this oscillator circuit. A square wave is available and a sine wave, obtained by shaping the triangle waveform, is also provided.

SIMPLE TEST SIGNAL GENERATOR

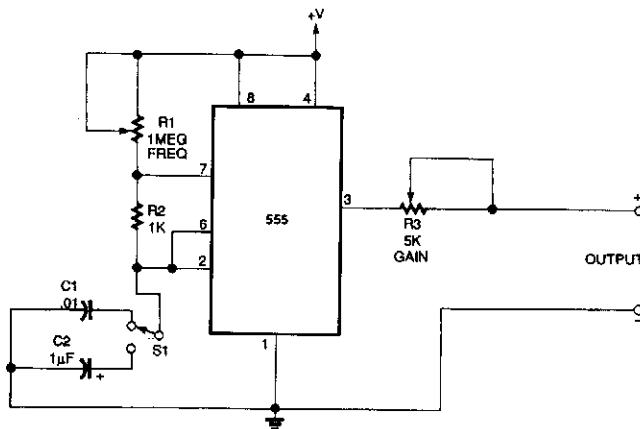

ELECTRONICS NOW

Fig. 102-11

An NE555 generates signals for test purposes. Frequency range is from 20 Hz to 10 kHz, depending on the setting of S1. +V is 5 V.

103

Waveguide Circuits

The sources of the following circuits are contained in the Sources section, which begins on page 707. The figure number in the box of each circuit correlates to the entry in the Sources section.

10-GHz Waveguide Detector for Amateur Radio Use
10-GHz Waveguide Transition for Amateur Radio Use

10-GHz WAVEGUIDE DETECTOR FOR AMATEUR RADIO USE

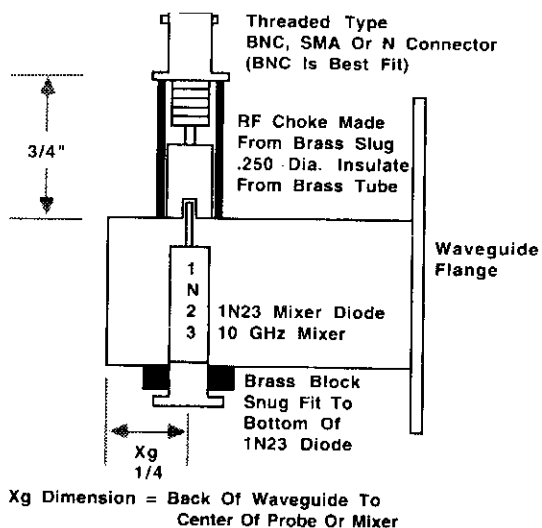

73 AMATEUR RADIO TODAY

Fig. 103-1

This shows the construction of a waveguide detector for use at the 10-GHz amateur radio frequencies.

10-GHz WAVEGUIDE TRANSITION FOR AMATEUR RADIO USE

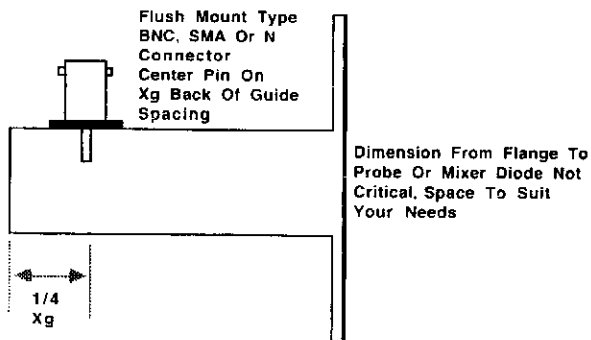

73 AMATEUR RADIO TODAY

Fig. 103-2

A transistor adapts the waveguide to coaxial cable or other types of transmission lines.

104

White-Noise Generator Circuits

The sources of the following circuits are contained in the Sources section, which begins on page 707. The figure number in the box of each circuit correlates to the entry in the Sources section.

Zener-Diode White-Noise Generator
White-Noise Generator

ZENER-DIODE WHITE-NOISE GENERATOR

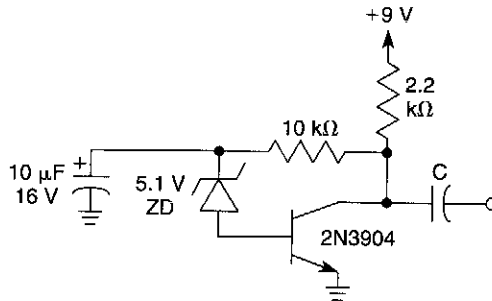

WILLIAM SHEETS

Fig. 104-1

This circuit uses a Zener diode as a noise source. C is chosen to pass the lowest-desired frequency components of the noise.

WHITE-NOISE GENERATOR

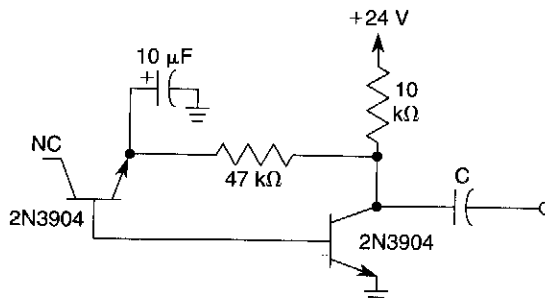

WILLIAM SHEETS

Fig. 104-2

Here, a 2N3904 E-B junction is used as a noise generator, reversed bias. C is chosen to pass the lowest-desired frequency components of the noise.

Sources

Chapter 1

- Fig. 1-1. QST, 2/95, p. 58.
Fig. 1-2. Analog Devices, Analog Dialogue, Vol. 26, No. 2, p. 5.
Fig. 1-3. Reprinted with permission from Electronic Design, 2/95, p. 108. Copyright 1995, Penton Publishing, Inc.
Fig. 1-4. 1994 Experimenters Handbook, p. 113.

Chapter 2

- Fig. 2-1. Reprinted with permission from Electronic Design, 10/94, p. 90. Copyright 1994, Penton Publishing, Inc.
Fig. 2-2. Reprinted with permission from Popular Electronics, 1/94, p. 37. (C) Copyright Gernsback Publications, Inc., 1994.
Fig. 2-3. Reprinted with permission from Popular Electronics, Fact Card No. 270. (C) Copyright Gernsback Publications, Inc.

Chapter 3

- Fig. 3-1. Reprinted with permission from Popular Electronics, 9/94, p. 26. (C) Copyright Gernsback Publications, Inc., 1994.
Fig. 3-2. Reprinted with permission from

Popular Electronics, 10/94, p. 48. (C) Copyright Gernsback Publications, Inc., 1994.

- Fig. 3-3. Reprinted with permission from Popular Electronics, 10/94, p. 35. (C) Copyright Gernsback Publications, Inc., 1994.
Fig. 3-4. Reprinted with permission from Popular Electronics, 10/94, p. 49. (C) Copyright Gernsback Publications, Inc., 1994.
Fig. 3-5. Reprinted with permission from Popular Electronics, 5/95, pp. 69-70. (C) Copyright Gernsback Publications, Inc., 1995.
Fig. 3-6. Reprinted with permission from Popular Electronics, 9/94, p. 24. (C) Copyright Gernsback Publications, Inc., 1994.
Fig. 3-7. Reprinted with permission from Popular Electronics, 2/94, p. 37. (C) Copyright Gernsback Publications, Inc., 1994.
Fig. 3-8. Reprinted with permission from Popular Electronics, 5/95, p. 70. (C) Copyright Gernsback Publications, Inc., 1995.
Fig. 3-9. Reprinted with permission from Popular Electronics, 9/94, p. 25 (C)

Copyright Gernsback Publications, Inc., 1994.

Fig. 3-10. Reprinted with permission from Popular Electronics, 4/95, p. 70. (C) Copyright Gernsback Publications, Inc., 1995.

Fig. 3-11. Reprinted with permission from Popular Electronics, 5/95, p. 71. (C) Copyright Gernsback Publications, Inc., 1995.

Chapter 4

Fig. 4-1. QST, 12/94, p. 36.

Fig. 4-2. QST, 12/94, p. 35.

Fig. 4-3. QST, 12/94, p. 34.

Fig. 4-4. QST, 5/89, pp. 25-27.

Fig. 4-5. 73 Amateur Radio Today, 5/94, pp. 58-59.

Fig. 4-6. 73 Amateur Radio Today, 8/89, p. 60.

Fig. 4-7. QST, 4/95, p. 56.

Fig. 4-8. QST, 7/94, p. 24.

Fig. 4-9. QST, 3/95, p. 28.

Fig. 4-10. QST, 10/94, p. 65.

Fig. 4-11. 73 Amateur Radio Today, 1/95, p. 32.

Fig. 4-12. 73 Amateur Radio Today, 6/83, p. 99.

Fig. 4-13. 73 Amateur Radio Today, 10/94, p. 14.

Fig. 4-14. 73 Amateur Radio Today, 5/94, p. 10.

Fig. 4-15. William Sheets.

Fig. 4-16. QST, 4/95, p. 61.

Fig. 4-17. QST, 10/94, p. 42.

Fig. 4-18. 73 Amateur Radio Today, 6/94, p. 48.

Fig. 4-19. 73 Amateur Radio Today, 6/94, pp. 32-34.

Chapter 5

Fig. 5-1. Reprinted with permission from Electronics Now, 7/94, p. 34. (C) Copyright Gernsback Publications, Inc., 1994.

Fig. 5-2. Reprinted with permission from Electronics Now, 7/94, p. 39. (C) Copyright Gernsback Publications, Inc., 1994.

Fig. 5-3. Reprinted with permission from Electronics Now, 7/94, p. 36. (C) Copyright Gernsback Publications, Inc., 1994.

Fig. 5-4. William Sheets.

Fig. 5-5. 73 Amateur Radio Today, 9/94, p. 62.

Fig. 5-6. QST, 11/94, p. 23.

Fig. 5-7. QST, 12/94, p. 28.

Fig. 5-8. Rudolf F. Graf and William Sheets.

Fig. 5-9. Reprinted with permission from Radio-Electronics, September 1992, p. 79. (C) Copyright Gernsback Publications, Inc., 1994.

Chapter 6

Fig. 6-1. Reprinted with permission from Electronic Design, 11/93, p. 102. Copyright 1993, Penton Publishing, Inc.

Fig. 6-2. Reprinted with permission from Radio-Electronics, Experimenters Handbook, p. 4. (C) Copyright Gernsback Publications, Inc., 1994.

Fig. 6-3. Maxim, Vol. III, New Releases Data Book, 1994, p. 8-17.

Fig. 6-4. Maxim, Vol. III, New Releases Data Book, 1994, p. 8-17.

Fig. 6-5. Reprinted with permission from Electronics Now, 2/94, p. 75. (C) Copyright Gernsback Publications, Inc., 1994.

Fig. 6-6. Reprinted with permission of National Semiconductor Corporation, National Semiconductor Linear Applications Handbook 1991, p. 492.

Fig. 6-7. Amplifiers, Waveform Generators & Other Low-Cost IC Projects, McGraw-Hill, pp. 104-105.

Fig. 6-8. Amplifiers, Waveform Generators & Other Low-Cost IC Projects, McGraw-Hill, p. 107.

Fig. 6-9. Maxim, Vol. III, New Releases Data Book, 1994, p. 3-30.

Fig. 6-10. Maxim, Vol. III, New Releases Data Book, 1994, p. 8-18.

Fig. 6-11. Linear Technology, 2/95.

Fig. 6-12. Maxim, Vol. III, New Releases Data Book, 1994, p. 8-18.

Fig. 6-13. Linear Technology, 2/95.

Fig. 6-14. Reprinted with permission of National Semiconductor Corporation, National Semiconductor Linear Applications Handbook 1991, p. 594.

Fig. 6-15. Power Supplies, Switching Regulators, Inverters, and Converters, McGraw-Hill, pp. 127-128.

- Fig. 6-16. Reprinted with permission of National Semiconductor Corporation, National Semiconductor Linear Applications Handbook 1991, p. 501.
- Fig. 6-17. Reprinted with permission from Electronics Now, 6/94, p. 12. (C) Copyright Gernsback Publications, Inc., 1994.
- Fig. 6-18. Maxim, Vol. III, New Releases Data Book, 1994, p. 8-19.

Chapter 7

- Fig. 7-1. Analog Devices, AD8001 Data Sheet.
- Fig. 7-2. Reprinted with permission from Popular Electronics, 4/94, p. 47. (C) Copyright Gernsback Publications, Inc., 1994.

Chapter 8

- Fig. 8-1. 73 Amateur Radio Today, 12/93, p. 32.
- Fig. 8-2. Reprinted with permission from Electronic Design, 2/95, p. 107. Copyright 1995, Penton Publishing, Inc.
- Fig. 8-3. Reprinted with permission from Electronics Now, 11/93, p. 31. (C) Copyright Gernsback Publications, Inc., 1993.
- Fig. 8-4. Reprinted with permission from Electronics Now, 5/94, p. 49. (C) Copyright Gernsback Publications, Inc., 1994.
- Fig. 8-5. QST, 5/95, p. 35.
- Fig. 8-6. QST, 5/95, p. 35.
- Fig. 8-7. William Sheets.

Chapter 9

- Fig. 9-1. QST, 10/94, p. 47.
- Fig. 9-2. Reprinted with permission from Popular Electronics, 12/94, p. 88. (C) Copyright Gernsback Publications, Inc., 1994.

Chapter 10

- Fig. 10-1. Reprinted with permission from Electronics Now, 6/94, p. 34. (C) Copyright Gernsback Publications, Inc., 1994.
- Fig. 10-2. Reprinted with permission from Electronics Now, 5/93, p. 65. (C) Copyright Gernsback Publications, Inc., 1993.
- Fig. 10-3. William Sheets.
- Fig. 10-4. William Sheets.

- Fig. 10-5. Reprinted with permission from Popular Electronics, 12/94, p. 31. (C) Copyright Gernsback Publications, Inc., 1994.

- Fig. 10-6. William Sheets.
- Fig. 10-7. William Sheets.
- Fig. 10-8. Reprinted with permission from Electronics Now, 8/94, p. 12. (C) Copyright Gernsback Publications, Inc., 1994.
- Fig. 10-9. Analog Devices, The Best of Analog Dialogue, 1967-1992, p. 180.
- Fig. 10-10. Analog Devices, Analog Dialogue, Vol. 27, No. 2 (1993), p. 22.
- Fig. 10-11. Reprinted with permission from Popular Electronics, Fact Card No. 229. (C) Copyright Gernsback Publications, Inc.
- Fig. 10-12. William Sheets.
- Fig. 10-13. William Sheets.
- Fig. 10-14. William Sheets.
- Fig. 10-15. William Sheets.
- Fig. 10-16. Analog Devices, The Best of Analog Dialogue, 1967-1991, p. 180.
- Fig. 10-17. William Sheets.
- Fig. 10-18. William Sheets.
- Fig. 10-19. Gordon McComb's Gadgeteer's Goldmine, McGraw-Hill, p. 329.

Chapter 11

- Fig. 11-1. William Sheets.
- Fig. 11-2. Reprinted with permission of National Semiconductor Corporation, National Semiconductor Linear Applications Handbook 1991, p. 1058.
- Fig. 11-3. William Sheets.
- Fig. 11-4. Reprinted with permission of National Semiconductor Corporation, National Semiconductor Linear Applications Handbook 1991, p. 1060.
- Fig. 11-5. Reprinted with permission of National Semiconductor Corporation, National Semiconductor Linear Applications Handbook 1991, p. 253.
- Fig. 11-6. William Sheets.
- Fig. 11-7. Reprinted with permission from Popular Electronics, 1/95, p. 54. (C) Copyright Gernsback Publications, Inc., 1995.
- Fig. 11-8. Reprinted with permission from

Popular Electronics, 1/95, p. 54. (C) Copyright Gernsback Publications, Inc., 1995.

Fig. 11-9. Reprinted with permission of National Semiconductor Corporation, National Semiconductor Linear Application Specific IC's Databook 1993, p. 1-14.

Fig. 11-10. William Sheets.

Fig. 11-11. William Sheets.

Fig. 11-12. Reprinted with permission of National Semiconductor Corporation, National Semiconductor Linear Applications Handbook 1991, p. 199.

Fig. 11-13. William Sheets.

Fig. 11-14. Reprinted with permission of National Semiconductor Corporation, National Semiconductor Linear Applications Handbook, 1991, p. 198.

Fig. 11-15. Reprinted with permission of National Semiconductor Corporation, National Semiconductor Linear Edge, #8, p. 14.

Fig. 11-16. William Sheets.

Fig. 11-17. QST, 12/94, p. 44.

Fig. 11-18. Reprinted with permission of National Semiconductor Corporation, National Semiconductor Linear Applications Handbook 1991, p. 1059.

Fig. 11-19. Reprinted with permission of National Semiconductor Corporation, National Semiconductor Linear Applications Handbook 1991, p. 1059.

Fig. 11-20. Reprinted with permission from Popular Electronics, 5/94, p. 80. (C) Copyright Gernsback Publications, Inc., 1994.

Chapter 12

Fig. 12-1. Reprinted with permission from Popular Electronics, 4/95, p. 47. (C) Copyright Gernsback Publications, Inc., 1995.

Fig. 12-2. Reprinted with permission from Popular Electronics, 3/95, p. 67. (C) Copyright Gernsback Publications, Inc., 1995.

Fig. 12-3. William Sheets.

Fig. 12-4. William Sheets.

Fig. 12-5. Reprinted with permission from Popular Electronics, 4/95, p. 70. (C) Copyright Gernsback Publications, Inc., 1995.

Fig. 12-6. Electronics Now, 4/94, p. 25.

Fig. 12-7. Reprinted with permission from Popular Electronics, 5/95, p. 69. (C) Copyright Gernsback Publications, Inc., 1995.

Fig. 12-8. Reprinted with permission from Radio-Electronics, June 1984, p. 39. (C) Copyright Gernsback Publications, Inc., 1984.

Fig. 12-9. Reprinted with permission from Radio-Electronics, 1994 Electronics Experimenters Handbook, p. 37. (C) Copyright Gernsback Publications, Inc., 1994.

Fig. 12-10. William Sheets.

Fig. 12-11. Power Supplies, Switching Regulators, Inverters, and Converters, McGraw-Hill, p. 104.

Fig. 12-12. Reprinted with permission from Popular Electronics, 6/95, p. 32. (C) Copyright Gernsback Publications, Inc., 1995.

Fig. 12-13. Reprinted with permission from Popular Electronics, 4/95, p. 68. (C) Copyright Gernsback Publications, Inc., 1995.

Fig. 12-14. Reprinted with permission from Popular Electronics, 4/95, p. 68. (C) Copyright Gernsback Publications, Inc., 1995.

Fig. 12-15. Electronics Now, 4/95, p. 18.

Fig. 12-16. Reprinted with permission from Popular Electronics, 6/95, p. 30. (C) Copyright Gernsback Publications, Inc., 1995.

Chapter 13

Fig. 13-1. Reprinted with permission from Electronics Now, 5/95, p. 65. (C) Copyright Gernsback Publications, Inc., 1995.

Fig. 13-2. Reprinted with permission from Electronics Now, 10/94, pp. 65-66. (C) Copyright Gernsback Publications, Inc., 1994.

Fig. 13-3. William Sheets.

Fig. 13-4. Reprinted with permission from

Electronic Design, 6/94, pp. 42–43. Copyright 1994, Penton Publishing, Inc.

- Fig. 13-5. Reprinted with permission from Popular Electronics, 6/95, p. 32. (C) Copyright Gernsback Publications, Inc., 1995.
- Fig. 13-6. Reprinted with permission from Electronic Design, 6/94, p. 42. Copyright 1994, Penton Publishing, Inc.
- Fig. 13-7. Linear Technology, Design Note #98.
- Fig. 13-8. 73 Amateur Radio Today, 6/93, p. 41.
- Fig. 13-9. 73 Amateur Radio Today, 6/93, p. 35.
- Fig. 13-10. Reprinted with permission from Electronic Design, 6/94, p. 42. Copyright 1994, Penton Publishing, Inc.
- Fig. 13-11. Reprinted with permission from Popular Electronics, 6/93, p. 76. (C) Copyright Gernsback Publications, Inc., 1993.
- Fig. 13-12. 73 Amateur Radio Today, 5/93, p. 69.

Chapter 14

- Fig. 14-1. Reprinted with permission from Electronic Design, 1/95, pp. 81–82. Copyright 1995, Penton Publishing, Inc.
- Fig. 14-2. Spring 1994 Electronics Hobbyist Handbook.
- Fig. 14-3. Reprinted with permission of National Semiconductor Corporation, National Semiconductor Linear Applications Handbook 1991, p. 499.
- Fig. 14-4. Reprinted with permission from Popular Electronics, 3/92, p. 74. (C) Copyright Gernsback Publications, Inc., 1992.
- Fig. 14-5. Maxim, Vol. III, New Releases Data Book, 1994, p. 529.
- Fig. 14-6. Reprinted with permission from Radio-Electronics, June 1984, p. 90.
- Fig. 14-7. Reprinted with permission of National Semiconductor Corporation, National Semiconductor Linear Applications Handbook 1991, p. 498.
- Fig. 14-8. QST, 10/94, p. 75.
- Fig. 14-9. Laser Cookbook, McGraw-Hill, p. 183.

Chapter 15

- Fig. 15-1. Reprinted with permission of Burr-Brown Corporation, Burr-Brown Data Sheet INA118, (C) 1989–1995 Burr-Brown Corporation.
- Fig. 15-2. Reprinted with permission from Popular Electronics, 3/94, p. 83. (C) Copyright Gernsback Publications, Inc., 1994.
- Fig. 15-3. Reprinted with permission from Popular Electronics, Fact Card No. 248. (C) Copyright Gernsback Publications, Inc.

Chapter 16

- Fig. 16-1. Analog Devices, The Best of Analog Dialogue, 1967–1991, p. 180.
- Fig. 16-2. William Sheets.
- Fig. 16-3. Analog Devices, Analog Dialogue, Vol. 26, No. 2, 1992, p. 17.
- Fig. 16-4. Analog Devices, Analog Dialogue, Vol. 26, No. 1, 1992, p. 12.
- Fig. 16-5. Reprinted with permission of National Semiconductor Corporation, National Semiconductor Linear Applications Handbook 1991, p. 542.
- Fig. 16-6. Analog Devices, The Best of Analog Dialogue, 1967–1991, p. 117.
- Fig. 16-7. Reprinted with permission of National Semiconductor Corporation, National Semiconductor Linear Applications Handbook 1991, p. 543.
- Fig. 16-8. Reprinted with permission from Electronic Design, 8/94, p. 104. Copyright 1994, Penton Publishing, Inc.
- Fig. 16-9. Linear Technology, Design Note #89.

Chapter 17

- Fig. 17-1. Reprinted with permission from Electronic Design, 11/94, p. 115. Copyright 1994, Penton Publishing, Inc.
- Fig. 17-2. Reprinted with permission from Electronics Now, 3/95, p. 8. (C) Copyright Gernsback Publications, Inc., 1995.

Chapter 18

- Fig. 18-1. Reprinted with permission from Electronic Design, 4/89, p. 108. Copyright 1989, Penton Publishing, Inc.

- Fig. 18-2. Reprinted with permission from Electronic Design, 10/94, pp. 107–108. Copyright 1994, Penton Publishing, Inc.
- Fig. 18-3. 1994 Electronic Experimenters Handbook, p. 99.
- Fig. 18-4. Reprinted with permission from Electronic Design, 12/94, p. 115. Copyright 1994, Penton Publishing, Inc.
- Fig. 18-5. Maxim, Vol. III, New Releases Data Book, 1994, p. 5-17.
- Fig. 18-6. Reprinted with permission from Electronic Design, 10/94, p. 101. Copyright 1994, Penton Publishing, Inc.
- Fig. 18-7. Maxim, Vol. III, New Releases Data Book, 1994, p. 4-107.
- Fig. 18-8. Reprinted with permission from Electronic Design, 1/84, p. 440. Copyright 1984, Penton Publishing, Inc.
- Fig. 18-9. Reprinted with permission from Electronics Now, 5/95, p. 44. (C) Copyright Gernsback Publications, Inc., 1994.

Chapter 19

- Fig. 19-1. Reprinted with permission from Electronic Design, 3/95, p. 111. Copyright 1995, Penton Publishing, Inc.
- Fig. 19-2. Reprinted with permission from Electronics Now, 8/94, p. 8. (C) Copyright Gernsback Publications, Inc., 1994.
- Fig. 19-3. Reprinted with permission from Electronics Now, 4/95, p. 83. (C) Copyright Gernsback Publications, Inc., 1995.
- Fig. 19-4. Sound Light and Music, Delton T. Horn, McGraw-Hill, p. 168.

Chapter 20

- Fig. 20-1. Radio Craft, 1993, p. 64.
- Fig. 20-2. William Sheets.
- Fig. 20-3. Power Supplies, Switching Regulators, Inverters, and Converters, McGraw-Hill, p. 97.
- Fig. 20-4. Analog Devices, Analog Dialogue, Vol. 27, No. 2 (1993), p. 21.
- Fig. 20-5. Power Supplies, Switching Regulators, Inverters, and Converters, McGraw-Hill, p. 103.
- Fig. 20-6. William Sheets.
- Fig. 20-7. Power Supplies, Switching Regulators, Inverters, and Converters, McGraw-Hill, pp. 170–173.

- Fig. 20-8. Maxim, Vol. III, New Releases Data Book, 1994, p. 4-79.
- Fig. 20-9. Reprinted with permission from Electronic Design, 11/93, p. 89. Copyright 1995, Penton Publishing, Inc.
- Fig. 20-10. Reprinted with permission of Burr-Brown Corporation, Burr-Brown Data Sheet INA118, (C) 1989–1995 Burr-Brown Corporation.
- Fig. 20-11. Reprinted with permission from Radio-Electronics Experimenters Handbook, p. 76. (C) Copyright Gernsback Publications, Inc., 1994.
- Fig. 20-12. Reprinted with permission from Radio-Electronics Experimenters Handbook, p. 76. (C) Copyright Gernsback Publications, Inc., 1994.
- Fig. 20-13. Amplifiers, Waveform Generators & Other Low-Cost IC Projects, McGraw-Hill, pp. 65–66.
- Fig. 20-14. Reprinted with permission from Electronic Design, 3/95, p. 96. Copyright 1995, Penton Publishing, Inc.
- Fig. 20-15. Reprinted with permission from Electronic Design, 3/95, pp. 94–96. Copyright 1995, Penton Publishing, Inc.
- Fig. 20-16. Analog Devices, The Best of Analog Dialogue, 1967–1991, p. 75.

Chapter 21

- Fig. 21-1. Reprinted with permission from Popular Electronics, 2/94, p. 80. (C) Copyright Gernsback Publications, Inc., 1994.
- Fig. 21-2. Reprinted with permission from Popular Electronics, 2/94, p. 81. (C) Copyright Gernsback Publications, Inc., 1994.
- Fig. 21-3. Reprinted with permission from Popular Electronics, 2/94, p. 81. (C) Copyright Gernsback Publications, Inc., 1994.
- Fig. 21-4. Reprinted with permission from Popular Electronics, 2/94, p. 80. (C) Copyright Gernsback Publications, Inc., 1994.
- Fig. 21-5. William Sheets.
- Fig. 21-6. Reprinted with permission from Popular Electronics, 2/94, p. 90. (C) Copyright Gernsback Publications, Inc., 1994.

- Fig. 21-7. William Sheets.
- Fig. 21-8. Reprinted with permission from Radio-Electronics Experimenters Handbook, p. 75. (C) Copyright Gernsback Publications, Inc., 1994.
- Fig. 21-9. Reprinted with permission from Radio-Electronics Experimenters Handbook, p. 76. (C) Copyright Gernsback Publications, Inc., 1994.
- Fig. 21-10. Radio Craft, 1993, p. 63.
- Fig. 21-11. Reprinted with permission from Radio-Electronics Experimenters Handbook, p. 76. (C) Copyright Gernsback Publications, Inc., 1994.

Chapter 22

- Fig. 22-1. Reprinted with permission from Popular Electronics, 5/95, pp. 30-31. (C) Copyright Gernsback Publications, Inc., 1995.
- Fig. 22-2. Reprinted with permission of National Semiconductor Corporation, National Semiconductor Linear Applications Handbook 1991, p. 245.
- Fig. 22-3. Reprinted with permission of National Semiconductor Corporation, National Semiconductor Linear Applications Handbook 1991, p. 245.
- Fig. 22-4. Reprinted with permission of National Semiconductor Corporation, National Semiconductor Linear Applications Handbook, 1991, p. 245.

Chapter 23

- Fig. 23-1. 73 Amateur Radio Today, 3/95, p. 62.
- Fig. 23-2. William Sheets.
- Fig. 23-3. Linear Technology, Design Note #86.
- Fig. 23-4. Maxim, Vol. III, New Releases Data Book, 1994, p. 4-92.
- Fig. 23-5. Reprinted with permission from Popular Electronics, 1/94, p. 73. (C) Copyright Gernsback Publications, Inc., 1994.

Chapter 24

- Fig. 24-1. Reprinted with permission from Electronics Now, 11/93, p. 53. (C) Copyright Gernsback Publications, Inc., 1993.

- Fig. 24-2. Reprinted with permission of National Semiconductor Corporation, National Semiconductor Linear Applications Handbook 1991, p. 300.

Fig. 24-3. William Sheets.

- Fig. 24-4. Reprinted with permission from Electronics Now, 3/95, p. 86. (C) Copyright Gernsback Publications, Inc., 1995.

- Fig. 24-5. Reprinted with permission from Electronics Now, 3/95, p. 86. (C) Copyright Gernsback Publications, Inc., 1995.

Chapter 25

- Fig. 25-1. Reprinted with permission of National Semiconductor Corporation, National Semiconductor Linear Applications Handbook 1991, p. 267.

- Fig. 25-2. Reprinted with permission from Electronics Now, 8/93, p. 12. (C) Copyright Gernsback Publications, Inc., 1993.

Chapter 26

- Fig. 26-1. Reprinted with permission of National Semiconductor Corporation, National Semiconductor Linear Applications Handbook, 1991, p. 541.

- Fig. 26-2. Reprinted with permission from Electronic Design, 12/94, p. 129. Copyright 1994, Penton Publishing, Inc.

- Fig. 26-3. 1994 Analog Application Issue, Electronic Design, June 27, 1994.

- Fig. 26-4. Reprinted with permission from Popular Electronics, 10/94, p. 82. (C) Copyright Gernsback Publications, Inc., 1994.

- Fig. 26-5. Reprinted with permission from Popular Electronics, 12/94, p. 30. (C) Copyright Gernsback Publications, Inc., 1994.

- Fig. 26-6. Reprinted with permission from Electronics Now, 3/94, p. 68. (C) Copyright Gernsback Publications, Inc., 1994.

- Fig. 26-7. Reprinted with permission of National Semiconductor Corporation, National Semiconductor Linear Applications Handbook, 1991, p. 271.

- Fig. 26-8. Reprinted with permission from Popular Electronics, Fact Card No. 249. (C) Copyright Gernsback Publications, Inc.

- Fig. 26-9. Reprinted with permission of National Semiconductor Corporation, National Semiconductor Linear Applications Handbook, 1991, p. 271.
- Fig. 26-10. Reprinted with permission from Electronic Design, 9/94, p. 136. Copyright 1994, Penton Publishing, Inc.
- Fig. 26-11. Reprinted with permission from Electronic Design, 1/95, p. 81. Copyright 1995, Penton Publishing, Inc.
- Fig. 26-12. Reprinted with permission from Electronics Now, 11/93, p. 8. (C) Copyright Gernsback Publications, Inc., 1993.
- Fig. 26-13. Reprinted with permission from Electronics Now, 3/94, p. 67. (C) Copyright Gernsback Publications, Inc., 1994.
- Fig. 26-14. Reprinted with permission from Electronic Design, 5/90, p. 79. Copyright 1990, Penton Publishing, Inc.
- Fig. 26-15. Reprinted with permission from Popular Electronics, Fact Card No. 270. (C) Copyright Gernsback Publications, Inc.
- Fig. 26-16. Reprinted with permission from Popular Electronics, Fact Card No. 270. (C) Copyright Gernsback Publications, Inc.
- Fig. 26-17. Reprinted with permission from Popular Electronics, Fact Card No. 269. (C) Copyright Gernsback Publications, Inc.
- Fig. 26-18. Reprinted with permission from Popular Electronics, Fact Card No. 269. (C) Copyright Gernsback Publications, Inc.
- Fig. 26-19. Linear Technology, Design Note 88.
- Fig. 26-20. Reprinted with permission from Popular Electronics, 10/94, p. 82. (C) Copyright Gernsback Publications, Inc., 1994.

Chapter 27

- Fig. 27-1. Amplifiers, Waveform Generators & Other Low-Cost IC Projects, McGraw-Hill, p. 37.
- Fig. 27-2. Maxim, Vol. III, New Releases Data Book, 1994, p. 3-45.

Chapter 28

- Fig. 28-1. Reprinted with permission from Electronics Now, 3/95, p. 64. (C) Copyright Gernsback Publications, Inc., 1995.
- Fig. 28-2. Reprinted with permission from Popular Electronics, 1/94, p. 24. (C) Copyright Gernsback Publications, Inc., 1994.
- Fig. 28-3. Reprinted with permission from Popular Electronics, 1/94, p. 25. (C) Copyright Gernsback Publications, Inc., 1994.
- Fig. 28-4. Linear Technology, Advertisement.
- Fig. 28-5. Maxim, Vol. III, New Releases Data Book, 1994, p. 3-127.
- Fig. 28-6. Sound Light and Music, Delton T. Horn, McGraw-Hill, pp. 132-135.
- Fig. 28-7. Reprinted with permission from Popular Electronics, 2/94, p. 26. (C) Copyright Gernsback Publications, Inc., 1994.
- Fig. 28-8. Reprinted with permission from Electronic Design, 12/93, p. 74. Copyright 1993, Penton Publishing, Inc.
- Fig. 28-9. Reprinted with permission from Electronics Now, 3/95, p. 61. (C) Copyright Gernsback Publications, Inc., 1994.

Chapter 29

- Fig. 29-1. Linear Technology, 2/95.
- Fig. 29-2. Analog Devices, Analog Dialogue, Vol. 26, No. 2, 1992, p. 18.
- Fig. 29-3. Reprinted with permission from Popular Electronics, 10/94, p. 24. (C) Copyright Gernsback Publications, Inc., 1994.
- Fig. 29-4. Analog Devices, Analog Dialogue, Vol. 26, No. 2, 1992, p. 12.
- Fig. 29-5. Reprinted with permission of National Semiconductor Corporation, National Semiconductor Linear Applications Handbook, 1991, p. 542.
- Fig. 29-6. Reprinted with permission from Popular Electronics, 1/94, p. 24. (C) Copyright Gernsback Publications, Inc., 1994.
- Fig. 29-7. 73 Amateur Radio Today, 3/95, p. 62.

- Fig. 29-8. Reprinted with permission from Popular Electronics, 11/94, p. 31. (C) Copyright Gernsback Publications, Inc., 1994.
- Fig. 29-9. Analog Devices, Analog Dialogue, Vol. 27, No. 1 (1993), p. 17.
- Fig. 29-10. Reprinted with permission from Electronic Design, 7/94, p. 62. Copyright 1994, Penton Publishing, Inc.
- Fig. 29-11. Reprinted with permission of National Semiconductor Corporation, National Semiconductor Linear Applications Handbook, 1991, p. 541.
- Fig. 29-12. Analog Devices, Analog Dialogue, Vol. 27, No. 1 (1993), p. 16.
- Fig. 29-13. Reprinted with permission from Electronic Design, 9/94, p. 135. Copyright 1994, Penton Publishing, Inc.

Chapter 30

- Fig. 30-1. Reprinted with permission from Popular Electronics, 4/95, pp. 29–30. (C) Copyright Gernsback Publications, Inc., 1995.
- Fig. 30-2. Reprinted with permission from Popular Electronics, 4/95, p. 31. (C) Copyright Gernsback Publications, Inc., 1995.
- Fig. 30-3. Reprinted with permission from Popular Electronics, 4/95, p. 30. (C) Copyright Gernsback Publications, Inc., 1995.

Chapter 31

- Fig. 31-1. Laser Cookbook, McGraw-Hill, p. 231.
- Fig. 31-2. Laser Cookbook, McGraw-Hill, p. 231.

Chapter 32

- Fig. 32-1. Reprinted with permission from Electronic Design, 2/95, p. 115. Copyright 1995, Penton Publishing, Inc.
- Fig. 32-2. Amplifiers, Waveform Generators, & Other Low-Cost IC Projects, McGraw-Hill, p. 186.
- Fig. 32-3. Amplifiers, Waveform Generators & Other Low-Cost IC Projects, McGraw-Hill, p. 193.

- Fig. 32-4. Radio-Electronics Experimenters Handbook, p. 66.
- Fig. 32-5. Reprinted with permission from Electronic Design, 12/94, p. 134. Copyright 1994, Penton Publishing, Inc.
- Fig. 32-6. Reprinted with permission from Electronic Design, 9/94, p. 79. Copyright 1994, Penton Publishing, Inc.
- Fig. 32-7. William Sheets.
- Fig. 32-8. Reprinted with permission from Popular Electronics, 12/94, p. 42. (C) Copyright Gernsback Publications, Inc., 1994.
- Fig. 32-9. Reprinted with permission of National Semiconductor Corporation, National Semiconductor Linear Applications Handbook, 1991, p. 1202.
- Fig. 32-10. Radio Receiver Projects You Can Build, McGraw-Hill, p. 165.
- Fig. 32-11. Radio Receiver Projects You Can Build, McGraw-Hill, p. 291.
- Fig. 32-12. Reprinted with permission from Electronic Design, 8/94, p. 102. Copyright 1994, Penton Publishing, Inc.
- Fig. 32-13. Amplifiers, Waveform, Generators & Other Low-Cost IC Projects, McGraw-Hill, p. 178.
- Fig. 32-14. Reprinted with permission of National Semiconductor Corporation, National Semiconductor Linear Applications Handbook, 1991, p. 229.
- Fig. 32-15. Linear Technology, 2/95.
- Fig. 32-16. Reprinted with permission of National Semiconductor Corporation, National Semiconductor Linear Applications Handbook, 1991, p. 1187.
- Fig. 32-17. Reprinted with permission of National Semiconductor Corporation, National Semiconductor Linear Applications Handbook, 1991, p. 1187.
- Fig. 32-18. Amplifiers, Waveform Generators & Other Low-Cost IC Projects, McGraw-Hill, p. 222.
- Fig. 32-19. Analog Devices, The Best of Analog Dialogue, 1967–1991, p. 79.
- Fig. 32-20. Reprinted with permission of National Semiconductor Corporation, National Semiconductor Linear Applications Handbook, 1991, p. 1032.

- Fig. 32-21. Linear Technology, Design Note #84.
- Fig. 32-22. Reprinted with permission of National Semiconductor Corporation, National Semiconductor Linear Applications Handbook, 1991, p. 1202.
- Fig. 32-23. Amplifiers, Waveform Generators, & Other Low-Cost IC Projects, McGraw-Hill, p. 186.
- Fig. 32-24. Amplifiers, Waveform Generators, & Other Low-Cost IC Projects, McGraw-Hill, p. 185.
- Fig. 32-25. Amplifiers, Waveform Generators & Other Low-Cost IC Projects, McGraw-Hill, p. 201.
- Fig. 32-26. Linear Technology, Design Note #89.
- Fig. 32-27. Reprinted with permission of National Semiconductor Corporation, National Semiconductor Linear Applications Handbook, 1991, p. 1015.
- Fig. 32-28. Reprinted with permission of National Semiconductor Corporation, National Semiconductor Linear Applications Handbook, 1991, p. 228.

Chapter 33

- Fig. 33-1. Reprinted with permission from Popular Electronics, 5/95, pp. 57-59. (C) Copyright Gernsback Publications, Inc., 1995.
- Fig. 33-2. Reprinted with permission from Popular Electronics, 6/95, p. 77. (C) Copyright Gernsback Publications, Inc., 1995.
- Fig. 33-3. Reprinted with permission from Popular Electronics, 6/95, p. 78. (C) Copyright Gernsback Publications, Inc., 1995.
- Fig. 33-4. Reprinted with permission from Popular Electronics, 1/94, p. 73. (C) Copyright Gernsback Publications, Inc., 1994.
- Fig. 33-5. Sound Light and Music, Delton T. Horn, McGraw-Hill, p. 34.
- Fig. 33-6. Reprinted with permission from Popular Electronics, 5/93, p. 70. (C)

Copyright Gernsback Publications, Inc., 1993.

- Fig. 33-7. Reprinted with permission from Popular Electronics, 5/93, p. 70. (C) Copyright Gernsback Publications, Inc., 1993.
- Fig. 33-8. Reprinted with permission from Popular Electronics, 5/93, p. 72. (C) Copyright Gernsback Publications, Inc., 1993.
- Fig. 33-9. Reprinted with permission from Popular Electronics, 2/94, p. 25. (C) Copyright Gernsback Publications, Inc., 1994.

Chapter 34

- Fig. 34-1. Reprinted with permission of National Semiconductor Corporation, National Semiconductor Linear Applications Handbook, 1991, p. 241.
- Fig. 34-2. Reprinted with permission of National Semiconductor Corporation, National Semiconductor Linear Applications Handbook, 1991, p. 241.

Chapter 35

- Fig. 35-1. Reprinted with permission from Electronic Design, 2/94, p. 115. Copyright 1994, Penton Publishing, Inc.
- Fig. 35-2. Analog Devices, The Best of Analog Dialogue, 1967-1991, p. 75.

Chapter 36

- Fig. 36-1. Reprinted with permission from Electronics Now, 4/94, pp. 41-45. (C) Copyright Gernsback Publications, Inc., 1994.
- Fig. 36-2. Reprinted with permission from Electronics Now, 5/95, pp. 53-55. (C) Copyright Gernsback Publications, Inc., 1995.
- Fig. 36-3. Reprinted with permission from Popular Electronics, Fact Card No. 249. (C) Copyright Gernsback Publications, Inc.
- Fig. 36-4. Reprinted with permission from Electronic Design, 10/94, p. 110. Copyright 1994, Penton Publishing, Inc.

Fig. 36-5. Reprinted with permission of National Semiconductor Corporation, National Semiconductor Linear Applications Handbook, 1991, p. 368.

Chapter 37

Fig. 37-1. Reprinted with permission from Popular Electronics, 9/94, p. 81. (C) Copyright Gernsback Publications, Inc., 1994.

Fig. 37-2. Reprinted with permission from Popular Electronics, 9/94, p. 83. (C) Copyright Gernsback Publications, Inc., 1994.

Fig. 37-3. Reprinted with permission from Popular Electronics, 4/94, p. 79. (C) Copyright Gernsback Publications, Inc., 1994.

Fig. 37-4. Reprinted with permission from Popular Electronics, 12/94, pp. 44-47. (C) Copyright Gernsback Publications, Inc., 1994.

Fig. 37-5. Reprinted with permission from Popular Electronics, 4/94, p. 80. (C) Copyright Gernsback Publications, Inc., 1994.

Fig. 37-6. Reprinted with permission from Popular Electronics, 9/94, p. 81. (C) Copyright Gernsback Publications, Inc., 1994.

Fig. 37-7. Reprinted with permission from Popular Electronics, 9/94, pp. 83 and 92. (C) Copyright Gernsback Publications, Inc., 1994.

Fig. 37-8. Reprinted with permission from Popular Electronics, 5/93, p. 62. (C) Copyright Gernsback Publications, Inc., 1993.

Fig. 37-9. Reprinted with permission from Popular Electronics, 4/94, p. 78. (C) Copyright Gernsback Publications, Inc., 1994.

Fig. 37-10. Reprinted with permission from Popular Electronics, 4/94, p. 78. (C) Copyright Gernsback Publications, Inc., 1994.

Fig. 37-11. Reprinted with permission from

Popular Electronics Hobbyist Handbook, 1991, p. 4. (C) Copyright Gernsback Publications, Inc., 1991.

Chapter 38

Fig. 38-1. Reprinted with permission from 1987 Radio-Electronics Experimenters Handbook, p. 63. (C) Copyright Gernsback Publications, Inc., 1987.

Fig. 38-2. Reprinted with permission from Popular Electronics, 1/94, p. 62. (C) Copyright Gernsback Publications, Inc., 1994.

Chapter 39

Fig. 39-1. Reprinted with permission from Popular Electronics, 6/93, p. 74. (C) Copyright Gernsback Publications, Inc., 1993.

Fig. 39-2. William Sheets.

Fig. 39-3. Analog Devices, Analog Dialogue, Vol. 27, No. 1 (1993), p. 21.

Chapter 40

Fig. 40-1. Reprinted with permission from Popular Electronics, 4/90, p. 102. (C) Copyright Gernsback Publications, Inc., 1990.

Fig. 40-2. Reprinted with permission from Popular Electronics, 6/95, p. 76. (C) Copyright Gernsback Publications, Inc., 1995.

Fig. 40-3. Reprinted with permission from Popular Electronics, 12/93, p. 31. (C) Copyright Gernsback Publications, Inc., 1993.

Fig. 40-4. Reprinted with permission from Popular Electronics, 5/94, p. 69. (C) Copyright Gernsback Publications, Inc., 1994.

Fig. 40-5. Reprinted with permission from Popular Electronics, 4/90, p. 90. (C) Copyright Gernsback Publications, Inc., 1990.

Fig. 40-6. Reprinted with permission from Popular Electronics, 4/94, p. 34. (C)

Copyright Gernsback Publications, Inc., 1994.

Fig. 40-7. Maxim, Vol. III, New Releases Data Book, 1994, p. 3-100.

Fig. 40-8. Reprinted with permission from Electronics Now, 2/94, p. 38. (C) Copyright Gernsback Publications, Inc., 1994.

Fig. 40-9. Reprinted with permission from Popular Electronics, 6/95, p. 76. (C) Copyright Gernsback Publications, Inc., 1995.

Fig. 40-10. Sound Light and Music, Delton T. Horn, McGraw-Hill, pp. 140-142.

Fig. 40-11. Reprinted with permission from Popular Electronics, 4/90, p. 103. (C) Copyright Gernsback Publications, Inc., 1990.

Fig. 40-12. Sound Light and Music, Delton T. Horn, McGraw-Hill, pp. 144-146.

Fig. 40-13. Reprinted with permission from Popular Electronics, 12/93, p. 32. (C) Copyright Gernsback Publications, Inc., 1993.

Fig. 40-14. Laser Cookbook, McGraw-Hill, p. 187.

Fig. 40-15. Reprinted with permission from Popular Electronics, 4/90, p. 91. (C) Copyright Gernsback Publications, Inc., 1990.

Fig. 40-16. Sound Light and Music, McGraw-Hill.

Fig. 40-17. Reprinted with permission of National Semiconductor Corporation, National Semiconductor Linear Applications Handbook, 1991, p. 209.

Chapter 41

Fig. 41-1.

Fig. 41-2. Linear Technology, 2/95.

Fig. 41-3. Reprinted with permission from Popular Electronics, Fact Card No. 248. (C) Copyright Gernsback Publications, Inc.

Fig. 41-4. Analog Devices, Analog Dialogue, Vol. 27, No. 2 (1993), p. 17.

Fig. 41-5. Reprinted with permission from Popular Electronics, Fact Card No. 248. (C) Copyright Gernsback Publications, Inc.

Fig. 41-6. Reprinted with permission from Popular Electronics, Fact Card No. 247. (C) Copyright Gernsback Publications, Inc.

Fig. 41-7. Reprinted with permission of Burr-Brown Corporation, Burr-Brown Data Sheet INA118, (C) 1989-1995 Burr-Brown Corporation.

Fig. 41-8. Maxim, Vol. III, New Releases Data Book, 1994, p. 3-33.

Fig. 41-9. Maxim, Vol. III, New Releases Data Book, 1994, p. 3-69.

Fig. 41-10. Analog Devices, Analog Dialogue, Vol. 27, No. 1 (1993), p. 20.

Fig. 41-11. Linear Technology, 2/95.

Chapter 42

Fig. 42-1. Reprinted with permission from Popular Electronics, Fact Card No. 247. (C) Copyright Gernsback Publications, Inc.

Fig. 42-2. Reprinted with permission from Popular Electronics, Fact Card No. 249. (C) Copyright Gernsback Publications, Inc.

Fig. 42-3. William Sheets.

Chapter 43

Fig. 43-1. Reprinted with permission from Popular Electronics, 4/90, p. 78. (C) Copyright Gernsback Publications, Inc., 1990.

Fig. 43-2. Analog Devices, The Best of Analog Dialogue, 1967-1991, p. 75.

Chapter 44

Fig. 44-1. Power Supplies, Switching Regulators, Inverters, and Converters, McGraw-Hill, pp. 173-174.

Fig. 44-2. Power Supplies, Switching Regulators, Inverters, and Converters, McGraw-Hill, p. 126.

Fig. 44-3. Power Supplies, Switching Regulators, Inverters, and Converters, McGraw-Hill, p. 128.

Fig. 44-4. Maxim, Vol. III, New Releases Data Book, 1994, p. 4-92.

Fig. 44-5. Power Supplies, Switching Regulators, Inverters, and Converters, McGraw-Hill, pp. 152-153.

Chapter 45

- Fig. 45-1. *Fantastic Electronics*, McGraw-Hill, pp. 36–38.
- Fig. 45-2. *73 Amateur Radio Today*, 7/82, p. 53.
- Fig. 45-3. *73 Amateur Radio Today*, 7/82, p. 53.
- Fig. 45-4. *Spring 1994 Electronic Hobbyists Handbook*.

Chapter 46

- Fig. 46-1. *Laser Cookbook*, McGraw-Hill, pp. 165–167.
- Fig. 46-2. *Laser Cookbook*, McGraw-Hill, pp. 157–158.
- Fig. 46-3. *Gordon McComb's Gadgeteer's Goldmine*, McGraw-Hill, p. 125.
- Fig. 46-4. *Laser Cookbook*, McGraw-Hill, p. 201.
- Fig. 46-5. *Laser Cookbook*, McGraw-Hill, p. 190.
- Fig. 46-6. *Laser Cookbook*, McGraw-Hill, p. 200.
- Fig. 46-7. *Laser Cookbook*, McGraw-Hill, p. 170.
- Fig. 46-8. Reprinted with permission from *Popular Electronics*, 6/93, p. 78. (C) Copyright Gernsback Publications, Inc., 1993.
- Fig. 46-9. *Laser Cookbook*, McGraw-Hill, p. 169.
- Fig. 46-10. *Laser Cookbook*, McGraw-Hill, p. 168.

Chapter 47

- Fig. 47-1. Reprinted with permission from *Electronics Now*, 5/94, p. 12. (C) Copyright Gernsback Publications, Inc., 1994.
- Fig. 47-2. William Sheets.
- Fig. 47-3. Reprinted with permission from *Popular Electronics*, 6/95, p. 54. (C) Copyright Gernsback Publications, Inc., 1995.
- Fig. 47-4. *Laser Cookbook*, McGraw-Hill, pp. 140–141.
- Fig. 47-5. *Linear Technology*, 2/95.
- Fig. 47-6. Reprinted with permission from *Electronic Design*, 12/93, p. 75. Copyright 1993, Penton Publishing, Inc.

- Fig. 47-7. Reprinted with permission from *Popular Electronics*, 9/94, p. 24. (C) Copyright Gernsback Publications, Inc., 1994.
- Fig. 47-8. Reprinted with permission from *Electronic Design*, 10/94, p. 92. Copyright 1994, Penton Publishing, Inc.
- Fig. 47-9. Reprinted with permission from *Popular Electronics*, 4/90, p. 77. (C) Copyright Gernsback Publications, Inc., 1990.
- Fig. 47-10. Reprinted with permission from *Popular Electronics*, 9/94, p. 83. (C) Copyright Gernsback Publications, Inc., 1994.
- Fig. 47-11. *Amplifiers, Waveform Generators & Other Low-Cost IC Projects*, McGraw-Hill, pp. 82–83.
- Fig. 47-12. Reprinted with permission from *Electronics Now*, 5/94, p. 45. (C) Copyright Gernsback Publications, Inc., 1994.
- Fig. 47-13. Reprinted with permission from *Popular Electronics*, 1995, p. 77. (C) Copyright Gernsback Publications, Inc., 1995.
- Fig. 47-14. Reprinted with permission of National Semiconductor Corporation, *National Semiconductor Linear Applications Handbook*, 1991, pp. 589–590.
- Fig. 47-15. *Gordon McComb's Gadgeteer's Goldmine*, McGraw-Hill, p. 218.
- Fig. 47-16. *Gordon McComb's Gadgeteer's Goldmine*, McGraw-Hill, p. 219.
- Fig. 47-17. *Spring 1994 Electronics Hobbyist Handbook*.
- Fig. 47-18. *Spring 1994 Electronics Hobbyist Handbook*.
- Fig. 47-19. Reprinted with permission of National Semiconductor Corporation, *National Semiconductor Linear Applications Handbook*, 1991, p. 493.
- Fig. 47-20. Reprinted with permission from *Popular Electronics*, 6/95, p. 56. (C) Copyright Gernsback Publications, Inc., 1995.
- Fig. 47-21. Reprinted with permission from *Electronics Now*, 9/94, p. 66. (C) Copyright Gernsback Publications, Inc., 1994.

Chapter 48

- Fig. 48-1. NASA Tech Briefs, Spring 1977.
Fig. 48-2. Reprinted with permission from Electronic Design, 12/93, p. 73. Copyright 1993, Penton Publishing, Inc.
Fig. 48-3. Reprinted with permission from Popular Electronics, Fact Card No. 268. (C) Copyright Gernsback Publications, Inc.
Fig. 48-4. William Sheets.
Fig. 48-5. William Sheets.

Chapter 49

- Fig. 49-1. Reprinted with permission of National Semiconductor Corporation, National Semiconductor Linear Applications Handbook, 1991, p. 520.
Fig. 49-2. Reprinted with permission of National Semiconductor Corporation, National Semiconductor Linear Applications Handbook, 1991, pp. 519-520.
Fig. 49-3. Reprinted with permission of National Semiconductor Corporation, National Semiconductor Linear Applications Handbook, 1991, p. 519.
Fig. 49-4. Analog Devices, The Best of Analog Dialogue, 1967-1991, p. 78.
Fig. 49-5. Analog Devices, The Best of Analog Dialogue, 1967-1991, p. 79.
Fig. 49-6. Analog Dialogue, Analog Devices, Vol. 26, No. 1, pp. 14-15.
Fig. 49-7. Analog Devices, The Best of Analog Dialogue, 1967-1991, p. 78.
Fig. 49-8. Analog Devices, The Best of Analog Dialogue, 1967-1991, p. 78.
Fig. 49-9. Reprinted with permission from Electronic Design, 3/95, p. 116. Copyright 1995, Penton Publishing, Inc.
Fig. 49-10. Reprinted with permission of National Semiconductor Corporation, National Semiconductor Linear Applications Handbook, 1991, p. 27.
Fig. 49-11. Analog Devices, The Best of Analog Dialogue, 1967-1991, p. 77.

Chapter 50

- Fig. 50-1. Reprinted with permission from Popular Electronics, 4/95, p. 54. (C) Copyright Gernsback Publications, Inc., 1995.

- Fig. 50-2. 1994 Electronic Experimenters Handbook, p. 89.
Fig. 50-3. 73 Amateur Radio Today, 7/93, p. 34.
Fig. 50-4. NASA Tech Briefs, November 1993, p. 56.
Fig. 50-5. Reprinted with permission of National Semiconductor Corporation, National Semiconductor Linear Applications Handbook, 1991, p. 588.
Fig. 50-6. Reprinted with permission of National Semiconductor Corporation, National Semiconductor Linear Applications Handbook, pp. 519-520.
Fig. 50-7. Reprinted with permission from Electronics Now, 3/95, p. 42. (C) Copyright Gernsback Publications, Inc., 1995.
Fig. 50-8. Reprinted with permission from Radio-Electronics, February 1989, p. 64. (C) Copyright Gernsback Publications, Inc., 1989.
Fig. 50-9. Reprinted with permission from Electronics Now, 5/95, p. 10. (C) Copyright Gernsback Publications, Inc., 1995.
Fig. 50-10. Reprinted with permission from Electronics Now, 5/95, p. 10. (C) Copyright Gernsback Publications, Inc., 1995.
Fig. 50-11. Reprinted with permission from Popular Electronics, Fact Card No. 221. (C) Copyright Gernsback Publications, Inc.
Fig. 50-12. Fantastic Electronics, McGraw-Hill, pp. 52-60.
Fig. 50-13. Analog Devices, Analog Dialogue, Vol. 27, No. 2, p. 20.
Fig. 50-14. Electronics Now, 9/94, pp. 73-74.
Fig. 50-15. Reprinted with permission from Popular Electronics, 1/94, pp. 31-36. (C) Copyright Gernsback Publications, Inc., 1994.
Fig. 50-16. Electronics Design, June 27, 1994, p. 33.
Fig. 50-17. Reprinted with permission from Popular Electronics, 10/94, p. 90. (C) Copyright Gernsback Publications, Inc., 1994.
Fig. 50-18. Reprinted with permission from Popular Electronics, 11/94, p. 62. (C) Copyright Gernsback Publications, Inc., 1994.

- Fig. 50-19. Radio-Electronics, Feb. 1989, p. 64.
- Fig. 50-20. Reprinted with permission from Popular Electronics, 11/94, p. 91. (C) Copyright Gernsback Publications, Inc., 1994.
- Fig. 50-21. Reprinted with permission from Electronic Design, 10/94, pp. 102–104. Copyright 1994, Penton Publishing, Inc.
- Fig. 50-22. Reprinted with permission from Electronic Design, 12/94, p. 132. Copyright 1994, Penton Publishing, Inc.
- Fig. 50-23. Reprinted with permission from Electronics Now, 3/95, p. 63. (C) Copyright Gernsback Publications, Inc., 1995.
- Fig. 50-24. Reprinted with permission from Popular Electronics, 5/95, pp. 47–48. (C) Copyright Gernsback Publications, Inc., 1995.
- Fig. 50-25. Reprinted with permission from Popular Electronics, 5/95, pp. 47–48. (C) Copyright Gernsback Publications, Inc., 1995.
- Fig. 50-26. Reprinted with permission from Popular Electronics, 11/94, p. 38. (C) Copyright Gernsback Publications, Inc., 1994.
- Fig. 50-27. Reprinted with permission from Electronic Design, 10/94, pp. 92–94. Copyright 1994, Penton Publishing, Inc.
- Fig. 50-28. RF Design, August 1994, p. 78.
- Fig. 50-29. Reprinted with permission of National Semiconductor Corporation, National Semiconductor Linear Applications Handbook, 1991, p. 206.
- Fig. 50-30. Reprinted with permission of National Semiconductor Corporation, National Semiconductor Linear Applications Handbook, 1991, p. 500.
- Fig. 50-31. Reprinted with permission from Electronic Design, 11/94, pp. 116–118. Copyright 1994, Penton Publishing, Inc.
- Fig. 50-32. Reprinted with permission from Electronic Design, 10/94, pp. 107. Copyright 1994, Penton Publishing, Inc.
- Fig. 50-33. QST, 12/94, p. 27.
- Fig. 50-34. Reprinted with permission from Electronic Design, 8/94, pp. 109. Copyright 1994, Penton Publishing, Inc.
- Fig. 50-35. Reprinted with permission of Burr-Brown Corporation, Burr-Brown Data Sheet INA118, (C) 1989–1995 Burr-Brown Corporation.
- Fig. 50-36. William Sheets.
- Fig. 50-37. Linear Technology, Design Note 96.
- Fig. 50-38. Reprinted with permission from Popular Electronics, 11/94, p. 31. (C) Copyright Gernsback Publications, Inc., 1994.
- Fig. 50-39. Reprinted with permission of XICOR, XICOR Data Sheet, p. 7. (C) Copyright XICOR, Inc.
- Fig. 50-40. Reprinted with permission from Popular Electronics, Fact Card No. 221. (C) Copyright Gernsback Publications, Inc.
- Fig. 50-41. Reprinted with permission from Popular Electronics, 11/94, p. 30. (C) Copyright Gernsback Publications, Inc., 1994.
- Fig. 50-42. William Sheets.
- Fig. 50-43. QST, 10/94, P. 75.
- Fig. 50-44. Reprinted with permission from Popular Electronics, 5/95, p. 69. (C) Copyright Gernsback Publications, Inc., 1995.
- Fig. 50-45. Reprinted with permission from Popular Electronics, 11/94, p. 33. (C) Copyright Gernsback Publications, Inc., 1994.
- Fig. 50-46. Reprinted with permission from Radio-Electronics, February 1989, pp. 63–65. (C) Copyright Gernsback Publications, Inc., 1989.
- Fig. 50-47. Amplifiers, Waveform Generators & Other Low-Cost IC Projects, McGraw-Hill, p. 45.
- Fig. 50-48. Amplifiers, Waveform Generators & Other Low-Cost IC Projects, McGraw-Hill, pp. 40–41.

Chapter 51

- Fig. 51-1. Sound Light and Music, Delton T. Horn, McGraw-Hill, p. 123.
- Fig. 51-2. Sound Light and Music, Delton T. Horn, McGraw-Hill, p. 120.

Chapter 52

- Fig. 52-1. Reprinted with permission from *Electronic Design*, 5/94, pp. 79–80. Copyright 1994, Penton Publishing, Inc.
- Fig. 52-2. Reprinted with permission from *Popular Electronics*, 1/94, p. 26. (C) Copyright Gernsback Publications, Inc., 1994.
- Fig. 52-3. *Analog Devices*, *Analog Dialogue*, Vol. 26, No. 1, 1992, p. 15.
- Fig. 52-4. Reprinted with permission from *Popular Electronics*, 8/89, pp. 33–35. (C) Copyright Gernsback Publications, Inc., 1989.
- Fig. 52-5. *NASA Tech Briefs*, March 1995, pp. 39–40.
- Fig. 52-6. Reprinted with permission from *Radio-Electronics Experimenters Handbook*, pp. 98–99. (C) Copyright Gernsback Publications, Inc., 1994.
- Fig. 52-7. Reprinted with permission from *Radio-Electronics Experimenters Handbook*, p. 99. (C) Copyright Gernsback Publications, Inc., 1994.
- Fig. 52-8. *1994 Electronics Experimenters Handbook*, p. 57.
- Fig. 52-9. *Power Supplies, Switching Regulators, Inverters, and Converters*, McGraw-Hill, pp. 119–123.
- Fig. 52-10. *Amplifiers, Waveform Generators & Other Low-Cost IC Projects*, McGraw-Hill, pp. 121–122.
- Fig. 52-11. Reprinted with permission from *Radio-Electronics Experimenters Handbook*, pp. 36–38. (C) Copyright Gernsback Publications, Inc., 1994.
- Fig. 52-12. Reprinted with permission from *Popular Electronics*, 4/95, p. 70. (C) Copyright Gernsback Publications, Inc., 1995.
- Fig. 52-13. Reprinted with permission from *Popular Electronics*, 4/90, p. 37. (C) Copyright Gernsback Publications, Inc., 1990.
- Fig. 52-14. *Power Supplies, Switching Regulators, Inverters, and Converters*, McGraw-Hill, pp. 175–177.
- Fig. 52-15. *Linear Technology*, *Design Note* 88.
- Fig. 52-16. *Fantastic Electronics*, McGraw-Hill, p. 59.
- Fig. 52-17. *73 Amateur Radio Today*, 6/83, p. 99.
- Fig. 52-18. *Spring 1994 Electronic Hobbyists Handbook*.
- Fig. 52-19. Reprinted with permission from *Electronic Design*, 1/95, p. 78. Copyright 1995, Penton Publishing, Inc.
- Fig. 52-20. *Sound Light and Music*, Delton T. Horn, McGraw-Hill, p. 123.
- Fig. 52-21. *Power Supplies, Switching Regulators, Inverters, and Converters*, McGraw-Hill, pp. 140–145.
- Fig. 52-22. Reprinted with permission from *Electronic Design*, 3/95, pp. 111–112. Copyright 1995, Penton Publishing, Inc.
- Fig. 52-23. Reprinted with permission from *Electronic Design*, 3/95, p. 94. Copyright 1995, Penton Publishing, Inc.
- Fig. 52-24. Reprinted with permission from *Electronic Design*, 4/89, p. 107. Copyright 1989, Penton Publishing, Inc.
- Fig. 52-25. Reprinted with permission of *National Semiconductor Corporation*, *National Semiconductor Linear Applications Handbook*, 1991, p. 367.
- Fig. 52-26. *73 Amateur Radio Today*, 6/83, p. 99.
- Fig. 52-27. Reprinted with permission from *Popular Electronics*, 4/94, p. 52. (C) Copyright Gernsback Publications, Inc., 1994.
- Fig. 52-28. Reprinted with permission from *Electronics Now*, 2/94, p. 16. (C) Copyright Gernsback Publications, Inc., 1994.
- Fig. 52-29. Reprinted with permission from *Electronic Design*, 3/95, p. 91. Copyright 1995, Penton Publishing, Inc.
- Fig. 52-30. William Sheets.
- Fig. 52-31. William Sheets.
- Fig. 52-32. Reprinted with permission from *Electronic Design*, 7/94, p. 96. Copyright 1994, Penton Publishing, Inc.
- Fig. 52-33. Reprinted with permission from *Electronics Now*, 4/94, p. 11. (C) Copyright Gernsback Publications, Inc., 1994.
- Fig. 52-34. Reprinted with permission from *Popular Electronics*, 5/95, p. 30. (C)

Copyright Gernsback Publications, Inc., 1994.

Fig. 52-35. Reprinted with permission from Electronic Design, 12/94, pp. 115–116. Copyright 1994, Penton Publishing, Inc.

Chapter 53

Fig. 53-1. William Sheets.

Fig. 53-2. William Sheets.

Chapter 54

Fig. 54-1. Reprinted with permission from Popular Electronics, 10/94, p. 28. (C) Copyright Gernsback Publications, Inc., 1994.

Fig. 54-2. Reprinted with permission from Popular Electronics, 10/94, p. 26. (C) Copyright Gernsback Publications, Inc., 1994.

Chapter 55

Fig. 55-1. Reprinted with permission from Electronic Design, 10/94, pp. 94–96. Copyright 1994, Penton Publishing, Inc.

Fig. 55-2. Reprinted with permission of National Semiconductor Corporation, National Semiconductor Linear Applications Handbook, 1991, p. 1033.

Fig. 55-3. NASA Tech Briefs, January 1995, pp. 28–29.

Fig. 55-4. Linear Technology, 2/95.

Fig. 55-5. Reprinted with permission from Popular Electronics, Fact Card No. 249. (C) Copyright Gernsback Publications, Inc.

Fig. 55-6. Analog Devices, The Best of Analog Dialogue, 1967–1991, p. 75.

Fig. 55-7. William Sheets.

Chapter 56

Fig. 56-1. 73 Amateur Radio Today, 5/94, p. 12.

Fig. 56-2. 73 Amateur Radio Today, 6/94, pp. 46–48.

Fig. 56-3. Reprinted with permission from Popular Electronics, 5/93, p. 71. (C) Copyright Gernsback Publications, Inc., 1993.

Chapter 57

Fig. 57-1. Power Supplies, Switching Regulators, Inverters, and Converters, McGraw-Hill, pp. 167–169.

Fig. 57-2. Reprinted with permission from Electronic Design, 10/94, pp. 104–105. Copyright 1994, Penton Publishing, Inc.

Fig. 57-3. Gordon McComb's Gadgeteer's Goldmine, McGraw-Hill, p. 355.

Fig. 57-4. Electronics Now, 5/95, p. 8.

Fig. 57-5. Power Supplies, Switching Regulators, Inverters, and Converters, McGraw-Hill, pp. 166–167.

Fig. 57-6. Power Supplies, Switching Regulators, Inverters, and Converters, McGraw-Hill, pp. 163–166.

Fig. 57-7. Gordon McComb's Gadgeteer's Goldmine, McGraw-Hill, p. 48.

Fig. 57-8. Reprinted with permission from Electronics Now, 5/94, p. 10. (C) Copyright Gernsback Publications, Inc., 1994.

Fig. 57-9. Gordon McComb's Gadgeteer's Goldmine, McGraw-Hill, p. 357.

Chapter 58

Fig. 58-1. William Sheets.

Fig. 58-2. Reprinted with permission of National Semiconductor Corporation, National Semiconductor Linear Applications Handbook, 1991, p. 240.

Fig. 58-3. Reprinted with permission from Popular Electronics, 1/94, p. 72. (C) Copyright Gernsback Publications, Inc., 1994.

Fig. 58-4. Reprinted with permission from Popular Electronics, 1/94, p. 73. (C) Copyright Gernsback Publications, Inc., 1994.

Fig. 58-5. Reprinted with permission from Popular Electronics, Fact Card No. 268. (C) Copyright Gernsback Publications, Inc.

Fig. 58-6. Amplifiers, Waveform Generators & Other Low-Cost IC Projects, McGraw-Hill, p. 24.

Fig. 58-7. William Sheets.

Chapter 59

Fig. 59-1. Reprinted with permission of Na-

tional Semiconductor Corporation, National Semiconductor Linear Application Specific IC's Databook 1993, p. 1-38.

Fig. 59-2. Reprinted with permission of National Semiconductor Corporation, National Semiconductor NSLAH 1991, p. 998.

Fig. 59-3. QST, 10/92, p. 22.

Fig. 59-4. William Sheets.

Fig. 59-5. William Sheets.

Chapter 60

Fig. 60-1. Reprinted with permission from Radio-Electronics, June 1987, p. 69. (C) Copyright Gernsback Publications, Inc., 1987.

Fig. 60-2. Reprinted with permission of National Semiconductor Corporation, National Semiconductor Linear Application Handbook, 1991, p. 578.

Fig. 60-3. Reprinted with permission from Radio-Electronics, June 1987, p. 70. (C) Copyright Gernsback Publications, Inc., 1987.

Fig. 60-4. Reprinted with permission from Radio-Electronics, June 1987, p. 75. (C) Copyright Gernsback Publications, Inc., 1987.

Fig. 60-5. Reprinted with permission of National Semiconductor Corporation, National Semiconductor Linear Applications Handbook, 1991, P. 576.

Fig. 60-6. Reprinted with permission from Electronic Design, 12/94, p. 118. Copyright 1994, Penton Publishing, Inc.

Fig. 60-7. Reprinted with permission of National Semiconductor Corporation, National Semiconductor Linear Application Handbook, 1991, p. 1058.

Fig. 60-8. Reprinted with permission from Radio-Electronics, June 1987, p. 75. (C) Copyright Gernsback Publications, Inc., 1987.

Fig. 60-9. Reprinted with permission of National Semiconductor Corporation, National Semiconductor Linear Applications Handbook, 1991, p. 491.

Fig. 60-10. Reprinted with permission of National Semiconductor Corporation,

National Semiconductor Linear Applications Handbook, 1991, p. 578.

Fig. 60-11. Analog Devices, Analog Dialogue, Vol. 27, No. 2 (1993), p. 17.

Chapter 61

Fig. 61-1. Reprinted with permission of National Semiconductor Corporation, National Semiconductor Linear Applications Handbook, p. 1209.

Fig. 61-2. William Sheets.

Fig. 61-3. William Sheets.

Fig. 61-4. Amplifiers, Waveform Generators & Other Low-Cost IC Projects, McGraw-Hill, p. 17.

Fig. 61-5. Reprinted with permission of National Semiconductor Corporation, National Semiconductor Linear Applications Handbook, 1991, P. 1210.

Fig. 61-6. William Sheets.

Fig. 61-7. Reprinted with permission from Popular Electronics, 11/94, p. 31. (C) Copyright Gernsback Publications, Inc., 1994.

Fig. 61-8. William Sheets.

Fig. 61-9. Reprinted with permission from Popular Electronics, 5/93, p. 71. (C) Copyright Gernsback Publications, Inc., 1993.

Fig. 61-10. William Sheets.

Fig. 61-11. Reprinted with permission from Popular Electronics, 3/94, p. 83. (C) Copyright Gernsback Publications, Inc., 1994.

Fig. 61-12. Reprinted with permission from Popular Electronics, 12/93, p. 71. (C) Copyright Gernsback Publications, Inc., 1993.

Chapter 62

Fig. 62-1. Reprinted with permission from Popular Electronics, 12/93, p. 70. (C) Copyright Gernsback Publications, Inc., 1993.

Fig. 62-2. Reprinted with permission from Popular Electronics, 12/93, p. 68. (C) Copyright Gernsback Publications, Inc., 1993.

Fig. 62-3. Reprinted with permission from

- Popular Electronics, 12/93, p. 71. (C) Copyright Gernsback Publications, Inc., 1993.
- Fig. 62-4. Reprinted with permission from Popular Electronics, 12/93, p. 70. (C) Copyright Gernsback Publications, Inc., 1993.
- Fig. 62-5. Reprinted with permission from Electronic Design, 11/94, pp. 130–132. Copyright 1994, Penton Publishing, Inc.
- Fig. 62-6. Analog Devices, The Best of Analog Dialogue, 1967–1991, p. 79.
- Fig. 62-7. Amplifiers, Waveform Generators & Other Low-Cost IC Projects, McGraw-Hill, p. 116.
- Fig. 62-8. Reprinted with permission from Electronics Now, 12/93, p. 16. (C) Copyright Gernsback Publications, Inc., 1993.
- Fig. 62-9. Reprinted with permission from Electronic Design, 7/94, p. 94. Copyright 1994, Penton Publishing, Inc.
- Fig. 62-10. QST, 5/95, p. 50.

Chapter 63

- Fig. 63-1. William Sheets.
- Fig. 63-2. Reprinted with permission from Popular Electronics, 3/94, p. 84. (C) Copyright Gernsback Publications, Inc., 1993.
- Fig. 63-3. William Sheets.
- Fig. 63-4. William Sheets.
- Fig. 63-5. QST, 4/95, pp. 38–39.
- Fig. 63-6. William Sheets.
- Fig. 63-7. Reprinted with permission from Radio-Electronics Experimenters Handbook, p. 75. (C) Copyright Gernsback Publications, Inc., 1994.
- Fig. 63-8. Radio Receiver Projects You Can Build, McGraw-Hill, p. 237.
- Fig. 63-9. William Sheets.
- Fig. 63-10. Reprinted with permission from Popular Electronics, 2/94, p. 90. (C) Copyright Gernsback Publications, Inc., 1994.
- Fig. 63-11. William Sheets.
- Fig. 63-12. Reprinted with permission from Popular Electronics, 11/94, p. 42. (C) Copyright Gernsback Publications, Inc., 1994.

- Fig. 63-13. Reprinted with permission from Popular Electronics, 2/94, p. 90. (C) Copyright Gernsback Publications, Inc., 1994.
- Fig. 63-14. Reprinted with permission from Electronic Design, 10/94, p. 96. Copyright 1994, Penton Publishing, Inc.
- Fig. 63-15. William Sheets.
- Fig. 63-16. 73 Amateur Radio Today, 5/94, p. 66.
- Fig. 63-17. Radio Craft, 1993, p. 63.
- Fig. 63-18. Radio-Electronics Experimenters Handbook, 1992, p. 76.
- Fig. 63-19. William Sheets.
- Fig. 63-20. William Sheets.
- Fig. 63-21. William Sheets.

Chapter 64

- Fig. 64-1. Reprinted with permission from Electronics Now, 5/95, pp. 65–66. (C) Copyright Gernsback Publications, Inc., 1995.
- Fig. 64-2. Reprinted with permission from Electronic Design, 11/94, pp. 118–120. Copyright 1994, Penton Publishing, Inc.
- Fig. 64-3. Reprinted with permission from Electronic Design, 9/94, p. 84. Copyright 1994, Penton Publishing, Inc.
- Fig. 64-4. 73 Amateur Radio Today, 7/94, p. 39.

Chapter 65

- Fig. 65-1. Power Supplies, Switching Regulators, Inverters, and Converters, McGraw-Hill, pp. 107–108.
- Fig. 65-2. Reprinted with permission from Electronics Now, 5/95, p. 91. (C) Copyright Gernsback Publications, Inc., 1995.
- Fig. 65-3. 1994 Electronics Experimenters Handbook, p. 67.

Chapter 66

- Fig. 66-1. Reprinted with permission from Popular Electronics, 3/94, p. 70. (C) Copyright Gernsback Publications, Inc., 1994.
- Fig. 66-2. Gordon McComb's Gadgeteer's Goldmine, McGraw-Hill, p. 94.

Chapter 67

- Fig. 67-1. Reprinted with permission from Electronics Now, 5/95, pp. 67-68. (C) Copyright Gernsback Publications, Inc., 1995.
- Fig. 67-2. Reprinted with permission from Popular Electronics, 10/94, p. 84. (C) Copyright Gernsback Publications, Inc., 1994.
- Fig. 67-3. Reprinted with permission from Electronics Now, 3/94, p. 59. (C) Copyright Gernsback Publications, Inc., 1994.
- Fig. 67-4. Reprinted with permission from Popular Electronics, 12/94, pp. 57-59. (C) Copyright Gernsback Publications, Inc., 1994.

Chapter 68

- Fig. 68-1. Reprinted with permission from Popular Electronics, 4/95, p. 60. (C) Copyright Gernsback Publications, Inc., 1995.
- Fig. 68-2. Reprinted with permission from Popular Electronics, 4/95, p. 60. (C) Copyright Gernsback Publications, Inc., 1995.
- Fig. 68-3. Reprinted with permission from Electronic Design, 11/94, p. 133. Copyright 1994, Penton Publishing, Inc.
- Fig. 68-4. Reprinted with permission from Popular Electronics, 4/90, pp. 45-46. (C) Copyright Gernsback Publications, Inc., 1990.
- Fig. 68-5. Maxim, Vol. III, New Releases Data Book, 1994, p. 4-131.
- Fig. 68-6. Power Supplies, Switching Regulators, Inverters, and Converters, McGraw-Hill, p. 133.
- Fig. 68-7. Linear Technology, Design Note #87.
- Fig. 68-8. 1994 Electronics Experimenters Handbook, p. 39.
- Fig. 68-9. Reprinted with permission of National Semiconductor Corporation, National Semiconductor Linear Applications Handbook, 1991, p. 449.
- Fig. 68-10. Linear Technology, Design Note #74.
- Fig. 68-11. Reprinted with permission from Radio-Electronics Experimenters Handbook 1992, p. 74. (C) Copyright Gernsback Publications, Inc., 1992.
- Fig. 68-12. William Sheets.
- Fig. 68-13. Reprinted with permission of National Semiconductor Corporation, National Semiconductor Linear Applications Handbook, 1991, p. 30.
- Fig. 68-14. Reprinted with permission from Electronic Design, 7/94, p. 34. Copyright 1994, Penton Publishing, Inc.
- Fig. 68-15. Reprinted with permission from Electronic Design, 6/94, p. 32. Copyright 1994, Penton Publishing, Inc.
- Fig. 68-16. Power Supplies, Switching Regulators, Inverters, and Converters, McGraw-Hill, pp. 161-163.
- Fig. 68-17. NASA Tech Briefs, August 1994, p. 39.
- Fig. 68-18. Linear Technology, Design Note #87.
- Fig. 68-19. Reprinted with permission of National Semiconductor Corporation, National Semiconductor Linear Applications Handbook, 1991, p. 367.
- Fig. 68-20. Reprinted with permission from Electronic Design, 12/94, p. 130. Copyright 1994, Penton Publishing, Inc.
- Fig. 68-21. Reprinted with permission from Electronic Design, 10/94, pp. 108-110. Copyright 1994, Penton Publishing, Inc.
- Fig. 68-22. Reprinted with permission of National Semiconductor Corporation, National Semiconductor Linear Applications Handbook, 1991, p. 1063.
- Fig. 68-23. Reprinted with permission from Popular Electronics, 6/95, p. 78. (C) Copyright Gernsback Publications, Inc., 1995.
- Fig. 68-24. Linear Technology, Design Note #74.
- Fig. 68-25. Reprinted with permission from Electronic Design, 9/94, p. 140. Copyright 1994, Penton Publishing, Inc.
- Fig. 68-26. Reprinted with permission of National Semiconductor Corporation, National Semiconductor Linear Applications Handbook, 1991, p. 1063.
- Fig. 68-27. Reprinted with permission from

Electronic Design, 7/94, p. 30. Copyright 1994, Penton Publishing, Inc.

- Fig. 68-28. Reprinted with permission of National Semiconductor Corporation, National Semiconductor Linear Applications Handbook, 1991, p. 450.
- Fig. 68-29. William Sheets.
- Fig. 68-30. Maxim, Vol. III, New Releases Data Book, 1994, p. 4-131.
- Fig. 68-31. Laser Cookbook, McGraw-Hill, p. 172.
- Fig. 68-32. Analog Devices, Analog Dialogue, Vol. 27, No. 2, p. 19.
- Fig. 68-33. Reprinted with permission of National Semiconductor Corporation, National Semiconductor Linear Applications Handbook, 1991, p. 450.
- Fig. 68-34. Laser Cookbook, McGraw-Hill, p. 172.
- Fig. 68-35. Reprinted with permission from Popular Electronics, 5/95, p. 94. (C) Copyright Gernsback Publications, Inc., 1995.
- Fig. 68-36. 73 Amateur Radio Today, 5/93, p. 51.
- Fig. 68-37. Reprinted with permission from Electronics Now, 12/93, p. 14. (C) Copyright Gernsback Publications, Inc., 1993.

Chapter 69

- Fig. 69-1. Reprinted with permission from Popular Electronics, 6/93, p. 77. (C) Copyright Gernsback Publications, Inc., 1993.
- Fig. 69-2. Reprinted with permission of National Semiconductor Corporation, National Semiconductor Linear Applications Handbook, 1991, p. 351.
- Fig. 69-3. Reprinted with permission from Electronics Now, 10/94, pp. 58-61. (C) Copyright Gernsback Publications, Inc., 1994.
- Fig. 69-4. William Sheets.
- Fig. 69-5. Reprinted with permission from Popular Electronics, 6/93, p. 77. (C) Copyright Gernsback Publications, Inc., 1993.
- Fig. 69-6. Laser Cookbook, McGraw-Hill, p. 163.

- Fig. 69-7. Reprinted with permission of National Semiconductor Corporation, National Semiconductor Linear Applications Handbook, 1991, p. 498.
- Fig. 69-8. Fantastic Electronics, McGraw-Hill, p. 177.
- Fig. 69-9. Gordon McComb's Gadgeteer's Goldmine, p. 269.
- Fig. 69-10. Reprinted with permission of National Semiconductor Corporation, National Semiconductor Linear Applications Handbook, 1991, p. 497.
- Fig. 69-11. Laser Cookbook, McGraw-Hill, pp. 160-161.

Chapter 70

- Fig. 70-1. 73 Amateur Radio Today, 5/93, p. 32.
- Fig. 70-2. Laser Cookbook, McGraw-Hill, p. 172.
- Fig. 70-3. Reprinted with permission from Electronic Design, 5/90, p. 80. Copyright 1990, Penton Publishing, Inc.
- Fig. 70-4. Linear Technology, Design Note #99.
- Fig. 70-5. Radio Receiver Projects You Can Build, McGraw-Hill 4256, p. 241.
- Fig. 70-6. Reprinted with permission from Popular Electronics, 11/94, p. 41. (C) Copyright Gernsback Publications, Inc., 1994.
- Fig. 70-7. Linear Technology, Design Note #78.
- Fig. 70-8. Reprinted with permission from Electronics Now, 2/94, p. 83. (C) Copyright Gernsback Publications, Inc., 1994.
- Fig. 70-9. Reprinted with permission from Radio-Electronics, June 1987, p. 75. (C) Copyright Gernsback Publications, Inc., 1987.

Chapter 71

- Fig. 71-1. Reprinted with permission from Popular Electronics, 4/95, p. 96. (C) Copyright Gernsback Publications, Inc., 1995.
- Fig. 71-2. Reprinted with permission from Electronic Design, 6/94, p. 62. Copyright 1994, Penton Publishing, Inc.

Fig. 71-3. QST, 10/92, p. 50.

Fig. 71-4. William Sheets.

Fig. 71-5. Reprinted with permission from Popular Electronics, 4/95, p. 96. (C) Copyright Gernsback Publications, Inc., 1995.

Fig. 71-6. Reprinted with permission of National Semiconductor Corporation, National Semiconductor Linear Applications Handbook, 1991, p. 450.

Fig. 71-7. Reprinted with permission of National Semiconductor Corporation, National Semiconductor Linear Applications Handbook, 1991, p. 495.

Fig. 71-8. William Sheets.

Chapter 72

Fig. 72-1. Reprinted with permission from Electronic Design, 1/95, p. 133. Copyright 1995, Penton Publishing, Inc.

Fig. 72-2. Reprinted with permission from Electronics Now, 3/95, p. 64. (C) Copyright Gernsback Publications, Inc., 1995.

Fig. 72-3. 73 Amateur Radio Today, 6/83, p. 99.

Fig. 72-4. Reprinted with permission from Popular Electronics, 2/94, p. 58. (C) Copyright Gernsback Publications, Inc., 1994.

Fig. 72-5. Analog Devices, Analog Dialogue, Vol. 27, No. 1 (1993), p. 20.

Fig. 72-6. Reprinted with permission from Radio-Electronics Experimenters Handbook, pp. 77-82. (C) Copyright Gernsback Publications, Inc., 1994.

Chapter 73

Fig. 73-1. Reprinted with permission from Popular Electronics, 11/94, pp. 31 and 91. (C) Copyright Gernsback Publications, Inc., 1994.

Fig. 73-2. William Sheets.

Chapter 74

Fig. 74-1. Reprinted with permission from Popular Electronics, 6/95, p. 38. (C) Copyright Gernsback Publications, Inc., 1995.

Fig. 74-2. Reprinted with permission from

Popular Electronics, 6/95, p. 39. (C) Copyright Gernsback Publications, Inc., 1995.

Chapter 75

Fig. 75-1. Fantastic Electronics, McGraw-Hill, pp. 67-73.

Fig. 75-2. Reprinted with permission from Electronics Now, 1/94, p. 61. (C) Copyright Gernsback Publications, Inc., 1994.

Fig. 75-3. Reprinted with permission from Electronics Now, 1/94, p. 61. (C) Copyright Gernsback Publications, Inc., 1994.

Fig. 75-4. Reprinted with permission from Electronics Now, 1/94, p. 59. (C) Copyright Gernsback Publications, Inc., 1994.

Fig. 75-5. Reprinted with permission from Popular Electronics, 5/93, p. 40. (C) Copyright Gernsback Publications, Inc., 1993.

Chapter 76

Fig. 76-1. Reprinted with permission from Popular Electronics, 5/95, p. 66. (C) Copyright Gernsback Publications, Inc., 1995.

Fig. 76-2. Reprinted with permission from Popular Electronics, 1/95, p. 49. (C) Copyright Gernsback Publications, Inc., 1995.

Fig. 76-3. Radio Receiver Projects You Can Build, McGraw-Hill 4256, pp. 122-129.

Fig. 76-4. Radio-Electronics Experimenters Handbook, p. 65.

Fig. 76-5. Reprinted with permission of National Semiconductor Corporation, National Semiconductor Linear Application Specific IC's Databook 1993, p. 2-38.

Fig. 76-6. Radio Craft, 1993, p. 50.

Fig. 76-7. Analog Devices, Analog Dialogue, Vol. 27, No. 1 (1993), pp. 15-16.

Fig. 76-8. Reprinted with permission from Popular Electronics, 3/94, p. 35. (C) Copyright Gernsback Publications, Inc., 1994.

Fig. 76-9. Radio Receiver Projects You Can Build, McGraw-Hill, pp. 158-165.

Fig. 76-10. Radio Receiver Projects You Can Build, McGraw-Hill, pp. 138-147.

- Fig. 76-11. Radio Receiver Projects You Can Build, McGraw-Hill, pp. 102–109.
- Fig. 76-12. Radio Receiver Projects You Can Build, McGraw-Hill, pp. 196–203.
- Fig. 76-13. Radio Receiver Projects You Can Build, McGraw-Hill, pp. 32–41.
- Fig. 76-14. Analog Devices, Analog Dialogue, Vol. 26, No. 2, 1992, p. 19.
- Fig. 76-15. Reprinted with permission from Popular Electronics, 5/94, p. 79. (C) Copyright Gernsback Publications, Inc., 1994.
- Fig. 76-16. Reprinted with permission from Popular Electronics, 10/94, p. 25. (C) Copyright Gernsback Publications, Inc., 1994.
- Fig. 76-17. Reprinted with permission from Electronics Now, 3/94, p. 68. (C) Copyright Gernsback Publications, Inc., 1994.
- Fig. 76-18. Reprinted with permission from Electronics Now, 3/94, p. 67. (C) Copyright Gernsback Publications, Inc., 1994.
- Fig. 76-19. Reprinted with permission from Popular Electronics, 10/94, p. 62. (C) Copyright Gernsback Publications, Inc., 1994.
- Fig. 76-20. Analog Devices, Analog Dialogue, Vol. 27, No. 1 (1993), p. 15.
- Fig. 76-21. Radio Craft, 1993, p. 64.
- Fig. 76-22. William Sheets.
- Fig. 76-23. Reprinted with permission from Electronics Now, 3/94, p. 69. (C) Copyright Gernsback Publications, Inc., 1994.
- Fig. 76-24. Reprinted with permission from Electronics Now, 3/94, p. 69. (C) Copyright Gernsback Publications, Inc., 1994.
- Fig. 76-25. Reprinted with permission from Electronics Now, 3/94, pp. 70–72. (C) Copyright Gernsback Publications, Inc., 1994.
- Fig. 76-26. Reprinted with permission from Popular Electronics, 5/95, pp. 55–56. (C) Copyright Gernsback Publications, Inc., 1995.
- Fig. 76-27. William Sheets.
- Fig. 76-28. Reprinted with permission from Electronics Now, 3/95, p. 50. (C) Copyright Gernsback Publications, Inc., 1994.

Chapter 77

- Fig. 77-1. Reprinted with permission from Electronic Design, 6/94, p. 29. Copyright 1995, Penton Publishing, Inc.
- Fig. 77-2. Reprinted with permission of National Semiconductor Corporation, National Semiconductor Linear Applications Handbook, 1991, p. 26.
- Fig. 77-3. Reprinted with permission of National Semiconductor Corporation, National Semiconductor Linear Applications Handbook, 1991, p. 26.

Chapter 78

- Fig. 78-1. Linear Technology, Design Note #98.
- Fig. 78-2. Reprinted with permission from Electronics Now, 7/94, p. 12. (C) Copyright Gernsback Publications, Inc., 1994.
- Fig. 78-3. Reprinted with permission from Electronic Design, 2/95, p. 118. Copyright 1995, Penton Publishing, Inc.
- Fig. 78-4. Linear Technology, Design Note #100.
- Fig. 78-5. Linear Technology, Design Note #98.
- Fig. 78-6. NASA Tech Briefs, August 1994, p. 38.
- Fig. 78-7. Linear Technology, Advertisement LT/1294.
- Fig. 78-8. Reprinted with permission from Electronic Design, 7/94, p. 32. Copyright 1994, Penton Publishing, Inc.
- Fig. 78-9. Reprinted with permission from Electronic Design, 1/95, pp. 133–134. Copyright 1995, Penton Publishing, Inc.
- Fig. 78-10. Linear Technology, Design Note #98.

Chapter 79

- Fig. 79-1. William Sheets.
- Fig. 79-2. William Sheets.
- Fig. 79-3. William Sheets.
- Fig. 79-4. William Sheets.
- Fig. 79-5. William Sheets.
- Fig. 79-6. William Sheets.
- Fig. 79-7. William Sheets.

Chapter 80

Fig. 80-1. Maxim, Vol. III, New Releases Data Book, 1994, p. 3-30.

Fig. 80-2. Reprinted with permission of National Semiconductor Corporation, National Semiconductor Linear Applications Handbook, 1991, p. 1202.

Chapter 81

Fig. 81-1. Reprinted with permission from Popular Electronics, 11/94, pp. 75-76. (C) Copyright Gernsback Publications, Inc., 1994.

Fig. 81-2. Reprinted with permission from Popular Electronics, 11/94, pp. 74-75. (C) Copyright Gernsback Publications, Inc., 1994.

Chapter 82

Fig. 82-1. Reprinted with permission of National Semiconductor Corporation, National Semiconductor Linear Application Specific IC's Databook 1993, p. 1-37.

Fig. 82-2. Reprinted with permission from Popular Electronics, 9/94, p. 73. (C) Copyright Gernsback Publications, Inc., 1994.

Fig. 82-3. 73 Amateur Radio Today, 4/95, pp. 54-58.

Chapter 83

Fig. 83-1. William Sheets.

Fig. 83-2. William Sheets.

Fig. 83-3. Reprinted with permission from Popular Electronics, 5/93, p. 71. (C) Copyright Gernsback Publications, Inc., 1993.

Fig. 83-4. William Sheets.

Fig. 83-5. Sound Light and Music, Delton T. Horn, McGraw-Hill, pp. 105-106.

Chapter 84

Fig. 84-1. Sound Light and Music, Delton T. Horn, McGraw-Hill, pp. 106-110.

Fig. 84-2. Reprinted with permission from Popular Electronics, 1/94, p. 75. (C) Copyright Gernsback Publications, Inc., 1994.

Fig. 84-3. 1994 Electronic Experimenters Handbook, p. 53.

Fig. 84-4. William Sheets.

Fig. 84-5. Sound Light and Music, Delton T. Horn, McGraw-Hill, pp. 98-100.

Fig. 84-6. Sound Light and Music, Delton T. Horn, McGraw-Hill, pp. 114-115.

Fig. 84-7. Amplifiers, Waveform Generators & Other Low-Cost IC Projects, McGraw-Hill, p. 147.

Fig. 84-8. Gordon McComb's Gadgeteer's Goldmine, McGraw-Hill, p. 127.

Chapter 85

Fig. 85-1. Reprinted with permission from Popular Electronics, Fact Card No. 221. (C) Copyright Gernsback Publications, Inc.

Fig. 85-2. William Sheets.

Chapter 86

Fig. 86-1. Reprinted with permission from Popular Electronics, 11/94, pp. 76 and 91. (C) Copyright Gernsback Publications, Inc., 1994.

Fig. 86-2. William Sheets.

Fig. 86-3. Reprinted with permission of National Semiconductor Corporation, National Semiconductor Linear Applications Handbook, 1991, p. 235.

Fig. 86-4. Reprinted with permission of National Semiconductor Corporation, National Semiconductor Linear Applications Handbook, 1991, p. 236.

Chapter 87

Fig. 87-1. Reprinted with permission from Electronic Design, 7/94, p. 94. Copyright 1994, Penton Publishing, Inc.

Fig. 87-2. Reprinted with permission from Electronics Now, 2/94, p. 55. (C) Copyright Gernsback Publications, Inc., 1994.

Fig. 87-3. Reprinted with permission from Electronics Now, 2/94, p. 57. (C) Copyright Gernsback Publications, Inc., 1994.

Chapter 88

Fig. 88-1. Reprinted with permission from Popular Electronics, 6/93, p. 71. (C)

- Copyright Gernsback Publications, Inc., 1993.
- Fig. 88-2. Analog Devices, The Best of Analog Dialogue, 1967–1991, p. 117.
- Fig. 88-3. Analog Devices, The Best of Analog Dialogue, 1967–1991, p. 117.
- Fig. 88-4. Reprinted with permission from Electronic Design, 7/94, pp. 96–97. Copyright 1994, Penton Publishing, Inc.
- Fig. 88-5. Analog Devices, The Best of Analog Dialogue, 1967–1991, p. 117.
- Fig. 88-6. Reprinted with permission from Popular Electronics, 6/93, p. 71. (C) Copyright Gernsback Publications, Inc., 1993.
- Fig. 88-7. Reprinted with permission from Electronics Now, 5/95, p. 63. (C) Copyright Gernsback Publications, Inc., 1995.
- Fig. 88-8. Reprinted with permission from Electronic Design, 1/94, p. 118. Copyright 1994, Penton Publishing, Inc.
- Fig. 88-9. Reprinted with permission from Popular Electronics, 12/94, p. 41. (C) Copyright Gernsback Publications, Inc., 1994.
- Fig. 88-10. Reprinted with permission from Popular Electronics, 12/94, p. 42. (C) Copyright Gernsback Publications, Inc., 1994.
- Fig. 88-11. Reprinted with permission from Popular Electronics, 12/94, p. 41. (C) Copyright Gernsback Publications, Inc., 1994.
- Fig. 88-12. Amplifiers, Waveform Generators & Other Low-Cost IC Projects, McGraw-Hill, p. 72.
- Fig. 88-13. Reprinted with permission from Popular Electronics, 12/94, p. 41. (C) Copyright Gernsback Publications, Inc., 1994.
- Fig. 88-14. Reprinted with permission from Popular Electronics, 12/94, p. 41. (C) Copyright Gernsback Publications, Inc., 1994.
- Fig. 88-15. Reprinted with permission from Popular Electronics, 12/94, p. 41. (C) Copyright Gernsback Publications, Inc., 1994.
- Fig. 88-16. Maxim, Vol. III, New Releases Data Book, 1994, p. 3-125.
- Fig. 88-17. William Sheets.
- Fig. 88-18. Reprinted with permission from Popular Electronics, 6/93, p. 71. (C) Copyright Gernsback Publications, Inc., 1993.
- Fig. 88-19. William Sheets.
- Fig. 88-20. Reprinted with permission from Popular Electronics, 6/93, p. 72. (C) Copyright Gernsback Publications, Inc., 1993.
- Fig. 88-21. Electronics Now, 8/93, p. 12.
- Fig. 88-22. William Sheets.
- Fig. 88-23. Analog Devices, The Best of Analog Dialogue, 1967–1991, p. 117.

Chapter 89

- Fig. 89-1. Reprinted with permission from Electronic Design, 10/88, pp. 126–128. Copyright 1988, Penton Publishing, Inc.
- Fig. 89-2. Analog Devices, Analog Dialogue, Vol. 26, No. 1, 1992, p. 12.
- Fig. 89-3. Reprinted with permission from Electronic Design, 11/93, p. 99. Copyright 1993, Penton Publishing, Inc.
- Fig. 89-4. Analog Devices, Analog Dialogue, Vol. 26, No. 1, 1992, p. 13.
- Fig. 89-5. Reprinted with permission from Electronic Design, 10/88, p. 128. Copyright 1988, Penton Publishing, Inc.

Chapter 90

- Fig. 90-1. Reprinted with permission from 1987 Radio-Electronics Experimenters Handbook, p. 51. (C) Copyright Gernsback Publications, Inc., 1994.
- Fig. 90-2. Reprinted with permission from Electronics Now, 2/94, p. 33. (C) Copyright Gernsback Publications, Inc., 1994.
- Fig. 90-3. Reprinted with permission from Electronics Now, 10/94, p. 53. (C) Copyright Gernsback Publications, Inc., 1994.
- Fig. 90-4. 1994 Electronics Experimenters Handbook, p. 123.
- Fig. 90-5. Reprinted with permission from Electronics Now, 4/95, pp. 39–40. (C) Copyright Gernsback Publications, Inc., 1995.

- Fig. 90-6. Reprinted with permission from Electronics Now, 8/94, p. 26. (C) Copyright Gernsback Publications, Inc., 1994.
- Fig. 90-7. Analog Devices, The Best of Analog Dialogue, 1967–1991, p. 75.
- Fig. 90-8. Reprinted with permission from Popular Electronics, 12/93, p. 62. (C) Copyright Gernsback Publications, Inc., 1993.
- Fig. 90-9. Gordon McComb's Gadgeteer's Goldmine, McGraw-Hill, pp. 335–336.
- Fig. 90-10. Reprinted with permission from Electronics Now, 2/94, p. 16. (C) Copyright Gernsback Publications, Inc., 1994.
- Fig. 90-11. Reprinted with permission from Electronics Now, 8/93, pp. 58–63. (C) Copyright Gernsback Publications, Inc., 1993.
- Fig. 90-12. Reprinted with permission from Radio-Electronics, August 1993, pp. 58–63. (C) Copyright Gernsback Publications, Inc., 1993.
- Fig. 90-13. Reprinted with permission from Electronic Design, 8/94, p. 116. Copyright 1994, Penton Publishing, Inc.
- Fig. 90-14. William Sheets.

Chapter 91

- Fig. 91-1. 1994 Electronics Experimenters Handbook, p. 63.
- Fig. 91-2. Reprinted with permission from Electronic Design, 7/94, p. 93. Copyright 1994, Penton Publishing, Inc.
- Fig. 91-3. Reprinted with permission from Electronic Design, 11/93, pp. 90–92. Copyright 1993, Penton Publishing, Inc.
- Fig. 91-4. Reprinted with permission from Electronic Design, 1/95, pp. 80–81. Copyright 1995, Penton Publishing, Inc.
- Fig. 91-5. Reprinted with permission from Popular Electronics, 6/95, p. 48. (C) Copyright Gernsback Publications, Inc., 1995.
- Fig. 91-6. Reprinted with permission of National Semiconductor Corporation, National Semiconductor Linear Applications Handbook, 1991, p. 524.
- Fig. 91-7. Reprinted with permission from Electronic Design, 1/94, pp. 118–119. Copyright 1994, Penton Publishing, Inc.
- Fig. 91-8. Reprinted with permission of National Semiconductor Corporation, National Semiconductor Linear Applications Handbook, 1991, p. 524.
- Fig. 91-9. Reprinted with permission of National Semiconductor Corporation, National Semiconductor Linear Applications Handbook, 1991, p. 500.
- Fig. 91-10. Reprinted with permission of National Semiconductor Corporation, National Semiconductor Linear Applications Handbook, 1991, p. 1076.
- Fig. 91-11. Reprinted with permission of National Semiconductor Corporation, National Semiconductor Linear Applications Handbook, 1991, p. 1076.
- Fig. 91-12. Reprinted with permission of National Semiconductor Corporation, National Semiconductor Linear Applications Handbook, 1991, p. 1076.
- Fig. 91-13. Reprinted with permission of National Semiconductor Corporation, National Semiconductor Linear Applications Handbook, 1991, p. 1076.
- Fig. 91-14. Analog Devices, The Best of Analog Dialogue, 1967–1991, p. 75.
- Fig. 91-15. Analog Devices, The Best of Analog Dialogue, 1967–1991, p. 75.
- Fig. 91-16. Reprinted with permission of National Semiconductor Corporation, National Semiconductor, NSLAH 1991, p. 1079.
- Fig. 91-17. Reprinted with permission of National Semiconductor Corporation, National Semiconductor Linear Applications Handbook, 1991, p. 493.
- Fig. 91-18. Reprinted with permission of National Semiconductor Corporation, National Semiconductor Linear Applications Handbook, 1991, p. 1077.
- Fig. 91-19. Reprinted with permission from Popular Electronics, 5/93, p. 43. (C) Copyright Gernsback Publications, Inc., 1993.
- Fig. 91-20. Reprinted with permission of Burr-Brown Corporation, Burr-Brown Data Sheet INA118, (C) 1989–1995 Burr-Brown Corporation.

- Fig. 91-21. Analog Devices, Analog Dialogue, Vol. 27, No. 2, p. 22.
- Fig. 91-22. Reprinted with permission of National Semiconductor Corporation, National Semiconductor Linear Applications Handbook, 1991, p. 1076.
- Fig. 91-23. QST, 5/95, p. 85.
- Fig. 91-24. Reprinted with permission of National Semiconductor Corporation, National Semiconductor Linear Applications Handbook, 1991, p. 523.
- Fig. 91-25. Reprinted with permission from Popular Electronics, 1/95, p. 28. (C) Copyright Gernsback Publications, Inc., 1995.
- Fig. 91-26. QST, 5/95, p. 85.
- Fig. 91-27. Reprinted with permission of National Semiconductor Corporation, National Semiconductor Linear Applications Handbook, 1991, p. 1079.
- Fig. 91-28. Reprinted with permission of National Semiconductor Corporation, National Semiconductor Linear Applications Handbook, 1991, p. 1076.
- Fig. 91-29. Reprinted with permission from Popular Electronics, 1/95, p. 29. (C) Copyright Gernsback Publications, Inc., 1995.
- Fig. 91-30. Power Supplies, Switching Regulators, Inverters, and Converters, McGraw-Hill, pp. 163-164.

Chapter 92

- Fig. 92-1. Reprinted with permission from Popular Electronics, 9/94, p. 26. (C) Copyright Gernsback Publications, Inc., 1994.
- Fig. 92-2. Reprinted with permission from Popular Electronics, 2/94, p. 25. (C) Copyright Gernsback Publications, Inc., 1994.
- Fig. 92-3. Reprinted with permission from Electronic Design, 3/95, pp. 114-116. Copyright 1995, Penton Publishing, Inc.

Chapter 93

- Fig. 93-1. William Sheets.
- Fig. 93-2. William Sheets.
- Fig. 93-3. William Sheets.

- Fig. 93-4. William Sheets.

Chapter 94

- Fig. 94-1. William Sheets.
- Fig. 94-2. Amplifiers, Waveform Generators & Other Low-Cost IC Projects, McGraw-Hill, p. 92.
- Fig. 94-3. NASA Tech Briefs, August 1994, pp. 34-35.
- Fig. 94-4. William Sheets.
- Fig. 94-5. Reprinted with permission from Popular Electronics, Fact Card No. 270. (C) Copyright Gernsback Publications, Inc.

Chapter 95

- Fig. 95-1. Spring 1994 Electronics Hobbyist Handbook.
- Fig. 95-2. Reprinted with permission from Electronics Now, 5/95, p. 8. (C) Copyright Gernsback Publications, Inc., 1995.
- Fig. 95-3. Reprinted with permission from Popular Electronics, Fact Card No. 221. (C) Copyright Gernsback Publications, Inc.

Chapter 96

- Fig. 96-1. Reprinted with permission from Electronics Now, 6/93, pp. 41-46. (C) Copyright Gernsback Publications, Inc., 1993.
- Fig. 96-2. Reprinted with permission from Electronics Now, 12/93, p. 29. (C) Copyright Gernsback Publications, Inc., 1993.
- Fig. 96-3. 1994 Electronics Experimenters Handbook, p. 105.
- Fig. 96-4. Reprinted with permission from Electronics Now, 1994 Experimenters Handbook, p. 77. (C) Copyright Gernsback Publications, Inc., 1994.
- Fig. 96-5. Gordon McComb's Gadgeteer's Goldmine, McGraw-Hill, pp. 340-341.
- Fig. 96-6. 73 Amateur Radio Today, 5/93, p. 56.
- Fig. 96-7. Reprinted with permission from Popular Electronics, 8/92, p. 45. (C) Copyright Gernsback Publications, Inc., 1992.

Chapter 97

- Fig. 97-1. Reprinted with permission from Popular Electronics, 5/95, p. 29. (C) Copyright Gernsback Publications, Inc., 1995.
- Fig. 97-2. Reprinted with permission from Popular Electronics, 1/95, pp. 72-73. (C) Copyright Gernsback Publications, Inc., 1995.
- Fig. 97-3. Reprinted with permission from Popular Electronics, 1/95, p. 71. (C) Copyright Gernsback Publications, Inc., 1995.
- Fig. 97-4. Reprinted with permission from Popular Electronics, 1/95, p. 73. (C) Copyright Gernsback Publications, Inc., 1995.
- Fig. 97-5. Reprinted with permission from Popular Electronics, 12/94, p. 72. (C) Copyright Gernsback Publications, Inc., 1994.
- Fig. 97-6. Reprinted with permission from Popular Electronics, 12/94, pp. 74-75. (C) Copyright Gernsback Publications, Inc., 1994.

Chapter 98

- Fig. 98-1. Reprinted with permission from Electronics Now, 5/95, pp. 50-51. (C) Copyright Gernsback Publications, Inc., 1995.
- Fig. 98-2. Analog Devices, AD8001 Data Sheet.
- Fig. 98-3. Reprinted with permission of National Semiconductor Corporation, National Semiconductor Linear Application Specific IC's Databook 1993, p. 3-50.
- Fig. 98-4. Reprinted with permission of National Semiconductor Corporation, National Semiconductor Linear Application Specific IC's Databook 1993, p. 3-33.
- Fig. 98-5. Reprinted with permission from Radio-Electronics Experimenters Handbook, pp. 83-88, 1994. (C) Copyright Gernsback Publications, Inc., 1994.
- Fig. 98-6. Reprinted with permission of National Semiconductor Corporation, National Semiconductor Linear Applications Handbook, p. 1021.

- Fig. 98-7. Maxim, Vol. III, New Releases Data Book, 1994, p. 8-16.
- Fig. 98-8. 73 Amateur Radio Today, 7/93, p. 74.
- Fig. 98-9. Reprinted with permission of National Semiconductor Corporation, National Semiconductor Linear Application Specific IC's Databook 1993, p. 3-32.
- Fig. 98-10. 73 Amateur Radio Today, 7/93, p. 74.
- Fig. 98-11. Reprinted with permission of National Semiconductor Corporation, National Semiconductor Linear Application Specific IC's Databook 1993, p. 3-13.
- Fig. 98-12. Linear Technology, Design Note #92.
- Fig. 98-13. Maxim, Vol. III, New Releases Data Book, 1994, p. 8-16.
- Fig. 98-14. Reprinted with permission from Popular Electronics, Fact Card No. 268. (C) Copyright Gernsback Publications, Inc.
- Fig. 98-15. Maxim, Vol. III, New Releases Data Book, 1994, p. 8-19.
- Fig. 98-16. Linear Technology, 2/95.
- Fig. 98-17. Analog Dialogue, Analog Devices, Vol. 26, No. 1, 1992, p. 11.

Chapter 99

- Fig. 99-1. Analog Devices, The Best of Analog Dialogue, 1967-1991, p.75.
- Fig. 99-2. Reprinted with permission of National Semiconductor Corporation, National Semiconductor Linear Application Specific IC's Databook 1993, p. 1-37.

Chapter 100

- Fig. 100-1. Reprinted with permission from Popular Electronics, Fact Card No. 269. (C) Copyright Gernsback Publications, Inc.
- Fig. 100-2. Analog Devices, The Best of Analog Dialogue, 1967-1991, p. 79.

Chapter 101

- Fig. 101-1. Reprinted with permission of National Semiconductor Corporation, National Semiconductor Linear Applications Handbook, 1991, p. 500.

- Fig. 101-2. Maxim, Vol. III, New Releases Data Book, 1994, p. 3-126.
- Fig. 101-3. Reprinted with permission from Electronic Design, 11/94, pp. 127-128. Copyright 1994, Penton Publishing, Inc.
- Fig. 101-4. Reprinted with permission of National Semiconductor Corporation, National Semiconductor Linear Applications Handbook, 1991, p. 207.
- Fig. 101-5. QST, 4/95, p. 61.
- Fig. 101-6. 73 Amateur Radio Today, 3/95, p. 63.
- Fig. 101-7. Reprinted with permission from Popular Electronics, 5/94, p. 80. (C) Copyright Gernsback Publications, Inc., 1994.
- Fig. 101-8. Reprinted with permission of National Semiconductor Corporation, National Semiconductor Linear Applications Handbook, 1991, p. 499.
- Fig. 101-9. Reprinted with permission from Popular Electronics, 5/94, p. 79. (C) Copyright Gernsback Publications, Inc., 1994.
- Fig. 101-10. Reprinted with permission of National Semiconductor Corporation, National Semiconductor Linear Applications Handbook, 1991, p. 206.

Chapter 102

- Fig. 102-1. Reprinted with permission from Popular Electronics, 11/94, p. 74. (C) Copyright Gernsback Publications, Inc., 1994.
- Fig. 102-2. Reprinted with permission from Popular Electronics, 5/94, p. 90. (C) Copyright Gernsback Publications, Inc., 1994.

- Fig. 102-3. Reprinted with permission from Electronic Design, 12/94, pp. 118-119. Copyright 1994, Penton Publishing, Inc.
- Fig. 102-4. Reprinted with permission from Electronics Now, 8/93, p. 14. (C) Copyright Gernsback Publications, Inc., 1993.
- Fig. 102-5. Reprinted with permission of National Semiconductor Corporation, National Semiconductor Linear Applications Handbook, 1991, p. 208.
- Fig. 102-6. Gordon McComb's Gadgeteer's Goldmine, McGraw-Hill, p. 197.
- Fig. 102-7. Amplifiers, Waveform Generators & Other Low-Cost IC Projects, McGraw-Hill, p. 21.
- Fig. 102-8. Reprinted with permission from Popular Electronics, 11/94, pp. 76 and 91. (C) Copyright Gernsback Publications, Inc., 1994.
- Fig. 102-9. Reprinted with permission from Electronic Design, 7/94, p. 96. Copyright 1994, Penton Publishing, Inc.
- Fig. 102-10. Power Supplies, Switching Regulators, Inverters, and Converters, McGraw-Hill, p. 129.
- Fig. 102-11. Reprinted with permission from Electronics Now, 3/95, p. 63. (C) Copyright Gernsback Publications, Inc., 1995.

Chapter 103

- Fig. 103-1. 73 Amateur Radio Today, 12/93, p. 70.
- Fig. 103-2. 73 Amateur Radio Today, 12/93, p. 72.

Chapter 104

- Fig. 104-1. William Sheets.
- Fig. 104-2. William Sheets.

Index

Numbers preceded by an "I", "II", "III", "IV", "V", or "VI" are from *Encyclopedia of Electronic Circuits* Vol. I, II, III, IV, V, or VI respectively.

A

- absolute-value circuits, I-37, IV-274
 - amplifier, I-31
 - full wave rectifier, II-528
 - Norton amplifier, III-11
 - precision, I-37, IV-274
 - ac amplifier, high input impedance, VI-55
 - ac line/timer interface, VI-281
 - ac motors (*see also* motor control circuits)
 - control for, II-375
 - power brake, II-451
 - three-phase driver for, II-383
 - two-phase driver for, I-456, II-382
 - ac power monitor, VI-351
 - ac/dc indicator, IV-214
 - ac-to-dc converters, I-165
 - fixed power supplies, IV-395
 - full-wave, IV-120
 - high-impedance precision rectifier, I-164
 - accelerometer, VI-345
 - acid rain monitor, II-245, III-361, V-371
 - acoustic field generator, V-338-341
 - acoustic sound receiver/transmitter, IV-311
 - active antennas (*see* antennas, active)
 - active filters (*see also* filter circuits)
 - band reject, II-401
 - bandpass, III-190, II-221, II-223
 - variable bandwidth, I-286
 - digitally tuned low-power, II-218
 - five pole, I-279
 - fourth-order low-pass, V-184
 - high-pass, V-180, V-188
 - fourth-order, V-188
 - second-order, I-297
 - low-pass, V-178, V-181, V-188
 - digitally selected break frequency, II-216
 - unity-gain, V-187
 - low-power
 - digitally selectable center frequency, III-186
 - digitally tuned, I-279
 - programmable, III-185
 - RC, up to 150 kHz, I-294
 - speech-range filter, V-185
 - state-variable, III-189
 - ten-band graphic equalizer using, II-684
 - three-amplifier, I-289
 - tunable, I-289
 - universal, II-214
- adapters (*see also* conversion and converters)
 - dc transceiver, hand-held, III-461
 - line-voltage-to-multimeter adapter, V-312
 - program, second-audio, III-142
 - traveller's shaver, I-495
- adder circuits, III-327
 - binary, fast-action, IV-260-261
- AFSK generator, one-chip, VI-23
- AGC (*see* automatic gain control (AGC))
- air conditioner, auto, smart clutch for, III-46
- aircraft receiver, 118- to 136-MHz, VI-542
- air motion and pressure barometer, VI-338
 - electronic anemometer, VI-6
- flow-detector, I-235, II-240-242, III-202-203, IV-82, V-154, VI-4-6, VI-183
- flow-meters (anemometers)
 - hot-wire, III-342, V-5, VI-4-6, VI-183
 - thermally based, II-241
- pressure change detector, IV-144
- motion detector, I-222, III-364
- airplane propeller sound effect, II-592
- alarms (*see also* annunciators; sirens)
 - I-4, III-3-9, IV-84-89, V-1-16, VI-7-16
 - 555-based alarm, V-11
 - alarm-tone generator, V-563
 - amateur radio on-alarm and timer, VI-32
 - audio-sensor alarm, V-8
 - auto burglar, I-3, I-7, I-10, II-2, III-4, IV-53
 - alarm decoy, VI-13
 - automatic-arming, IV-50
 - automatic turn-off, 8 minute delay, IV-52
 - CMOS low-current, IV-56
 - horn as loudspeaker, IV-54
 - motion-actuated car/motorcycle, I-9
 - security system, I-5, IV-49-56, VI-9, VI-11
 - single IC, III-7, IV-55
 - auto-arming automotive alarm, IV-50
 - automatic turn-off, IV-54
 - 8 minute delay, IV-52
 - baby-alert transmitter/receiver, V-95-96
 - backup battery low alarm, VI-110
 - bells, electronic, II-33, I-636
 - blown fuse, I-10
 - boat, I-9
 - body-heat detector, VI-266
 - burglar alarms, III-8, III-9, IV-86, VI-8
 - burglar chaser, V-16
 - latching circuit, I-8, I-12
 - NC and NO switches, IV-87
 - NC switches, IV-87
 - one-chip, III-5
 - self-latching, IV-85
 - timed shutoff, IV-85
 - camera triggered, III-444
 - capacitive sensor, III-515
 - current monitor and, III-338
 - dark-activated alarm, pulsed tone output, V-13
 - delayed alarm, V-4
 - differential voltage or current, II-3
 - digital clock circuit with, III-84
 - door-ajar, II-284, III-46, VI-14
 - Hall-effect circuit, III-256
 - door mûnder, V-5
 - doorbells (*see* annunciators)
 - driver, high-power alarm driver, V-2
 - exit delay for burglar alarms, V-10
 - fail-safe, semiconductor, III-6
 - field disturbance, II-507
 - flasher signal, V-197
 - flashing brake light for motorcycles, VI-12
 - flex switch alarm sounder, V-15
 - flood, I-390, III-206, IV-188, V-374
 - freezer meltdown, I-13
 - headlights-on, III-52, V-77
 - heat-activated alarm, V-9
 - high/low-limit, I-151
 - home security system, I-6, IV-87, VI-10-11
 - ice formation, II-58
 - infrared wireless system, IV-222-223
 - latching relay alarm circuit, VI-569
 - light-activated, V-9, V-273
 - high-output, pulsed tone, V-14
 - precision design, V-12
 - precision with hysteresis, V-14
 - self-latch, tone output, V-15
 - with latch, V-12
 - light-beam intruder-detection alarm, V-11, V-13
 - loop circuit alarms
 - closed-loop, V-3
 - multi-loop parallel alarm, V-2
 - parallel, V-3
 - series/parallel, V-3
 - low-battery disconnect and, III-65
 - low-battery warning, III-59
 - low-volts, II-493
 - motorcycle alarm, VI-13
 - motorcycle burglar alarm, VI-15
 - motorcycle horn alarm, VI-14; VI-15
 - multiple circuit for, II-2
 - no-doze alarm, V-8
 - one-chip, III-5
 - photoelectric, II-4, II-319
 - piezoelectric, I-12, V-10
 - power failure, I-581, I-582, III-511
 - printer error, IV-106
 - proximity, II-506, III-517, V-485-486, VI-657

- pulsed-tone, I-11, V-559
- purse-snatcher, capacitance operated, I-134
- rain, I-442, I-443, IV-189
- road ice, II-57
- security, I-4, III-3-9
- self-arming, I-2
- sensor amplifier, sensor amplifier, VI-52
- shutoff, automatic, I-4
- signal-reception, receivers, III-270
- silent alarm, V-16
- siren, V-559
- smoke alarms, II-278, III-246-253
 - gas, I-332
 - ionization chamber, I-332-333
 - line-operated, IV-140
 - operated ionization type, I-596
 - photoelectric, line-operated, I-596
 - SCR, III-251
- solar powered, I-13
- sonic defenders, IV-324
- spaceship alarm, V-560
- speed, I-95
- Star Trek red alert, II-577
- strobe flasher alarm, IV-180, V-6
- tamperproof burglar, I-8
- temperature (*see also* temperature-related circuits), II-4, II-643
 - adjustable threshold, II-644
 - light, radiation sensitive, II-4
- timer, II-674
- trouble tone alert, II-3
- turn signal use alarm, VI-100
- varying-frequency warning, II-579
- wailing, II-572
- warbling, II-573, V-7
- watchdog timer/alarm, IV-584
- water leakage/level (*see also* fluid and moisture), I-389, IV-190, V-374
- allophone generator, III-733
- alternators
 - battery-alternator monitor, car, III-63
 - regulator for automobile alternator, V-76
- altimeter, digital readout, V-296
- AM radio-related circuits, I-544
 - AM and shortwave, ac/dc vacuum-tube design, VI-536-537, VI-536
 - AM-modulated oscillator for wireless microphones, VI-450
 - amplitude modulator, II-370
 - broadcast band signal generator, IV-302
 - car radio to shortwave converter, IV-500
 - demodulator, II-160
 - detector, 455-kHz AM, VI-184
 - envelope detector, IV-142
 - linear (AM) amplitude modulator, VI-402
 - microphone, wireless AM microphone, I-679
 - modulation monitor, IV-299
 - power amplifier for, I-77
 - receivers, II-525, III-81, III-529, III-535, IV-455 V-496, VI-535
 - 1.5 V broadcast, V-497
 - mixer/oscillator for AM receiver, V-412
 - transistor radio, V-502
 - carrier-current, III-81
 - FM/AM receiver, VI-541
 - integrated, III-535
 - one-tube, VI-552
 - regenerative, one-tube, VI-547
 - two-chip, VI-550
 - shortwave radio AM broadcast trap, VI-214
 - signal generators, IV-301, IV-302
 - tuned collector oscillator, for AM broadcast band, VI-454
- AM/FM-related circuits
 - clock radio, II-543, III-1
 - squelch circuit, II-547, III-1
- amateur radio related circuits (*see also* amateur television), VI-17-32
 - AFSK generator, one-chip, VI-23
 - amplifier control circuitry, 1.2-kW 144-MHz, VI-19
 - amplifier power supply, 1.2-kW 144-MHz, VI-18
 - audio breakout box, VI-26-27
 - battery pack and reverse polarity protection, VI-30
 - CW audio filter, VI-29
 - CW identifier, programmable, VI-24
 - CW transmitter keying circuit, VI-22-23
 - CW transmitter, one-watt, VI-27
 - identifier circuit, VI-31
 - linear amp, 2-30 MHz 140-W, III-260
 - linear amplifier, VI-1.2-kW 144-MHz, VI-20
 - mobile radio on-alarm timer, VI-32
 - Morse code circuits, VI-404-409
 - PTT control from receiver audio, VI-28
 - receiver for, III-534
 - RF line sampler/coupler, VI-30
 - rf variable-frequency oscillator (VFO), V-532
 - SSB receiver, VI-80-meter, VI-29
 - superhet receiver, four-stage 75-meter, VI-21
 - SWR detector adapter, audible, VI-25
 - transceiver memory backup, VI-28
 - transceiver relay interface, V-243
 - transmit keyer interface circuit, VI-31
 - transmitter, 80-M, III-675
 - voice identifier, V-550
- amateur television (ATV) circuits, 33-45, VI-33
 - downconverter, 420 to 450 MHz, VI-44-45, VI-44
 - downconverter, 902 to 928 MHz, VI-40-41, VI-40
 - dummy load for transmitter tests, VI-37
 - horizontal deflection circuit, VI-382
 - mini transmitter, VI-36
 - parabolic dish microphone amplifier, VI-82
 - preamp, mast-mounted, VI-37
 - switching supply for color TV, SCR, VI-487
 - transmitter for 440 MHz, VI-5-watt, VI-34
 - transmitter, VI-5-watt, VI-35
 - transmitter, three-channel, 420- to 450-MHz, VI-4, VI-42
 - transmitter, three-channel, 902-to 928-MHz, VI-38, VI-38
 - UHF scanner active antenna, VI-67
 - vertical deflection circuit, VI-374
 - video detector for transmitter tests, VI-37
- ambience amplifier, rear speaker, II-458
- ambient light effects, cancellation circuit, II-328
- ambient light-ignoring optical sensor, III-413
- ammeter, I-201
 - low-current, V-307
 - nano, I-202
 - pico, II-154, II-157, I-202
 - guarded input circuit, II-156
 - six-decade range, II-153, II-156
- amplifiers (*see also* audio amplifiers), II-5-22, III-10-21, V-17-26, VI-46-57
 - 1 watt/2.3 GHz, II-540
 - 2 to 6-W, with preamp, II-451
 - 2 to 30 MHz, 140W amateur radio
 - linear, I-555
 - 4W bridge, I-79
 - 5W output, two-meter, I-567
 - 6W 8-ohm output-transformerless, I-75
 - 10 dB-gain, III-543
 - 10 W power, I-76
 - 10 x buffer, I-128
 - 12-W low-distortion power, I-76
 - 16-W bridge, I-82
 - 25-watt, II-452
 - 30 MHz, I-567
 - 40 dB gain, IV-36
 - 60 MHz, I-567
 - 80 MHz cascade, I-567
 - 80W PEP broadband/linear, I-557
 - 100 MHz/400 MHz neutralized common source, I-565
 - 100W PEP 420-450 MHz push-pull, I-554
 - 100x buffer, I-128
 - 135 to 175 MHz, I-564
 - 160W PEP broadband, I-556
 - 200 MHz neutralized common source, I-568
 - 450 MHz common-source, I-568
 - 600-W rf power, I-559
 - absolute-value, I-31
 - ac amplifier, noninverting, V-18, V-19
 - ac amplifier, high input impedance, VI-55
 - ac servo, bridge type, III-387
 - ac-coupled, dynamic, III-17
 - acoustic field generator, V-338-341
 - AF drive indicator, V-346
 - AGC, II-17
 - squelch control, III-33
 - wide-band, III-15
 - adjustable-gain noninverting, I-91
 - amateur radio, linear, 2 to 30 MHz, 140W, I-555
 - ambience, rear speaker, II-458
 - AM radio power, I-77
 - attenuator and, digitally controlled, I-53
 - audio (*see* audio amplifiers)
 - audio converter, two- to four-wire, II-14
 - audio limiter, low-distortion, II-15
 - audio power amps (*see* audio and sound circuits, power amps)
 - audio signal amps (*see* audio and sound circuits, signal amps)
 - audio-to-UHF preamp, V-24
 - automatic fade circuit for, II-42
 - automatic level control, II-20
 - automotive audio amplifier, IV-66
 - Av/200, stereo, I-77
 - balance, II-46

- amplifiers, *continued*
- inverting, I-33
 - loudness control, II-47, II-395
 - bandpass amplifier, VI-54
 - bootstrap circuit, V-356
 - bridge, I-74
 - 4 watt, I-79
 - 16 watt, I-82
 - ac servo, I-458
 - audio power, I-81
 - high-impedance, I-353
 - transducer, III-71, II-84, I-351
 - broadband
 - low-noise, I-562
 - PEP, 160-W, I-556
 - linear/PEP, 80W, I-557
 - bridge amplifier, VI-122, VI-123
 - buffers
 - 10x, I-128
 - 100x, I-128
 - ac, single-supply, I-126
 - battery-powered, I-351
 - rf amp with modulator, IV-490
 - sine-wave output, I-126
 - unity-gain, stable design, II-6
 - car stereo booster amp, V-72
 - cascade, III-13
 - 80 MHz, I-567
 - cascode, rf amplifiers, IV-488
 - CD4049 audio signal amp, IV-40
 - chopper, $\pm 15V$, III-12
 - chopper channel, I-350
 - stabilized, II-7
 - clamp-limiting, active, III-15
 - color video, I-34, III-724
 - common source
 - 450 MHz, I-568
 - low-power, II-84
 - complementary-symmetry audio, I-78
 - composite, II-8, III-13
 - compressor/amplifier, low-distortion, IV-24
 - constant-bandwidth, III-21
 - control circuitry, 1.2-kW 144-MHz, VI-19
 - cool-down circuit, V-354, V-357
 - crystal tuned amp, VI-57
 - current feedback amp, 100 mA at 100 MHz, V-25
 - current-shunt, III-21
 - current collector head, II-11, II-295
 - current probe amplifier, VI-521
 - current-to-voltage, high-speed, I-35
 - Darlington, push-pull, V-22
 - dc servo, I-457
 - dc-stabilized, fast, III-18
 - dc-to-video log, I-38
 - detector, MC1330/MC1352, TV IF, I-688
 - difference amplifier, V-18, V-21, VI-53
 - differential, I-38, III-14
 - high-impedance, I-27, I-354
 - high-input, high-impedance, II-19
 - instrumentation, I-347, III-283
 - instrumentation, biomedical, III-282
 - programmable gain, III-507
 - two op amp bridge type, II-83
 - discrete current-booster, V-23
 - distribution amplifiers
 - audio, I-39, II-39, V-59
 - signal, I-39
 - dual power supply, V-465
 - dynamic, ac-coupled, III-17
 - car protector circuit, V-482
 - electret microphone preamp, V-21
 - electrometer, overload protected, II-155
 - fast-inverting, high-input impedance, V-18
 - FET input, II-7
 - offset gate bias, V-22
 - video, cascade, I-691
 - flat response, I-92, III-673
 - forward-current booster, III-17
 - four-quadrant photo-conductive detector, I-359
 - frequency counter preamp, V-24
 - gain, 10 dB, III-543
 - gain-controlled, III-34
 - gate, I-36
 - guitars, matching audio signal amps, IV-38
 - harmonic distortion analyzer, V-291
 - harmonic distortion meter, V-312
 - hi-fi compander as, II-12
 - hi-fi expander, II-13
 - high-frequency amplifiers, III-259-265
 - 29-MHz, III-262
 - 3-to-30 MHz, 80-W, 12.5-13.6 V, III-261
 - amateur radio, linear, 2-30 MHz 140-W, III-260
 - noninverting, 28-dB, III-263
 - RF, broadcast band, III-264
 - UHF, wideband with high-performance FETs, III-264
 - wideband, III-265
 - high-impedance/high-gain/high-frequency, I-41
 - high-impedance/low-capacitance, I-691
 - high-input-high-impedance amplifiers, II-19, II-44
 - high-side current-sensing amp, VI-54
 - highpass amplifier, VI-49
 - IF amplifiers, I-690, IV-459
 - 455-kHz, V-522, V-523, V-524
 - 45-MHz, crystal filter, V-527
 - AGC system, IV-458
 - preamp, IV-460
 - receiver, IV-459
 - quadrature detector, TV sound IF, I-690
 - two-stage, 60 MHz, I-563
 - wideband, I-689
 - infinite sample and hold, II-558
 - input-inverting, fast, high-impedance, V-19
 - input/output buffer for analog multiplexers, III-11
 - instrumentation amplifiers, I-346, I-348, I-349, I-352, II-293-295, III-278-284, IV-229-234, V-233-235
 - ± 100 V common mode range, III-294
 - current collector head amplifier, II-295
 - differential, I-347, I-349, I-353, I-354, III-282, III-283
 - extended common-mode design, IV-234
 - high-impedance low-drift, I-355
 - high-speed, I-354
 - low-drift/low-noise dc amplifier, IV-232
 - low-signal level/high-impedance, I-350
 - low-power, III-284
 - meter driver, II-296
 - preamps, III-283, IV-230-231
 - precision FET input, I-355
 - saturated standard cell amplifier, II-296
 - strain gauge, III-280
 - triple op amp, I-347
 - ultra-precision, III-279
 - variable gain, differential input, I-349
 - very high-impedance, I-354
 - wideband, III-281
 - inverting, I-42, II-41, III-14
 - ac, high-gain, I-92
 - balancing circuit in, I-33
 - gain of 2, lag-lead compensation, UHF, I-566
 - low-power, digitally selectable gain, II-333
 - power amplifier, I-79
 - programmable-gain, III-505
 - unity gain amplifier, I-80
 - wideband unity gain, I-35
 - ISD 1000A record/playback circuit, VI-50
 - isolation
 - capacitive load, I-34
 - level-shifting, I-348
 - medical telemetry, I-352
 - rf, II-547
 - JFET, V-20
 - 500-Mohm input impedance, V-23
 - bipolar cascade video, I-692
 - current source biasing, V-21
 - preamplifier, V-22
 - line amps, III-37
 - duplex, telephone, III-616
 - universal design, IV-39
 - linear amplifiers
 - 2-kW 144-MHz, VI-20
 - 2-30 MHz, 140W PEP amateur radio, I-555
 - 100 W PEP 420-450 MHz push-pull, I-554
 - 160 W PEP broadband, I-556
 - amateur radio, 2-30 MHz 140-W, III-260
 - audio power amplifiers, V-51
 - CMOS inverter, II-11
 - inverter, linear amp from inverter, II-11
 - rf, IV-480-481, IV-484-485
 - load-line protected, 75W audio, I-73
 - logarithmic amplifiers, I-29, I-35, II-8
 - dc to video, I-38
 - log-ratio amplifier, I-42
 - op amp, VI-56
 - logic amplifiers, II-332-335
 - low-power binary, to 10n gain
 - low-frequency, II-333
 - low-power inverting, digitally selectable gain, II-333
 - low-power noninverting, digitally selectable input and gain, II-334
 - precision, digitally programmable input and gain, II-335
 - programmable amplifier, II-334
 - log ratio, I-42
 - loudness control, II-46
 - low-level video detector circuit and, I-687
 - low-noise design, IV-37
 - lowpass amplifier, VI-49
 - medical telemetry, isolation, I-352

motor-driver, rf, 1-MHz, III-545
 micro-powered, high-input/high-impedance, 20 dB, II-44
 micro-sized, III-36
 microphone, I-87, III-34
 electronically balanced input, I-86
 microwave amplifiers, IV-315-319
 5.7 GHz, IV-317
 bias supply for preamp, IV-318
 preamplifiers, IV-316-319
 mini-stereo amplifier, V-583
 monostable, II-268
 MOSFET
 high-impedance biasing method, V-19
 push-pull amplifier, VI-55
 neutralized common source, I-565, I-568
 noninverting amplifiers, I-32, I-33, I-41, III-14
 ac power, I-79
 adjustable gain, I-91
 comparator with hysteresis in, I-153
 high-frequency, 28-dB, III-263
 hysteresis in, I-153
 low-power, digitally selectable input and gain, II-334
 power, I-79
 programmable-gain, III-505
 single supply, I-74
 split supply, I-75
 Norton, absolute-value, III-11
 op amp (*see* operational amplifiers)
 oscilloscope sensitivity, III-436
 output, four-channel D/A, III-165
 pH probe amplifier, VI-523
 phono, I-80, I-81, I-89
 photodiode, I-361, II-324, III-19, III-672, VI-301, VI-302
 phototransistor amplifier, V-409
 playback, tape, III-672
 polarity-reversing low-power, III-16
 power (*see* power amps)
 power supply, V-464, V-465, VI-18
 pre-amps (*see* preamplifiers)
 precision amplifier, I-40, II-335
 precision RTD, for +5 V, VI-643
 programmable amplifiers, II-334, III-504-508
 differential-input, programmable gain, III-507
 inverting, programmable-gain, III-505
 noninverting, programmable-gain, III-505
 precision, digital control/programming, III-506
 programmable-gain, I-32, II-9
 variable-gain, wide-range digital control, III-506
 programmable gain, I-32, II-9, VI-51
 programmable input, VI-52
 pulse-width proportional controller circuit for, II-21
 push-pull
 Darlington, V-22
 MOSFET, VI-55
 PEP 100-W, 420-450 MHz, I-554
 PWM servo, III-379
 recording amplifier, I-90
 reference voltage, I-36
 remote, I-91, VI-50
 remotely powered sensor amplifier, VI-52
 rf (*see* rf amplifiers)
 sample-and-hold, I-587, II-558
 selectable input, programmable gain, I-32
 servo amplifiers (*see also* motor controls), I-452
 400 Hz, II-386
 bridge type ac, I-458
 dc, I-457
 motor drive amplifier, II-384
 signal amplifiers, audio, II-41-47, IV-34-42
 signal distribution, I-39
 sound-activated, gain-controlled, IV-528
 silicon-controlled amplifiers (SCA), V-535-536
 decoder, I-214, II-166, II-170
 demodulator, II-150, III-565
 subcarrier adapter, FM tuner, V-536
 sinewave output buffer, I-126
 sound mixer and, II-37
 source follower
 bootstrapped, V-20
 JFET, V-20
 speaker amplifiers, II-16, III-39
 speech compressor, II-15
 stereo amplifiers, I-77, II-9, III-34
 bass tone control, V-584
 subwoofer power supply, V-464
 summing, I-37, III-16
 fast-action, I-36
 inverting, V-18, V-20
 precision design, I-36
 video, III-710, VI-681
 switching power, I-33
 tape playback, I-92, IV-36
 tape recording, I-90
 telephone, III-621, IV-555, IV-560, V-614
 telephone ring amplifier, VI-624, VI-626
 test bench amplifier, V-26
 tester, VCR head amplifier, VI-48
 thermocouple, I-654, III-14
 cold junction compensation in, II-649, VI-642
 high-stability, I-355
 transducer, I-86, III-669-673
 transformerless, 6-W, 8-ohm output, I-75
 transistorized, I-85, II-43
 tremolo circuit, voltage-controlled, I-598
 tube amplifier, high-voltage isolation, IV-426
 tuned amplifier, VI-53
 TV audio, III-39
 two-meter, I-582, I-567
 two-stage, I-563, I-689
 UHF, I-560, I-565
 unity gain, I-27, II-7
 noninverting, V-21, V-22
 variable-gain, for oscilloscopes, V-426
 VHF, single-device, 80-W/50-ohm, I-558
 video, I-692, III-708-712, V-655, V-656, V-657, V-658, V-662, VI-674, VI-679, VI-681, VI-683
 75-ohm video pulse, III-711
 250-mA 60-MHz current feedback, VI-682
 buffer, low-distortion, III-712
 color, I-34, III-724
 dc gain-control, III-711
 FET cascade, I-691
 gain block, III-712
 IF, low-level video detector circuit, I-689, II-687
 JFET bipolar cascade, I-692
 line driving, III-710
 log amplifier, I-38
 RGB, III-709, VI-675
 summing, III-710, VI-681
 video IF amplifier/detector, VI-678
 voice activated switch, I-608
 voice-operated circuits, V-553
 voltage, differential-to-single-ended, III-670
 voltage indicators/meters, VI-689
 voltage-controlled (*see* voltage-controlled amplifiers)
 voltage-follower, signal-supply operation, III-20
 voltmeter amplifier, low-drain, VI-695
 volume, II-46
 walkman, II-456
 write, III-18
 amplitude modulation (*see* AM radio-related circuits; AM/FM)
 analog circuits
 counter circuit, II-137
 delay line, echo and reverb, IV-21
 multiplexers, II-431, III-396
 multiplier, II-392
 switch, differential analog switch, I-622
 analog-to-digital converter, II-23-31, III-23-26, IV-5-6, V-27-30, VI-58-60
 3-bit, high-speed, I-50
 8-bit, I-44, I-46
 8-bit successive approximation, I-47
 10-bit, II-28
 10-bit serial output, II-27
 12-bit, high-speed, II-29
 16-bit, II-26
 board design, IV-6
 buffer circuit, I-127, VI-128
 capacitance meter, 3.5 digit, III-76
 cyclic, II-30
 differential input system for, II-31
 eight-channel, for PC clones, V-29-30, V-29
 fast precision, I-49
 four-digit (10,000 count), II-25
 half-flash, III-26
 high-speed system, VI-59
 IC, low-cost, I-50
 LCD display, 3.5 digit, I-49
 personal computer A/D converter, VI-60
 poller, V-28
 successive approximation, II-24, II-30, I-45
 switched-capacitor, III-23
 temperature measurement converter, VI-234-235, VI-634
 three-decade logarithmic, I-48
 three-IC, low-cost, I-50
 tracking, III-24
 video converter, IV-610-611
 analyzer, gas, II-281
 AND gate, I-395, V-216, VI-315
 large fan-in, I-395
 relay circuit, VI-316
 anemometers (*see also* air motion/pressure), VI-4-6
 hot-wire, III-342, VI-5
 thermally based, II-241
 angle-of-rotation detector, II-283

annunciators (*see also* alarms; sirens), II-32-34, III-27-28, IV-710

ac line-voltage, III-730

bell, electronic I-636, II-33, IV-9

buzzers, I-11, I-12, IV-8, V-170

chime circuit, low-cost, II-33

door buzzer, IV-8

doorbells/chimes, I-218, I-443, IV-8 buzzer, V-170

buzzer, two-door, IV-10

musical-tone, IV-522

rain alarm, I-443

single-chip design, IV-524

sliding tone, II-34

twin-bell, V-170

large fan-in, I-395

SCR circuit, self-interrupting load, IV-9

twin-bell doorbell, V-170

two-door annunciator, IV-10

answering machines (*see also* telephone-related circuits)

beeper, IV-559

antennas, IV-11-14, V-31-38, VI-61-67

active, III-1-2, IV-1-4

wideband rod, IV-4

with gain, IV-2

balun, V-34

FM automobile radio diversity antenna, VI-64-65

FM tunable antenna booster, VI-65

HF broadband antenna preamp, V-36

HF/VHF switchable active antenna, V-524

loop antenna, 3.5 MHz, IV-12-13

dual band, 80-16-M, V-32

preamp, V-38

matchbox antenna tuner, VI-66

miniature broadband (3 to 30 MHz), VI-63

preamps

HF broadband, V-36

VLF 60-kHz, V-33

wideband antenna, V-35

remote tuned active HF, VI-62

selector switch, IV-538-539

TR switch, automatic, V-37

tuner, VI-66

1- to 30-MHz, IV-14

low-power, V-38

UHF scanner active antenna, VI-67

VLF 60-kHz antenna preamp, V-33

VLF/VHF wideband, low-noise, active, V-33

wideband antenna, preamp, V-35

antihelit device, I-7

arc lamp, 25-W, power supply for, II-476

arc welding inverter, ultrasonic, 20 kHz, III-700

arc-jet power supply, starting circuit, III-479

astable multivibrators, II-269, II-510, III-196, III-233, III-238, V-387, V-388, VI-418, VI-419

op amp, III-224

free-running square-wave oscillator, V-386

programmable-frequency, III-237

square wave generation with, II-597

starting network, VI-418

variable pulse width, VI-419

attendance counter, II-138

attenuators, III-29-31, VI-68-70

analog signals, microprocessor-controlled, III-101

digitally programmable, III-30

digitally selectable, precision design, I-52

programmable, III-30

programmable (1 to 0.00001), I-53

rf, IV-322

switchable power, VI-69

variable, I-52

variable voltage, VI-70

voltage-controlled, II-18, III-31

audio amplifiers (*see also* amplifiers; audio and sound circuits; audio power amplifiers), II-41-47, III-32-39, IV-34-42, VI-71-82

10-watt amplifier, VI-85

20-dB gain amp, VI-78

40 dB gain design, IV-36

AGC, squelch control, III-33

audio compressor, II-44

automotive stereo system, high-power, IV-66, VI-101

balance, II-46, II 47, IV-215

Baxandall tone control, IV-588

booster, 20 dB, III-35

CD4049 design, IV-40

circuit bridge load drive, III-35

class AB single-supply amp, complementary, VI-81

complementary-symmetry, I-78

compressor, II-44

distribution, I-39, II-39

electric guitar, IV-38

electronic-ear low noise amp, parabolic dish microphones, VI-82

fader, automatic, II-42

fixed power supplies, IV-398, IV-407

high-gain amp, VI-80

high-slew rate power op amp, I-82

gain-controlled, stereo, III-34

line amplifier, III-37, IV-39

linear amp, micropower, VI-73

load line protection, 75W, I-73

loudness, II-46

low-level amp, VI-78

low-noise design, IV-37

low-power, II-454

micro-sized, III-36

microphone, II-45, III-34, VI-81

micropower high-input-impedance 20-dB amplifier, II-44

mini-stereo, III-38

NB FM audio amp, VI-74

personal stereo amplifier, VI-75

power (*see* audio power amplifiers)

power supply, V-465, VI-483

pre-amps

1000x low-noise, IV-37

AGC, VI-2

balanced microphone, VI-77

dynamic microphone, VI-76, VI-79

FET phono cartridge, VI-79

general-purpose, IV-42

impedance-matching, IV-37

low-noise, IV-41

magnetic phono cartridge, IV-35

microphone, IV-37, IV-41, IV-42

NAB tape playback, professional, III-38

phono, III-37, IV-35, IV-36

RIAA, III-38, VI-80

single-ended high- z microphone, VI-78

stereo, II-43, II-45

transistor RIAA for telephone, VI-76

Q-multiplier, II-20

RIAA line amplifier/driver, VI-77

signal (*see* audio signal amplifiers)

signal source for audio amplifier/inverter, VI-702

speaker, hand-held transceivers, III-39

tape playback amplifiers, IV-35

television type, III-39

test circuit, VI-343

tone control, II-686

transistor headphone amplifier, II-43

two-transistor design, VI-74

ultra-high-gain, I-87

vacuum tube amplifier, VI-72-73

vehicle audio amplifier inverter, VI-284

volume indicator, II-46, IV-212

audio and sound circuits (*see also* audio amplifiers; sound generators; sound-operated circuits)

acoustic field generator, V-338-341, V-338

acoustic sound receiver/transmitter, IV-311

AF drive indicator, V-346

amplifiers (*see* audio amplifiers)

audio-frequency generator, V-416-417

audio-frequency meter, V-305, V-320

audio-rf signal tracer probe, I-527

audio-sensor alarm, V-8

audio-test oscillator, V-420

audio-to-ADC interface, V-242

audio-to-UHF preamp, V-24

automatic gain control (AGC), II-17

automatic level control (ALC), V-62

AGC system for CA3028 IF amp, IV-458

rf amplifier, wideband adjustable, III-545

squelch control, III-33

wide-band amplifier, III-15

booster, II-455, III-35

biquad filter, III-185

bridge load drive, III-35

carrier-current transmitter, III-79

clipper, precise, II-394

compressor, II-44

continuity tester, I-550

converter, two- to four-wire, II-14

CW audio filter, VI-405

CW identifier, VI-408

distribution amplifier, I-39, II-39

ditherizer, VI-377

dual tone generator, VI-390

expander, V-582

filters (*see* filters)

frequency doubler, IV-16-17

frequency meter, I-311, VI-335

gain control, remote, VI-384

generators (*see* sound generators)

LED bar peak program meter display, I-254

level meters, sound levels, III-346, III-614, IV-305, IV-307

leveler, ALC, VI-3

limiters, II-15, V-335

millivoltmeter, III-767, III-769

mixers (*see* mixers)

muting circuit, VI-383

noise-based voting circuit, VI-422-423
 notch filter, II-400
 octave equalizer, V-353
 oscillators, I-64, II-24, III-427, IV-374, IV-375, VI-432-440
 20 Hz to 20 kHz, variable, I-727
 light-sensitive, III-315
 sine wave, II-562
 power (*see* audio power amplifiers)
 power meter, I-488
 power supply for auto sound amp, VI-483
Q multiplier, II-20
 receivers (*see* receivers)
 rf signal tracer probe, I-522
 scramblers, IV 25-27
 selector, digital, V-158
 signal amplifiers (*see* audio signal amplifiers)
 sine wave generator, II-564
 squelch, II-394
 switches
 eight-channel, V-588-589
 video/audio switch, V-586
 switching/mixing, silent, I-59
 telephone/audio interface, VI-625
 transmitters (*see* transmitters)
 waveform generators, III-230
 audio generators (*see* sound generators)
 audio-operated circuits (*see* sound-operated circuits)
 audio power amplifiers, II-451, III-454, IV-28-33, V-39-51, VI-83-93
 1.5 watt, VI-12 V, VI-84
 6-W, with preamp, III-454
 10-watt, VI 85
 18-W bridge, V-49
 20-W, III-456
 33-W bridge composite, V-46
 40 W, V-41
 50-W, III-451
 70 W, composite, V-44-45
 80-watt IC, VI-91
 90-W 10-A high power, VI-93
 AF amplifier, VI-92
 audio amplifier, IV-32
 basic design, V-51
 bridge, I-81, V-49, VI-88
 bridge connection of two power op amps, VI-92
 bridge composite, V-46
 bull horn, IV-31
 class-AB amp, VI-86
 complementary amp circuit, VI-91
 composite,
 33-W bridge, V-46
 70 W, V-44-45
 inverting 10W, V-47
 noninverting 10W, V-47
 dual, V-42-43
 general-purpose, 5-W, ac, IV-30
 half-watt, single-channel, V-41
 inverting composite, 10W, V-47
 line-operated, VI-86
 linear, fast, high-voltage, V-51
 mini-megaphone, VI-93
 MOSFET, V-47
 noninverting composite 10W, V-47
 op amp, simple design, IV-33
 parallel power op amp, VI-84
 personal-stereo type, V-48
 phono amp, VI-90
 power bridge amp with single-ended output, VI-85
 quasi-complementary, VI-90
 quasi-complementary, split power supplies, VI-89
 receiver audio circuit, IV-31
 RFI-proof, VI-88
 RLAA phono amplifier, VI-89
 stereo amp, IV 29, V-40
 subwoofer amp, V-49, V-50
 vacuum tube amplifier, VI-87
 audio signal amplifiers, II-41-47, IV-34-42, V 52-59
 booster, V-58
 compressor, audio, V-57
 audio signal amplifiers, constant-volume, V-55
 distribution amplifier, V-59
 dual preamp, V-58
 headphone amplifier, V-53
 headphone amplifier, JFET, V-57
 line driver, V-54
 mini-amp, V-55
 phonograph, magnetic pickup, V-58
 tunable-filter design, V-56
 volume limiter, V-59
 audio-frequency generator, V-416-417
 audio-frequency meter, V-305, V-320
 audio to-UHF preamp, V-24
 audio/video switcher circuit, IV-540-541
 auto-advance projector, II-444
 autodrum sound effect, II-591
 auto-lade circuit, II-42
 auto-flasher, I-299
 auto-zeroing scale bridge circuits, III-69
 automatic gain control (AGC), II-17, VI-1
 AGC system for CA3028 IF amp, IV-458
 audio preamp, VI-2
 IF network AGC, VI-3
 low-noise 3-MHz AGC, VI-2
 rf amplifier, wideband adjustable, III-545
 squelch control, III-33
 wide-band amplifier, III-15
 automatic level control (ALC), V-60-62, VI-1
 AGC system for audio signals, V-62
 basic design, V-62, VI-3
 digital design, V-61
 automotive circuits, II-48-63, III-40-52, IV-43-67, V-63-77, VI-94-104
 accessory-power controller, V-70
 alarms (*see* also alarms/security circuits), V-1
 automatic-arming, IV-50
 automatic turn off, IV-52
 CMOS design, low-current, IV-56
 decoy, VI-13
 horn as loudspeaker, IV-54
 single-IC design, IV-55
 air conditioner smart clutch, III-46
 alternator/battery monitor, III-63, V-88, VI-97
 alternator regulator, V-76
 AM radio to shortwave converter, IV-500
 amplifier, booster for car stereo, V-72
 analog expanded-scale meter, IV-46
 audio-amplifier, high-power, IV-66, VI-101
 audio amplifier inverter, VI-284
 audio system power supply, VI-103
 back-up beeper, III-49, IV-51, IV-56
 bar-graph voltmeter, II 54
 battery chargers/monitors (*see* also battery-related circuits)
 charger, ni-cad, I-115
 condition checker, I-108
 current analyzer, I 104
 electric vehicle battery saver, III-67
 isolator circuit, VI-104
 monitor, I-106, I-222, III-60-67
 supply circuit, \pm 15- and 5-V, IV-391
 battery cranking-amps tester, V-84
 battery/alternator monitor, V-88
 brake and turn indicator, V-74
 brake lights, V-65
 delayed extra, III-44
 flashing, V-69, VI-12
 flashing third, III-51
 night-safety light for parked car, IV-61
 third brake light, IV-60
 burglar alarms, I-3, I-7, I-10, II-2, III-4, III-7, IV-53
 cassette recorder power circuit, IV-548
 cigarette lighter 9-V adapter, VI-97
 courtesy lights
 delay switch, III-42
 light extender, III-50
 dc power adapter, V-70
 digi-tach, I-61
 directional signals monitor, III-48
 door ajar monitor, III-46
 electric vehicles, battery saver, III-67
 electrical monitor, VI-96
 electrical tester, IV-45
 electronic circuits, IV-63-67
 engine-block heater reminder, V-74
 exhaust emissions analyzer, II-51
 fan thermostat switch, V-68
 FM radio diversity antenna, VI-64-65
 fog light controller with delay, IV-59
 fuel gauge, digital readout, IV-46
 fuse monitor, V-77
 garage stop light, II-53
 generator regulator, V-76
 glow-plug driver, II-52
 headlights, IV-57-62
 alarm, III-52, V-77
 automatic-off controller, IV-61, V-75
 delay circuit, I-107, II-59, III-49
 dimmer, II-57, II-63
 flasher, V-73
 monitor, VI-104
 on-lights reminder, V-74, V-77
 switching circuit, V-75
 headlight/spotlight control, V-67
 high-speed warning device, I-101
 ice formation alarm, II-58
 ignition circuit, V-64
 capacitor discharge, VI-102-103
 cut-off, IV-63
 electronic ignition, IV-65
 substitute ignition, III-41
 timing light, II-60
 immobilizer, II-50
 kill-switch for battery, time-delayed, V-71-72
 light circuits, IV-57-62
 lights-on warning, II-55, III-42, IV-58, IV-60, IV-62
 locator; automobile locator, III-43

automatic level control (ALC), *continued*
 motorcycle alarm, VI-13
 burglar alarm, VI-15
 flashing brake light, VI-12
 headlight monitor, VI-104
 horn alarm, VI-14, VI-15
 tune-up aid, VI-359
 turn-signal system, VI-98
 night-safety light for parked car, IV-61
 oil pressure gauge, digital readout, IV-44, IV-47
 PTC thermistor automotive temperature indicator, II-56
 power supply, VI-483, VI-513
 radio receiver, II-525
 radio WWV converter, V-119
 read-head pre-amplifier, III-44
 road ice alarm, II-57
 security system, I-5, IV-49-56, VI-9, VI-11
 spotlight/headlight control, V-67
 stethoscope for automobiles, VI-95
 tachometers, I-94, I-100, I-102, II-175, III-335, III-340, III-347, V-65, VI-98
 analog readout, IV-280
 calibrated, III-598
 closed loop feedback control, II-390
 digital readout, II-61, III-45, IV-268-269, IV-278
 dwell meter/tachometer, III-45
 feedback control, II-378, II-390
 frequency counter, I-310
 low-frequency, III-596
 minimum-component design, I-405
 motor speed controllers, II-378, II-389
 optical pick-up, III-347
 set point, III-47
 temperature gauge
 digital readout, IV-48
 PTC thermistor, II-56
 test light, high-Z, VI-104
 thermostatic switch for auto fans, V-68
 turn signals, V-65
 alarm, VI-100
 motorcycle, VI-98
 audible reminder, V-74
 monitor, III-48
 sequential flasher for, II-109, III-1
 smart, V-66-67, VI-99
 reminder, V-73
 vacuum gauge, digital readout, IV-45
 voltage gauge, IV-47
 voltage regulator, III-48, IV-67
 voltmeter, bargraph, I-99
 water temperature gauge, IV-44
 windshield wiper circuits, I-105, II-55, II-62
 control circuit, I-103, I-105, II-62
 delay circuit, II-55, IV-64
 hesitation control unit, I-105
 intermittent, dynamic braking, II-49
 interval controller, IV-67
 slow-sweep control, II-55
 windshield washer fluid watcher, I-107
 WWV converter for radio, V-119
 averaging circuit, VI-324

B

B-field measurer, IV-272
 baby monitor, V-370-371
 baby-alert transmitter/receiver, V-95-96
 back-biased GaAs LED light sensor, II-321
 back-EMF PM motor speed control, II-379
 backup-light beeper, car, IV-51, IV-56
 bagpipe sound effect, IV-521
 balance indicator, audio amps, IV-215
 balance meter, stereo, V-583
 balancer, stereo, I-619
 balance amplifiers, III-46
 loudness control in, II-395
 balance indicator, bridge circuit, II-82
 balun, V-34
 band reject filter, active, II-401
 bandpass filter (*see also* filter circuits), II-222, V-180, V-181, VI-220
 0.1 to 10 Hz, I-296
 160 Hz, I-296
 active, II-221, II-223, III-190, VI-210
 1 kHz, I-284
 20 kHz, I-297
 60 dB gain, I-284
 variable bandwidth, I-286
 amplifier, VI-54
 biquad, I-285, III-188, V-190
 Chebyshev fourth-order, III-191
 high-Q, I-287, V-179
 MFB, multichannel tone decoder, I-288
 multiple feedback, I-285, I-297, II-224
 notch, II-223
 one op-amp design, VI-222
 Sallen-Key, 500 Hz, I-291
 second-order biquad, III-188
 speech-range filter, V-185
 static variable, I-290
 tunable, IV-171
 two op-amp design, VI-216
 variable bandpass, V-184
 variable-frequency, V-186
 bandswitching for receiver, VI-608
 bang-bang power controllers, IV-389
 bar-code scanner, III-363
 bar-expanded scale meter, II-186
 bar graphs
 ac signal indicator, II-187
 voltmeters, II-54, II-99
 barricade flasher, I-299
 barometer, IV-273, VI-338
 bass tone control in stereo amplifier, V-584
 bass tuner, II-362
 12 V, I-111
 200 mA-hour, 12V Ni-Cad, I-114
 automatic shutoff for, I-113
 battery-operated equipment (*see also* battery-related circuits)
 ac power control switch, IV-387
 automatic shutoff, III-61
 bipolar power supply, II-475
 black light, V-281
 buffer amplifier for standard cell, I-351
 calculators/radios/cassette players, power pack, I-509
 cassette deck power circuit, car, IV-548
 fence charger, II-202
 flasher, high-powered, II-229
 lantern circuit, I-380
 light, capacitance operated, I-131
 On indicator, IV-217
 undervoltage indicator for, I-123
 warning light, II-820
 battery-related circuits (*see also* battery-operated equipment), V-82-89
 12-V battery status indicator, VI-120
 AA cells, +5 V/+3.6 V power supply, V-452
 alarm, VI-110-111
 automotive battery isolator, VI-104
 battery-life extenders, IV-72, V-87
 9-V, III-62
 disconnect switch, IV-75
 electric vehicles, III-67
 butler, battery butler, VI-116-117
 capacity tester, III-66
 car battery/alternator monitor, V-88
 chargers, I-113, II-64, II-69, III-53-59, IV-68-72, V-78-81, VI-105-113, VI-118
 12-V charger, IV-70
 constant voltage, current limited, I-115
 controller for charger, VI-107
 current limiter for charger, VI-108
 intelligent circuit, V-81
 lead-acid trickle charger, VI-112
 lithium charger, VI-108, VI-109, VI-112
 mobile charger, +12 Vdc, IV-71
 ni-cad, I-112, I-116, III-57, VI-109, VI-111, VI-113
 photoflash capacitor, VI-466
 rf type, V-79
 smart charger circuit, VI-106
 solar-powered, V-81
 temperature sensing charger, IV-77
 trickle charger, lead-acid, V-79
 checkers (*see* battery monitors, below)
 condition checker, I-108, I-121
 control for 12V, I-112
 converter, dc-to-dc, IV-119
 cranking-amp test circuit, V-84
 current limited 6V, I-118, IV-70
 current monitor, 0-2 A batteries, V-87
 disconnect switch, life-extender, IV-75
 dynamic constant current test, II-75
 fixed power supply, 12-VDC/120-VAC, III-464
 gel cell, II-66
 high-voltage generator, III-482
 indicators (*see* battery monitors, below)
 internal resistance tester, IV-74
 kill-switch, time-delayed, V-71-72
 lead/acid, III-55
 level indicator, II-124
 lithium, II-67
 backup battery replacement, VI-120
 charge indicator, II-78
 low-battery detection/warning, I-124, II-77, III-56, III-59, III-63, III-65, IV-56, IV-80, VI-118
 low-cost trickle for 12V storage, I-117

- monitors, I-106, I-222, II-74-79, III-60-67, IV-73-80, V-82-83, VI-110-111, VI-114-120
- ni-cad batteries, I-118
- analyzer for, III-64
- charger, I-112, I-116, III-57, VI-109, VI-111, VI-113
 - 12 v, 200 mA per hour, I 114
 - current and voltage limiting, I-114
 - fast-acting, I-118
 - portable, IV-69
 - temperature-sensing, IV-77
 - thermally controlled, II-68
- packs, automotive charger for, I-115
- portable, III-47, IV-69
- protection circuit, III-62
- simpli-cad, I-112
- temperature-sensing charger, IV-77
- test circuit, IV-79
- thermally controlled, II-68
- zappers, I-6, II-66, II-68
- power supply and, 14V, II-73, III-42
- probe for battery charger, VI-118
- protection circuit, ni-cads, III-62
- PUT, III-54
- rechargeable LED flashlight, VI-107
- regulator, I-117
- relay fuse, V-88
- reverse polarity protection, VI-30
- saver circuit, V-87
- sensor, quick deactivating, III-61
- simpli-cad, I-112
- solar cell, II-71
- splitter, III-66
- status indicator, II-77
- step-up switching regulator, 6-V, II-78
- supply-voltage monitor, V-85
- test circuits, IV-78, V-83, V-86
 - LED bargraph, V-89
 - ni-cad, IV-79
- thermally controlled ni-cad, II-68
- threshold indicator, I-124
- UJT, III-56
- undervoltage indicator, I-123, VI-117
- universal battery, III-56, III-58
- versatile battery, II-72
- voltage indicators/monitors, II-79, IV-80, V-86
 - automotive batteries, IV-47
 - detector relay, II-76
 - HTS, I-122
 - regulator, IV-77
 - solid-state design, I-120
- watchdog circuit, V-85
- wind powered, II-70
- zapper, simple ni-cad, I-116
- Baxandall tone-control audio amp, IV-588
- BCD decoder/driver, multiplexed, VI-189
- BCD rotary switch, digital, V-160
- BCD-to-analog converter, I-160
- BCD-to-parallel converter, multiplex, I-169
- beat-frequency oscillator, VI-452
- beacon transmitter, III-683
- beep transformer, III-555, III-566
- beepers, I-19, III-49, VI-143
- bells, electronic (*see also* alarms; annunciators), I-636, II-33
- bench top power supply, II-472
- bicycle speedometer, IV-271, IV-282
- bilateral current source, III-469
- binary counter, II-135
- biomedical instrumentation
 - differential amplifier, III-282
- bipolar dc-dc converter with no inductor, II-132
- bipolar power supply, II-475
- bipolar voltage reference source, III-774
- biquad audio filter, III-185
 - second-order bandpass, III-188
 - RC active bandpass, I-285
- bird-chirp sound effect, II-588, III-677
- bird feeder monitor, V-371
- bistable multivibrators, I-133, II-465, VI-228-230, VI-418
 - inverter, III-103
 - debouncer, IV-108
 - flasher, I-299, II-234
 - lamp driver, IV-160
 - pushbutton trigger, V-388
 - RS flip-flop, I-395
 - SCR, II-367
 - SR flip-flop, IV-651
 - touch-triggered, I-133
 - trigger flip-flop, VI-229
 - two-amp flip-flop, VI-230
- bit grabber, computers, IV-105
- black light, battery-operated, V-281
- blender-motor control circuit, V-379
- blinkers (*see* flashers and blinkers)
- blown-fuse alarm, I-10
- boiler control, I-638
- bongos, electronic, II-587
- boosters
 - 12 ns, II-97
 - ac line voltage boost, V-349
 - audio, II-455, III-35, V-58
 - booster/buffer for reference current, IV-425
 - electronic, high-speed, II-96
 - forward-current, III-17
 - LED, I-307
 - power booster, op amp design, IV-358
 - rf amp, broadcast band boost, IV-487
 - shortwave FET, I-561
- bootstrap circuit, V-356
- source follower, V-20
- cable, I-34
- brake lights (*see* automotive circuits)
- brake, PWM speed control/energy recovering, III-380
- breakers
 - 12 ns, II-97
 - high-speed electronic, II-96
- breaker power dwell meter, I-102
- breakout box
 - amateur radio, VI-26-27
 - buffer, II-120,
- breath alert alcohol tester, III-359
- breath monitor, III-350
- bridge balance indicator, II-82
- bridge circuits, I-552, II-80-85, III-68-71, IV-81-83, VI-121-123
 - ac, II-81
 - ac servo amplifier with, III-387
 - accurate null/variable gain circuit, III-69
 - air-flow-sensing thermistor, IV-82
 - amplifier, 16-watt, VI-85, VI-88, VI-122, VI-123
 - auto-zeroing scale, III-69
- balance indicator, II-82
- bridge transducer amplifier, III-71
- crystal-controlled oscillator, IV-127
- differential amplifier, two op-amp, II-83
- inductance bridge, IV-83
- linearizing function circuit, VI-321
- load driver, audio circuits, III-35
- low-power common source amplifier, II-84
- one-power supply design, IV-83
- QRP SWR, III-336
- rectifier, fixed power supply, IV-398
- remote sensor loop transmitter, III-70
- rf bridge, V-50-MHz, V-303
- strain gauge signal conditioner, II-85, III-71
- transducer, amplifier for, II-84
- Wheatstone bridge, VI-123
- Wien-bridge (*see* Wien-bridge)
- brightness controls, III-308, III-316
- contrast meter, I-472, II-447
- LED, I-250
- low-loss, I-377
- broadband communications (*see* radio/rr circuits)
- buck converter, 5V/0.5A, I-494
- buck/boost converter, III-113
- buckling regulators
 - add 12-V output to 5-V, V-472
 - high-voltage, III-481
- buffer amplifiers, V-91
 - 10x, I-128
 - 100x, I-128
 - ac, single supply, I-126, VI-127
 - battery powered, standard cell, II-351
 - MOSFET design, V-93
 - sine wave output, I-126
 - VFO design, V-92
- buffers, IV-88-90, V-90-93, VI-124-128
 - amplifiers (*see* buffer amplifiers)
 - ac, single-supply, high-speed, I-127-128
 - ADC buffers, I-127, VI-125, VI-126
 - A/D, 6-bit, high-speed, I-127
 - A/D converter buffer, VI-128
 - analog noninverting switched buffer, VI-127
 - bidirectional design, VI-128
 - booster/buffer for reference current, IV-425
 - capacitance buffers
 - low-input, III-498
 - stabilized low-input, III-502
 - data/clock line serial bus for PCs, V-110
 - hex-buffer crystal oscillator, V-136
 - high-current, V-92
 - input/output, for analog multiplexers, III-11
 - inverting, II-299, IV-90
 - microphone buffer amplifier, high-Z, VI-125
 - oscillator buffers, IV-89
 - piezoelectric, VI-470
 - precision-increasing design, IV-89
 - rail-to-rail single-supply buffer, V-93
 - rf amp, buffer amp with modulator, IV-490
 - stable, high-impedance, I-128
 - unity gain, stable, good speed, high-input impedance, II-6

- buffer amplifiers, *continued*
 - VFO buffer amplifier, V-92
 - video buffer, III-712, V-93
 - voltage follower, VI-127
 - wideband buffer, I-127, VI-126
 - buffered breakout box, II-120
 - bug detector, III-365, V-150
 - bug tracer, III-358
 - bull horn, II-453, IV-31
 - burglar alarms (*see* alarms; annunciators; sirens)
 - burst generators (*see also* function generators; sound generators; waveform generators), II-86-90, III-72-74
 - multi-, square waveform, II-88
 - rf, portable, III-73
 - single timer IC square wave, II-89
 - single tone, II-87
 - strobe tone, II-90
 - tone, II-90, III-74
 - burst power control, III-362
 - bus interface, eight bit μ P, II-114
 - Butler oscillator, VI-452
 - aperiodic, I-196
 - common base, I-191
 - crystal, I-182
 - emitter follower, II-190-191, II-194
 - Butterworth filter, VI-220
 - fourth-order, I-kHz, VI-222
 - fourth order high-pass, I-280, V-179
 - fourth order low-pass, V-180
 - order low-pass, V-181
 - buzzers (*see* annunciators)
- ## C
- cable
 - bootstrapping, I-34
 - coax cable driver, VI-201
 - driver, VI-678
 - terminator, positive feedback, VI-388
 - test circuit, III-539, V-299
 - tester, audio/video cable, VI-144
 - tracers, VI-659
 - twisted-pair video driver/receiver circuit, VI-682
 - two-input video MUX cable driver, VI-197
 - video cable driver, VI-200
 - calibrated circuit, DVM auto, I-714
 - calibrators
 - analog circuits, VI-356
 - crystal, 100 kHz, I-185
 - electrolytic-capacitor reforming, IV-276
 - ESR measurer, IV-279
 - oscilloscope, II-433, III-436
 - portable, I-644
 - square wave, 5-V, I-423
 - standard for calibration, I-406
 - radio calibrator, V-298
 - tester, IV-265
 - wave shaping, high-slew rates, IV-650
 - cameras (*see* photography-related circuits; television and video)
 - canary sound simulator, V-557
 - canceller, central image, III-358
 - capacitance buffers
 - low-input, III-498
 - stabilized low-input, III-502
 - capacitance controller, digital, V-159
 - capacitance meters, I-400, II-91-94, III-75-77, VI-340
 - A/D, 3.5 digit, III-76
 - capacitance-to-voltage, II-92
 - digital, II-94
 - capacitance multiplier, I-416, II-200, V-205, V-347
 - capacitance tester, one-IC design, V-306, VI-358
 - capacitance-to-pulse width converter, II-126
 - capacitance-to-voltage meter, II-92
 - capacitor discharge
 - high-voltage generator, III-485
 - ignition system, II-103
 - capacitors
 - hysteresis compensation, V-353
 - programmable, VI-362
 - capacity tester, battery, III-66
 - car port, automatic light controller for, II-308
 - cars (*see* automotive circuits)
 - carrier-current circuits (*see also* radio/RF circuits), III-78-82, IV-91-93, V-94-96
 - AM receiver, III-81
 - audio transmitter, III-79
 - baby alert receiver/transmitter, V-95, V-96
 - data receiver, IV-93
 - data transmitter, IV-92
 - FM receiver, III-80
 - intercom, I-146
 - power line modem, III-82
 - receivers, I-141, I-143
 - IC, I-146
 - single transistor, I-145
 - relay, I-575, IV-461
 - remote control, I-146
 - transmitters, I-144
 - IC, I-145
 - on/off 200 kHz line, I-142
 - cascaded amplifier, III-13
 - cassette bias oscillator, II-426
 - cassette interface, telephone, III-618
 - centigrade thermometer, I-655, II-648, II-662
 - central image canceller, III-358
 - charge pool power supply, III-469
 - charge pumps
 - positive input/negative output, I-418, III-360
 - regulated for fixed power supply, IV-396
 - chargers (*see* battery-related circuits; chargers)
 - chase circuit, I-326, III-197
 - Chebyshev filters (*see also* filter circuits)
 - bandpass, fourth-order, III-191
 - fifth order multiple feedback low-pass, II-219
 - high-pass, fourth-order, III-191
 - chime circuit, low-cost, II-33
 - chopper circuits
 - amplifier, II-7, III-12, I-350
 - dc output, V-349
 - JFET, V-362
 - checkers (*see* measurement/test circuits)
 - chroma demodulator with RGB matrix, III-716
 - chug-chug sound generator, III-576
 - circuit breakers (*see also* protection circuits)
 - 12 ns, II-97
 - ac, III-512
 - high-speed electronic, II-96
 - trip circuit, IV-423
 - circuit protection (*see* protection circuits)
 - clamp on-current probe compensator, II-501
 - clamp limiting amplifiers, active, III-15
 - clamping circuits
 - video signal, III-726
 - video summing amplifier and, III-710
 - Clapp oscillator, VI-458
 - class-D power amplifier, III-453
 - clippers, II-394, IV-648
 - audio-powered noise, II-396
 - audio-clipper/limiter, IV-355
 - noise clipper, adjustable, VI-423
 - zener design, fast, symmetrical, IV-329
 - clock circuits, II-100-102, III-83-85, V-97-99, VI-129-131
 - 60 Hz clock pulse generator, II-102
 - adjustable TTL, I-614
 - binary clock, V-98-99
 - buffer serial bus, V-110
 - comparator, I-156
 - crystal oscillator-micropower, IV-122
 - digital, with alarm, III-84
 - gas discharge displays, II-12-hour, I-253
 - low-frequency clock, VI-131
 - oscillator/clock generator, III-85
 - phase lock, 20-MHz to NuBus, III-105
 - run-down clock for games, IV-205
 - sensor touch switch/clock, IV-591
 - set time windows within clock, VI-130
 - single op amp, III-85
 - source, clock source, I-729
 - stepper motors, V-573
 - three-phase from reference, II-101
 - TTL, wide-frequency, III-85
 - Z80 computer, II-121
 - clock generators
 - oscillator, I-615
 - precision, I-193
 - pulse generator, 60 Hz, II-102
 - clock radio, I-542, I-543
 - CMOS circuits
 - 555 astable true rail-to-rail square wave generator, II-596
 - 9 bit, III-167
 - coupler, optical, III-414
 - crystal oscillator, III-134
 - data acquisition system, II-117
 - dimmer, V-270
 - flasher, III-199
 - inverter, linear amplifier from, II-11
 - line receiver, V-497
 - mixer, I-57
 - multivibrators, V-385
 - optical coupler, III-414
 - oscillator, I-187, I-615, I-199, III-429, III-430, V-420
 - piezoelectric driver, V-440
 - programmable precision timer, III-652
 - short-pulse generator, III-523
 - touch switch, I-137
 - universal logic probe, III-499
 - variable-frequency oscillator (VFO), V-418
 - coaxial cable
 - drivers, coaxial cable, I-266, I-560
 - five-transistor pulse booster, II-191
 - test circuit, V-299
 - Cockcroft-Walton cascaded voltage doubler, IV-635

- code-practice oscillators, I-15, I-20, I-22, II-428-431, IV-373, IV-375, IV-376, V-100-103, VI-404-409
- keyer, "bug" type, V-102
- Morse code practice, V-103
- optoisolator design, V-101
- QRP sidetone generator, V-102
- single-transistor design, V-103
- VFO design, V-103
- coil drivers, current-limiting, III-173
- coin flipper circuit, III-244
- coin toss game, VI-250
- color amplifier, video, III-724
- color-bar generator, IV-814
- color organ, II-583, II-584, V-104-105, VI-193
- color video amplifier, I-34
- colorimeter, VI-306-307
- Colpitts crystal oscillators, I-194, I-572, II-147, V-411, VI-160, VI-458
- I-to-20 MHz, IV-123
- frequency checker, IV-301
- harmonic, I-189-190
- two-frequency, IV-127
- comb filter, VI-218
- combination locks, electronic, II-196
- three-dial, II-195
- commutator, four-channel, II-364
- companders (*see* compressor/expander circuits)
- comparators, I-157, II-103-112, III-86-90
- demonstration circuit, II-109
- diode feedback, I-150
- display and, II-105
- double-ended limit, II-105, I-156
- dual limit, I-151
- four-channel, III-90
- frequency, II-109, II-110, VI-353
- frequency-detecting, III-88
- high-impedance, I-157
- high input impedance window comparator, II-108
- high-low-level comparator with one op amp, II-108
- hysteresis, I-157
- inverting, I-154
- noninverting, I-153
- inverting, I-154
- jitter suppression, V-342
- latch and, III-88
- LED frequency, II-110
- limit, I-156, II-104
- low-power, less than 10 μ V
- hysteresis, II-104
- microvolt
- dual limit, III-89
- hysteresis, III-88
- monostable using, II-268
- opposite polarity input voltage, I-155
- oscillator, tunable signal, I-69
- power supply overvoltage, glitches detection with, II-107
- precision
- balanced input/variable offset, III-89
- photodiode, I-360, I-384
- time out, I-153
- TTL-compatible Schmitt trigger, II-111
- three-input and gate, op amp design, IV-363
- variable hysteresis, I-149
- voltage comparator, IV-859
- voltage monitor and, II-104
- window, I-152, I-154, II-106, III-87, III-90, III-776-781, IV-656-658, VI-181
- compass
- digital design, IV-147
- Hall-effect, III-258
- talking Hall-effect compass, V-221
- compensator, clamp-on-current probe, II-501
- composite amplifier, II-8, III-13
- composite-video signal text adder, III-716
- compressor/expander circuits, III-91-95, IV-94-97
- amplifier/compressor, low-distortion, IV-24
- audio, II-44, V-57
- audio compressor/audio-band splitter, IV-95
- clock circuit, I-156
- guitar, sound-effect circuit, IV-519
- hi-fi, II-12, II-13
- de-emphasis, III-95
- pre-emphasis, III-93
- low-voltage, III-92
- protector circuit, IV-351
- speech, II-2
- universal design, IV-96-97
- variable slope, III-94
- computalarm, I-2
- computer circuits (*see also* interfaces), II-113-122, III-96-108, V-106-110, VI-132-141
- ADC, eight-channel, for PC clones, V-29-30
- analog signal attenuator, III-101
- analog-to-digital converter for PC, VI-60
- alarm, I-2
- ASCII triplex LCD, 8048/IM80C48, II-116
- bit grabber, IV-105
- buffered breakout box, II-120
- buffer serial-bus for data/clock lines, V-110
- bus interface, 8-bit μ P, II-114
- clock phase lock, 20-MHz-to-NuBus, III-105
- CMOS data acquisition system, II-117
- contrast and backlight control, high-efficiency, VI-191
- CPU interface, one-shot, IV-239
- data acquisition circuit, VI-378
- data separator for floppy disks, II-122
- deglitcher, IV-109
- display, eight-digit, III-106
- dual 8051s execute in lock-step circuit, IV-99
- DVM adapter for PC, V-310
- EEPROM programming doubler circuit, VI-138
- EEPROM pulse generator, 5V-powered, III-99
- eight-channel mux/demux system, II-115
- eight-digit microprocessor display, III-106
- error checker, master/slave device, VI-389
- flash memory programming supply, +12 volt, VI-138
- flip-flop inverter, spare, III-103
- high-speed data acquisition system, II-118
- interface, 680x, 650x, 8080 families, III-98
- interval timer, programmable, II-678
- keyboard matrix interface, IV-240
- laptop computer power supply, V-463
- LCD, CCFL supply with variable contrast, VI-510
- line protectors, 3 μ P I/O, IV-101
- logic-level translators, IV-242
- logic line monitor, III-108
- long delay line, logic signals, III-107
- memory/protector power supply monitor, IV-425
- memory saving power supply, II-486
- microcomputer-to-triac interface, V-244
- microprocessor selected pulse width control, II-116
- modem protector circuit, V-479
- modem/fax protector for two computers, V-482
- multiple inputs detector, III-102
- one-of-eight channel transmission system, III-100
- oscilloscope digital levels, IV-108
- password protection circuit, V-109, VI-135
- power line modem for computer control, VI-474
- power saver for monitors, VI-139
- power supply for notebook computer, triple-output, VI-512
- power supply watchdog, II-494
- pulse width control, II-116
- printer error alarm, IV-106
- printer port, VI-134-135
- printer sentry, V-107-108
- reset protection, childproof, IV-107
- RGB blue box, III-99
- RS-232, computer-powered, VI-138-139
- RS-232 dataselector, automatic, III-97
- RS-232C line-driven CMOS circuits, IV-104
- RS-232-to-CMOS line receiver, III-102
- RS-232C LED circuit, III-103
- RS-422 to RS-232 converter, VI-133
- short-circuit sensor, remote data lines, IV-102
- signal attenuator, analog, III-101
- sleep-mode sound-operated circuits, V-547
- socket debugger, coprocessor, III-104
- speech synthesizer for, III-732
- stalled output detector, IV-109
- supervisory circuit, VI-136
- switch debouncer, IV-105
- auto-repeating, IV-106
- teleprinter loop supply, VI-497
- triac array driver, II-410
- voltage regulator for new microprocessors, VI-566
- Vpp generator for EPROMs, II-114
- wireless RTS keyer with data, VI-136
- XOR gates, IV-107
- up/down counter, III-105
- Z80 bus monitor/debugger, IV-103
- Z80 clock, II-121
- contact switch, I-136
- continuity testers, I-550, I-551, II-533, II-535, III-345, III-538-540, IV-287, IV-289, IV-296, VI-142-145

- buffer amplifiers, *continued*
- adjustable continuity tester, VI-144
- audible, II-536, V-317, VI-145
- audio/video cable tester, VI-144
- buzz box, I-551
- cable tester, III-539
- latching design, IV-295
- low-resistance circuits, V-319
- ohmmeter, linear, III-540
- PCB, II-342, II-535
- ratimetric, I-550
- RC decade box, V-294-295
- resistance-ratio detector, II-342
- short-circuit beeper, VI-143
- single chip checker, II-534
- visual, V-293
- contrast meters, II-447
 - automatic, I-472
 - brightness controls, I-250, I-377, III-308
- control circuits (*see* fluid and moisture; light-controlled circuits; motor control circuits; speed controllers; temperature-related circuits; tone controls)
- controller circuit, IV-142
- conversion and converters, I-503, II-123-132, III-109-122, IV-110-120, V-116-128, VI-146-155
 - 3-to-5 V regulated output, III-739
 - 4-to-18 MHz, III-114
 - 4-to-20 mA current loop, IV-111
 - 5V-to-isolated 5V at 20 MA, III-474
 - 5V-to-0.5A buck, I-494
 - 9-to-5 V converter, IV-119
 - 12-to-9 V, 7.5, or 6 V, I-508
 - 12-to-16 V, III-747
 - 28-to-5 Vdc converter, V-127
 - 50+ V feed forward switch mode, I-495
 - 50+ V push-pull switched mode, I-494
 - 100 MHz, II-130
 - 100 V-to-10.25 A switch mode, I-501
 - 225-W 15-V output converter, VI-148-149
 - 800-to-1000 MHz scanner converter, V-122
- ac-to-dc converters, I-165
 - fixed power supplies, IV-395
 - full-wave, IV-120
 - high-impedance precision rectifier, I-164
- amateur TV downconverter, 420 to 450 MHz, VI-44-45
- amateur TV downconverter, 902 to 928 MHz, VI-40-41
- analog-to-digital (*see* analog-to-digital conversion)
- ATV downconverter, V-125, V-126
- ATV rf receiver/converter, IV-420
- BCD-to-analog, I-160
- BCD-to-parallel, multiplexed, I-169
- buck/boost, III-113
- calculator-to-stopwatch, I-153
- capacitance-to-pulse width, II-126
- crystal-controlled, one-chip, V-117
- current-to-frequency, IV-113
 - wide-range, I-164
- current-to-voltage, I-162, I-165, V-127, VI-154, VI-155
 - grounded bias and sensor, II-126
 - photodiode, II-128
- dc automobile power adapter, V-70
- dc-to-dc, IV-118, V-119, V-128, VI-164-167
 - 1-to-5 V, IV-119
 - 3-to-5 V battery, IV-119
 - 3-to-25 V, III-744, IV-118
 - bipolar, no inductor, II-132
 - fixed 3- to 15-V supply, IV-400
 - isolated +15V, III-115
 - push-pull, 400 V/60 W, I-210
 - regulating, I-210, I-211, II-125, III-121
 - step-up/step-down, III-118
 - dc/ac inverter, V-669
 - dc/dc converter, V-669
 - differential voltage-to-current converter, VI-153
 - digital-to-analog (*see* digital-to-analog conversion)
 - direct-conversion 7-MHz receiver, VI-153
 - driven flyback converter, VI-150
 - fixed power supply, III-470
 - flyback, I-211
 - self oscillating, I-170, II-128, III-748
 - voltage, high-efficiency, III-744
 - frequency, I-159, V-123
 - frequency-to-voltage (*see* frequency-to-voltage conversion)
 - HF receive converter, VI-147
 - high-to-low-impedance, I-41
 - intermittent converter, power saver, IV-112
 - IR-pulse-to-audio converter, V-224
 - light intensity-to-frequency, I-167
 - line-voltage-to-multimeter adapter, V-312
 - logarithmic
 - fast-action, I-169
 - temperature-compensated, V-127
 - low-frequency, III-111, VI-153
 - ohms-to-volts, I-168
 - oscilloscope, I-471
 - output-to-current converter, VI-155
 - NTSC-to-RGB converter, VI-677
 - period-to-voltage, IV-115
 - photodiode log converter/transmitter, VI-312
 - pico-ampere, 70 V with gain, I-170
 - PIN photodiode-to-frequency, III-120
 - polar-to-rectangular converter/pattern generator, V-288
 - polarity, I-166
 - positive-to-negative, III-112, III-113
 - power supplies, inductorless, V-456
 - pulse height-to-width, III-119
 - pulse train-to-sinusoid, III-122
 - pulse width-to-voltage, III-117
 - radio beacon converter, IV-495
 - rectangle-to-triangle waveform, IV-118-117
 - regulated 15-V_{out} 6-V driven, III-745
 - resistance-to-voltage, I-161-162
 - rf converters, IV-494-501
 - ATV receiver/converter, 420 MHz, low-noise, IV-496, IV-497
 - radio beacon converter, IV-495
 - receiver frequency-converter stage, IV-499
 - SW converter for AM car radio, IV-500
 - two-meter, IV-498
 - up-converter, TVRO subcarrier reception, IV-501
 - VLF converter, IV-497
 - WWW-to-SW converter, IV-499
 - receiving converter, 220 MHz, IV-500
- RGB-composite video signals, III-714
- RMS-to-dc, I-167, II-129
 - 50-MHz thermal, III-117
- RGB-to-NTSC, IV-611
- sawtooth wave converter, IV-114
- scanner converter, V-800-to-1000 MHz, V-122
- SCR converter, VI-151
- shortwave, III-114, V-118
- simple LF, I-546
- sine-wave converter, VI-150
- sine-to-square wave, I-170, IV-120, V-124, V-125, V-569, V-570
- square-to-sine wave, III-118
- square-to-triangle wave, TTL, II-123
- step-down converter, 5-V 5-A, VI-151
- sync-to-async, VI-152
- temperature-to-digital, V-123, VI-646
- temperature-to-frequency, I-168, V-121, VI-639
- temperature-to-time, III-632-633
- transverter, V-2-to-6 meter, V-124
- triangle-to-sine wave, II-127
- TTL-to-MOS logic, II-125, I-170
- two-wire to four-wire audio, II-14
- unipolar-to-dual voltage supply, III-743
- video converters
 - a/d and d/a, IV-610-611
 - RGB-to-NTSC, IV-611
- VLF converters, I-547, V-121
 - rf converter, IV-497
 - voltage (*see* voltage converters)
- voltage multipliers, V-668-669
- WWV converter, V-119, VI-147
- WWV-to-SW rf converter, IV-193
- cool-down circuit, V-354, V-357
- coprocessor socket debugger, III-104
- countdown timer, II-680
- counters (*see also* dividers), II-133-139, III-123-130, V-129-133
 - analog circuit, II-137
 - attendance, II-138
 - binary, II-135
 - divide-by-N
 - 1+ GHz, IV-155
 - 1.5+ divide-by-n, IV-156
 - CMOS programmable, I-257
 - 7490-divided-by-n, IV-154
 - divide-by-odd number, IV-153
 - event counter, VI-369
 - frequency counters, VI-360
 - 2 MHz, V-130-131
 - 10 MHz, V-132-133
 - preamp, V-24
- frequency dividers, I-258, II-251, II-254, III-213-218, III-340, III-768
 - 1.2 GHz, III-129
 - 10-MHz, III-126
 - clock input, IV-151
 - decade, I-259
 - divide-by-1.5, III-216
 - low-cost, III-124
 - low-frequency, II-253
 - preamp, III-128
 - programmable, IV-152-153
 - staircase generator and, I-730
 - tachometer and, I-310
- fringe counter, VI-300
- Geiger, I-536-537, V-217-219
- microfarad counter, IV-275
- minimum/maximum selector, four-input, V-332

- odd-number divider and, III-217
- preamplifier, oscilloscope, III-438
- precision frequency, I-253
- programmable, low-power wide-range, III-126
- ring counters
 - 20 kHz, II-135
 - low-cost, I-301
 - low-power pulse circuit, IV-437
 - SCR, III-195
 - variable timing, II-134
- time base, function generators, I Hz, IV-201
- universal
 - 10-MHz, I-255, II-139
 - 40-MHz, III-127
- up/down counters
 - 8-digit, II-134
 - extreme count freezer, III-125
 - XOR gate, III-105
- coupler circuits
 - linear couplers
 - ac analog, II-412
 - analog, II-413
 - dc, II-411
 - optocoupler, instrumentation, II-417
 - optical couplers/optocouplers, V-407
 - CMOS design, III-414
 - interface circuits, V-406-407
 - linear, instrumentation, II-417
 - stable, II-409
 - TTL design, III-416
 - photon, II-412
 - RF line sampler/coupler, VI-30
 - transmitter oscilloscope for CB signals, I-473
- courtesy lights (*see* automotive circuits)
- craps game, VI-245
- CRO doubler, III-439
- cross fader, II-312
- cross-hatch generator, color TV, III-724
- crossover networks, II-35
 - 5V, I-518
 - ac/dc lines, electronic, I-515
 - active, I-172
 - asymmetrical third order
 - Butterworth, I-173
 - electronic circuit for, II-36
- crowbars, I-516
 - electric, III-510
 - electronic, II-99
 - SCR, II-496
 - voltage regulator, variable, with crowbar limiting, VI-515
- crystal oscillators (*see also* oscillators), I-180, I-183-185, I-195, I-198, II-140-151, III-131-140, IV-121-128, V-134-140, VI-156-160
 - 1-to-20 MHz, TTL design, IV-127
 - 1-to-4 MHz, CMOS design, IV-125
 - 10 MHz, II-141
 - 10-to-150 kHz, IV-125
 - 10-to-80 MHz, IV-125
 - 50-to-150 MHz, IV-126
 - 96 MHz, I-179
 - 150-to-30,000 kHz, IV-126
 - 330 MHz, IV-125
 - activity tester, V-138
 - amplifier, tuned, VI-57
 - aperiodic, parallel-mode, I-196
 - basic design, V-135
 - bridge, crystal-controlled, IV-127
 - Butler oscillator, I-182
 - calibrator, 100 kHz, I-185, IV-124
 - ceramic, 10 MHz, varactor tuned, II-141
 - clock, micropower design, IV-122
 - CMOS crystal oscillators, I-187, III-134
 - 1-to-4 MHz, IV-125
 - Colpitts crystal oscillators, I-194, I-572, II-147, VI-160
 - 1-to-20 MHz, IV-123
 - frequency checker, IV-301
 - harmonic, I-189-190
 - two-frequency, IV-127
 - crystal-controlled oscillator as, II-147
 - crystal-stabilized IC timer for subharmonic frequencies, II-151
 - crystal tester, I-178, I-186, II-151
 - de-switched, VI-159
 - doubler and, I-184
 - easy start-up, III-132
 - FET, 1 MHz, II-144
 - FET quartz crystal oscillator, VI-157
 - FET VXO, VI-157
 - FM capable, VI-158
 - frequency adjustable, VI-159
 - frequency doubler, VI-160
 - fundamental-frequency, III-132
 - Hartley oscillator, V-140
 - hex-buffer, V-136
 - high-frequency, I-175, II-148
 - high-frequency signal generator as, II-150
 - IC-compatible, II-145
 - impedance checker, V-136
 - LO for SSB transmitter controlled by, II-142
 - low-frequency, I-184, II-146, V-135
 - 10 kHz to 150 kHz, II-146
 - low-noise, II-145
 - marker generator, III-138
 - mercury cell crystal-controlled oscillator as, II-149
 - OF-1 HI oscillator, international, I-197
 - OF-1 LO oscillator, international, I-189
 - overtone oscillators, I-176, I-177, I-180, I-183, I-186, II-146, III-146
 - 50 MHz to 100 MHz, I-181
 - 100 MHz, IV-124
 - crystal, I-176, I-180, II-146
 - crystal switching, I-183
 - fifth-overtone, I-182
 - third-overtone oscillator, IV-123
- Pierce oscillator, V-140
 - 1-MHz, III-134
 - crystal, I-195, II-144
 - harmonic, I-199, II-192
 - JFET, I-198
 - low-frequency, III-133
 - quartz, two-gate, III-136
 - radio detector, VI-182
 - reflection oscillator, crystal-controlled, III-136
 - Schmitt trigger, I-181
 - signal source controlled by, II-143
 - sine-wave oscillator, I-198
 - stable low-frequency, I-198
 - standard, 1 MHz, I-197
 - temperature-compensated, I-187, II-142, III-137
 - test circuit, V-139
 - third-overtone, I-186, IV-123
 - time base, III-133, IV-128, V-137, V-138
 - TTL design, I-179, IV-127
 - TTL-compatible, I-197
 - transistorized, I-188
 - tube-type, I-192
 - UJT 100-kHz calibration oscillator, VI-157
 - VHF crystal oscillator, III-138-140
 - voltage-controlled (VCO), III-135, IV-124
 - wide-range, V-139
 - crystal radio receiver, VI-549, VI-557
 - crystal switching, overtone oscillator with, I-183
 - current analyzer, auto battery, I-104
 - current booster, I-30, I-35
 - current collector head amplifier, II-11, II-295
 - current feedback amp, 100 mA at 100 MHz, V-25
 - current limiter, V-146
 - foldback current, VI-477
 - inrush current, V-358
 - regulator, VI-478
 - current loops
 - 4-to-20-mA converter, IV-111
 - controller, SCR design, IV-387
 - current meters and monitors, I-203, II-152-157, III-255, III-338, IV-284, V-144-146, VI-259, VI-355
 - alarm and current monitor, III-338
 - ac current indicator, IV-290
 - current sensing in supply rails, II-153
 - electrometer amplifier with overload protection, II-155
 - Hall-effect sensors, III-255, IV-284
 - high-gain current sensor, IV-291
 - line-current monitor, III-341
 - picoammeter, I-202, II-154, II-157, III-338
 - guarded input, II-156
 - range ammeter, six-decade, II-153, II-156
 - current probe, VI-521
 - current readout, rf, I-22
 - current regulators, op amp, VI-430, VI-489
 - current sensing, supply rails, II-153
 - current sink, I-206
 - 1 mA for fixed power supplies, IV-402
 - voltage-controlled, IV-629
 - current sources, I-205, I-697, V-141-143, VI-161-163, VI-332, VI-335
 - 0-to-200-nA, IV-327
 - bilateral, I-694-695, III-469, V-143
 - bipolar sources
 - inverting, I-697
 - noninverting, I-695
 - constant, I-697, III-472
 - fixed power supplies
 - bootstrapped amp, IV-406
 - differential-input, fast-acting, IV-405
 - low-current source, IV-399
 - generator, VI-162
 - limiter, V-146
 - low-resistance measurements, V-142
 - multiple fixed current source, VI-163
 - negative, V-143
 - offset-adjusting, V-145
 - positive, V-142
 - precision, I-205, I-206

- current sources, *continued*
 regulator, variable power supply, III-490
 variable power supplies, voltage-programmable, IV-420
 voltage-controlled, III-468, VI-162, VI-163
 current-limiting regulator, V-458
 current-shunt amplifiers, III-21
 current-to-frequency converter, IV-113
 wide range, I-164
 current-to-voltage amplifier, high-speed, I-35
 current-to-voltage converter, I-162, I-165, V-127, VI-154, VI-155
 grounded bias and sensor in, II-126
 photodiode, II-128
 curve tracer, V-300
 diodes, IV-274
 FET, I-397
 CW-related circuits
 audio filter, VI-29, VI-405
 CW/SSB receiver, 80- and 40-meter, V-499
 filter, razor sharp, II-219
 identifier, VI-24, VI-408
 keying circuits, IV-244
 offset indicator, IV-213
 SSB/CW product detector, IV-139
 transceiver, 5 W, 80-meter, IV-602
 transmitters
 1-W, III-678
 6-W 40-M, VI-664
 20-M low-power, V-649
 40-M, III-684, V-648
 902-MHz, III-686
 HF low-power, IV-601
 keying circuit, VI-22-23
 one-watt, VI-27
 QRP, III-69
 ultrasonic transceiver, VI-669
 cyclic A/D converter, II-30
- D**
- dark-activated (*see* light-controlled circuits)
 darkroom equipment (*see* photography-related circuits)
 Darlington amplifier, push-pull, V-22
 Darlington regulator, variable power supplies, IV-421
 Darlington transistor oscillator, VI-455
 data-manipulation circuits, IV-129-133
 acquisition circuits, IV-131, VI-378
 CMOS system, II-117
 four-channel, I-421
 high-speed system, II-118
 analog-signal transmission isolator, IV-133
 link, IR type, I-341
 prescaler, low-frequency, IV-132
 read-type circuit, 5 MHz, phase-encoded, II-365
 receiver, carrier-current circuit design, IV-93
 receiver/message demuxer, three-wire, IV-130
 selector, RS-232, III-97
 separator, floppy disk, II-122
 transmission circuits, IV-92
 dc adapter/transceiver, hand-held, III-461
 dc generators, high-voltage, III-481
 dc motors (*see also* motor control circuits)
 direction control, I-452
 driver controls
 fiberoptic control, II-206
 fixed speed, III-387
 servo, bipolar, II-385
 reversible, II-381, III-388
 speed control, I-452, I-454, III-377, III-380, III-388
 dc restorer, video, III-723
 dc servo drive, bipolar control input, II-385
 dc static switch, II-367
 dc-to-ac inverter, V-247, V-669
 dc-to-dc conversion, IV-118, V-669, VI-164-167
 1-to-5 V, IV-119
 3-to-5 V battery, IV-119
 3-to-25 V, III-744, IV-118
 3.3- and 5-V outputs, V-128
 3 A, no heatsink, V-119
 bipolar, no inductor, II-132
 fixed 3- to 15-V supply, IV-400
 isolated, VI-165
 isolated +15V, III-115
 negative step-up converter, VI-166
 push-pull, 400 W/60 W, I-210
 regulating, I-210, I-211, II-125, III-121
 step-up/step-down, III-118
 ultra low-power for personal communications, VI-166
 dc-to-dc inverter, VI-285
 dc-to-dc SMPDS variable power supply, II-480
 debouncers, III-592, IV-105, V-316, VI-387, VI-613, VI-614
 auto-repeat, IV-106
 computer applications, IV-105, IV-106, IV-108
 flip-flop, IV-108
 debugger, coprocessor sockets, III-104
 decibel level detector, audio, with meter driver, III-154
 decoders, II-162, III-141-145, VI-168-171
 10.8 MHz FSK, I-214
 24-percent bandwidth tone, I-215
 BCD decoder/driver, multiplexed, VI-189
 direction detector, III-144
 DTMF decoder, VI-169
 dual-tone, I-215
 encoder and, III-144
 FM stereo decoder, VI-170
 frequency division multiplex stereo, II-169
 PAL/NTSC, with RGB input, III-717
 radio control receiver, I-574
 SCA, I-214, III-166, III-170
 second-audio program adapter, III-142
 sound-activated, III-145
 stereo TV, II-167
 time division multiplex stereo, II-168
 tone alert, I-213
 tone dial, I-630, I-631
 tone decoders, I-231, III-143, VI-170
 24% bandwidth, I-215
 dual time constant, II-166
 relay output, I-213
 tone-dial decoder, I-630, I-631
 video, NTSC-to-RGB, IV-613
 video line decoders, VI-171
 weather-alert detector/decoder, IV-140
 deglitcher circuit, IV-109, V-336-337
 delay circuits/ delay units, III-146-148, V-147-148, VI-172-173
 adjustable, III-148
 analog delay line, echo and reverb effects, IV-21
 door chimes, I-218
 echo and reverb effects, analog delay line, IV-21
 exit delay for burglar alarm, V-10
 headlights, I-107, II-59
 leading-edge, III-147
 long duration time, I-217, I-220
 power-on delay, V-148
 precision solid state, I-664
 pulse, dual-edge trigger, III-147
 pulse generator, II-509
 relay, ultra-precise long time, II-211
 timed delay, I-608, II-220
 time-delay generator, VI-173
 constant-current charging, II-668
 windshield wiper delay, I-97, II-55
 demodulators, II-158-160, III-149-150
 5V FM, I-233
 12V FM, I-233
 565 SCA, III-150
 AM demodulator, II-160
 chroma, with RGB matrix, III-716
 FM demodulator, I-544, II-161, V-151, V-155
 narrow-band, carrier detect, II-159
 linear variable differential transformer driver, I-403
 LVDT demodulators, II-337, III-323-324
 stereo, II-159
 telemetry, I-229
 demonstration comparator circuit, II-109
 demultiplexers (*see also* multiplexers), III-394
 differential, I-425
 eight-channel, I-426, II-115
 descramblers, II-162
 gated pulse, II-165
 outband, II-164
 sine wave, II-163
 derived center-channel stereo system, IV-23
 detect-and-hold circuit, peak, I-585
 detectors (*see* fluid and moisture; light-controlled circuits; motion and proximity; motor control circuits; peak detectors; smoke detectors; speed controllers; temperature-related circuits; tone controls; zero-crossing)
 deviation meter, IV-303
 dial pulse indicator, telephone, III-613
 dialers, telephone
 pulse-dialing telephone, III-610
 pulse/tone, single-chip, III-603
 telephone-line powered repertory, I-633
 tone-dialing telephone, III-607
 dice, electronic, I-325, III-245, IV-207
 differential amplifiers, I-38, III-14, V-18, V-21, VI-185-287
 high-impedance, I-27, I-354
 high-input high-impedance, II-19

instrumentation, I-347, III-283
 instrumentation, biomedical, III-282
 oscilloscopes, VI-463
 programmable gain, III-507
 two op amp bridge type, II-83
 wide input common-mode range, VI-53
 differential analog switch, I-622
 differential capacitance measurement circuit, II-665
 differential hold, I-589, II-365
 differential multiplexers
 demultiplexer/, I-425
 wide band, I-428
 differential thermometer, II-661, III-638
 differential voltage or current alarm, II-3
 differentiators, I-423, V-347
 negative-edge, I-419
 positive-edge, I-420
 digital-capacitance meter, II-94
 digital-IC, tone probe for testing, II-504
 digital-frequency meter, III-344
 digital-logic probe, III-497
 digital audio tape (DAT), ditherizing circuit, IV-23
 digital circuits, V-156-160
 audio selector, V-158
 BCD rotary switch, V-160
 capacitance control, V-159
 entry lock, V-157
 inverters, V-246
 potentiometer control, V-158
 resistance control, V-159
 digital multimeter (DMM), IV-291, V-291
 digital voltmeters (DVM), III-4
 3.5-digit, I-713, III-761
 3.75-digit, I-711
 4.5-digit, I-717, III-760
 auto-calibrate circuit, I-714
 automatic nulling, I-712
 calibrated circuit, DVM auto, I-714
 interface and temperature sensor, II-647
 LED readout, IV-286
 digital-to-analog converters, I-241, II-179-181, III-163-169, V-120
 0-to -5V output, resistor terminated, I-239
 3-digit, BCD, I-239
 8-bit, I-240-241
 high-speed, I-240
 output current to voltage, I-243 to 12-bit, two, II-180
 9-bit, CMOS, III-167
 10-bit, I-238
 4-quad, offset binary coding, multiplying, I-241
 +10V full scale bipolar, I-242
 +10V full scale unipolar, I-244
 12-bit
 binary two's complement, III-166
 DAC, VI-149
 precision, I-242
 variable step size, II-181
 14-bit binary, I-237
 16-bit binary, I-243
 fast voltage output, I-238
 high-speed voltage output, I-244
 multiplying, III-168
 octal converter, V-350
 output amplifier, four-channel, III-165
 video converter, IV-610-611
 digitizer, tilt meter, III-644-646
 dimmer switches, I-369, II-309, IV-247, IV-249, VI-377
 800 W, II-309
 dc lamp, II-307
 four-quadrant, IV-248-249
 halogen lamps, III-300
 headlight, II-57, II-63
 low-cost, I-373
 soft-start, 800-W, I-376, III-304
 tandem, II-312
 triac, I-375, II-310, III-303
 diode emitter driver, pulsed infrared, II-292
 diode tester, I-402, II-343, III-402
 go/no-go, I-401
 zener diodes, I-406
 diode-matching circuit, IV-280
 dip meters, I-247, II-182-183
 basic grid, I-247
 dual gate IGFET, I-246
 little dipper, II-183
 varicap tuned FET, I-246
 diplexer/mixer, IV-335
 direction detectors/finders, IV-146-149
 compasses
 digital design, IV-147
 Hall effect, III-258
 talking Hall effect, V-221
 decoder, III-144
 directional-signals monitor, auto, III-48
 optical direction discriminator, V-408
 thermally operated, IV-135
 radio-signal direction finder, IV-148-149
 direction-of-rotation circuit, III-335
 directional-signals monitor, auto, III-48
 disco strobe light, II-610
 discrete current booster, II-30
 discrete sequence oscillator, III-421
 discriminators
 multiple-aperture, window, III-781
 pulse amplitude, III-356
 pulse width, II-227
 window, III-776-781
 display circuits, II-184-188, III-170-171, V-161-167, VI-188-195
 $3\frac{1}{2}$ digit DVM common anode, II-713
 60 dB dot mode, II-252
 audio, LED bar peak program meter, II-254
 bar-graph indicator, ac signals, II-187
 bar-graph level gauge, VI-192
 bar-graph room temperature, VI-641
 BCD decoder/driver, multiplexed, VI-189
 brightness control, III-316
 cascaded counter/display driver, V-163
 color organ, VI-193
 color shifting LED display, VI-189
 common cathode, 4033-based, V-162
 common-anode, V-167
 comparator and, II-105
 contrast and backlight control, high-efficiency, VI-191
 exclamation point, II-254
 expanded scale meter, dot or bar, II-186
 fluorescent tube, V-167
 gas-discharge tube, V-167
 LCD
 7-segment, V-165
 contrast temperature compensator, VI-195
 large-size, V-164
 LED
 7-segment, V-166
 audio, peak program meter, II-254
 bargraph driver, VI-195
 Christmas lights, VI-225
 common-cathode, V-167
 driver, II-188
 leading-zero suppressed, V-165
 two-variable, III-171
 oscilloscope, eight-channel voltage, II-435
 stereo level display, VI-190
 voice level meter, VI-194
 dissolver, lamp, solid-state, III-304
 distribution circuits, II-35
 distribution amplifiers
 audio, I-39, II-39, V-59
 signal, I-39
 ditherizer, VI-377
 dividers, IV-150-156
 binary chain, I-258
 divide-by-2-or-3 circuit, IV-154
 divide-by-N
 1+ GHz, IV-155
 1.5+ divide-by-n, IV-156
 CMOS programmable, I-257
 7490-divided-by-n, IV-154
 divide-by-odd number, IV-153
 frequency dividers, I-258, II-251, II-254, III-213-218, III-340, III-768, V-343
 1.2 GHz, III-129
 10-MHz, III-126
 clock input, IV-151
 decade, I-259
 divide-by-1.5, III-216
 low-cost, III-124
 low-frequency, II-253
 preamp, III-128
 programmable, IV-152-153
 staircase generator and, I-730
 tachometer and, I-310
 mathematical, one trim, III-326
 multiplier/divider, one-quadrant, VI-318
 multiplier/divider, variable analog, VI-322
 odd-number counter and, III-217
 pulse, non-integer programmable, II-511, III-226
 Dolby noise reduction circuits, III-399, VI-421
 decode mode, III-401
 encode mode, III-400
 doorbells/chimes (*see* annunciators)
 door-open alarm, II-284, III-46, III-256
 door opener, III-366
 door ringer security circuit, V-5
 dot-expanded scale meter, II-186
 double-sideband suppressed-carrier modulator, III-377
 rf, II-366
 doublers
 0 to 1 MHz, II-252
 150 to 300 MHz, I-314
 audio-frequency doubler, IV-16-17

- doublers, *continued*
 - broadband frequency, I-313
 - CRO, oscilloscope, III-439
 - crystal oscillator, I-184
 - EEPROM programming doubler circuit, VI-138
 - frequency, I-313, III-215, VI-369, VI-160
 - broadband, I-313
 - digital, III-216
 - GASFET design, IV-324
 - single-chip, III-218
 - low-frequency, I-314
 - voltage doublers, III-459, IV-635
 - cascaded, Cockcroft-Walton, IV-635
 - triac-controlled, III-468
 - downbeat-emphasized metronome, III-353-354
 - downconverter, ATV, VI-40-41, VI-44-45
 - drivers and drive circuits, I-260, II-189-193, III-172-175, IV-157-160, VI-196-202
 - 50 ohm, I-262
 - alarm driver, high-power, V-2
 - bar-graph driver
 - LED, II-188
 - transistorized, IV-213
 - BCD decoder/driver, multiplexed, VI-189
 - BIFET cable, I-264
 - bridge loads, audio circuits, III-35
 - cable driver, VI-678
 - capacitive load, I-263
 - Christmas lights driver, IV-254
 - coaxial cable, I-266, I-560, VI-201
 - five-transistor pulse boost, II-191
 - coil, current-limiting, III-173
 - CRT deflection yoke, I-265
 - demodulator, linear variable differential transformer, I-403
 - diode-emitter driver, II-292
 - FET driver, IV-241
 - fiberoptic, 50-Mb/s, III-178
 - flash slave, I-483
 - glow-plug, II-52
 - high-impedance meter, I-265
 - high-impedance relay driver, VI-570
 - indicator lamp driver, III-413
 - instrumentation meter, II-296
 - lamp drivers, I-380
 - flip-flop independent design, IV-160
 - low-frequency flasher/relay, I-300
 - optical coupling, III-413
 - neon lamps, I-379
 - short-circuit-proof, II-310
 - laser driver
 - high speed, I-263
 - IC-based, VI-296
 - op-amp circuit, VI-295
 - pulsed double-heterostructure laser, VI-296
 - single heterostructure diode, VI-290
 - latching relay driver, VI-571
 - LED drivers
 - bar graph, II-188, VI-195
 - emitter/follower, IV-159
 - line drivers, I-262
 - 50-ohm transmission, II-192
 - 600-ohm balanced, II-192
 - audio, V-54
 - impedance-matched with 75 Ohm load, VI-197
 - low-distortion composite 100mA, VI-200
 - line-synchronized, III-174
 - load drivers
 - audio, III-35
 - timing threshold, III-648
 - LVDT demodulator and, II-337, III-323-324
 - meter drivers, II-296
 - rf amplifier, I-MHz, III-545
 - microprocessor triac array, II-410
 - MOSFET driver
 - current booster, VI-368
 - high-side, VI-199
 - motor drivers (*see* motor control, drivers)
 - multiplexer, high-speed line, I-264
 - neon lamp, I-379, VI-198
 - op amp power driver, IV-158-159
 - optoisolated, high-voltage, III-482
 - piezoelectric driver, V-440, VI-470
 - 555 oscillator, V-441
 - CMOS, V-440
 - micropositioner, V-440
 - full rail excursions in, II-190
 - high-output 600-ohm, II-193
 - synchronized, III-174
 - video amplifier, III-710
 - power driver, op amp, IV-158-159
 - pulse echo driver, VI-380
 - pulsed infrared diode emitter, II-292
 - relay, I-264
 - delay and controls closure time, II-530
 - low-frequency, I-300
 - with strobe, I-266
 - RIAA line amplifier/driver, VI-77
 - rf drivers, low-distortion, II-538
 - RS-232C, low-power, III-175
 - shield/line driver, high-speed, VI-198
 - shift register, I-418
 - solenoid, I-265, III-571-573, VI-202
 - SSB, low-distortion 1.6 to 30 MHz, II-538
 - stepping motor, II-376, III-390, IV-349, IV-350
 - stereo line driver, VI-198
 - test driver for hobby servos, VI-197
 - three-phase motor driver, II-383
 - totem-pole, with bootstrapping, III-175
 - transformer driver, I-403
 - transistor relay driver, VI-571
 - triac array driver, II-410
 - twisted-pair video driver/receiver circuit, VI-682
 - two-input video MUX cable driver, VI-197
 - two-phase motor driver, I-456, II-382
 - ultra low distortion 50-mA driver, VI-201
 - VCO driver, op-amp design, IV-362
 - video driver, VI-683
 - video cable driver, VI-200
 - drop-voltage recovery for long-line systems, IV-328
 - drum sound effect, II-591
 - DTMF decoder, VI-169
 - dual-tone decoding, II-620
 - dual-tracking regulator, III-462
 - duplex line amplifier, telephone, III-616
 - duty-cycle related circuits
 - 555 circuit, VI-446
 - detector, IV-144
 - meter, IV-275
 - monitor, III-329
 - multivibrator, 50-percent, III-584
 - oscillators, VI-438, VI-446
 - 50-percent, III-426
 - variable, fixed-frequency, III-422
 - DVM adapter for PC, V-310
 - dwel meters
 - breaker point, I-102
 - digital, III-45
- ## E
- ear protector, V-482
 - eavesdropper, telephone, wireless, III-620
 - ECG amplifiers with right leg drive, VI-354
 - echo effect, analog delay line, IV-21
 - edge detector, I-266, III-157
 - EEPROM pulse generator, 5V-powered, III-99
 - EKG simulator, three-chip, III-350
 - elapsed-time timer, II-680
 - electric-fence charger, II-202
 - electric-vehicle battery saver, III-67
 - electrolytic-capacitor reforming circuit, IV-276
 - electromagnetic-field sensor, V-308
 - electrometer, IV-277
 - amplifier, overload protected, II-155
 - electroscope, VI-341
 - ion-sensing, VI-287
 - electrostatic detector, III-337
 - EI.F monitor, VI-336
 - emergency lights, I-308, I-378, IV-250
 - emissions analyzer, automotive exhaust, II-51
 - emitter follower circuit, complementary/bilateral ac, V-353
 - emulators, II-198-200
 - capacitance multiplier, II-200
 - JFET ac coupled integrator, II-200
 - resistor multiplier, II-199
 - simulated inductor, II-199
 - encoders
 - decoder and, III-14
 - telephone handset tone dial, I-634, III-613
 - tone encoders, I-67, I-629
 - two-wire, II-364
 - two-tone, V-629
 - enlarger timer, II-446, III-445
 - envelope detectors, III-155
 - AM signals, IV-142
 - full-wave, V-152
 - low-level diodes, IV-141
 - envelope generator/modulator, musical, IV-22
 - EPROM, Vpp generator for, II-114
 - equalizers, I-671, IV-18
 - octave equalizer, V-353
 - ten-band, graphic, active filter in, II-684
 - ten-band, octave, III-658
 - video equalizers, VI-681
 - equipment-on reminder, I-121
 - error checker, master/slave device, VI-389
 - event counter, VI-369
 - exhaust emissions analyzer, II-51
 - exit delay for burglar alarms, V-10
 - expanded-scale meters

analog, III-774
dot or bar, II-186
expander circuits (*see*
compressor/expander circuits)
experimenter's power source, VI-507,
VI-511
extended-play circuit, tape-
recorders, III-600
extractor, square-wave pulse, III-
584

F

555 timer circuits (*see also* timers)
alarm based on 555 timer, V-11
astable, low-duty cycle, II-267
beep transformer, III-566
dual flasher, VI-225
duty cycle oscillator, VI-446
FM modulator, V-367
integrator to multiply, II-669
missing-pulse detector, V-152
monostable multivibrator, VI-700
output indicator, LED, VI-260
ramp generator, V-203
RC audio oscillator from, II-567
square wave generator using, II-595
fader circuits, II-42, II-312, IV-17, V-
658
fail-safe semiconductor alarm, III-6
fans
infrared heat-controlled fan, IV-226
speed controller, automatic, III-382
thermostatic switch, V-68
Fahrenheit thermometer, I-658
fault monitor, single-supply, III-495
fax circuits, V-171-173
modern/fax protector for two
computers, V-482
fax/telephone switch, remote-
controlled, IV-552-553
feedback oscillator, I-67
fence chargers, II-201-203
battery-powered, II-202
electric, II-202
solid-state, II-203
FET circuits
amplifier, offset gate bias, V-22
crystal oscillators, VI-157
dc controlled switch, V-592
hexFET switch, V-592, V-593
dual-trace-scope switch, II-432
input amplifier, II-7
microphone mixer, V-363, V-364
preamp for phono cartridge, VI-79
probe, III-501
voltmeter, III-765, III-770
fiber optics, II-204-207, III-176-181,
VI-206-207
data receiver, VI-207
data transmitter, VI-207
driver, LED, 50-Mb/s, III-178
interface for, II-207
LED lightwave communications
receiver, VI-310
LED lightwave communications
transmitter, VI-309
link, I-268, I-269, I-270, III-179
motor control, dc, II-206
receivers
10 MHz, II-205
50-Mb/s, III-181
digital, III-178
high-sensitivity, I-270
low-cost, 100-M baud rate, III-180
low-sensitivity, I-271
very-high-sensitivity, low-
speed, 3nW, I-269
repeater, I-270
speed control, II-206
transmitter, III-177
field disturbance sensor/alarm, II-507
field-strength meters, II-208-212, III-
182-183, IV-164-166, V-174-176
1.5-150 MHz, I-275
adjustable sensitivity indicator, I-
274
amplified field, V-175
high-sensitivity, II-211
LF or HF, II-212
microwave, low-cost, I-273
remote, V-175
rf sniffer, II-210
sensitive, I-274, III-183
signal-strength meter, IV-166
simple design, three versions, V-176
transmission indicator, II-211
tuned, I-276
UHF fields, IV-165
untuned, I-276
filter circuits, II-213-224, III-184-192,
IV-167-177, V-177-191, VI-208-
222
active (*see* active filters)
analog, programmable, VI-215
antialiasing/sync-compensation, IV-
173
audio filters
biquad, I-292-293, III-185
tunable, IV-169
audio range filter, V-190
bandpass (*see* bandpass filters)
bandpass amplifier, VI-54
band-reject, active, II-401
biquad, I-292-293
audio, I-292-293, III-185
RC active bandpass, I-285, V-190
bridge filter, twin-T, programmable,
II-221
Butterworth
active, VI-220
fourth-order, 1-kHz, VI-222
high-pass, fourth-order, I-280,
V-179
low-pass, fourth-order, V-180,
V-181
Chebyshev (*see* Chebyshev filters)
comb filter, digital, VI-218
combination filter, VI-212
CW filter, II-219, VI-29, VI-405
dynamic filter, III-190
four-output filter, V-182
full wave rectifier and averaging, I-
229, V-191
high-pass (*see* high-pass filters)
highpass amplifier, VI-49
IF filters
narrow-band, V-189
shortwave receiver, VI-212
I. filters, V-181
low-pass (*see* low-pass filters)
lowpass amplifier, VI-49
LP filter, active, VI-215
networks of, I-291
noise, dynamic, III-190
noisy signals, III-188
notch filters, I-283, II-397-403, III-
402-404
4.5 MHz, I-282
550 Hz, II-399
1800 Hz, II-398
active band reject, II-401
adjustable Q, II-398, V-179
audio, II-400
bandpass and, II-223
high-Q, III-404, V-178, VI-213,
VI-217, VI-220
RC, VI-221
selectable bandwidth, I-281
three-amplifier design, I-281
tunable, II-399, II-402, V-179
passive-bridged differentiator,
II-403
hum-suppressing, I-280
op amp, II-400
twin T notch for 1 kHz, V-183
twin-T, III-403
shortwave receivers, V-185
Wien bridge, II-402
passive I. filters, V-181
passive PI filters, V-181
passive T filters, V-190
Pi filters, V-181
PIN diode filter selection circuits,
VI-213
programmable, twin-T bridge, II-221
rejection, I-283
ripple suppressor, IV-175, IV-396
rumble, III-192, III-660, IV-175
LM387 in, I-297
turntable, IV-170
rumble/scratch, III-660
Sallen-Key filters
10 kHz, I-279
500 Hz bandpass, I-291
current-driven, V-189
high-pass, VI-209
low-pass, active, IV-177, VI-221
low-pass, equal component,
I-292
saw-filter impedance-matching
preamp, VI-222
scratch filters, III-189, III-660, IV-
175
LM287 in, I-297
second-order voltage-controlled,
VI-211
shortwave AM broadcast trap, VI-
214
shortwave interference trap, VI-214
stimulated inductor, V-180
speech filters
bandpass, 300 Hz 3 kHz, I-295
second-order, 300-to-3,400 Hz,
IV-174
two-section, 300-to-3,000 Hz,
IV-174
speech-range filter, bandpass, V-
185
state-variable filters, II-215, III-189,
VI-209, VI-216
multiple outputs, III-190
second-order, 1 kHz, Q/10, I-293
universal, I-290
T filters, V-190
tone filter, V-1 kHz, V-191
turbo, glitch free, III-186
twin-T bridge filter, II-221
Wien-bridge, III-659
variable Q filter, V-183
variable-frequency bandpass filter,
V-186
variable-state, universal, V-178
voltage-controlled filters, III-187,
IV-176, VI-211
VSB filter for LM 2880, VI-219
First-Response game, VI-247, VI-250,
VI-252, VI-253

fish lure, electronic, VI-386
 fixed power supplies, III-457-477, IV-390-408
 12-VDC battery-operated 120-VAC, III-464
 +24 V, 1.5 A supply from +12 V source, IV-401
 ± 35 V ac, IV-398
 ± 35 V, 5 A, mobile, IV-407
 15 V isolated to 2,500 V supply, IV-407
 ac motors, IV-395
 automotive battery supply, ± 15 V and 5 V, IV-391
 auxiliary supply, IV-394
 bias/reference applications, auxiliary negative dc supply, IV-404
 bilateral current source, III-469
 bridge rectifier, IV-398
 charge pool, III-469
 charge pump, regulated, IV-396
 constant-current source, safe, III-472
 converter, III-470
 5V-to-isolated 5V at 20mA, III-474
 ac-to-dc, IV-395
 dc-to-dc, 3-to-15 V, IV-400
 current sink, 1 mA, IV-402
 current sources, IV-399, IV-405, IV-406
 dc adapter/transceiver, hand-held, III-461
 dual-tracking regulator, III-462
 GASFET power supply, IV-405
 general-purpose, III-465
 inverter, 12 V input, IV-395
 isolated feedback, III-460
 LCD display power supply, IV-392, IV-403
 linear regulator, low-cost, low-dropout, III-459
 low-current source, IV-399
 low-power inverter, III-466
 negative rail, GBT, with CMOS gates, IV-408
 negative supply from +12 V source, IV-401
 negative voltage from positive supply, IV-397
 output stabilizer, IV-393
 portable-radio 3 V power supply, IV-397
 positive and negative voltage power supplies, IV-402
 pnp regulator, zener increases voltage output, II-484
 programmable, III-467
 rectifiers, III-471, IV-398
 regulated supplies, III-462, III-463, IV-401
 ripple suppressor, IV-396
 RTTY machine current supply, IV-400
 stabilizer, CMOS diode network, IV-406
 switching supplies, III-458, III-473, IV-403, IV-404, IV-408
 three-rail, III-466
 uninterruptible +5V, III-477
 voltage doubler, III-459, III-468
 voltage regulators (*see* voltage regulators)
 voltage-controlled current source/grounded source/load, III-468
 fixed-frequency generator, III-231
 flame ignitor, III-362
 flame monitor, III-313
 flash/flashbulb circuits (*see* photography-related circuits)
 flashers and blinkers (*see also* light-controlled circuits; photography-related circuits), I-304, II-225, III-193-210, IV-178-183, V-192-197, VI-223-227
 1.5 W, minimum power, I-308
 1 kW flip-flop, II-234
 1A lamp, I-306
 2 kW, photoelectric control in, II-232
 3V, I-306
 ac, III-196
 alternating, I-307, II-227
 astable multivibrator, III-196
 auto, I-299
 automatic safety, I-302
 automotive turn signal, sequential, I-109
 bar display with alarm, I-252
 barricade, I-299
 boat, I-299
 brake light flasher, V-69
 Christmas tree light flasher, V-197, V-264-265
 CMOS, III-199
 dc, adjustable on/off timer, I-305
 dual flasher for 555 circuits, VI-225
 dual LED CMOS, I-302
 electronic, II-228
 emergency lantern, I-308
 fast-action, I-306
 flash light, 60-W, III-200
 flicker light, IV-183
 flip-flop, I-299
 four-parallel LED, I-307
 headlight flasher, V-73
 high-efficiency parallel circuit, I-308
 high-voltage, safe, I-307
 high-power battery operated, II-229
 incandescent bulb, I-306, III-198
 lamp pulser, VI-227
 LED flashers, IV-181, V-195, V-196
 2- to 10-LED, V-196, VI-226, VI-227
 alternating, III-198, III-200
 Christmas tree lights, V-197, VI-225
 control circuit, IV-183
 dark-activated, V-195
 driver, V-194
 light-switched, VI-301
 multivibrator design, IV-182
 pulser, VI-226
 PUT used in, II-239
 ring-around, III-194
 sequential, reversible-direction, IV-182
 strobe, VI-224
 three-year, III-194
 UJT used in, II-231
 low-current consumption, II-231
 low-voltage, I-305, II-226
 miniature transistorized, II-227
 minimum-component, III-201
 model railroad crossing flasher, VI-395
 motorcycle brake light flasher, VI-12
 neon flashers, I-303, VI-225
 five-lamp, III-198
 two-state oscillator, III-200
 tube, I-304
 oscillator/flashers
 high-drive, II-235
 low-frequency, II-234
 photographic flashes
 slave-flash trigger, SCR design, IV-380, IV-382
 time-delay flash trigger, IV-380
 relay driver, low-frequency lamp, I-300
 running lights, V-269
 SCR flashers, II-230, III-197
 chaser, III-197
 relaxation, II-230
 ring counter, III-195
 sequencer, V-263, V-264-265
 sequential, II-233, II-238, IV-181, V-193
 pseudorandom simulated, IV-179
 signal alarm, V-197
 single-lamp, III-196
 strobe alarm, IV-180
 telephone, II-629, IV-556, IV-558, IV-559, IV-561
 transistorized, I-303, II-236, III-200
 variable, I-308
 xenon light, IV-180
 flashlight, rechargeable LED light, VI-107
 flashlight finder, I-300
 flex switch, alarm sounder circuit, V-15
 flip-flops (*see* bistable multivibrators)
 flood alarm, I-390, III-206, IV-188
 flow-detectors, II-240-242, III-202-203
 air, II-242
 liquids, II-248, III-202-203
 low-rate thermal, III-203
 thermally based anemometer, II-241
 fluid and moisture detectors, I-388, I-390, I-442, II-243-248, III-204-210, IV-184-191, V-373-375
 acid rain monitor, II-245, V-371
 alarm, water-activated, V-374
 checker, III-209
 control, I-388, III-206
 cryogenic fluid-level sensor, I-386
 dual, III-207
 flood alarm, III-206, IV-188, V-374
 flow-of liquid, II-248, III-202-203
 full-bathtub indicator, IV-187
 full-cup detector for the blind, IV-189
 humidity, II-285-287, III-266-267, VI-255-257
 hydrophone, VI-378
 indicator, II-244
 level of liquid, I-107, I-235, I-387, I-388, I-389, I-390, II-174, II-244, II-246, III-205, III-206, III-207, III-209, III-210, IV-186, IV-190, IV-191
 moisture detector, I-442, IV-188, V-375
 monitor, III-210
 plant water, II-245, II-248, III-208
 pump controller, single-chip, II-247
 rain alarm, II-244, IV-189
 sensor and control, II-246
 soil moisture, II-245, II-248, III-208
 temperature monitor, II-643, III-206
 water-leak alarm, IV-190
 windshield-washer level, I-107

fluorescent lamps
 high-voltage power supplies, cold-cathode design, IV-411
 inverter, 8-W, III-306
 vacuum, fluorescent display, II-185
 flyback converters, I-211
 self oscillating, I-170, II-128, III-748
 voltage, high-efficiency, III-744
 flyback power supply, VI-531
 flyback regulator, off-line, II-481
 FM-related circuits (*see also* radio/rf circuits)
 5 V, I-233
 12 V, I-233
 antenna booster, tunable, VI-65
 antenna for automobile radio, VI-64-65
 bug, VI-662
 clock radio, AM/FM, I-543
 decoder, VI-170
 demodulators, I-544, II-159, II-161, V-151
 FM-modulated oscillator, VI-449
 FM/AM receiver, VI-541
 high frequency oscillator, VI-456
 IF amplifier with quadrature detector, TV sound IF, I-690
 infrared FM audio reception, VI-268
 generators, low-frequency, III-228
 modulators, V-366
 555-based circuit, V-367
 NB FM audio amplifier, VI-74
 radio, I-545
 receivers
 27.145 MHz, V-495
 carrier-current circuit, III-80
 light-beam, V-259
 MPX/SCA receiver, III-530
 narrow-band, III-532
 optical receiver/transmitter, 50 kHz, I-361
 zero center indicator, I-338
 SCA subcarrier adapter, V-536
 scanner noise squelch, VI-579
 snooper, III-680
 speakers, remote, carrier-current system, I-140
 squelch circuit for AM, I-547
 stereo demodulation system, I-544
 transmitters, I-681, V-641
 27.125-MHz NBFM, V-637
 49-MHz, V-643
 infrared, voice-modulated pulse, IV-228
 light-beam, V-259
 multiplex, III-688
 one-transistor, III-687
 optical, I-367, II-417
 optical receiver/transmitter, 50 kHz, I-361
 radio, V-648
 snooper, III-680
 stereo, V-575, V-580, VI-662
 voice, III-678
 tuner, I-231, III-529
 wireless microphone, III-682, III-685, III-691
 FM/AM clock radio, I-543
 fog-light controller, automotive, IV-59
 foldback current, HV regulator limiting, II-478
 followers, III-211-212
 inverting, high-frequency, III-212
 noninverting, high-frequency, III-212
 source, photodiode, III-419
 unity gain, I-27
 voltage, III-212
 forward-current booster, III-17
 free-running multivibrators, II-485
 100 kHz, I-465
 programmable-frequency, III-235
 free-running oscillators, I-531
 square wave, I-615
 freezer, voltage, III-763
 freezer-meltdown alarm, I-13
 frequency comparators, II-109, III-88
 LED, II-110
 VCO and input, VI-353
 frequency control, telephone, II-623
 frequency converter, I-159
 frequency counters, III-340, III-768, IV-300, V-129-133, VI-360
 1.2 GHz, III-129
 2 MHz, V-130-131
 10-MHz, III-126, V-132-133
 100 MHz, period and, II-136
 low-cost, III-124
 preamp, III-128, V-24
 precision, I-253
 tachometer and, I-310
 frequency detectors, II-177, III-158, VI-180
 beat indicator, I-336
 boundary detector, III-156
 comparator, III-88
 digital, III-158
 limit, frequency limit, II-177
 window, frequency window, III-777
 frequency dividers, I-258, II-251, II-254, III-213-218, III-340, III-768, V-343
 1.2 GHz, III-129
 10-MHz, III-126
 10-MHz frequency standard, VI-341
 clock input, IV-151
 decade, I-259
 divide-by-1.5, III-216
 low-cost, III-124
 low-frequency, II-253
 preamp, III-128
 programmable, IV-152-153
 staircase generator and, I-730
 tachometer and, I-310
 frequency-division multiplex stereo decoder, II-169
 frequency doublers, I-313, III-215, VI-369
 broadband, I-313
 digital, III-216
 GASFET design, IV-324
 low-frequency, I-314
 single-chip, III-218
 to 1 MHz, II-252
 frequency generators, fixed-frequency, III-231
 frequency indicator, beat, I-336
 frequency inverter, III-297
 frequency meters, I-310, II-249-250, IV-282, IV-301, VI-335
 analog, V-307
 audio-frequency meter, V-305, V-320
 audio, I-311
 linear, I-310
 low-cost, II-250
 power, II-250
 frequency multipliers, II-251, III-213-218, V-198-199, VI-388
 counter, odd-number, III-217
 doublers, I-313, III-215
 broadband, I-313
 digital, III-216
 GASFET design, IV-324
 single-chip, III-218
 low-frequency, I-314
 pulse-width, III-214
 tripler, nonselective, II-252
 frequency-boundary detector, III-156
 frequency oscillator, tunable, II-425
 frequency probe, VI-524
 frequency-ratio monitoring circuit, IV-202
 frequency shift key (FSK)
 communications
 data receiver, III-533
 decoder, 10.8 MHz, I-214
 generator, low-cost design, III-227
 keying circuits, IV-245
 frequency standard, VI-10-MHz, VI-361
 frequency synthesizer, programmable voltage controlled, II-265
 frequency-to-voltage converter, I-318, II-255-257, III-219-220, VI-231-233
 dc, 10 kHz, I-316
 digital meter, I-317
 optocoupler input, IV-193
 sample-and-hold circuit, IV-194
 single-supply design, IV-195
 zener regulated, I-317
 fuel gauge, automotive, IV-46
 full-wave rectifiers, IV-328, IV-650
 absolute value, II-328
 averaging filter, V-191
 op amp circuit, V-403
 precision, I-234, III-537
 silicon-controlled (SCR), I-375
 function generators (*see also* burst generators; sound generators; waveform generators), I-729, II-271, III-221-242, III-258-274, IV-198-202, V-200-207, V-309, VI-234-243
 555 astable, low-duty cycle, II-267
 acoustic field generator, V-338-341, V-338
 AM broadcast-band signal generator, IV-302
 AM/IF signal generator, 455 kHz, IV-301
 astable multivibrators, II-269, II-510, II-597, III-196, III-224, III-233, III-237, III-238
 audio function generator, IV-197
 audio-frequency generator, V-416-417, V-416
 bistable multivibrators, I-133, I-299, I-395, II-367, II-465, III-103, IV-108, IV-651
 bistable multivibrators, I-133, II-465
 capacitance multiplier, V-205
 clock generator/oscillator, I-193, I-615
 complementary signals, XOR gate, III-226
 DAC controlled, I-722
 debouncer, IV-108
 emitter-coupled RC oscillator, II-266
 fixed-frequency, III-231
 flasher, I-299, II-234
 FM, low-frequency, III-228
 free-running multivibrator, programmable-frequency, III-235
 frequency-ratio monitoring circuit, IV-202

- function generators, *continued*
 - frequency synthesizer,
 - programmable voltage controlled, II-265
 - FSK, low-cost, III-227
 - harmonic generators, I-24, III-228, IV-649
 - high-frequency, II-150
 - inverter, III-103
 - lamp driver, IV-160
 - line/bar generator, video, V-662
 - linear ramp, II-270
 - linear triangle/square wave VCO, II-263
 - logarithmic
 - dynamic-range, V-201
 - fast acting, V-202
 - monostable multivibrators, I-465, III-229, III-230, III-235, III-237
 - input lockout, I-464
 - linear-ramp, III-237
 - photocell, monostable, II-329
 - positive-triggered, III-229
 - TTL, monostable operation, I-464
 - UJT, monostable operation, I-463
 - video amplifier and comparator, II-268
 - multiplying pulse width circuit, II-264
 - multivibrators
 - low-frequency, III-237
 - single-supply, III-232
 - nonlinear potentiometer outputs, IV-198
 - one-shots, I-465, VI-419
 - digitally controlled, I-720
 - precision, III-222
 - retriggerable, III-238
 - oscillator/amplifier, wide frequency range, II-262
 - pattern generator/polar-to-rect. converter, V-288
 - polynomial generator, V-287
 - potentiometer-position V/F converter, IV-200
 - precise wave, II-274
 - programmed, I-724
 - pseudo-random bit sequence generator, V-351
 - pulse generators, II-508-511
 - 2-ohm, III-231
 - 300-V, III-521
 - 555-circuit, IV-439
 - astable multivibrator, II-510
 - clock, 60 Hz, II-102
 - CMOS short-pulse, III-523
 - delayed-pulse, II-509, IV-440
 - divider, programmable, II-511, III-226
 - EEPROM, 5V-powered, III-99
 - free running, IV-438
 - interrupting pulse-generation, I-357
 - logic, III-520
 - logic troubleshooting
 - applications, IV-436
 - programmable, I-529
 - sawtooth-wave generator and, III-241
 - single, II-175
 - train, pulse train, IV-202
 - transistorized, IV-437
 - two-phase pulse, I-532
 - unijunction transistor design, I-530
 - very low-duty-cycle, III-521
 - voltage-controller and, III-524
 - wide-ranging, III-522
 - quad op amp, four simultaneous synchronized waveform, II-259
 - ramp generators, I-540, II-521-523, III-525-527, IV-443-447
 - 555 based, V-203
 - accurate, III-525
 - integrator, initial condition reset, III-527
 - linear, II-270
 - variable reset level, II-267
 - voltage-controlled, II-523
 - rf oscillator, V-530-531
 - root extractor, V-207, V-288
 - RS flip-flop, I-395
 - sawtooth generators, V-491
 - linear, V-205
 - triggered, V-204
 - sawtooth and pulse, III-241
 - Schmitt trigger, transistorized, V-204
 - SCR, II-367
 - self-retriggering timed-on generator, V-343
 - signal generators, V-204
 - AM broadcast band, IV-302
 - AM/FM, 455 kHz, IV-301
 - high-frequency, II-150
 - square-wave, III-583-585
 - staircase, III-586-588
 - two-function, III-234
 - sine-wave generators, IV-505, IV-506, V-542, V-543, V-544
 - 60 Hz, IV-507
 - audio, II-564
 - battery power, V-541
 - LC, IV-507
 - LF, IV-512
 - oscillator, audio, III-559
 - square-wave and, tunable oscillator, III-232
 - VLF audio tone, IV-508
 - sine/cosine (0.1-10 kHz), II-260
 - sine/square wave oscillators, I-65
 - TTL design, IV-512
 - tunable, I-65, III-232
 - single control, III-238
 - single supply, II-273
 - square-wave generators, II-594-600, III-225, III-239, III-242, III-583-585, IV-529-536, V-568-570
 - 1 kHz, IV-536
 - 2 MHz using two TTL gates, II-598
 - 555 timer, II-595
 - astable circuit, IV-534
 - astable multivibrator, II-597
 - CMOS 555 astable, true rail-to-rail, II-596
 - duty-cycle multivibrator, III-50-percent, III-584
 - four-decade design, IV-535
 - high-current oscillator, III-585
 - line frequency, II-599
 - low-frequency TTL oscillator, II-595
 - multiburst generator, II-88
 - multivibrator, IV-536
 - oscillators, I-612-614, I-616, II-596, II-597, II-616, IV-532, IV-533
 - phase-tracking, three-phase, II-598
 - pulse extractor, III-584
 - quadrature-outputs oscillator, III-585
 - sine-wave and, tunable oscillator, III-232
 - three-phase, II-600
 - tone-burst generator, single timer IC, II-89
 - triangle-wave and, III-239
 - precision, III-242
 - programmable, III-225
 - wide-range, III-242
 - TTL, LSTTL, CMOS designs, IV-530-532
 - variable duty-cycle, IV-533
 - variable-frequency, IV-535
 - SR flip-flop, IV-651
 - stable function generator, VI-242
 - staircase generators, I-730, II-601-602, III-586-588, IV-443-447
 - sweep generators, I-472, III-438, VI-238-241
 - timebase
 - 1 Hz, readout and counter applications, IV-201
 - oscilloscopes, V-425
 - time-delay generator, I-217-218
 - tone burst generator, repeater, V-629
 - triangle-wave, III-234, V-203, V-205
 - clock-driven, V-206
 - square wave, III-225, III-239, III-242
 - timer, linear, III-222
 - triangle/square wave generator, V-206
 - tunable, wide-range, III-241
 - two-function, III-234
 - UJT monostable circuit insensitive to changing bias voltage, II-268
 - variable duty cycle timer output, III-240
 - voltage controlled high-speed one shot, II-286
 - waveform (*see* waveform generators)
 - white noise generator, IV-201
 - wide-range function generator, VI-243
 - funk box, II-593
 - furnace exhaust gas/smoke detector, temp monitor/low-supply detection, III-248
 - furnace fuel riser, V-328-329
 - fuses
 - battery-charger relay fuse, V-88
 - electronic, V-477
 - monitor for car fuses, V-77
 - relay fuse, V-478
 - fuzz box, III-575
 - fuzz sound effect, II-590
- ## G
- GaAsFET circuits
 - amplifier, power, with single supply, II-10
 - fixed power supplies, IV-405
 - gain control circuits
 - amplifier, stereo, gain-controlled, II-9, III-34
 - automatic audio gain control, II-17
 - automatic gain control (AGC), II-17
 - AGC system for CA3028 IF amp, IV-458
 - rf amplifier, wideband adjustable, III-545
 - squelch control, III-33
 - wide-band amplifier, III-15
 - gain block, video, III-712
 - galvanometer, sine/cosine generator, VI-700

- game feeder controller, II-360
game roller, I-326
games, II-275-277, III-243-245, IV-203-207, V-208-211, VI-244-254
coin flipper, III-244
coin toss game, VI-250
craps game, VI-245
electronic dice, III-245, IV-207
electronic roulette, II-276, IV-205
First-Response Monitor, VI-247, VI-250, VI-252, VI-253
fish lure, electronic, VI-386
Jacob's Ladder, VI-389
lie detector, II-277, IV-206
model car derby winner indicator, VI-259
one-arm bandit game, VI-251
quiz master, V-210
reaction timer, IV-204
ring launcher, electromagnetic, V-209
roulette, II-276, IV-205
run-down clock/sound generator, IV-205
slot machine, V-211
Twenty-One game, VI-246
Wheel-of-Fortune, IV-206, VI-254
who's first, III-244
Z-Dice game, VI-248-249
garage stop light, II-53
gas detectors (*see also* smoke alarms and detectors), I-332, II-278-279, III-246-253, V-212-214
analyzer and, II-281
combustible gas detector, V-214
explosive gas detector, V-213
furnace exhaust, temp monitor/low-supply detection, III-248
methane concentration, linearized output, III-250
toxic, II-280
SCR, III-251
smoke/gas/vapor detector, III-250
gate dip oscillator, VI-344, VI-346
gated oscillator, last-cycle completing, III-427
gated-pulse descrambler, II-165
gates, V-215-216
AND, I-395, V-216
OR, I-395
programmable, I-394
sync gating circuit, V-595
XOR gate, IV-107
Geiger counters, I-536-537, V-217-219, VI-531
high-voltage supply, II-489
pocket-sized, II-514
gel cell charger, II-66
generators, electric-power
corona-wind generator, IV-633
dc generator, V-443
high-voltage generators, IV-413
ion generator, V-248-249
battery-powered, III-482
capacitor-discharge, III-485
dc voltage, III-481
negative-ions, IV-634
regulator for automobile generator, V-76
ultra-high-voltages, II-488
generators (*see* function generators; sound generators; waveform generators)
glitch-detector, comparator, II-107
glow-plug driver, II-52
gong, electronic, V-563
graphic equalizer, ten-band, active filter in, II-684
grid-dip meters, I-247, II-182-183
bandswitched, IV-298
basic grid, I-247, IV-298
dual gate IGFET, I-246
little dipper, II-183
varicap tuned FET, I-246
grid-leak detector, VI-179
grounding
ground loop preventer, VI-390
tester, II-345
ground-fault Hall detector, IV-208-209
ground-noise probe, battery-powered, III-500
pseudoground, VI-431
guitars
compressor, sound-effect circuit, IV-519
matching audio signal amplifiers, IV-38
mixer, low-noise, four-channel, V-360-361
treble boost for, II-683
tuner, II-362
gun, laser, visible red and continuous, III-310
- H**
half-duplex information transmission link, III-679
half-flash analog-to-digital converters, III-26
half-wave ac phase controlled circuit, I-377
half-wave rectifiers, I-230, III-528, IV-325
fast, I-228
Hall-effect circuits, II-282-284, III-254-258, V-220-222
angle of rotation detector, II-283
compass, III-258
compass, talking, V-221
current monitor, III-255, IV-284
door open alarm, II-284
ground-fault detector, IV-208-209
oscillators, V-222
security door-ajar alarm, III-256
switches using, III-257, IV-539
halogen lamps
dimmer for, III-300
protector, V-271
handtalkies, I-19
two-meter preamplifier for, I-19
hands-free telephone, III-605
hands-off intercom, III-291
handset encoder, telephone, III-613
harmonic distortion
analyzer, V-291, VI-357
meter, V-312
harmonic generators, I-24, III-228, IV-649
Hartley oscillator, I-571, V-140, VI-453, VI-459
HC-based oscillators, III-423
HCU/HTC-based oscillator, III-426
headlights (*see* automotive circuits, headlights)
headphones
amplifier for, II-43
car protector circuit, V-482
infrared (IR) receiver, V-227, VI-269
infrared (IR) transmitter, V-227, VI-263
signal amplifier, V-53, V-57
heart rate monitor, II-348, II-349, V-342
heat-activated alarm, V-9
heat sniffer, electronic, III-627
heaters/heater controls (*see also* temperature-related circuits), I-639
element controller, II-642
induction heater, ultrasonic, 120-kHz 500-W, III-704
protector circuit, servo-sensed, III-624
temperature sensitive, I-640
hee-haw siren, II-578, III-565
hexFET switch, V-592
dual-control, V-593
hi-fi circuits (*see* stereo circuits)
high-pass filters, I-296, VI-210, VI-221
active, I-296, V-180, V-188, VI-213
fourth-order, V-188
second-order, I-297
amplifier, VI-49
Butterworth, fourth-order, I-280, V-179
Chebyshev, fourth-order, III-191
equal components second-order, V-188
fourth-order, 100-Hz, IV-174
Sallen Key, VI-209
second-order, 100-Hz, IV-175
sixth-order elliptical, III-191
unity-gain second-order, V-187
variable, V-186
wideband two-pole, II-215
high-voltage power supplies (*see also* generators, electrical power; power supplies), II-487-490, III-486, IV-409-413, V-442-447, VI-499-505
9- to 15-Vdc input, V-456
-100-Vdc supply, VI-502
12-V supply for fluorescent lamp, VI-500
10,000 V dc supply, IV-633
ac operated He-Ne laser power supply, VI-502
arc-jet power supply, starting circuit, III-479
basic circuit, V-446
battery-powered generator, III-482
bucking regulator, III-481
control circuit, VI-501
dc generator, III-481, V-443
dc supply, 120-240 Vdc, single-chip circuit, V-446
fluorescent-lamp supply, V-444
cold-cathode design, IV-411, V-447
Geiger counter supply, II-489
generators (*see* generators, electrical power)
inverter, III-484
40 W, 120 V ac, IV-410-411
Kirlian device supply, VI-504
laser circuits, V-253
negative supply, V-445
negative-ion generator, IV-634
night-vision scope power supply, VI-501
optoisolated driver, III-482
photomultiplier supply, V-444, V-445
preregulated, III-480
pulse supply, IV-412
pulse-width modulated laser supply, VI-505

- high-voltage power supplies
 - continued*
 - regulators, III-485
 - foldback-current limiting, II-478
 - solid-state, remote adjustable, III-486
 - strobe power supply, IV-413
 - tripler, VI-504
 - tube amplifier, high-volt isolation, IV-426
 - ultra high-voltage generator, II-488
 - voltage regulators, VI-500, VI-503, VI-505
 - hobby circuits (*see* model and hobby circuits)
 - hold button, telephone, I-612, II-628
 - home security systems (*see* alarms; annunciators)
 - horizontal deflection circuit, VI-382
 - horn, automobile, III-50, IV-54
 - hour/time delay sampling circuit, II-668
 - Howland current pump, II-648
 - hum reducer circuit, receivers, V-347
 - humidity sensor, II-285-287, III-266-267, VI-255-257
 - hybrid power amplifier, III-455
 - hydrophone, VI-378
- I**
- IC product detectors, IV-143
 - IC timer, crystal-stabilized, subharmonic frequencies for, II-151
 - ice formation alarm, I-106, II-57, II-58
 - ICOM IC-2A battery charger, II-65
 - IF amplifiers, I-690, IV-459
 - AGC system, IV-458
 - preamp, IV-460
 - receiver, IV-459
 - quadrature detector, TV sound IF, I-690
 - two-stage, 60 MHz, I-563
 - video IF amplifier/detector, VI-678
 - wideband, I-689
 - ignition circuits, automotive, V-64
 - capacitor discharger, I-103
 - cut-off circuit, automotive, IV-53
 - electronic, IV-65
 - substitute ignition, III-41
 - timing light for ignition system, II-60
 - ignitor, III-362
 - illumination stabilizer, machine vision, II-306
 - image canceller, III-358
 - immobilizer, II-50
 - impedance checker, V-136
 - impedance converter, high-to low, I-41
 - impedance sensor, nanoampere, 100 megohm input, I-203
 - indicators (*see* measurement/test circuits)
 - in-use indicator, telephone, II-629
 - inductance meter/tester, V-316, VI-330, VI-358
 - induction heater, ultrasonic, 120-kHz 500-W, III-704
 - inductors
 - active, I-417
 - simulated, II-199, V-180
 - infrared circuits (*see also* light-control devices); remote control devices), II-288-292, III-271-277, IV-219-228, V-223-229, VI-261-271
 - body-heat detector, VI-266
 - data link, I-341
 - detector, II-289, III-276, IV-224, V-225, VI-262, VI-266
 - emitter drive, pulsed, II-292
 - fan controller, IV-226
 - filter circuit, narrow-band, V-189
 - headphone receiver, V-227
 - headphone transmitter, V-227
 - ion detector, VI-267
 - IR pulse-to audio converter, V-224
 - laser light detector, VI-293
 - laser rifle, invisible pulsed, II-291
 - long-range object detector, III-273
 - loudspeaker link, remote, I-343
 - low-noise detector for, II-289
 - night-vision illuminator, VI-265
 - object detector, long-range, III-273
 - people-detector, IV-225
 - preamplifier for IR photodiode, V-226
 - proximity switch, infrared-activated, IV-345
 - receivers, I-342, II-292, III-274, IV-220-221, V-226, V-229, VI-268
 - audible-output, VI-271
 - data-link, low power, VI-265
 - FM audio reception, VI-268
 - light, VI-294
 - pulse frequency modulated, VI-269
 - single-tone, VI-264, VI-270
 - steady-tone, VI-267
 - wireless headphones, VI-269
 - remote A/B switch, V-225
 - remote controller, I-342, IV-224, V-229
 - remote-control analyzer, V-224
 - remote-control tester, IV-228, V-228, V-229
 - remote-extender, IV-227
 - transmitters, I-343, II-289, II-290, III-274, III-276, III-277, IV-226-227
 - audio-modulated, VI-262
 - digital, III-275
 - pulsed for on/off control, V-228
 - remote-control, I-342
 - voice-modulated pulse FM, IV-228
 - wireless headphones, VI-263
 - TV remote control relay, VI-263
 - wireless speaker system, III-272, IV-222-223
 - injectors
 - three-in-one set: logic probe, signal tracer, injector, IV-429
 - injector-tracers, I-521, I-522, II-500
 - input selectors, audio, low-distortion, II-38
 - input/output buffer, analog multiplexers, III-11
 - input/output circuits, NE602-based, V-355
 - instrumentation amplifiers, I-346, I-348, I-349, I-352, II-293-295, III-278-284, IV-229-234, V-233-235, VI-272-277
 - ± 100 V common mode range, III-294
 - ac-coupled, VI-276
 - current collector head amplifier, II-295
 - differential, I-347, I-354, III-283
 - biomedical, III-282
 - high-gain, I-353
 - input, I-354, VI-275
 - variable gain, I-349
 - extended common-mode design, IV-234
 - high input-impedance, VI-275
 - high-impedance low-drift, I-355
 - high-speed, I-354
 - LM6218-based, high-speed, V-235
 - LMC6062-based, V-234
 - low-drift/low-noise dc amplifier, IV-232
 - low-signal level/high-impedance, I-350
 - low-noise, VI-276
 - low-power, III-284, VI-276
 - meter driver, II-296
 - preamps
 - oscilloscope, IV-230-231
 - thermocouple, III-283
 - precision FET input, I-355
 - programmable gain, VI-275
 - saturated standard cell amplifier, II-296
 - strain gauge, III-280
 - triple op amp, I-347
 - ultra low-noise, VI-277
 - ultra-precision, III-279
 - variable gain, differential input, I-349, VI-274
 - very high-impedance, I-354
 - wideband, III-281
 - instrumentation meter driver, II-296
 - integrators, II-297-300, III-285-286, V-236-237, VI-278-279
 - ac integrator, VI-279
 - active, inverting buffer, II-299
 - bias-current compensated, VI-279
 - JFET ac coupled, II-200
 - gamma ray pulse, I-536
 - long time, II-300
 - low-drift, I-423
 - noninverting, improved, II-298
 - photocurrent, II-326
 - programmable reset level, III-286
 - ramp generator, initial condition reset, III-527
 - resettable, III-286
 - intercoms, I-115, II-301-303, III-287-292, V-238-240, VI-376
 - bidirectional, III-290
 - carrier current, I-146
 - hands-off, III-291
 - party-line, II-303
 - pocket pager, III-288
 - telephone-intercoms, IV-557, V-239, V-240
 - two-way, III-292
 - two-wire design, IV-235-237
 - voice-activated, one-way, V-239
 - intercoms (*see also* telephone-related circuits), V-238
 - interfaces (*see also* computer circuits), IV-238-242, V-241-244, VI-280-281
 - 680x, 650x, 8080 families, III-98
 - amateur radio transceiver, relay interface, V-243
 - audio/telephone interface, VI-625
 - audio-to-ADC interface, V-242
 - cassette-to-telephone, III-618
 - CPU interface, one-shot design, IV-239
 - DVM, temperature sensor and, II-647
 - FET driver, low-level power FET, IV-241
 - fiberoptic, II-207
 - keyboard matrix interface, IV-240
 - logic-level translators, IV-242

- microcomputer-to-triac interface, V-244
 - optical-sensor-to-TTL, III-314
 - optocouplers, V-406-407
 - optoisolators, V-406-407
 - preamp receiver interface, V-243
 - process control, I-30, V-242
 - RC receiver relay interface, VI-551
 - remote-control transmitter interface, V-511
 - resistive transducer interface, VI-281
 - RS-232, computer-powered, VI-138-139
 - RS-422 to RS-232 converter, VI-133
 - tape recorder, II-614
 - telephone
 - audio interface, V-612
 - telephone-line interface, V-605
 - timer/ac line interface, VI-281
 - transmit keyer interface circuit, VI-31
 - video interface with sync stripper, V-659
 - interrupter, ground fault, I-580
 - interval timer, low-power, microprocessor programmable, II-678
 - intruder-detector, light-beam
 - activated, V 11
 - preamp, V-13
 - inverters, III-293-298, V-245-247, VI-282-285
 - 250 watt, V-246
 - analog switched inverter, VI-604
 - dc-to-ac, V-247
 - dc-to-dc/ac, I-208
 - digital, V-246
 - fast, I-422
 - fixed power supplies, 12 V input, IV-395
 - flip-flop, III-103
 - fluorescent lamp, 8-W, III-306
 - frequency inverter, III-297
 - high-voltage, III-484
 - 40 W, 120 V ac, IV-410-411
 - low-power, fixed power supplies, III-466
 - on/off switch, III-594
 - picture, video circuits, III-722
 - positive-to-negative dc/dc inverter, VI-285
 - power, III-298
 - 12 VDC-to-117 VAC at 60 Hz, III-294
 - medium, III-296
 - MOSFET, III-295, V-247
 - rectifier/inverter, programmable op-amp design, IV-364
 - signal source for audio
 - amplifier/inverter, VI-702
 - ultrasonic, arc welding, 20 kHz, III-700
 - variable frequency, complementary output, III-297
 - voltage, precision, III-298
 - inverting amplifiers, I-41-42, III-14
 - ac, high-gain, I-92
 - balancing circuit in, I-33
 - gain of 2, lag-lead compensation, UHF, I-566
 - low-power, digitally selectable gain, II-333
 - power amplifier, I-79
 - programmable-gain, III-505
 - SCR inverter and trigger, VI-283
 - sine-wave inverter, VI-285
 - unity gain amplifier, I-80
 - vehicle audio amplifier inverter, VI-284
 - wideband unity gain, I-35
 - ion detector, VI-267, VI-533
 - ion generator, V-248-249, VI-286-288
 - isolated feedback power supply, III-460
 - isolation amplifiers
 - capacitive load, I-34
 - level shifter, I-348
 - medical telemetry, I-352
 - rf, II-547
 - isolation and zero voltage switching logic, II-415
 - isolation transformer, V-349, V-470
 - isolators
 - analog data-signal transmission, IV-133
 - digital transmission, II-414
 - stimulus, III-351
- J**
- Jacob's Ladder, VI-389
 - JFET circuits
 - ac coupled integrator, III-200
 - amplifiers
 - 500-Mohm input impedance, V-23
 - current source biasing, V-21
 - chopper circuit, V-352
 - headphone audio signal amplifiers, V-57
 - oscillator, variable frequency, VI-449
 - preamplifier, V-22
 - source follower, V-20
 - voltmeter, V-318
 - jitter suppression, V-342
- K**
- kaleidoscope, sonic, V-548-549
 - Kelvin thermometer, I-655
 - zero adjust, III-661
 - key illuminator, V-333
 - keyer, electronic CW "bug" keyer, V-102
 - keying circuits, IV-243-245
 - AFSK generator, one-chip, VI-23
 - automatic operation, II-15
 - automatic TTL Morse code, I-25
 - CW keyer, IV-244
 - CW transmitter, VI-22-23
 - electronic, I-20
 - frequency-shift keyer, IV-245
 - negative key line keyer, IV-244
 - PTT control from receiver audio, VI-28
 - transmit keyer interface circuits, VI-31
 - wireless RTS keyer with data, VI-136
 - Kirlian device supply, VI-504
- L**
- lamp-control circuits (*see* lights/light-activated and controlled circuits)
 - laser circuits (*see also* lights/light-activated and controlled circuits; optical circuits), II-313-317, III-309-311, V-250-254, VI-289-296
 - ac operated He-Ne laser power supply, VI-502
 - dc supply, VI-295
 - diode sensor, IV-321
 - discharge current stabilizer, II-316
 - drivers
 - IC-based, VI-296
 - op-amp, VI-295
 - pulsed double-heterostructure laser, VI-296
 - single heterostructure diode, VI-290
 - gun, visible red, III-310
 - handheld laser, V-252
 - high-voltage supply for He-Ne laser, VI-291
 - IR laser light detector, VI-293
 - light detector, II-314
 - power supply, IV-636, V-251, V-254
 - high-voltage, V-253
 - with starter circuit, V-252
 - pulse-width modulated laser supply, VI-505
 - pulsers, laser diode, I-416, III-311
 - receiver, IV-308
 - PLL IR, VI-294
 - sound effect generator for laser pistol, VI-292
 - rifle, invisible IR pulsed, II-291
 - simulated laser using LED, V-253
 - transmitter, VI-292
 - latches, V-356
 - 12-V, solenoid driver, III-572
 - comparator and, III-88
 - latching relays, dc, optically coupled, III-417
 - latching switches
 - double touchbutton, I-138
 - SCR-replacing, III-593
 - LCD display
 - 7-segment, V-165
 - contrast temperature compensator, VI-195
 - fixed-power supply, IV-392, IV-403
 - large-size, V-164
 - lead-acid batteries (*see also* battery-related circuits)
 - battery chargers, III-55
 - life-extender and charger, IV-72
 - low-battery detector, III-56
 - leading-edge delay circuit, III-147
 - LED circuits
 - 7-segment, V-166
 - ac-power indicator, IV-214
 - alternating flasher, III-198, III-200
 - back-biased GaAs LED light sensor, II-321
 - bar graph driver, II-188, VI-195
 - battery-charger test circuit, V-89
 - blinker, light-controlled, VI-301
 - brightness, I-250
 - Christmas tree light flasher, V-197, VI-225
 - color shifting LED display, VI-189
 - common-cathode display, V-167
 - driver, emitter/follower, IV-159
 - flashers, V-195, V-196, VI-226, VI-227
 - alternating, III-198, III-200
 - Christmas tree lights, V-197
 - control circuit, IV-183
 - dark-activated, V-195
 - driver, V-194
 - multivibrator design, IV-182
 - PUT used in, II-239
 - ring-around, III-194
 - sequential, reversible-direction, IV-182
 - three-year, III-194
 - UJT used in, II-231
 - frequency comparator, II-110

- LED circuits *continued*
- light sensor, back-biased GaAsFET, II-321
 - leading-zero suppressed display, V-165
 - matrix display, two-variable, III-171
 - millivoltmeter readout, IV-294
 - multiplexed common-cathode display ADC, III-764
 - output indicator for 555 circuits, VI-260
 - panel meter, III-347
 - peakmeter, III-333
 - pulsar, VI-226
 - receivers for lightwave communications, VI-310
 - ring-around flasher, III-194
 - RS-232C, computer circuit, III-103
 - simulated-laser circuit, V-253
 - strobe, random, VI-224
 - three-year flasher, III-194
 - transmitter for lightwave communications, VI-309
 - voltmeter, IV-286
 - VU meter, IV-211
 - level, electronic, II-666, IV-329, VI-328
 - level controllers/detectors (*see also* fluid and moisture), II-174
 - alarm, water, I-389
 - audio, automatic, II-20
 - audio (ALC), V-60-62
 - cryogenic fluid, I-386
 - hysteresis in, I-235
 - level of liquid, I-107, I-235, I-387, I-388, I-389, I-390, II-174, II-244, II-246, III-205, III-206, III-207, I-209, III-210, IV-186, IV-190, IV-191
 - meter, LED bar/dot, I-251
 - peak, I-402
 - sound, I-403
 - three-step, I-336
 - visual, III-269
 - warning
 - audio output, low, I-391
 - high-level, I-387
 - level shifter, negative-to-positive supply, I-394
 - LF or HF field strength meter, II-212
 - LF receiver, IV-451
 - lic detector, II-277, IV-206, V-255-256
 - light-beam communication circuits, V-257-261
 - receivers
 - audio, visible-light, V-261
 - FM light-beam, V-259
 - modulated light, V-258
 - voice-communication, V-260
 - transmitters
 - audio, visible-light, V-261
 - FM light-beam, V-259
 - modulated light, V-258
 - voice-communication, V-260
 - light-controlled circuits (*see also* laser circuits; optical circuits), II-304-312, II-318-331, III-312-319, V-262-283, VI-297-312
 - 860 W limited-range light control, I-376
 - alarms, V-9, V-273
 - dark-activated alarm, pulsed tone, V-13
 - high-output, pulse-tone, V-14
 - precision design, V-12
 - self-latch, tone output, V-15
 - with hysteresis, V-14
 - with latch, V-12
 - light-beam intruder-detection, V-11, V-13
 - ambient-light cancellation circuit, II-328
 - ambient-light ignoring optical sensor, III-413
 - audio oscillator, light-sensitive, III-315
 - back-biased GaAs LED sensor, II-321
 - black light, battery-operated, V-281
 - battery-powered light, capacitance operated, I-131
 - brightness control, I-377, III-316
 - carport light, automatic, II-308
 - chaser lights, sequential activation, IV-251, IV-252
 - Christmas light driver, IV-254
 - Christmas tree lights sequencer, V-264-265
 - colorimeter, VI-306-307
 - complementary, I-372
 - controller, IV-252
 - cross fader, II-312
 - darkness monitor, VI-303
 - detectors of light, I-362, IV-369
 - dimmers, I-369, II-309, IV-247, IV-249, V-266, VI-377
 - 800 W, II-309
 - CMOS touch dimmer, V-270
 - dc lamp, II-307
 - four-quadrant, IV-248-249
 - halogen lamps, III-300
 - headlight, II-57, II-63
 - low-cost, I-373
 - phase-controlled, V-267
 - soft-start, 800-W, I-376, III-304
 - tandem, II-312
 - triac, I-375, II-310, III-303
 - dissolver, solid-state, III-304
 - drivers, lamp drivers, I-380
 - flip-flop independent design, IV-160
 - low-frequency flasher/relay, I-300
 - MOS lamp driver, V-269
 - optical coupling, III-413
 - neon lamps, I-379, V-270, V-459
 - short-circuit-proof, II-310
 - emergency light, I-378, I-581, II-320, III-317, III-415, IV-250
 - exposure meter, photo enlarger, V-438
 - flame monitor, III-313
 - flasher, dark-activated, V-195
 - floodlamp power, I-373
 - fluorescent-lamp high-voltage power supplies, IV-411, V-444, V-447, VI-500
 - fringe counter, VI-300
 - halogen lamp protector, V-271
 - holiday lights sequencer, V-264-265
 - indicator-lamp driver, optically coupled, III-413
 - infrared circuits (*see* infrared circuits; remote control)
 - interruption detector, I-364
 - inverter, fluorescent, 8-W, III-306
 - key illuminator, V-333
 - lamp pulser, VI-227
 - lamp timer, VI-649
 - LEDs (*see* LED circuits)
 - level of light, I-365, I-367, I-376, I-377, I-380, I-389, III-313, III-316
 - life-extender for lightbulbs, III-302
 - light meter, VI-308, VI-350
 - light-bulb changer, automatic design, IV-253
 - lights-on warning, IV-58, IV-62, IV-250
 - light-seeking robot, II-325
 - logarithmic light sensor, I-366
 - logic circuit, I-393
 - machine vision illumination stabilizer, II-306
 - marker light, III-317
 - meters, light-meters, I-382, I-383, V-305
 - photo enlargers, V-434-435
 - modulator, III-302
 - monostable multivibrator, light-controlled, VI-303
 - monostable photocell, self-adjust trigger, II-329
 - mooring light, automatic, II-323
 - name in lights, VI-379
 - neon Christmas light flashers, VI-225
 - neon light drivers, I-379, V-270, V-459, VI-198
 - night lights
 - automatic, I-360, III-306
 - telephone-controlled, III-604
 - night-vision illuminator, IR, VI-265
 - night-vision scope power supply, VI-501
 - on/off relay, I-366
 - on/off reminder
 - automotive lights, I-109
 - with ice alarm, I-106
 - one-shot timer, III-317
 - optical interruption sensor, IV-366
 - oscillator, light-controlled, V-279
 - outdoor light control, V-275
 - phase control, II-303, II-305
 - photo alarm, II-319
 - photocell, monostable, self-adjust trigger, II-329
 - photocurrent integrator, II-326
 - photodiode amplifier, VI-301, VI-302
 - photodiode log converter/transmitter, VI-312
 - photodiode sensor amplifier, II-324
 - photoelectric controller, IV-369
 - photoelectric sensor, V-277
 - photoelectric switches, II-321, II-326, III-319
 - phototransistor, V-279
 - porch light control, V-266, V-276
 - projector-lamp voltage regulator, II-305
 - power outage light, line-operated, III-415
 - pulse-generation interruption, I-357
 - receivers, LED lightwave communications, VI-310
 - relays, I-366, V-275, V-278, V-279, VI-304
 - remote-controller, I-370
 - robot
 - eyes, II-327
 - light-seeking robot, II-325
 - running light sequencer, V-269
 - sensors, I-367
 - ambient-light ignoring, III-413
 - back-biased GaAs LED, II-321
 - dc servo, VI-300
 - logarithmic, I-366
 - multiple-input, V-273
 - optical sensor-to-TTL interface, III-314
 - photoelectric, V-277

- sequencer, V-263,
 - holiday lights, V-264-265
 - pseudorandom, III-301
 - running light, V-269
 - shimmering light, V-268
 - short-circuit proof lamp driver, II-310
 - signal conditioner, photodiode design, II-330
 - solar power supply, VI-311, VI-312
 - solid-state light sources, V-282-283
 - sound-controlled lights, I-609, V-552
 - speed controller, IV-247
 - starry light, I-579
 - strobe light, VI-468
 - high-voltage power supplies, IV-413
 - photo strobe, V-435, V-437
 - random LED, VI-224
 - trigger, V-436
 - variable, III-589-590
 - sun tracker, III-318, VI-299, VI-312
 - switches, II-320, III-314
 - adjustable, I-362
 - capacitance switch, I-132
 - dark-activated, V-274, V-276
 - light-/dark activated, V-274
 - light-activated, self-latching, V-278
 - light-controlled, II-320, III-314
 - photoelectric, II-321, II-326, III-319
 - solar triggered, III-318
 - zero-point triac, II-311
 - tachometer adapter, VI-298
 - traffic light controller, VI-298, VI-305
 - transmitter, LED lightwave communications, VI-309
 - telephone in-use light, II-625
 - three-way light control, IV-251
 - touch lamp, three-way, IV-247
 - triac circuit, V-268
 - triac controller, V-267, V-271
 - triac switch, inductive load, IV-253
 - turn-off circuit, SCR capacitor design, IV-254
 - twilight-triggered circuit, II-322
 - video, low-level video IF amplifier, I-687-689
 - voltage regulator for projection lamp, II-305
 - wake-up call light, II-324
 - warning lights, II-320, III-317
 - light-seeking robot, II-325
 - limit comparators/detectors, I-156, III-106
 - alarm, high/low, I-151
 - double ended, I-156, I-230, I-233, II-105
 - micropower, I-155
 - frequency-limit detector, II-177
 - limiters, III-320-322, IV-255-257
 - audio limiter, V-335
 - clipper/limiter, IV-355
 - low-distortion, II-15
 - dynamic noise reduction circuit, III-321
 - hold-current, solenoid driver, III-573
 - noise, II-395, III-321
 - one-zener design, IV-257
 - output, III-322
 - power-consumption, III-572
 - transmit-time limiter/limer, IV-580
 - voltage limiter, adjustable, IV-256
 - line amplifiers, III-37
 - duplex, telephone, III-616
 - RIAA line amp/driver, VI-77
 - universal design, IV-39
 - line drivers, I-262
 - 50-ohm transmission, II-192
 - 600-ohm balanced, II-192
 - audio signal amplifiers, V-54
 - full rail excursions in, II-190
 - high-output 600-ohm, II-193
 - impedance-matched with 75 Ohm load, VI-197
 - low-distortion composite 100 mA, VI-200
 - line receiver, balanced, VI-552
 - line receiver, dual-inverter, VI-542
 - shield/line driver, high-speed, VI-198
 - stereo line driver, VI-198
 - synchronized, III-174
 - video amplifier, III-710
 - video line driver, VI-683
 - video line receiver, VI-550
 - line-dropout detector, II-98
 - line-frequency square wave generator, II-599
 - line receivers, VI-542, VI-552
 - digital data, III-534
 - low-cost, III-532
 - line-sync, noise immune 60 Hz, II-367
 - line-current detector/monitors, III-341
 - optically coupled, III-414
 - line-hunt touch switch, III-664
 - line-synchronized driver circuit, III-174
 - line-voltage announcer, ac, III-730
 - line-voltage monitor, III-511
 - line-voltage-to-multimeter adapter, V-312
 - linear amplifiers
 - 1.2-kW 144-MHz, VI-20
 - 2-30 MHz, 140W PEP amateur radio, I-555
 - 100 W PEP 420-450 MHz push-pull, I-554
 - 160 W PEP broadband, I-556
 - amateur radio, 2-30 MHz 140-W, III-260
 - audio power amplifiers, V-51
 - CMOS inverter, II-11
 - inverter, linear amp from inverter, II-11
 - micropower, VI-73
 - rf amplifiers
 - 6-m, 100 W, IV-480-481
 - 903 MHz, IV-484-485
 - ATV, 10-to-15 W, IV-481
 - linear couplers
 - ac analog, II-412
 - analog, II-413
 - dc, II-411
 - optocoupler, instrumentation, II-417
 - linear IC siren, III-564
 - linear ramp generator, II-270
 - link, fiberoptic, III-179
 - liquid-level detectors (*see* fluid and moisture detectors)
 - lithium batteries
 - charger for, II-67
 - state of charge indicator for, II-78
 - little dipper dip meter, II-183
 - load-sensing circuits, V-284-285
 - locator, lo-parts treasure, I-409
 - lock detector, VI-176-177
 - locks, electronic, II-194-197, IV-161-163, VI-203-205
 - combination, I-583, II-196
 - digital entry lock, IV-162, V-157
 - frequency-based lock, VI-204
 - keyless design, IV-163
 - lock detector, VI-176-177
 - three-dial combination, II-195
 - locomotive whistle, II-589
 - logarithmic amplifiers, I-29, I-35, II-8, VI-56
 - dc to video, I-38
 - log-ratio amplifier, I-42
 - logarithmic converter, fast, I-169
 - logarithmic light sensor, I-366
 - logarithmic sweep VCO, III-738
 - logic/logic circuits, VI-313-316
 - amplifiers, logic amplifiers, II-332-335
 - low-power binary, to 10n gain
 - low-frequency, II-333
 - low-power inverting, digitally selectable gain, II-333
 - low-power noninverting, digitally selectable input and gain, II-334
 - precision, digitally programmable input and gain, II-335
 - programmable amplifier, II-334
 - AND gate, VI-315
 - audible pulses, II-345
 - chip tester, VI-334
 - combinatorial logic multiplexer, VI-315
 - converter, TTL to MOS, I-170
 - four-static, single LED indicator, II-361
 - isolation and zero voltage switching, II-415
 - level shifter, negative-to-positive supply, I-394
 - light-activated, I-393
 - line monitor, III-108
 - logic control for 78xx regulator, VI-562
 - overvoltage protection, I-517
 - power supply, 3.3-V from 5-V, VI-492
 - probes, logic probes, I-520, I-525, I-526, IV-430-431, IV-434, VI-522, VI-523
 - CMOS, I-523, I-526, III-499
 - digital, III-497, V-310
 - four-way operation, IV-432
 - memory-tester, installed, I-525
 - single-IC design, IV-433
 - three-in-one set: probe, signal tracer, injector, IV-429
- pulse generator for logic-troubleshooting, IV-436
- pulser, III-520, V-489
- regulator, 5-V, with electronic shutdown, VI-496
- relay AND circuit, VI-316
- relay OR circuit, VI-316
- signals, long delay line for, III-107
- sine wave oscillator, VI-440
- state change indicator, VI-314
- testers
 - audible, III-343, V-313
 - TTL, I-527
- translators, logic-level translators, IV-242
- long-duration timer, PUT, II-675
- long-range object detector, III-273
- loop antennas
 - 3.5 MHz, IV-12-13

logic/logic circuits *continued*
 dual band, 80-160 m, V-32
 preamp, V-38
 loop oscillators, VI-385
 loop transmitter, remote sensors, III-70
 loop-thru video amplifier, IV-616
 loudness controls, II-46, II-47
 amplifier, loudness amp, II-46
 balance amplifier with, II-395
 loudspeakers
 coupling circuit, I-78
 horn as loudspeaker, IV-54
 protector circuit, V-483
 remote link, I-343
 low-distortion input selector for audio use, II-38
 low-frequency oscillators, III-428
 crystal, I-184, II-146
 oscillator/flasher, II-234
 Pierce oscillator, III-133
 TTL oscillator, II-595
 low-pass filters, I-287
 active, V-178, V-181, V-188
 digitally selected break frequency, II-216
 fourth-order, V-184
 amplifier, VI-49
 Butterworth, V-180, V-181
 Chebyshev, fifth-order, multi-feedback, II-219
 clock-tunable, monolithic, 1 mV, V-187
 pole-active, I-295
 fast-response, fast settling, IV-168-169
 fast-settling, precision, II-220
 precision, fast settling, II-220
 Sallen Key, VI-221
 10 kHz, I-279
 active, IV-177
 equal component, I-292
 second order, I-289
 second-order, V-188
 second order Sallen-Key, I-289
 unity-gain second-order, V-187
 variable, V-186
 voltage-controlled, VI-219
 low-voltage alarm/indicator, I-224, II-493, III-769
 low-voltage power disconnect, II-97
 LVDI circuits, II-336-339, III-323-324
 driver demodulator, II-337
 signal conditioner, II-338

M

machine vision, illumination stabilizer for, II-306
 magnetometer, II-341
 magnets
 current sensor, magnetic currents, III-341
 electromagnetic-field sensor, V-308
 permanent-magnet detector, IV-281
 preamplifiers, magnetic, I-89, I-91, III-37, III-673, IV-35, IV-36
 proximity sensor, V-308
 transducer, magnetic transducer, I-233
 mains-failure indicator, IV-216
 marker generator, III-138
 marker light, III-317
 mathematical circuits, III-325-327, IV-258-263, V-286-288, VI-317-326

adder circuits, III-327
 binary, fast-action, IV-260-261
 averaging circuit, VI-324
 bridge linearizing function, VI-321
 difference of squares, VI-323
 divider circuits, IV-150-156
 binary chain, I-258
 divide-by-2-or-3 circuit, IV-154
 divide-by-N
 1+ GHz, IV-155
 1.5+ divide-by-n, IV-156
 CMOS programmable, I-257
 7490-divided-by-n, IV-154
 divide-by-odd number, IV-153
 frequency dividers, I-258, II-251, II-254, III-213-218, III-340, III-768
 1.2 GHz, III-129
 10-MHz, III-126
 clock input, IV-151
 decade, I-259
 divide-by-1.5, III-216
 low-cost, III-124
 low-frequency, II-253
 preamp, III-128
 programmable, IV-152-153
 staircase generator and, I-730
 tachometer and, I-310
 odd-number counter and, III-217
 one trim, III-326
 pulse, non-integer programmable, II-511, III-226
 minimum/maximum selector, four-input, V-332
 multiplier circuits, IV-325, VI-325
 low-frequency multiplier, IV-325
 precise commutating amp, IV-262-263
 voltage multipliers, IV-631-637
 2,000 V low-current supply, IV-636-637
 10,000 V dc supply, IV-633
 corona wind generator, IV-633
 doublers, III-459, IV-635
 cascaded, Cockcroft-Walton, IV-635
 triac-controlled, III-468
 laser power supply, IV-636
 negative-ion generator, high-voltage, IV-634
 tripler, low-current, IV-637
 multiplier/divider, VI-318, VI-322
 percentage-deviation ratio computer, VI-326
 polar-to-rectangular converter/pattern generator, radio direction, V-288
 polynomial generator, V-287
 root extractor, V-207, V-288
 sin approximation, VI-323
 slope integrator, programmable, IV-259
 square-root circuit, VI-319, VI-320, VI-322
 subtractor, III-327
 MC1330/MC1352 television IF amplifier, I-688
 measurement/test circuits (*see also* monitors; probes), II-340, III-268-270, III-328-348, IV-210-218, IV-264-311, V-230-232, V-289-321, VI-258-260, VI-327-363
 100 K megohm dc, I-624
 3-in-1 test set, III-330
 555 circuits, LED output indicator, VI-260
 absolute-value circuit, IV-274

ac hot wire, I-581
 ac-current indicator, IV-290
 ac-power indicator, LED display, IV-214
 ac/dc indicator, IV-214
 ac outlet tester, V-318
 ac power monitor, VI-351
 ac wiring locator, V-317
 ac-watts calculator, V-304
 accelerometer, VI-345
 acoustic-sound receiver, IV-311
 acoustic-sound transmitter, IV-311
 activity tester, crystal oscillators, V-138
 alarm and, I-337
 altimeter, digital, V-296
 ammeter, low-current, V-307
 anemometer, hot-wire, III-342
 atmosphere noise monitor, VI-370
 audible logic tester, III-343
 audible TTL, I-524
 audio amplifier tester, VI-343
 audio frequency meter, I-311, V-305, V-320, VI-335
 audio millivolt, III-767, III-769
 audio power, I-488
 audio-rf signal tracer, I-527
 automatic contrast, I-479
 automotive electrical tester, IV-45
 automotive-temperature indicator, PTC thermistor, II-56
 B field measurer, IV-272
 balance indicator, IV-215
 balance meter for stereo, V-583
 barometer, IV-273, VI-338
 battery indicators/testers, I-108, I-121, I-122, I-124, IV-74, IV-78, IV-79
 beat frequency, I-336
 breath alert alcohol tester, III-359
 broadband ac active rectifier, IV-271
 buzz box continuity checker, I-551
 cable tester, III-539, V-299
 calibrator (*see* calibrators)
 capacitance buffer
 low-input, III-498
 stabilized low-input, III-502
 capacitance meters, I-400, II-91-94, III-75-77, VI-340
 A/D, 3.5 digit, III-76
 capacitance-to-voltage, II-92
 digital, II-94
 capacitor testers, IV-265, IV-279, V-306, VI-358
 clamp-on-current compensator, II-501
 CMOS logic, I-523
 continuity testers, I-550, I-551, II-342, II-533, II-534, II-535, III-345, III-538-540, IV-287, IV-289, IV-295, IV-296, V-293, V-317, V-319
 crystal tester, I-178, I-186, II-151, V-139
 current meters and monitors, I-203, II-152-157, III-338, VI-259, VI-355
 ac current indicator, IV-290
 current sensing in supply rails, II-153
 electrometer amplifier with overload protection, II-155
 Hall-effect sensors, III-255, IV-284
 high-gain current sensor, IV-291
 picoammeter, I-202, II-154, II-157, III-338
 guarded input, II-156

range ammeter, six-decade, II-153, II-156
 curve tracer, I-397, IV-274, V-300
 CW offset indicator, IV-213
 deviation meter, IV-303
 dial pulse, III-613
 digital frequency meter, III-344
 digital multimeter (DMM), IV-291, V-291
 digital voltmeters (DVM), III-4
 3.5-digit, I-713, III-761
 3.75-digit, I-711
 4.5-digit, I-717, III-760
 adapter for PC, V-310
 auto-calibrate circuit, I-714
 automatic nulling, I-712
 interface and temperature sensor, II-647
 LED readout, IV-286
 temperature sensor and DVM, 647
 diode tester, I-401, I-402, I-406, II-343, III-402
 dip meters, I-247, II-182-183
 bandswitched, IV-298
 basic grid, I-247, IV-298
 dual gate IGFET, I-246
 little dipper, II-183
 varicap tuned FET, I-246
 direction-of-rotation circuit, III-335
 diode-curve tracer, IV-274
 diode-matching circuit, IV-280
 dosage rate, I-534
 driver, meter-driver rf amplifier, I-MHz, III-545
 duty-cycle meter, III-329, IV-265, IV-275, IV-280
 dwell meter, I-102, III-45
 E, T, and R measurement/test circuits, IV-283-296
 ECG amplifiers with right leg drive, VI-354
 electrolytic-capacitor reforming circuit, IV-276
 electromagnetic-field sensor, V-308
 electrometer, IV-277
 electroscope, VI-341
 electrostatic detector, III-337
 ELF monitor, VI-336
 energy consumption monitor, V-290
 expanded-scale analog meters, II-186, III-774, IV-16
 FET probe, III-501
 FET voltmeter, III-765, III-770
 field-strength meters, II-208-212, III-182-183, IV-164-166 V-174-176
 1.5-150 MHz, I-275
 adjustable sensitivity indicator, I-274
 high-sensitivity, II-211
 LF or HF, II-212
 microwave, low cost, I-273
 rf sniffer, II-210
 sensitive, I-274, III-183
 signal-strength meter, IV-166
 transmission indicator, II-211
 tuned, I-276
 UHF fields, IV-165
 untuned, I-276
 filter analyzer, audio filters, IV-309
 flash exposure meter, I-484, III-446
 frequency comparator, VCO and input, VI-353
 frequency counter, III-340, IV-300, VI-360
 frequency divider, VI-10-MHz
 frequency standard, VI-341
 frequency meters, I-310, II-249-250, IV-282, IV-301
 analog, V-307
 audio, I-311
 linear, I-310
 low-cost, II-250
 power, II-250
 power-line, I-311
 frequency shift keyer tone generator, I-723
 frequency standard, 10-MHz, VI-361
 gate dip oscillator, VI-344, VI-346
 Geiger counters, I-536-537, II-489, II-514, V-217-219
 general purpose rf detector, II-500
 go/no-go test circuits, I-401, I-157
 grid-dip meters, I-247, IV-298
 ground, I-580, II-345
 ground-noise, battery-powered, III-500
 harmonic distortion analyzer, V-291, VI-357
 meter, V-312
 impedance checker, V-136
 in-use indicator, telephone, II-629
 inductance meter, linear, V-316, VI-330, VI-358
 infrared detector, low-noise, II-289
 injectors, IV-429
 ion detector, VI-267, VI-533
 ion-sensing electroscope, VI-287
 high-frequency and rf tester, IV-297-303
 LC checker, III-334
 LED meters, I-251, III-347
 level indicators (see fluid and moisture, level)
 line-current monitor, III-341
 light meters, I-382, I-383, V-302, VI-308, VI-350
 line-voltage-to-multimeter adapter, V-312
 logic chip tester, VI-334
 logic probes, I-520, I-525, I-526, IV-430-431, IV-434
 CMOS, I-523, I-526, III-499
 digital, III-497, V-310
 four-way operation, IV-432
 memory-tester, installed, I-525
 single-IC design, IV-433
 three-in-one test set: probe, signal tracer, injector, IV-429
 logic tester, I-527, II-345, III-343, V-313
 low-current measurement, III-345
 low-ohms adapter, IV-290
 low-voltage, III-769
 magnet/magnetic detectors, III-341, IV-266, IV-281, V-308
 magnetometer, II-341
 mains-failure indicator, IV-216
 measuring gauge, linear variable differential transformer, I-404
 meter tester, IV-270
 metronomes, I-411-413, II-353-355, III-353-354, IV-312-314, V-392
 microammeter, dc, four-range, IV-292
 microfarad counter, IV-275
 microvolt, II-499
 millivoltmeters, III-767, III-769, IV-289, IV-294, IV-295
 ac, I-716
 audio, III-767, III-769
 dc, IV-295
 four-range, IV-289
 high-input impedance, I-715
 LED readout, IV-294
 minute marker, VI-337
 model car derby winner indicator, VI-259
 modulation monitor, III-375, IV-299
 mono audio-level meter, IV-310
 motion sensor, unidirectional, II-346
 motor hour, III-340
 motorcycle tune-up aid, VI-359
 multiconductor-cable tester, IV-288
 multimeters, IV-291, IV-293
 nanoammeter, VI-349
 negative voltage reference, VI-331
 noise generator, IV-308
 ohmmeters, I-549, III-540, IV-290
 On indicator, IV-217
 on-the-air, III-270
 op-amp dc offset shift tester, V-319
 optical light probe, IV-369
 oscilloscope adapter, four-trace, IV-267
 overspeed, I-108
 overvoltage protection, I-150, I-517, II-96, II-107, II-496, III-513, III-762, IV-389
 paper sheet discriminator, copying machines, III-339
 peak detectors, II-174, II-175, II-434-436, III-771, IV-138, IV-143
 analog, with digital hold, III-153
 decibel peak meter, III-348
 digital, III-160
 high-bandwidth, III-161
 high-frequency peak, II-175
 high-speed peak, I-232
 LED design, peak meter, III-333
 level detector, I-402
 low-drift, III-156
 negative, I-225, I-234
 op amp, IV-145
 positive, I-225, I-235, II-435, III-169
 true rms, I-228
 ultra-low-drift peak, I-227
 voltage, precision, I-226
 wide-bandwidth, III-162
 wide-range, III-152
 pH tester, I-399, III-501
 phase detection/manipulation circuits
 detectors, I-406, I-476, II-344, II-439, II-441, II-442, III-440-442, IV-127
 10-bit accuracy, II-176
 digital VOM, IV-277
 phase-difference detector, 0 to 180-degree, II-344
 phase selector/sync rectifier/balanced modulator, III-441
 sequencers, phase sequence, I-476, II-437-442, III-441
 rc circuit, phase sequence reversal detection, II-438
 reversal, rc circuit to detect, II-438
 three-phase tester, II-440
 shifters, phase shifters, IV-647
 0-180 degrees, I-477
 0-360 degrees, I-477
 single transistor design, I-476
 splitter, precision, III-582

- measurement/test circuits *continued*
- tracker, three-phase square wave generator, II-598
 - picammeters, I-202, II-154, III-338
 - circuit for, II-157
 - guarded input circuit, II-156
 - PIN diode tester, VI-353
 - polarity indicator, V-231
 - power gain meter, 60 MHz, I-489
 - power line frequency tester, I-311
 - power meter, I-489, VI-333
 - power supply test load, constant-current, IV-424
 - power supply, 10-MHz frequency standard, VI-335
 - power transformer tester, VI-354
 - prescaler, 650 MHz amplifying, II-502
 - pressure gauge, digital, V-314
 - probes, 4-to-220 V, III-499
 - process controller, VI-4 to 20-mA, VI-355
 - proximity sensor, magnetic, V-308
 - pulse-width meter, III-336
 - QRP SWR bridge, III-336
 - radon detectors, VI-531-533
 - RC decade box, V-294-295
 - receiver-signal alarm, III-270
 - receiver signal-strength indicator, VI-260
 - reference circuit, VI-339
 - reflectometer, I-16
 - remote-control infrared device, IV-228
 - remote meters, VI-347
 - resistance measurement, II-342, IV-285, VI-335
 - resistor simulator, 100-W, VI-352
 - resistors, programmable, VI-363
 - resistance/continuity meters (*see* continuity tester, above)
 - rf bridge, V-303
 - rf output indicator, IV-299
 - rf power indicator, I-16, III-332, VI-348
 - rf probe, I-523, III-498, III-502, IV-433
 - rf test oscillator, V-412
 - rf voltmeter, III-766
 - rf-actuated relay, III-270
 - S meter for communications receivers, V-311
 - scale, electronic, V-297
 - SCR tester, III-344
 - short-tester, V-313, V-315
 - shutter, I-485
 - signal generators, V-309
 - AM broadcast-band, IV-302
 - AM/FM, 455 kHz, IV-301
 - signal strength meter, III-342, IV-166
 - signal tracer, IV-429, V-309
 - signal tracking signal generator, VI-356
 - simulated, I-417
 - single injector-tracer, II-500
 - soil moisture, III-208
 - sound-level meters, III-346, IV-305, IV-307
 - telephone, III-614
 - sound sensor, IV-218
 - sound subcarrier generator, VI-358
 - sound-test circuits (*see also* sound generators), IV-304
 - speedometer, bike, IV-271, IV-282
 - static detector, IV-276
 - stereo test circuits
 - audio-level meter, IV-310
 - audio-power meter, III-331, IV-306
 - balance indicator, I-618-619
 - reception indicator, III-269
 - stud finder, III-339
 - strain-gauge sensor, VI-336
 - supply-voltage monitor, V-320
 - suppressed zero, I-718
 - SWR power, I-16, I-22, IV-269
 - tachometers, I-94, I-100, I-102, II-175, III-335, III-340, III-347, V-65, V-596-598
 - analog readout, IV-280
 - calibrated, III-598
 - closed loop feedback control, II-390
 - digital readout, II-61, III-45, IV-268-269, IV-278
 - dwll meter/tachometer, III-45
 - feedback control, II-378, II-390
 - frequency counter, I-310
 - low-frequency, III-596
 - minimum-component design, I-405
 - motor speed controllers, II-378, II-389
 - optical pick-up, III-347
 - set point, III-47
 - telephone
 - in-use indicator, II-629, IV-560, IV-563
 - line-tester, V-615
 - off-hook, I-633
 - temperature (*see* temperature-related circuits)
 - temperature indicator, IV-570
 - test driver for hobby servos, VI-197
 - test probe, 4-220 V, III-499
 - tester, IV-270
 - thermometers, III-637-643
 - three-in-one set, logic probe, signal tracer, injector, IV-429
 - three-phase tester, II-440
 - tilt meter, III-644-646, V-302
 - tone, digital IC testing, II-504
 - transistor tester, I-401, IV-281, V-306
 - transistor-matching circuit, VI-339
 - transmitter-output indicator, IV-218
 - tri-color indicator, V-232
 - TTL logic tester, I-527
 - universal test probe, IV-431
 - UHF source dipper, IV-299
 - undervoltage, battery operated equipment, I-123
 - universal test probe, IV-431
 - VCR head amplifier tester, VI-48
 - vibration meter, I-404
 - video-signal amplitude measurer, V-309
 - visual modulation, I-430
 - visual level, III-269
 - voice level meter, VI-194
 - voltage level indicators, I-335, I-337, I-338, I-718, III-758-772, V-301, V-315
 - voltage probes, V-474
 - voltmeters, III-758
 - 3.5 digit, I-710, I-713, III-761
 - 4.5-digit, III-760
 - 5-digit, III-760
 - ac, I-716, III-765, III-772
 - add-on thermometer for, III-640
 - bar-graph, I-99, II-54
 - dc, III-762, III-763, V-301
 - digital voltmeters (DVM), III-4
 - 3.5-digit, common anode display, I-713
 - 3.5-digit, full-scale, four-decade, III-761
 - 3.75-digit, I-711
 - 4.5-digit, III-760
 - 4.5-digit, LCD display, I-717
 - auto-calibrate circuit, I-714
 - automatic nulling, I-712
 - interface and temperature sensor, II-647
 - LED readout, IV-286
 - temperature sensor and DVM, 647
 - FET, I-714, III-765, III-770
 - high-input resistance, III-768
 - JFET, V-318
 - LED expanded scale, V-311
 - millivoltmeters (*see* millivoltmeters)
 - rf, I-405, III-766
 - single-chip digital, VI-329
 - voltmeters (VOM)
 - field strength, I-276
 - phase meter, digital readout, IV-277
 - volume indicator, audio amplifier, IV-212
 - VOR signal simulator, IV-273
 - VU meters, I-715, II-487, III-487, IV-211
 - watch tick timer, V-292
 - water-level measurement circuit, IV-191
 - wattmeter, optical isolator, VI-342
 - wave generator, three-phase digital, VI-343
 - wavemeter, tuned RF, IV-302
 - wideband test amplifier, IV-303
 - wire tracer, II-343
 - zener diode test set, V-321
 - zener diode tester, I-400, I-406
 - zero center, FM receivers, I-338
 - medical electronic circuits, II-347-349, III-349-352
 - biomedical instrumentation
 - differential-amp, III-282
 - breath monitor, III-350
 - ECG amplifiers with right leg drive, VI-354
 - EKG simulator, three-chip, III-350
 - heartbeat transducer, VI-387
 - heart rate monitor, II-348, II-349, V-342
 - preamplifier for, II-349
 - stimulator, constant-current, III-352
 - stimulus isolator, III-351
 - thermometer, implantable/ingestible, III-641
 - megaphone circuit, VI-93
 - melody generator, single-chip design, IV-520
 - memo alert, V-352
 - memory-related circuits
 - EEPROM pulse generator, 5V-powered, III-99
 - flash memory programming supply, +12 volt, VI-138
 - lithium backup battery replacement, VI-120
 - memory protector/power supply monitor, IV-425
 - memory-saving power supply, II-486
 - transceiver memory backup, VI-28
 - messenger circuit

- Morse code, VI-406-407
 - single-chip, VI-373
 - metal detectors, II-350-352, IV-137, V-322-324
 - low-cost design, V-323
 - micropower, I-408
 - pipe detector, V-323
 - meters (*see* measurement/test circuits)
 - methane concentration detector, linearized output, III-250
 - metronomes, I-413, II-353-355, III-353-354, IV-312-314, V-392, VI-364-366
 - ac-line operated unijunction, II-355
 - accentuated beat, I-411
 - audible metronome, VI-365
 - downbeat-emphasized, III-353-354
 - electronic, IV-313
 - low-power design, IV-313
 - novel design, IV-314
 - sight and sound, I-412
 - simple, II-354
 - top octave generator, V-393
 - version II, II-355
 - visual metronome, VI-366
 - microammeter, dc, four-range, IV-292
 - microcontroller, musical organ, preprogrammed single-chip, I-600
 - microphone circuits
 - AM-modulated oscillator for wireless microphones, VI-450
 - amplifiers, I-87, III-34
 - electronic balanced input, I-86
 - buffer amplifiers, high-Z, VI-125
 - electret, preamp circuit, V-21
 - external mic circuit for transceivers, V-351
 - FM wireless, III-682, III-685, III-691
 - high-impedance input circuit, VI-81
 - mini-megaphone circuit, VI-93
 - mixer, II-37, V-363, V-364
 - parabolic dish mikes, electronic-ear amp, VI-82
 - preamplifiers, II-45, IV-37, IV-42
 - balanced mic, VI-77
 - dynamic mic, VI-76, VI-79
 - low-impedance, IV-41
 - low-voltage, VI-56
 - tone control for, II-687
 - transformerless, unbalanced input, I-88
 - transformerless, unbalanced input, I-88
 - underwater microphone, VI-379
 - wireless, I-679, IV-652-654, VI-661
 - microprocessors (*see* computer circuits)
 - microvolt comparators
 - dual limit, III-89
 - hysteresis-including, III-88
 - microvolt probe, II-499
 - microwave amplifiers, IV-315-319
 - 5.7 GHz, IV-317
 - bias supply for preamp, IV-318
 - preamplifiers
 - 2.3 GHz, IV-316
 - 3.4 GHz, IV-316
 - bias supply, IV-318
 - single-stage, 10 GHz, IV-317
 - two-stage, 10 GHz, IV-319
 - microwave field strength meter, I-273
 - MIDI (*see* musical circuits)
 - Miller oscillator, I-193
 - millivoltmeters, III-767, III-769, IV-289, IV-294, IV-295
 - ac, I-716
 - audio, III-767, III-769
 - dc, IV-295
 - four-range, IV-289
 - high-input impedance, I-715
 - LFD readout, IV-294
 - mini-stereo audio amplifiers, III-38
 - minimum/maximum selector, four-input, V-332
 - mixers, III-367-370, IV-330-336, V-359-364, VI-392-393
 - 1-MHz, I-427
 - audio, I-23, I-59, II-35, IV-335, V-362, V-364
 - CMOS, I-57
 - common-source, I-427
 - digital mixer, IV-334
 - duplexer, IV-335
 - doubly balanced, I-427
 - dynamic audio mixer, IV-331
 - four-channel, I-56, I-60, II-40, III-369, IV-333
 - four-input, I-55, IV-334
 - guitar mixer, low-noise, four-channel, V-360-361
 - HF transceiver/mixer, IV-457
 - hybrid, I-60
 - input-buffered, III-369
 - local oscillator, double-balanced mixer, V-415
 - microphone, II-37, V-363, V-364
 - mixer/oscillator for AM receivers, V-412
 - multiplexer, I-427
 - one-transistor design, I-59
 - passive, I-58
 - preamplifier with tone control, I-58
 - signal combiner, III-368
 - silent audio switching, I-59
 - sound amplifier and, II-37
 - stereo mixer, pan controls, IV-332
 - unity-gain, four-input, IV-334
 - utility-design mixer, IV-336
 - universal stage, III-370
 - video, high-performance operation, IV-609
 - mobile equipment, 8-amp regulated power supply, II-461
 - model and hobby circuits, IV-337-340, VI-394-396
 - controller, model-train and/or slot-car, IV-338-340
 - railroad crossing flasher, VI-395
 - railroad track control signal, VI-396
 - rocket launcher, II-358
 - modems
 - power-line, carrier-current circuit, III-82
 - power line modem for computer control, VI-474
 - protector, V-479, V-482
 - modulated readback systems, disc/tape phase, I-89
 - modulation indicator/monitor, I-430
 - CB, I-431
 - modulators, I-437, II-368-372, III-371-377, V-365-367, VI-397-403
 - 455-kHz, V-366
 - +12V dc single supply, balanced, I-437
 - AM, I-438, II-370
 - balanced, III-376, III-441
 - digital pulse width modulation, VI-400-401
 - double-sideband suppressed-carrier, III-377
 - DSB modulator, four-quadrant, VI-402
 - FM, V-366, V-367
 - high-frequency, varactorless, VI-398
 - linear (AM) amplitude modulator, VI-402
 - linear pulse-width, I-437
 - monitor for, III-375
 - musical envelope generator, I-601
 - pulse-position, I-435, III-375
 - pulse-width, I-435, I-436, I-438-440, III-376, IV-326, VI-402
 - rf, I-436, II-369, III-372, III-374
 - saw oscillator, III-373
 - TTL oscillator for television display, II-372
 - TV, I-439, II-433, II-434
 - VHF, I-440, III-684
 - video, I-437, II-371, II-372, VI-399, VI-403, VI-399
- moisture detector (*see* fluid and moisture detectors)
- monitors for computers (*see* computer circuits)
- monitors (*see also* alarms; fluid and moisture; light-controlled circuits; motor control circuits; speed controllers; temperature-related circuits; tone controls), V-368-372
 - ac power line monitor, VI-473
 - acid rain, III-361, V-371
 - baby monitor, V-370-371
 - battery monitors, I-106, I-222, II-74-79, III-60-67, IV-73-80
 - bird feeder monitor, V-371
 - blinking phone light, II-624
 - breath monitor, III-350
 - current, III-255, IV-284
 - alarm and, III-338
 - directional signals, auto, III-48
 - door-ajar, automotive circuits, III-46
 - duty cycle, III-329, IV-275
 - flames, III-313
 - home security system, I-6
 - line-current, III-341
 - line-voltage, III-511
 - logic line, III-108
 - modulation, III-375, IV-299
 - overvoltage protection, I-150, I-517, II-96, II-107, II-496, III-513, III-762, IV-389
 - power-supply monitors, II-491-497, III-493-495, IV-422-427
 - backup supply, drop-in main-activated, IV-424
 - booster/buffer, boosts reference current, IV-425
 - circuit breaker, trip circuit, IV-423
 - connections monitor, ac lines, III-510
 - fault monitor, single-supply, III-495
 - memory protector/supply monitor, IV-425
 - polarity-protection relay, IV-427
 - SCR design, IV-385
 - test load, constant-current, IV-424
 - triac for ac-voltage control, IV-426
 - tube amplifier, high-voltage isolation, IV-426
 - voltage monitors (*see* voltage monitors)

monitors *continued*
radon detectors, VI-531-533
room monitor, V-369

monostable multivibrators, I-465, III-229, III-230, III-235, III-237, V-386, V-387, VI-700

input lockout, I-464

light-controlled, VI-309

linear-ramp, III-237

photocell, monostable, II-329

positive-triggered, III-229

TTL, monostable operation, I-464

UJT, monostable operation, I-463

video amplifier and comparator, II-268

mooring light, automatic, II-323

Morse code circuits, VI-404-409

code practice oscillator, VI-409

CW audio filter, VI-405

CW identifier, VI-408

messenger circuit, VI-406-407

MOSFETS

amplifier, high-impedance biasing, V-19

audio power amplifiers, V-47

biasing, high-impedance method, V-19

buffer amplifier, V-93

drive current booster, VI-368

driver, high-side, VI-199

frequency converter, V-123

mixer/oscillator for AM receivers, V-412

power control switch, IV-386

power inverter, III-295, V-247

push-pull amplifier, VI-55

mosquito repelling circuit, I-684

motion/proximity detectors, I-135-136, I-344, II-135, II-136, II-505-507, III-514-518, IV-341-346, V-376-377, V-484-486

acoustic Doppler motion detector, IV-343

alarm for, II-506, VI-657

auto alarm, I-9

capacitive, III-515

capacitive sensor touch switch system, VI-656

field disturbance sensor/alarm, II-507

infrared-reflection switch, IV-345

light-beam intruder-detection alarm, V-11, V-13

low-current-drain design, IV-342-343

magnetic, V-308

microwave circuit, V-377

motorcycle alarm, I-9

object detector, long-range, III-273

optical detector circuit, V-405

optical interruption sensor, IV-366

people-detector, infrared-activated, IV-225

proximity switch, infrared-activated, IV-345

relay-output, IV-345

room monitor, V-369

SCR alarm, III-517

self-biased, changing field, I-135

switch, III-517

UHF, III-516, IV-344

ultrasonic motion detector, VI-668

ultrasonic proximity detector, VI-669

unidirectional, II-316

motor control circuits, IV-347-353, V-378-381, VI-410-416

400 Hz servo amplifier, II-386

ac motors, II-375

ac servo amplifier, bridge-type, III-387

bidirectional proportional control, II-374

blender control circuit, V-379

compressor protector, IV-351

dc motors

direction controls, I-452

driver controls,

fixed speed, III-387

reversing, II-381

servo, bipolar control input, II-385

speed-controlled reversible, III-388

fiber optic controls, II-206

speed control, VI-411

direction controller, VI-413, VI-416

dc motors, I-452

series-wound motors, I-448

shunt-wound motors, I-456

stepper motor, IV-350

driver controls

ac motors

three-phase, II-383

two-phase, I-456, II-382

constant-speed, III-386

dc motors

fixed speed, III-387

reversing, II-381

servo, bipolar control input, II-385

speed-controlled reversible, III-388

N-phase motor, II-382

piezo drive, V-380

PWM, V-380

reversing, dc control signals, II-381

servo motor amplifier, I-452, II-384

stepper motors, III-390

half-step, IV-349

quarter-step, IV-350

two-phase, II-456

fiber-optic, dc, variable, II-206

hours-in-use meter, III-340

induction motor, I-454

load-dependent, universal motor, I-451

mini-drill control, IV-348

model train and/or car, I-453, I-455

phase control, hysteresis free, I-373

piezo motor drive, V-380

power brake, ac, II-451

power-factor controller, three-phase, II-388

power-tool torque, I-458

PWM motor controller, III-389

PWM servo amplifier, III-379

PWM speed control, II-376

PWM speed control/energy-recovering brake, III-380

self-timing control, built-in, universal motor, I-451

servo motor amplifier, I-452, II-384

servo system, III-384

speed control (*see* speed controllers)

start-and-run motor circuit, III-382

stepper motors, V-571-573, VI-600-602

half-step, IV-349

quarter-step, IV-350

speed and direction, IV-350

tachometers, I-94, I-100, I-102, II-175, III-335, III-340, III-347

V-65, V-596-598, VI-98, VI-298, VI-371

analog readout, IV-280

calibrated, III-598

closed loop feedback control, II-390

digital readout, II-61, III-45, IV-268-269, IV-278

dwelt meter/tachometer, III-45

feedback control, II-378, II-390

frequency counter, I-310

low-frequency, III-596

minimum-component design, I-405

motor speed controllers, II-378, II-389

optical pick-up, III-347

set point, III-47

three-phase controls, II-383, II-388

time-delay motor-control, long time, VI-413

two-phase controls, I-456, II-382

motorcycles (*see* automotive circuits)

multiburst generator, square waveform, II-88

multimeters (*see also* digital multimeters (DMM)), IV-291, IV-293

multiple-input detector, III-102

multiplexers, III-391-397, V-382-383

1-of-8 channel transmission system, III-395

analog, II-392, V-383

0/01-percent, II-392

buffered input and output, III-396

input/output buffer for, III-11

single- to four-trace converter, II-431

capacitance, II-200, II-416

combinatorial logic, VI-315

common-cathode LED-display ADC, III-764

de-, III-394

differential multiplexer, I-425, I-428, II-428

driver, high-speed line driver, I-284

eight-channel data acquisition circuit, VI-378

eight-channel mux/demux, I-426, II-115

four-channel, low-cost, III-394

frequency, III-213-218

line driver, I-264

low output impedance, VI-605

mathematical, one trim, III-326

oscilloscopes, add-on, III-437

pulse-width, III-214

resistor, II-199

sample-and-hold, three-channel, III-396

two-level, III-392

video, 1-of-15 cascaded, III-393

wideband differential, II-428

multiplier circuits, IV-325

capacitance multiplier, V-205, V-347

low-frequency multiplier, IV-325

photomultipliers, high-volt power supply, V-444, V-445

precise commutating amp, IV-262-263

resistance multiplication circuit, op amp, VI-431

- voltage multipliers, IV-631-637
 - 2,000 V low-current supply, IV-636-637
 - 10,000 V dc supply, IV-633
 - corona wind generator, IV-633
 - doublers, III-459, IV-635
 - cascaded, Cockcroft-Walton, IV-635
 - triac-controlled, III-468
 - laser power supply, IV-636
 - negative-ion generator, high-voltage, IV-634
 - tripler, low-current, IV-637
 - multivibrators, V-384-388, VI-417-419
 - 100 kHz free running, II-485
 - astable multivibrators, II-269, II-510, II-597, III-196, III-224, III-233, III-237, III-238, V-386-388, VI-418-419
 - bistable multivibrators, I-133, II-465, VI-418
 - inverter, III-103
 - debouncer, IV-108
 - flasher, I-299, II-234
 - lamp driver, IV-160
 - pushbutton trigger, V-388
 - RS flip-flop, I-395
 - SCR, II-367
 - SR flip-flop, IV-651
 - touch-triggered, I-133
 - car battery, II-106
 - CB modulation, II-431
 - CMOS, V-385
 - current, II-203
 - duty-cycle, 50-percent, III-584
 - free-running
 - 100 kHz, I-465
 - programmable-frequency, III-235
 - with op amp, V-388
 - low-frequency, III-237
 - low-voltage, II-123
 - modulation, II-430
 - monostable multivibrators, I-465, III-229, III-230, III-235, III-237, V-386, V-387
 - input lockout, I-464
 - linear-ramp, III-237
 - photocell, monostable, II-329
 - positive-triggered, III-229
 - TTL, monostable operation, I-464
 - UJT, monostable operation, I-463
 - video amplifier and comparator, II-268
 - one-shot, I-465, I-720, II-266, II-465, III-222, III-238, III-317, III-654, V-388, VI-419
 - oscilloscope, II-474
 - single-supply, III-232
 - sound level, II-403
 - square-wave generators, IV-536
 - telephone line, II-628
 - very-low-frequency, V-385
 - wideband radiation, II-535
 - music circuits (*see also* sound generators), V-389-393
 - envelope generator/modulator, IV-22
 - instrument tune-up, audio
 - generator, V-390
 - melody circuit, V-393
 - melody generator, single-chip design, IV-520
 - metronome (*see* metronomes)
 - MIDI receiver, V-392
 - MIDI transmitter, V-393
 - multi-tone generator, V-566
 - music maker circuit, III-360, IV-521
 - musical chimes, I-640
 - musical envelope, modulator, I-601, IV-22
 - octave equalizer, V-353
 - perfect pitch circuit, V-391
 - synthesizer, V-10-note, V-561
 - telephone music-on-hold circuit, V-601, V-605
 - wireless guitar transmitter, VI-661
 - mux/demux (*see* multiplexers)
- N**
- N-phase motor drive, III-382
 - NAB preamps
 - record, III-673
 - two-pole, III-673
 - NAB tape playback pre-amp, III-38
 - nanammeter, I-202, VI-349
 - NE602
 - dc power circuit, V-358
 - input/output circuits, V-355
 - negative-ion generator, IV-634
 - neon flashers, I-303
 - Christmas light flashers, VI-225
 - five-lamp, III-198
 - two-state oscillator, III-200
 - tube, I-304
 - networks
 - crossover networks, I-172-173, II-35
 - 5V, I-518
 - ac/dc lines, electronic, I-515
 - active, I-172
 - asymmetrical third order
 - Butterworth, I-173
 - electronic circuit for, II-36
 - filter, I-291
 - speech, telephone, II-633
 - ni-cad batteries, I-118
 - analyzer for, III-64
 - charger, I-112, I-116, III-57
 - 12 v, 200 mA per hour, I-114
 - current and voltage limiting, I-114
 - fast-acting, I-118
 - portable, IV-69
 - temperature-sensing, IV-77
 - thermally controlled, II-68
 - packs, automotive charger for, I 115
 - portable, III-47, IV-69
 - protection circuit, III-62
 - simpli-cad, I-112
 - temperature-sensing charger, IV-77
 - test circuit, IV-79
 - thermally controlled, II-68
 - zappers, I-6, II-66, II-68
 - night lights (*see* lights/light-activated and controlled circuits)
 - night-vision illuminator, IR, VI-265
 - night-vision scope power supply, VI-501
 - no-doze alarm, V-8
 - noise generators (*see* sound generators)
 - noise detector for ac circuits, VI-184
 - noise reduction circuits, II-393-396, III-398-401, IV-354-356, V-396-398, VI-420-424
 - amplified noise limiter for SW receivers, V-397
 - audio clipper/limiter, IV-355
 - audio dynamic system, V-397
 - audio shunt noise limiter, IV-355
 - audio squelch, II-394
 - balance amplifier with loudness control, II-395
 - blanker, IV-356
 - clipper, II-394
 - adjustable, VI-423
 - audio-powered, III-396
 - Dolby, VI-421
 - Dolby B, decode mode, III-401
 - Dolby B, encode mode, III-400
 - Dolby B/C, III-399
 - dynamic noise reduction, III-321
 - filters (*see* filters)
 - limiter, II-395, III-321, VI-423
 - low-level signal noise, V-398
 - noise generator, VI-421
 - noise-based voting circuit, VI-422-423
 - receiver application, V-398
 - shortwave receiver noise limiter, V-397
- noise monitor, VI-370
- noninverting amplifiers, I-32, I-33, I-41, III-14
 - ac power, I-79
 - adjustable gain, I-91
 - comparator with hysteresis in, I-153
 - high-frequency, 28-dB, III-263
 - hysteresis in, I-153
 - low-power, digitally selectable input and gain, II-334
 - power, I-79
 - programmable-gain, III-505
 - single supply, I-74
 - split supply, I-75
- nonselective frequency tripler, transistor saturation, II-252
- Norton amplifier, absolute value, III-11
- notch filters (*see also* filter circuits), I-283, II-397-403, III-402-404
 - 4.5 MHz, I-282
 - 550 Hz, II-399
 - 1800 Hz, II-398
- active band reject, II-401
- adjustable Q, II-398, V-179, VI-217
- audio, II-400
- bandpass and, II-223
- high-Q, III-404, V-178, VI-213, VI-217, VI-220
- RC, VI-221
- selectable bandwidth, I-281
- shortwave receiver filter, V-185
- three-amplifier design, I-281
- tunable, II-399, II-402, V-179
 - passive-bridged differentiator, II-403
 - hum-suppressing, I-280
 - op amp, II-400
 - twin-notch for 1 kHz, V-183
 - twin-T, III-403
 - Wien bridge, II-402
- NTSC gray-scale video generator, VI-679
- NTSC-to-RGB converter, VI-677
- NTSC-to-RGB video decoder, IV-613
- nuclear particle detector, I-537
- null circuit, III-69
 - op amp offset null, VI-427
- null detector, I-148, III-162
- O**
- octal D/A converter, V-350
 - ohmmeters, I-549
 - linear, III-540
 - linear scale, I-549
 - five-range, IV-290
 - ohms-to-volts converter, I-168

oil-pressure gauge, automotive, IV-44, IV-47

on/off control, I-665

on/off inverter, III-594

on/off touch switches, II-691, III-663

one-arm bandit game, VI-251

one-of-eight channel transmission system, III-100

one-shot function generators, I-465, V-388, VI-419

digitally controlled, I-720

precision, III-222

pulse generator, V-490-491

retriggerable, III-238

one-shot timers, III-654

light-controlled, III-317

voltage-controlled high-speed, II-266

op amps, II-404-406, III-405-406, IV-357-364, V-399-403, VI-425-431

x10, I-37

x100, I-37

astable multivibrator, III-224

audio amplifier, IV-33, VI-427

balanced amplifier, VI-429

bandpass filter, VI-216, VI-222

bidirectional compound op amp, IV-361

bridge connections for power op amps, VI-92

clamping for, II-22

clock circuit using, III-85

comparator, three-input and gate comparator, IV-363,

composite amplifier, V-401, V-403

compound op-amp, IV-364

current regulator, VI-430

dc offset-shift tester, V-319

differential amplifier, VI-186

driver, IV-158-159

feedback-stabilized amplifier, IV-360

free-running multivibrator, V-388

full-wave rectifier design, V-403

gain-controlled op amp, IV-361

high-gain/bandwidth, V-403

input guard for high-Z op amps, VI-428

intrinsically safe protected, III-12

inverter/rectifier, programmable, IV-364

laser driver, VI-295

logarithmic amplifier, VI-56

long RC time constants, VI-426

microphone mixer, V-364

mixer circuit, VI-393

offset null, VI-427

on/off switch, transistorized, IV-546

paralleled power op amps, VI-84, VI-429

polarity gain adjustment, V-400

power op amp, V-402

power booster, IV-358

power driver circuit, IV-158-159

pseudoground, VI-431

quad, simultaneous waveform generator using, II-259

resistance multiplication circuit, VI-431

sawtooth generator, VI-701

single potentiometer to adjust gain over bipolar range, II-406

single-supply applications, VI-430

swing rail-ray, LM324, IV-363

temperature-compensated breakpoint, nonlinear, V-19, V-401

transconductance op amp, with booster, VI-47

tunable notch filter with, II-400

V- and I-protected, V-25

variable gain, II-405, V-402

VCO driver, IV-362

video op amp circuits, IV-615

optical circuits (*see also* lasers; lights/light-activated and controlled circuits), II-407-419, IV-365-369, V-404-409

50 kHz center frequency FM transmitter, II-417

ac relay, III-418

two photon couplers, II-412

ac switcher, high-voltage, III-408

ambient light-ignoring optical sensor, III-413

CMOS coupler, III-414

communication system, II-416

couplers/optocouplers, II-409, II-417

analog coupler, linear ac, II-412

analog coupler, linear, II-413

CMOS design, III-414

dc linear coupler, II-411

instrumentation, linear, II-417

optocouplers, II-409, II-417

stable, II-409

TTL design, III-416

dc latching relay, III-417

digital transmission isolator, II-414

direction discriminator, V-408

high-sensitivity, NO, two-terminal zero voltage switch, II-414

indicator lamp driver, III-413

integrated solid state relay, II-408

interfaces, optocouplers/optoisolators, V-406-407

interruption sensor, IV-366

isolation and zero voltage switching logic, II-415

isolators/optoisolators, IV-475

driver, high-voltage, III-482

telephone status monitor using, I-626

light-detector, IV-369

line-current detector, III-414

microprocessor triac array driver, II-410

optocoupler, V-407

interface circuits, V-406-407

optoisolator

interface circuits, V-406-407

relay circuit, IV-475

paper tape reader, II-414

photoelectric light controller, IV-369

photoreceiver, optimized noise/response, V-405

phototransistors

amplifier, V-409

variable-sensitivity, V-409

power outage light, line-operated, III-415

probe, IV-369

proximity detector, V-405

pyrometer, I-654

receivers, I-364, II-418

50 kHz FM optical transmitter, II-418

light receiver, IV-367

optical or laser light, IV-367, IV-368

relays, III-412, III-417, III-418

dc solid-state, open/closed, III-412

safety-circuit switch, V-409

Schmitt trigger, I-362

sensor, ambient light ignoring, III-413

sensor-to-TTL, interface, III-314

source follower, photodiode, III-419

telephone ring detector, III-611

transmitter, I-363, I-367, IV-368

light transmitter, IV-368

triggering SCR series, III-411

TTL coupler, optical, III-416

zero-voltage switching

closed half-wave, III-412

solid-state, III-410

solid-state relay, III-416

optocouplers (*see* optical circuits, couplers)

optoisolators (*see* optical circuits, isolators)

OR gate, I-395

relay circuit, VI-316

organ, musical, I-415

preprogrammed single chip microcontroller for, I-600

stylus, I-420

oscillators, II-420-429, III-420-432, IV-370-377, V-410-421, VI-432-459

1 kHz, II-427

1.0 MHz, I-571

2 MHz, II-571

5-V, III-432

50 kHz, I-727

400 MHz, I-571

500 MHz, I-570

800 Hz, I-68

adjustable over 10:1 range, II-423

AF power oscillator, V-412

AM-modulated oscillator for wireless microphones, VI-450

astable, I-462, V-420, VI-437, VI-438, VI-442, VI-443

audio, I-245, III-315, III-427, IV-374, IV-375

audio-frequency generator, V-416-417

audio-test oscillator, V-420

basic designs, V-414

beat-frequency audio generator, IV-371

beat-frequency oscillator, VI-452

buffer circuits, IV-89

Butler oscillator, VI-452

aperiodic, I-196

common base, I-191

crystal, I-182

emitter follower, II-190-191, II-194

calibration oscillator, UJT, 100-kHz, VI-157

cassette bias, II-426

Clapp oscillator, VI-458

clock generator, I-615, III-85

CMOS, I-615, III-429, III-430

1 MHz to 4 MHz, I-199

crystal, I-187

code practice, I-15, I-20, I-22, II-428, III-431, IV-373, IV-375, IV-376, V-100-103, VI-409

Colpitts crystal oscillators, I-194, I-572, II-147, V-411, VI-160, VI-458

1-to-20 MHz, IV-123

frequency checker, IV-301

harmonic, I-189-190

two-frequency, IV-127

crystal (*see* crystal oscillators)
 Darlington transistor oscillator, VI-455
 double frequency output, I-314
 discrete sequence, III-421
 duty-cycle
 50-percent, III-426
 555 circuit, VI-446
 variable, III-422, VI-438
 emitter-coupled
 big loop, II-422
 RC, II-266
 exponential digitally controlled, I-728
 feedback, I-67
 flasher and oscillator
 high-drive, II-235
 low-frequency, II-234
 FM high frequency oscillator, VI-456
 FM-modulated oscillator, VI-449
 free-running, I-531
 square wave, I-615
 frequency doubled output from, II-425, II-596
 frequency switcher, V-418
 gate dip oscillator, VI-344, VI-346
 gated, I-728, V-413, V-419
 last-cycle completing, III-427
 Hall effect circuits, V-222
 Hartley, I-571, V-140, VI-453, VI-459
 hc-based, III-423
 HCU/HCT-based, III-426
 high-current, square-wave generator, III-585
 high-frequency, III-426
 crystal, I-175, II-148
 LC audio oscillator, V-411
 LF oscillator, V-413
 light-controlled, V-279
 load-switching, 100 mA, I-730
 local oscillator, double-balanced mixer, V-415
 loop oscillator eliminator, VI-385
 low-distortion, I-570
 low-duty-cycle pulse circuit, IV-439
 low-frequency oscillators, III-428
 crystal, I-184, II-146
 oscillator/flasher, II-234
 Pierce oscillator, III-133
 TTL oscillator, II-595
 low-noise crystal, II-145
 Miller, I-193
 MOSFET mixer/oscillator for AM receivers, V-412
 NE602 local oscillator, V-411
 neon flasher, two-state, III-200
 one-second, 1 kHz, II-423
 one-shot, voltage-controlled high-speed, II-266
 overtone oscillators, I-176, I-177, I-180, I-183, I-186, II-146, III-146
 50 MHz to 100 MHz, I-181
 100 MHz, IV-124
 crystal, I-176, I-180, II-146
 crystal switching, I-183
 fifth-overtone, I-182
 third-overtone oscillator, IV-123
 phase-locked, 20-MHz, IV-374
 phase-shift oscillator, VI-435
 Pierce oscillator, V-140
 1-MHz, III-134
 crystal, II-144
 harmonic, I-199, II-192
 JFET, I-198
 low-frequency, III-133
 quad tone oscillator, VI-434
 quadrature, I-729, III-428, VI-444
 square-wave generator, III-585
 quartz, III-136
 R/C, I-612
 reflection, crystal-controlled, III-136
 Reinartz oscillator, VI-450
 relaxation, IV-376
 SCR, III-430
 remote oscillator high-frequency VFO, VI-451
 resistance-controlled digital, II-426
 rf oscillators, I-550-551, I-572, V-528-532, VI-448-459
 6.5 MHz VFO, V-529
 5 MHz VFO, II-551
 ham band VFO, V-532
 NE602 circuit, V-531
 rf-genic, II-421
 shortwave pulsed-marker, V-532
 sidetone, rf-powered, I-24
 signal generator, V-530-531
 test oscillator, V-412
 transmitter and, 27 MHz and 49 MHz, I-680
 RLC, III-423
 sawtooth wave, modulator, III-373
 Schmitt trigger crystal, I-181
 sine-wave (*see* sine-wave oscillators)
 sine-wave/square wave, tunable, I-65, III-232, IV-512
 single op amp, I-529
 siren oscillator, V-567
 square-wave, I-613-614, II-597, II-616, IV-532, IV-533, V-569, VI-445
 0.5 Hz, I-616
 1 kHz, I-612
 astable multivibrator and, V-386
 start-stop oscillator pulse circuit, IV-438
 switch, oscillator-triggered, V-590, VI-606
 switching, 20 ns, I-729
 temperature-compensated, III-137
 crystal, I-187
 low-power 5v-driven, II-142
 temperature-stable, II-427
 third overtone, I-186, IV-123
 time base, crystal, III-133, IV-128
 timer, 500 timer, I-531
 tone-burst, decoder and, I-726
 transmitter and, 27 MHz and 49 MHz rf, I-680
 triangle-wave oscillator, V-205
 triangle/square wave, I-616, II-422
 TTL, I-179, I-613, IV-127, VI-437
 1 MHz to 10 MHz, I-178
 1 MHz to 20 MHz, IV-127
 crystal, TTL-compatible, I-179
 sine wave/square oscillator, IV-512
 television display using, II-372
 tube type crystal, I-192
 tunable frequency, II-425
 tunable single comparator, I-69
 tuned collector oscillator, VI-454, VI-459
 UHF oscillator, tunable, VI-456
 varactor tuned 10 MHz ceramic resonator, II-141
 variable frequency oscillator, VI-438, VI-442, VI-443, VI-449, VI-451, VI-455, VI-457
 variable oscillators, II-421
 audio, 20 Hz to 20 kHz, II-727
 four-decade, single control for, II-424
 sine-wave oscillator, super low-distortion, III-558
 wide range, I-730, II-429
 variable-duty cycle, III-422, V-419
 VHF crystal oscillator
 20-MHz, III-138
 50-MHz, III-140
 100-MHz, III-139
 VLF LC oscillator, VI-454
 voltage-controlled (VCO) (*see* voltage-controlled oscillators)
 warble oscillator, VI-582
 wide-frequency range, II-262
 wide-range, I-69, III-425
 variable, I-730, II-429
 Wien-bridge oscillators, I-62-63, I-66, I-70, II-566, III-429, III-558, IV-371, IV-377, IV-511, V-415, V-419, VI-439, VI-444
 CMOS chip in, II-568
 low-distortion, thermally stable, III-557
 low-voltage, III-432
 sine wave, I-66, I-70, II-566, IV-510, IV-513
 single-supply, III-558
 thermally stable, III-557
 three-decade, IV-510
 variable, III-424
 very-low-distortion, IV-513
 XOR-gate, III-429
 yelp, II-577
 oscilloscopes, II-430-433, III-433-439, V-422-426, VI-460-464
 analog multiplexer, single- to four-trace scope converter, II-431
 beam splitter, I-474
 calibrator, II-433, III-436
 converter, I-471
 CRO doubler, III-439
 delayed video trigger, VI-464
 differential amplifier, VI-463
 eight-channel voltage display, III-435
 extender, III-434
 FET dual-trace switch for, II-432
 four-trace oscilloscope adapter, IV-267
 monitor, I-474
 multiplexer, add-on, III-437
 preamplifier, III-437, V-423
 counter, III-438
 instrumentation amplifiers, IV-230-231
 sampling rate phase lock, VI-462
 scope voltage cursor adapter, VI-461
 sensitivity amplifier, III-436
 spectrum analyzer adapter, V-424
 timebase generator, V-425
 trigger selector for timebase, V-425
 triggered sweep, III-438
 variable-gain amp, V-426
 voltage-level dual readout, IV-108
 outband descrambler, II-164
 out-of-bounds pulse-width detector, III-158
 outlet tester, V-318
 output limiter, III-322

output-gating circuit,
 photomultiplier, II-516
 output-stage booster, III-452
 output-to-current converter, VI-155
 over/under temperature monitor,
 dual output, II-646
 overload indicator, V-478
 overload protector, speaker, II-16
 overspeed indicator, I-108
 overtone oscillators, I-176, I-177, I-180, I-183, I-186, II-146, III-146
 50 MHz to 100 MHz, I-181
 100 MHz, IV-124
 crystal, I-176, I-180, II-146
 crystal switching, I-183
 fifth-overtone, I-182
 third-overtone oscillator, IV-123
 overvoltage protection, I-150, I-517, II-96, II-107, II-496, III-513, III-762, IV-389, V-480
 comparator to detect, II-107
 monitor for, III-762
 protection circuit, II-96, II-496, III-513
 undervoltage and, indicator, I-150, III-762

P

pager, pocket-size, III-288
 PAL/NTSC decoder, RGB input, III-717
 palette, video, III-720
 paring circuit, two-channel, I-57
 paper-sheet discriminator, copying machines, III-339
 paper-tape reader, II-414
 parallel connections, telephone, III-611
 party-line intercom, II-303
 password protection circuit, PCs, V-109, VI-135
 pattern generator/polar-to-rectangular converter for radio direction, V-288
 PCB continuity tester, II-342, II-535
 peak detectors, II-174, II-175, II-434-436, III-771, IV-138, IV-143
 analog, with digital hold, III-153
 closed-loop, V-153
 decibel peak meter, III-348
 digital, III-160
 high-bandwidth, III-161
 high-frequency peak, II-175
 high-speed peak, I-232, VI-175
 LED design, peak meter, III-333
 level detector, I-402
 low-drift, III-156, V-155, VI-183
 negative, I-225, I-234, V-154, VI-179, VI-183
 op amp, IV-145
 open-loop, V-153
 positive, I-225, I-235, II-435, III-169, VI-179, VI-183
 true rms, I-228
 ultra-low-drift peak, I-227
 voltage, precision, I-226
 wide-bandwidth, III-162
 wide-range, III-152
 peak program detector, III-771
 peak converter, precision ac/dc, II-127
 peak/hold circuit, VI-391
 people-detector, infrared-activated, IV-225
 percentage-deviation ratio computer, VI-326

period counter, 100 MHz, frequency and, II-136
 period-to-voltage converter, IV-115
 pest-repeller, ultrasonic, III-639, III-706, III-707, IV-605-606, V-427-428
 pH meters/probe, I-399, III-501, VI-523
 phase detection/manipulation circuits
 detectors, I-406, I-476, II-344, II-439, II-441, II-442, III-440-442, IV-127
 10-bit accuracy, II-176
 digital VOM, IV-277
 lock detector, VI-176-177
 phase-difference detector, 0- to 180-degree, II-344
 phase selector/sync rectifier/balanced modulator, III-441
 sequencers, phase sequence, I-476, II-437-442, III-441
 rc circuit, phase sequence reversal detection, II-438
 reversal, rc circuit to detect, II-438
 three-phase tester, II-440
 shifters, phase shifters, IV-647, V-429-431
 0-180 degree, I-477
 0-360 degree, I-477
 eight-output, V-431
 single-transistor design, I-476
 splitter, III-582, V-430
 long-tail pair, V-430
 phase-locked loop, V-347
 infrared laser light receiver, VI-294
 lock detector, VI-176-177
 tracker, three-phase square wave generator, II-598
 phasor gun, I-606, IV-523
 phonograph-related circuits (see stereo/phonograph circuits)
 photo-conductive detector amplifier, four quadrant, I-359
 photo memory switch for ac power control, I-363
 photo stop action, I-481
 photodiode/photocell circuits
 ac power switch, III-319
 alarm system, I-13, II-4
 amplifiers, I-361, II-324, III-19, III-672, VI-301, VI-302
 battery charger, solar, II-71, V-327
 comparator, precision, I-360
 controller, IV-369
 current-to-voltage converter, II-128
 flasher, photocell-controlled, II-232
 integrator, photocurrent, II-326
 level detector, precision, I-365
 light controller, IV-369
 log converter/transmitter, VI-312
 monostable photocell, self-adjust trigger, II-329
 output-gating circuit,
 photomultiplier, II-516
 PIN, thermally stabilized signal conditioner with, II-330
 PIN-to-frequency converters, III-120
 preamplifier for IR photodiode, V-226
 sensor amplifier, II-324
 smoke alarm/detectors, I-595, I-596
 solar power supply, VI-311, VI-312
 source follower, III-419
 sun tracker, VI-299, VI-312

switches, II-321, II-326, III-318, III-319
 photoelectric sensor, V-277
 photography-related circuits, II-443-449, III-443-449, IV-378-382, V-432-438, VI-466-468
 auto-advance projector, II-444
 camera alarm trigger, III-444
 camera trip circuit, IV-381
 charger for photoflash capacitor, VI-466
 contrast meter, II-447
 darkroom enlarger timer, III-445
 darkroom timer, V-436
 electronic flash trigger, II-448, III-449
 enlarger exposure meter, V-438
 enlarger light meter, V-434-435
 enlarger timer, II-446
 exposure meter, I-484, V-438
 flash meter, III-446
 flash slave driver, I-483
 flash slave unit, V-433
 flash triggers
 electronic, II-448
 remote, I-484
 sound-triggered, II-449
 time delay, V-433
 xenon flash, III-447
 light meter, VI-308, VI-350
 light meter, enlargers, V-434-435
 photo-event timer, IV-379
 photoflash, electronic, III-449
 picture fixer/inverter, III-722
 shutter speed tester, II-445
 slave-flash unit trigger, IV-380, IV-382, V-433, V-436
 slide projector auto advance, IV-381
 slide-show timer, III-444, III-448
 slide stopper for projector, VI-467
 sound trigger for flash unit, II-449, IV-382
 strobe, V-435, V-436, V-437, VI-468
 time-delay flash trigger, IV-380, V-433
 photomultipliers
 high-voltage power supply, V-444, V-445
 phototransistor, V-279
 amplifier, V-409
 variable-sensitivity, V-409
 timer, I-485
 xenon flash trigger, slave, III-447
 picoammeters, I-202, II-154, III-338
 circuit for, II-157
 guarded input circuit, II-156
 picture fixer/inverter, III-722
 Pierce oscillators, V-140
 1-MHz, III-134
 crystal, I-195, II-144
 harmonic, I-199, II-192
 JFET, I-198
 low-frequency, III-133
 piezoelectric circuits, V-439-441, VI-469-470
 alarm, I-12, V-10
 buffer circuit, VI-470
 drivers, V-440, VI-470
 555 oscillator, V-441
 CMOS, V-440
 micropositioner, V-440
 temperature controller, fan-based, III-627
 PIN diodes
 filter selection circuit, VI-213
 test circuit, VI-353

PIN photodiode-to-frequency converters, III-120
 pink noise generator, I-468
 pipe detector, metal pipes, V-323
 plant-watering accessories, I-443, II-245, II-248
 playback amplifier, tape, I-77
 PLL/BC receiver, II-526
 pocket pager, III-288
 polar-to-rectangular converter/pattern generator, radio direction finder, V-288
 polarity converter, I-166
 polarity gain adjustment, op amp circuit, V-400
 polarity indicator, V-231
 polarity-protection relay, IV-427
 polarity protector, VI-526
 polarity-reversing amplifiers, low-power, III-16
 poller, analog-to-digital converters, V-28
 polynomial generator, V-287
 position indicator/controller, tape recorder, II-615
 positive input/negative output charge pump, III-360
 positive regulator, NPN/PNP boost, III-475
 potentiometers, digital control, V-158
 power amplifiers, II-450-459, III-450-456
 2- to 6-watt audio amplifier with preamp, II-451
 10 W, I-76
 12 W low-distortion, I-76
 25 W, II-452
 90 W, safe area protection, II-459
 AM radio, I-77
 audio, II-451, III-454, IV-28-33
 20-W, III-456
 50-W, III-451
 6-W, with preamp, III-454
 booster, II-455
 bridge audio, I-81
 bull horn, II-453
 class-D, III-453
 GaAsFET with single supply, II-10
 hybrid, III-455
 inverting, I-79
 low-distortion, 12 W, I-76
 low-power audio, II-454
 noninverting, I-79
 op amp/audio amp, high-slew rate, I-82
 output-stage booster, III-452
 portable, III-452
 rear speaker ambience amplifier, II-458
 rf power amplifier
 1296-MHz solid state, III-542
 5W, II-542
 600 W, I-559
 switching, I-33
 two-meter 10 W, I-562
 walkman amplifier, II-456
 power line circuits, VI-471-475
 ac power controller, VI-472-473
 ac power line monitor, VI-473
 low voltage power controller, VI-475
 modem for computer control, VI-474
 power meter, VI-333
 power supplies (see also voltage indicators/meters), II-460-486, III-464, V-448-472, VI-476-498, VI-506-519
 0- to 30-V supply, VI-518
 0- to 5-V supply, VI-516
 +1.5-V supply for ZN416E circuits, V-469
 3.3-V from 5-V logic supplies, VI-492
 +5 V supply, V-471, VI-481, VI-491, VI-495
 5-A constant-voltage supply, VI-498
 ± 5 to ± 35 V tracking, V-469
 0- to 12-V, V-1 A variable, V-460
 9-V supply, VI-485, VI-495
 10-MHz frequency standard, VI-335
 12-V supply, VI-492, VI-493
 12-Vdc regulated supply, VI-497
 13.8-Vdc, V-2 A regulated, V-459
 ±15-V supply, VI-513
 20-V adjustable, V-461
 5V power supply with momentary backup, II-464
 5V, 0.5A power supply I-491
 8- from 5-V regulator, V-469
 2,000 V low-current supply, IV-636-637
 AA cells, +5 V/+3.6 V, V-452
 ac outlet tester, V-318
 ac power controller, VI-472-473
 ac power line monitor, VI-473
 ac wiring locator, V-317
 ac-watts calculator, V-304
 adjustable current limit and output voltage, I-505
 adjustable 20-V, V-461
 adjustable supply, VI-517
 amateur radio amplifier, 1.2-kW 144-MHz, VI-18
 amplifiers, audio,
 dual power supply, V-465
 subwoofer power supply, V-464
 antique radio dc filament supply, V-470
 arc lamp, 25W, II-476
 arc-jet, starting circuit, III-479
 automotive-accessory power controller, V-70
 automotive audio system supply, VI-103, VI-483
 automotive power supply, VI-513
 balance indicator, III-494
 battery (see battery-related circuits)
 battery charger and, 14V, 4A, II-73
 battery power pack, I-509
 bench top, II-472
 benchtop, dual output, I-505
 bias regulator, VI-519
 bipolar
 battery instruments, II-475
 tracking double-output, V-449
 booster, I-28, I-33, V-349
 buck regulator, add 12-V output to 5-V, V-472
 CCEFL supply with variable contrast, VI-510
 charge pool, III-469
 configurable, V-455
 connections-monitor, ac lines, III-510
 consumption limiters, III-572
 consumption monitor, V-290
 controllers, IV-383-389, V-111-115
 ac switches, IV-387, V-112, V-115
 ac voltage control, V-114
 automotive-accessory power, V-70
 bang-bang controllers, IV-389
 burst-type control, III-362
 current-loop control, SCR design, IV-387
 dual-control ac switch, V-115
 high-side switches, 5 V supplies, IV-384, IV-385
 monitor, SCR design, IV-385
 MOSFET switch, IV-386
 overvoltage protection, I-150, I-517, II-96, II-107, II-496, III-513, III-762, IV-389
 power controller, universal design, IV-388
 power-down circuit, V-114
 pushbutton switch, IV-388
 three-phase, power factor control, II-388
 converter
 225-W 15-V output, VI-148-149
 inductorless, V-456
 current limiter, V-146, V-358, V-458
 current regulator, 100-mA, VI-478, VI-489
 current sources, I-205, I-697, V-141-143, VI-161-163
 0-to-200-nA, IV-327
 bilateral, III-469, I-694-695, V-143
 bipolar sources, I-695, I-697
 constant, I-697, III-472
 fixed power supplies, IV-405, IV-406
 low-current source, IV-399
 low-resistance, V-142
 negative, V-143
 offset-adjusting, V-145
 positive, V-142
 precision, I-205, I-206
 regulator, variable power supply, III-490
 variable power supplies, voltage-programmable, IV-420
 voltage-controlled, grounded source/load, III-468
 dc-to-dc SMPS variable 18V to 30 V out at 0.2A, II-480
 dc power circuit, NE602-based, V-358
 dc power source, VI-511
 dc supply, VI-480, VI-481, VI-496
 delay circuit, V-148
 differential voltage-to-current converter, VI-153
 disconnect, low-voltage, II-97
 dual polarity, I-497
 dual power supply, amplifiers, V-465
 ELF monitor, VI-336
 experimenter's power source, VI-507, VI-511
 failure/outage alarms/monitors, I-581-582, II-107, II-486, II-175, II-491-497, III-493-495, III-511, IV-422-427
 backup supply, drop-in main-activated, IV-424
 balance monitor, III-494
 booster/buffer, boosts reference current, IV-425
 circuit breaker, trip circuit, IV-423
 connections monitor, ac lines, III-510
 fault monitor, single-supply, III-495
 memory protector/supply monitor, IV-425
 polarity-protection relay, IV-427

- power supplies *continued*
- SCR design, IV-385
 - test load, constant-current, IV-424
 - triac for ac-voltage control, IV-426
 - tube amplifier, high-voltage isolation, IV-426
 - voltage sensor, IV-423
 - fixed power supplies (*see* fixed power supplies)
 - flash memory programming supply, +12 volt, VI-138
 - flyback power supply for radon detector, VI-531
 - foldback current limiter, VI-477
 - frequency, power/frequency meter, II-250
 - fuses, V-477, V-478
 - gain, power-gain test circuit, 60 MHz, I-489
 - general-purpose, III-465
 - glitch detector, II-107, VI-178
 - grid leak detector, VI-179
 - high-voltage (*see* high-voltage power supplies)
 - IC regulator protector, VI-483
 - increasing zener diode power rating, II-485
 - inductorless converter, V-456
 - inverters, III-298, V-457
 - 12 VDC-to-117 VAC at 60 Hz, III-294
 - medium, III-296
 - MOSFET, III-295
 - isolated feedback, III-460
 - isolation transformer, V-349, V-470
 - laptop-computer supply, V-463
 - laser power supplies, IV-636, V-251, V-252, V-253, V-254, VI-291, VI-295
 - level sensor, voltage level, III-770
 - logic regulator, 5-V, with electronic shutdown, VI-496
 - loss detector, II-175
 - low-ripple, I-500
 - low-voltage power controller, VI-475
 - LTC, single supply, V-454
 - meters, power meters, I-489
 - audio, I-488
 - frequency and, II-250
 - rf, I-16
 - SWR, I-16
 - memory save on power-down, II-486, IV-425
 - micropower bandgap reference, II-470
 - microprocessor power supply
 - watchdog, II-494
 - modern, power-line, III-82
 - monitors, II-491-497, III-493-495, IV-422-427
 - backup supply, drop-in main-activated, IV-424
 - balance monitor, III-494
 - booster/buffer, boosts reference current, IV-425
 - circuit breaker, trip circuit, IV-423
 - connections monitor, ac lines, III-510
 - fault monitor, single-supply, III-495
 - memory protector/supply monitor, IV-425
 - polarity-protection relay, IV-427
 - SCR design, IV-385
 - test load, constant-current, IV-424
 - triac for ac-voltage control, IV-426
 - tube amplifier, high-voltage isolation, IV-426
 - voltage monitors (*see* voltage indicators/meters)
 - multivoltage output, VI-506-513
 - multivoltage supply, V-458
 - NE602 power supply options, VI-484
 - negative supply, V-457
 - neon lamp driver, V-5- to 15-V supplies, V-459
 - noise detector for ac circuits, VI-184
 - notebook computer triple-output supply, VI-512
 - outage light, line-operated, III-415
 - overload indicator, V-478
 - overvoltage protection, I-150, I-517, II-96, II-107, II-496, III-513, III-782, IV-389, V-480
 - polarity protector, VI-526
 - power saver for computer monitors, VI-139
 - power-down circuit, V-114
 - programmable, III-467
 - protection circuits, I-515, I-518, II-98, II-107, II-474, II-486, II-496, II-497, III-511, IV-425, IV-427
 - push-pull, 400V/60W, II-473
 - quad power supply, VI-508
 - rectifiers, V-464, V-466, VI-490
 - reference, I-694, VI-496
 - regulated power supplies
 - 8-amp, for mobile equipment operation, II-461
 - 10 A, current and thermal protection, II-474
 - 12-14 V, 3A, II-480
 - 13.8-Vdc, V-2 A, V-459
 - +15V I-A, III-462
 - 15V I-A, III-463
 - split, I-492
 - regulator loss cutter, V-467
 - regulators (*see* voltage regulators)
 - reset circuit, II-366
 - short-circuit protection circuit, VI-526
 - short-tester, V-313, V-315
 - solar power supply, VI-311, VI-312
 - solenoid driver, VI-202
 - split, I-512
 - stand-by, non-volatile CMOS RAMs, II-477
 - subwoofer amplifier power supply, V-464
 - sun tracker power supply, VI-312
 - supply-voltage monitor, V-320
 - switching power supplies, II-466, II-470, III-458, V-453, V-461, V-462, V-468, VI-479
 - 50-W off-line, III-473
 - 500 kHz switching inverter for 12V, II-474
 - complementary ac switch, I-379
 - control circuits, VI-494
 - power-switching circuit, II-466
 - regulator, VI-484
 - SCR, for color TV receiver, VI-487
 - variable, 100-kHz multiple-output, III-488
 - synchronous stepdown switching regulator, V-468
 - telecom converter -48 to +5 V at 1 A, V-472
 - teleprinter loop supply, VI-497
 - three-rail, III-466
 - tracking power supply, VI-485
 - transceiver supply for lab source, VI-517
 - transformer tester, VI-354
 - undervoltage detector/monitor, III-762, IV-138
 - uninterruptible, II-462, III-477, V-471
 - universal laboratory supply, V-450-451
 - vacuum-tube amplifier supply, VI-87
 - variable power supplies, III-487-492, IV-414-421, VI-514-519
 - VFO supply, VI-511
 - 0- to 12-V, V-1 A, V-460
 - current source, voltage-programmable, IV-420
 - dc supplies, IV-418
 - dual universal supply, 0-to-50 V, 5 A, IV-416-417
 - switch-selected fixed-voltage supply, IV-419
 - switching regulator, low-power, III-490
 - switching, 100-kHz multiple-output, III-488
 - tracking preregulator, III-492
 - transformerless supply, IV-420
 - universal 3-30V, III-489
 - voltage regulators for variable supplies, III-490, III-492, IV-421
 - vocal stripper power supply, VI-373
 - voltage doubler, V-460
 - voltage probes, V-474
 - voltage/current regulator, V-455
 - voltage regulators (*see* voltage regulators)
 - voltage sensor, power supplies, IV-423
 - voltage-level, III-770
 - voltage sources
 - millivolt, zenerless, I-696
 - programmable, I-694
 - voltage splitter, III-738
 - preamplifiers, I-41, V-26
 - AGC audio preamp, VI-2
 - amateur TV, mast-mounted, VI-37
 - antenna preamp
 - HF broadband, V-36
 - loop antenna, V-38
 - VLF 60-kHz, V-33
 - wideband, V-35
 - 6 meter, 20 dB gain and low-NF, II-543
 - 1000x, low-noise design, IV-37
 - audio preamplifiers, II-45
 - 2- to 6-watt, II-451
 - 6-W and, III-454
 - audio-to-UHF preamp, V-24
 - balanced microphone preamp, VI-77
 - bias supply, IV-318
 - dual audio signal amplifiers, V-58
 - electret microphone preamp, V-21
 - equalized, for magnetic phono cartridges, III-671
 - FET phono cartridge, VI-79
 - frequency counter/divider, III-128, V-24
 - GAsFET, rf amplifiers, V-516
 - general purpose, I-84, IV-42
 - handtalkies, two-meter, I-19
 - HF, rf amplifiers, V-515

IF, 30 MHz, IV-460
 IR photodiode preamp, V-226
 impedance-matching, IV-37
 instrumentation amplifier, IV-230-231
 JFET, V-22
 light-beam activated alarm circuit, V-13
 LM382 phono, I-91
 low-noise, I-88, I-561, IV-41
 magnetic, I-89, I-91, III-37, III-673, IV-35, IV-36
 medical instrument, II-349
 microphone preamplifiers, II-45, IV-37, IV-42, VI-56
 dynamic microphones, VI-76, VI-79
 low-impedance, IV-41
 tone control for, II-687
 transformerless, unbalanced input, I-88
 transformerless, unbalanced input, I-88
 microwave preamplifiers, IV-316-319
 mixers, I-58
 NAB preamplifiers
 tape playback, professional, III-38
 record, III-673
 two-pole, III-673
 oscilloscope preamplifiers, III-437, III-438, IV-230-231, V-423
 oscilloscope/counter, III-438
 power amplifier with preamp, II-451, III-454
 read-head, automotive circuits, III-44
 receiver interface, V-243
 receiver preamp, VI-553
 rf amplifiers, V-526, V-527
 RIAA, III-38, VI-80
 RIAA/NAB compensation, I-92
 saw-filter impedance-matching preamp, VI-222
 stereo/phonograph preamps, I-91, II-43, II-45, V-584
 low-noise, IV-36
 magnetic, I-91, III-37, III-673, IV-35, IV-36
 tone control, V-581
 tape, I-90
 thermocouple instrumentation amplifier, III-283
 tone control preamplifiers, I-675
 high-level, II-688
 IC, I-673, III-657
 mixer, I-58
 transistor RIAA for magnetic phone cartridges, VI-76
 transmit/receive sequencer, V-348
 UHF-TV, III-546
 ultra-low-leakage, I-38, II-7
 VHF, I-560
 VHF/UHF, rf amplifiers, V-515
 video, V-660
 preregulators
 high-voltage power supplies, III-480
 tracking, III-492
 prescalers
 data circuits, low-frequency, IV-132
 probe, amplifying, 650 MHz, II-502
 preselectors, rf amplifiers, IV-483, IV-485, IV-488
 pressure gauge, V-314
 printer-error alarm, computer circuits, IV-106
 printers
 port, VI-134-135
 printer-error alarm, IV-106
 printer sentry, computer circuits, V-107-108
 two-sheets in printer detector, IV-136
 probes (see also measurement/test circuits), II-498-504, III-496-503, IV-428-434, V-473-474, VI-520-524
 100 K megaohm dc, I-524
 ac hot wire, I-581
 audible TTL, I-524
 audio-rf signal tracer, I-527
 capacitance buffer
 low-input, III-498
 stabilized low-input, III-502
 clamp-on-current compensator, II-501
 CMOS logic, I-523
 current probe amplifier, VI-521
 FET, III-501
 frequency probe, 8-digit, 100-MHz, VI-524
 general purpose rf detector, II-500
 ground-noise, battery-powered, III-500
 logic probes, I-520, I-525, I-526, IV-430-431, IV-434, VI-522, VI-523
 CMOS, I-523, I-526, III-499
 digital, III-497
 four-way operation, IV-432
 memory-tester, installed, I-525
 single-IC design, IV-433
 three-in-one test set: probe, signal tracer, injector, IV-429
 microvolt, II-499
 optical light probe, IV-369
 pH, I-399, III-501, VI-523
 prescaler, 650 MHz amplifying, II-502
 rf, I-523, III-498, III-502, IV-433, VI-522
 single injector-tracer, II-500
 test, 4-220V, III-499
 three-in-one test set: logic probe, signal tracer, injector, IV-429
 tone, digital IC testing, II-504
 universal test probe, IV-431
 process control interface, I-30, V-242, VI-355
 processor, CW signal, I-18
 product detector, I-223
 programmable amplifiers, II-334, III-504-508
 differential-input, programmable gain, III-507
 inverting, programmable-gain, III-505
 noninverting, programmable-gain, III-505
 precision, digital control/programming, III-506
 programmable-gain, selectable input, I-32
 variable-gain, wide-range digital control, III-506
 projectors (see photography-related circuits)
 protection circuits, II-95-99, III-509-513, V-475-483, VI-525-526
 12 ns circuit breaker, II-97
 automatic power down, II-98
 circuit breakers
 ac, III-512
 electronic, high-speed, II-96
 compressor protector, IV-351
 crowbars, electronic, II-99, III-510
 ear protector, V-482
 fuse, electronic, V-477
 halogen lamp protector, V-271
 heater protector, servo-sensed, III-624
 IC regulator protector, VI-483
 line protectors, computer I/O, 3 μ P, IV-101
 line dropout detector, II-98
 line-voltage monitor, III-511
 loudspeaker protector, V-483
 low-voltage power disconnecter, II-97
 modem protector, V-479
 modem/fax protector for two computers, V-482
 optical safety-circuit switch, V-409
 overload indicator, V-478
 overvoltage protection, I-150, I-517, II-96, II-107, II-496, III-513, III-762, IV-389, V-480
 password protection for PCs, V-109
 polarity protector, VI-526
 polarity-protection relay for power supplies, IV-427
 power-down, II-98
 power-failure alarm, III-511
 power-line connections monitor, ac, III-510
 power supply, II-497, I-518
 relay fuse, V-478
 reset-protection for computers, IV-100
 reverse polarity protection for battery pack, VI-30
 safety circuit, V-477, V-481, V-483, V-589
 short-circuit protection circuit, VI-526
 short-tester, V-313, V-315
 shutdown circuits, V-537-538
 speaker protector, V-476, V-479
 proximity sensors (see motion/proximity detectors)
 pseudorandom sequencer, III-301, V-351
 pulse circuits, IV-435-440
 amplitude discriminator, III-356
 coincidence detector, II-178
 converters
 height-to-width, III-119
 pulse train-to-sinusoid converters, III-122
 counter, ring counter, low-power, IV-437
 delay, dual-edge trigger, III-147
 detectors
 fast pulse, V-154
 missing pulse, V-152
 out-of-bounds pulse width, III-158
 sequence detector, II-172
 divider, non-integer programmable, II-511, III-226
 extractor, square-wave, III-584
 generators, pulse generators, II-508-511, V-487-492, VI-699
 2-ohm, III-231
 300-V, III-521
 555-circuit, IV-439
 add-on, V-488
 astable multivibrator, II-510
 basic, V-488
 clock, 60 Hz, II-102

- pulse circuits *continued*
 - CMOS short-pulse, III-523
 - delayed-pulse, II-509, IV-440, V-492
 - divider, programmable, II-511, III-226
 - EEPROM, 5V-powered, III-99
 - free running, IV-438
 - interrupting pulse-generation, I-357
 - logic, III-520, V-489
 - logic troubleshooting applications, IV-436
 - one-shot, V-490-491
 - programmable, I-529
 - sawtooth-wave generator and, III-241, V-491
 - single, II-175
 - train, pulse train, IV-202
 - transistorized, IV-437
 - two-phase pulse, I-532
 - unijunction transistor design, I-530
 - variable duty cycle, V-492
 - very low-duty-cycle, III-521
 - voltage-controller and, III-524
 - wide-ranging, III-522
 - missing-pulse detector, V-152
 - modulators
 - pulse-position, III-375
 - pulse-width (PWM), III-376, IV-326, VI-400-401, VI-402
 - brightness controller, III-307
 - control, microprocessor selected, II-116
 - motor speed control, II-376, III-389
 - multiplier circuit, II-264, III-214
 - out-of-bounds detector, III-158
 - proportional-controller circuit, II-21
 - servo amplifier, III-379
 - signal generator, VI-698
 - speed control/energy-recovering brake, III-380
 - very short, measurement circuit, III-336
 - oscillators
 - fast, low-duty-cycle, IV-439
 - start-stop, stable design, IV-438
 - pulse-position modulator, III-375
 - stretchers, IV-440
 - negative pulse stretcher, IV-436
 - positive pulse stretcher, IV-438
 - supply circuit, high-voltage power supplies, IV-412
 - width, out-of-bounds pulse width detector, III-158
 - pulse-dialing telephone, III-610
 - pulse-width-to-voltage converters, III-117
 - pulse-width modulators (PWM), III-376, IV-326
 - brightness controller, III-307
 - control, microprocessor selected, II-116
 - motor speed control, II-376, III-389
 - multiplier circuit, II-264, III-214
 - out-of-bounds detector, III-158
 - proportional-controller circuit, II-21
 - servo amplifier, III-379
 - speed control/energy-recovering brake, III-380
 - very short, measurement circuit, III-336
 - pulse/tonc dialer, single-chip, III-603
 - pulsers, laser diode, III-311
 - pump circuits
 - controller, single chip, II-247
 - positive input/negative output charge, I-418
 - push switch, on/off, electronic, II-359
 - push-pull amplifier, Darlington, V-22
 - push-pull power supply, 400V/60W, II-473
 - pushbutton power control switch, IV-388
 - PUT circuits
 - battery chargers, III-54
 - long-duration timer, II-675
 - pyrometer, I-654, VI-640
- Q**
- Q-multipliers
 - audio, II-20
 - transistorized, I-566
 - QRP circuits
 - 18-, V-21-, V-24-MHz, V-644-645, CW transmitter, III-690
 - sidetone generator/code practice oscillators, V-102
 - SWR bridge, III-336
 - transmitters, V-10-M DSB with VFO, V-638-639
 - quad op amp, simultaneous waveform generator using, II-259
 - quadrature oscillators, III-428, VI-444
 - square-wave generator, III-585
 - quiz master game, V-210
- R**
- race-car motor/crash sound generator, III-578
 - radar detectors, II-518-520, IV-441-442, VI-527-529
 - one-chip, II-519
 - radar guns, VI-528, VI-529
 - radiation detectors, II-512-517, VI-530-533
 - alarm, II-4
 - Geiger counter, VI-531
 - ion detector, VI-533
 - micropower, II-513
 - monitor, wideband, I-535
 - photomultiplier output-gating circuit, II-516
 - pocket-sized Geiger counter, II-514
 - radon detector, VI-531, VI-532-533
 - radio/rf circuits
 - aircraft receiver, VI-118- to 136-MHz, VI-542
 - AM and shortwave, ac/dc vacuum-tube design, VI-536-537
 - AM radio
 - broadcast trap, SW receivers, VI-214
 - car-radio to short-wave radio converter, IV-500
 - demodulator, II-160
 - detector, 455-kHz, VI-184
 - power amplifier, I-77
 - receivers, II-525, III-81, III-529, III-535, IV-455, V-496, V-497, V-502, VI-535, VI-547, VI-550, VI-552
 - AM/FM radio
 - clock radio, I-543
 - squelch circuit, II-547, III-1
 - amateur radio, III-260, III-534, III-675
 - transceiver relay interface, V-243
 - VFO, V-532
 - voice identifier, V-550
 - amplifiers (*see* rf amplifiers)
 - antique radio dc filament power supply, V-470
 - antenna, remote tuned active HF, VI-62
 - attenuator, IV-322
 - automotive receiver, II-525
 - beat-frequency oscillator, VI-452
 - bridge, 50-MHz bridge circuit, V-303
 - broadcast, II-546, III-264, IV-271
 - broadband antenna, miniature (3 to 30 MHz), VI-63
 - burst generators, portable, III-73
 - calibrator, V-298
 - carrier-current circuits, III-78-82, IV-91-93
 - AM receiver, III-81
 - audio transmitter, III-79
 - data receiver, IV-93
 - data transmitter, IV-92
 - FM receiver, III-80
 - intercom, I-146
 - power-line modem, III-82
 - receivers, I-141, I-143, I-145, I-146
 - relay, I-575, IV-461
 - remote control, I-146
 - transmitters, I-144
 - IC, I-145
 - on/off 200 kHz line, I-142
 - clock, I-542
 - converters, IV-494-501
 - ATV receiver/converter, 420 MHz, low-noise, IV-496, IV-497
 - HF receiver, VI-147
 - radio beacon converter, IV-495
 - receiver frequency-converter stage, IV-499
 - SW converter for AM car radio, IV-500
 - two-meter, IV-498
 - up-converter, TVRO subcarrier reception, IV-501
 - VLF converter, IV-497, V-121
 - WWV converter, VI-147
 - WWV for car radio, V-119
 - WWV-to-SW converter, IV-499
 - receiving converter, 220 MHz, IV-500
 - crystal radio detector, VI-182
 - crystal radio receiver, VI-549, VI-557
 - current readout, I-22
 - CW-related circuits
 - filter, II-219, VI-405
 - identifier, VI-408
 - keying circuits, IV-244
 - offset indicator, IV-213
 - SSB/CW product detector, IV-139
 - SSB/CW receiver, V-499
 - transceiver, 5 W, 80-meter, IV-602
 - transmitters, III-678, III-684, III-686, III-690, IV-601, VI-664
 - detector, II-500, IV-433
 - direction finder, radio signals, IV-148-149
 - polar-to-rectangle converter/pattern generator, V-288
 - double-sideband suppressed-carrier modulator, III-377
 - rf, II-366
 - FM radio, I-545
 - 5 V, I-233
 - 12 V, I-233
 - automobile radio diversity antenna, VI-64-65

bug, VI-662
 clock radio, AM/FM, I-543
 demodulators, I-544, II-159, II-161
 high frequency oscillator, VI-456
 IF amplifier with quadrature detector, TV sound IF, I-690
 generators, low-frequency, III-228
 receivers, I-338, I-361, III-80, III-530, III-532, V-495
 scanner noise squelch, VI-579
 snooper, III-680
 speakers, remote, carrier-current system, I-140
 squelch circuit for AM, I-547
 stereo demodulation system, I-544, II-159
 stereo transmitter, VI-662
 FM/AM receiver, VI-541
 transmitters, I-361, I-367, I-681, II-417, III-687-688, IV-228
 tuner, I-231, III-529
 wireless microphone, III-682, III-685, III-691
 genie, II-421
 input circuits, NE602, V-500
 IF filter for shortwave receiver, VI-212
 line sampler, VI-30
 linearized RF detector, VI-177
 measurement/test circuits, IV-297-303, V-412
 modulators, I-436, II-369, III-372, III-374
 Morse code circuits, VI-404-409
 oscillators, I-550-551, I-572, V-528-532, VI-448-459
 5 MHz VFO, II-551
 6.5 MHz VFO, V-529
 ham band VFO, V-529
 NE602 circuit, V-531
 transmitter and, 27 MHz and 49 MHz, I-680
 rf-genie, II-421
 shortwave pulsed-marker, V-532
 sidetone, rf-powered, I-24
 signal generator, V-530-531
 output indicator, IV-299
 NB FM audio amplifier, VI-74
 power meters, I-16, I-24, III-332, III-592
 portable-radio 3 V fixed power supplies, IV-397
 probe, I-523, III-498, III-502, VI-522
 radio beacon converter, IV-495
 radio-commercial zapper, V-334-335
 RC receiver relay interface, VI-551
 receivers, VI-551
 AM radio, II-525, III-81, III-529, III-535, IV-455, V-496, V-497, V-502
 automotive receiver, II-525
 carrier-current, I-141, I-143, I-145, I-146
 CW/SSB receiver, V-80- and 40-meter, V-499
 data receiver, IV-93
 FM radio, I-338, I-361, III-80, III-529, III-530, III-532, V-495
 old-time design, IV-453
 radio-control receiver/decoder, I-574
 reflex radio receiver, IV-452
 regenerative receiver, VI-551, VI-554, VI-555
 short-wave receiver, IV-454
 signal-strength indicator, VI-260
 superheterodyne, V-503
 TRF radio receiver, IV-452
 VLF whistler, V-496
 RF power meter, VI-348
 scanner silencer circuit, VI-579
 scanners, VI-578-580
 series/shunt PIN-diode RF switch, VI-610
 shortwave transmissions
 converters, III-114, IV-500
 FET booster, I-561
 interference trap, VI-214
 receiver, IV-454, VI-540, VI-543, VI-544-545, VI-546, VI-556
 single-sideband (SSB)
 communications
 CW/SSB product detector, IV-139
 driver, low-distortion 1.6 to 30 MHz, II-538
 generators, IV-323
 transmitter, crystal-controlled
 LO for, II-142
 signal tracer probe, audio, I-527
 sniffer, II-210
 static detector, IV-276
 superheterodyne receivers, V-503, VI-553
 switch, low-cost, III-361
 tuned collector oscillator, for AM broadcast band, VI-454
 two-band radio receiver, VI-548
 UHF scanner active antenna, VI-67
 vacuum tube amplifier, VI-72-73, VI-87
 variometer-tuned radio receiver, VI-557
 VHF/UHF diode switch, IV-544
 VLF converter, V-121
 VLF whistler receiver, V-496
 voltmeter, I-405, III-766
 waveguides, VI-703-704
 WWV converter for car radio, V-119
 WWV receiver, VI-538-539, VI-558
 radio beacon converter, IV-495
 radio-control circuits (*see also* remote control devices)
 audio oscillator, II-567, III-555
 motor speed controller, I-576
 phase sequence reversal by, II-438
 oscillator, emitter-coupled, II-266
 receiver/decoder, I-574
 single-SCR design, II-361
 radioactivity (*see* radiation detectors)
 radon detector, VI-531, VI-532-533
 rain warning beeper, II-244, IV-189
 RAM, non-volatile CMOS, stand-by power supply, II-477
 ramp generators, I-540, II-521-523, III-525-527, IV-443-447
 555 based, V-203
 accurate, III-526
 integrator, initial condition reset, III-527
 linear, II-270
 variable reset level, II-267
 voltage-controlled, II-523
 ranging system, ultrasonic, III-697
 RC decade box, V-294-295
 RC receiver relay interface, VI-551
 reaction timer, IV-204
 read-head pre-amplifier, automotive circuits, III-44
 readback system, disc/tape phase modulated, I-89
 receivers, (*see also* transceivers; transmitters), II-524-528, III-528-535, IV-448-460, V-493-503, VI-534-558
 50 kHz FM optical transmitter, I-361
 acoustic-sound receiver, IV-311
 AGC system for CA3028 IF amplifier, IV-458
 aircraft receiver, 118- to 136-MHz, VI-542
 AM and shortwave, ac/dc vacuum-tube design, VI-536-537
 AM radio, II-525, III-81, III-529, III-535, IV-455, V-496, V-497, V-502, VI-535, VI-547, VI-550, VI-562
 mixer/oscillator for AM receivers, V-412
 analog, I-545
 ATV rf receiver/converter, 420 MHz, low-noise, IV-496, IV-497
 audio circuit, IV-31
 audio receiver, visible-light, V-261
 automotive radio, II-525
 automobile security system, VI-11
 baby-alert, carrier-current circuit, V-96
 bandswitching for receiver, VI-608
 carrier current, I-141, I-143, I-145, I-146
 carrier-operated relay (COR), IV-461
 CMOS line, I-546
 crystal radio receiver, VI-549, VI-557
 CW/SSB receiver, 80- and 40-meter, V-499
 data receiver/message demuxer, three-wire design, IV-130
 direct-conversion receiver
 7-MHz receiver, VI-153
 160-to-20 meters, V-494
 hum reducer, V-347
 NE602, V-498
 fiberoptic receivers
 10 MHz, II-205
 50-Mbps, III-181
 data receiver, VI-207
 digital, III-178
 high-sensitivity, 30nW, I-270
 low-cost, 100-M baud rate, III-180
 low-sensitivity, 300nW, I-271
 very high-sensitivity, low-speed 3nW, I-269
 FM radio, I-338, I-361, III-80, III-529, III-530, III-532, V-495
 light-beam, V-259
 FM/AM receiver, VI-541
 FSK data, III-533
 ham-band, III-534
 hum reducer, V-347
 IF amplifier/receivers, IV-459, IV-460
 infrared, I-342, II-292, III-274, IV-220-221, V-226, V-229, VI-268, VI-294
 audible-output, VI-271
 data-link, VI-265
 FM audio reception, VI-268
 headphones, V-227
 single-tone, VI-270
 wireless headphones, VI-269
 laser, IV-368, VI-292
 LED lightwave communications, VI-310

- receivers *continued*
- LF receiver, IV-451
 - line-type, III-532, III-534, V-497, VI-542, VI-552
 - MIDI receiver, V-392
 - modulated-light receiver, V-258
 - monitor for, II-526
 - optical receivers, I-364, II-418, IV-367, IV-368
 - photoreceiver, optimized response, V-405
 - PLL/BC, II-526
 - preamp for receiver, VI-553
 - preamp receiver interface, V-243
 - PPT control from receiver audio, VI-28
 - pulse-frequency modulated, IV-453
 - radio control, decoder and, I-574
 - radio (*see* radio/xf circuits, receivers)
 - RC receiver relay interface, VI-551
 - receiver/scanner preamp with MAR-1 MMIC, V-521
 - regenerative receiver, IV-449, VI-551, VI-554, VI-555
 - remote-control, V-510, V-513
 - rf input circuits, NE602, V-500
 - RS-232 to CMOS, III-102
 - S meter, V-311
 - shortwave receiver, IV-454, V-501, VI-540, VI-556
 - AM broadcast trap, VI-214
 - nine-band, VI-544-545
 - regenerative, one-tube, VI-546
 - toroidal core TRF, VI-543
 - noise limiter circuit, V-397
 - signal-reception alarm, III-270
 - signal-strength indicator, VI-260
 - SSB receiver, VI-80-meter, VI-29
 - superheterodyne receiver, IV-450-451, V-503, VI-21, VI-553
 - tracer, III-357
 - transceiver memory backup, VI-28
 - transceiver T/R switch, VI-610
 - transceiver/mixer, HF, IV-457
 - transmit/receive sequencer, preamp, V-348
 - twisted-pair video driver/receiver circuit, VI-682
 - two-band radio receiver, VI-548
 - ultrasonic, III-698, III-705, VI-670
 - CW transceiver, VI-669
 - ultrasound, Doppler, V-651
 - varioneter-tuned radio receiver, VI-557
 - VI.F whistler receiver, V-496
 - video line receiver, VI-550
 - voice-communication, light-beam, V-260
 - WWV receiver, VI-538-539, VI-558
 - zero center indicator for FM, I-338
 - recording devices (*see* tape-recorder circuits)
 - rectangular-to-triangular waveform converter, IV-116-117
 - rectifiers, II-527-528, III-536-537
 - absolute value, ideal full wave, II-528
 - averaging filter, I-229
 - bridge rectifier, fixed power supplies, IV-395
 - broadband ac active, IV-271
 - diodeless, precision, III-537, V-466
 - dual voltage-rectifier, V-464
 - full-wave rectifiers, IV-328, IV-650
 - averaging filter, V-191
 - op amp design, V-403
 - absolute value, II-528
 - precision, I-234, III-537
 - silicon-controlled (SCR), I-375
 - half-wave, I-228, I-230, II-528, IV-325
 - high-impedance precision, for ac/dc converter, I-164
 - inverter/rectifier, programmable op-amp design, IV-364
 - low-forward-drop, III-471
 - precision, I-422
 - silicon-controlled rectifiers (SCR)
 - annunciator, self-interrupting load, IV-9
 - chaser, III-197
 - crowbar, II-496
 - flashers, II-230, III-195, III-197
 - flip-flop, II-367
 - gas/smoke detector, III-251
 - preregulator, II-482
 - proximity alarm, III-517
 - radio control using, II-361
 - relaxation flasher, II-230
 - relaxation oscillator, III-430
 - ring counter, III-195
 - tester, III-344
 - time delay circuit with, II-670
 - triggering series, optically coupled, III-411
 - synchronous, phase detector-selector/balanced modulator, III-441
 - two-phase, VI-490
 - radial, electronic telephone set with, III-606
 - reference voltages, I-695, III-773-775, VI-339, VI-559-560
 - +10V, I-696
 - +3V, I-696
 - +5V, I-696
 - 0- to 20 V power, I-694, I-699
 - amplifier, I-36
 - bipolar output, precision, I-698
 - dual-output regulator, VI-564
 - dual tracking voltage, precision, I-698
 - high stability, I-696
 - logic control for 78xx regulator, VI-562
 - low-dropout, VI-566
 - low-noise buffered, precision, I-698
 - low-noise regulator, VI-565
 - low-power regulator, I-695
 - low-voltage reference, VI-560
 - micropower 10 V, precision, I-697
 - negative reference, VI-331, VI-560
 - positive voltage, VI-560, VI-567
 - power supply, buffered, VI-496
 - ripple reduction in switching regulator, VI-565
 - square wave voltage, precision, I-696
 - standard cell replacement, precision, I-699
 - step-down regulator, VI-563
 - surface-mount regulator, 3.3-V 1-A, VI-562
 - surface-mount switching regulator, 5- to 3.3-V, VI-567
 - switching regulator, VI-567
 - variable-voltage reference source, IV-327
 - reference clock, three phase clock from, II-101
 - reflection oscillator, crystal-controlled, III-136
 - reflectometer, I-16
 - regenerative receiver, one-transistor design, IV-449
 - registers, shift, I-380, II-366
 - driver, I-418
 - regulated power supplies
 - 8-amp, II-461
 - 10-amp, current/thermal protection, II-474
 - 12 to 14V at 3 A, II-480
 - 13.8-Vdc, 2 A, V-459
 - +15V 1 A, III-462
 - 15V 1 A, III-463
 - split power supplies, I-492
 - regulators (*see* voltage regulators)
 - Reinartz oscillator, VI-450
 - rejection filter, I-283
 - relaxation oscillator, III-430, IV-376
 - relays, II-529-532, IV-471-475, V-504-507, VI-568-572
 - ac relays
 - optically coupled, III-418
 - photon coupler in, II-412
 - solid-state latching, IV-472
 - AND circuit relay, VI-316
 - audio operated, I-608
 - battery charger relay fuse, V-88
 - bidirectional switch, IV-472
 - capacitance, I-130
 - carrier-operated relays (COR), I-575, IV-461
 - dark-activated, V-275, V-279
 - dc latching, optically coupled, III-417
 - delay-off circuit, IV-473
 - drivers, I-264
 - delay and controls closure time, II-530
 - with strobe, I-266
 - fast turn-on/delayed off relay, VI-572
 - fuse, V-478
 - high-impedance driver, VI-570
 - latching relay alarm circuit, VI-569
 - latching relay driver, VI-570, VI-571
 - latching relay, solid-state, V-505
 - light-beam operated on/off, I-366
 - light-sensitive, V-278, VI-304
 - low-frequency relay, VI-572
 - momentary relay, VI-569
 - monostable relay, low-consumption design, IV-473
 - optically coupled relays
 - ac, III-418
 - dc latching, III-417
 - optoisolator, IV-475
 - OR circuit relay, VI-316
 - polarity-protection for power supplies, IV-427
 - pulsar, sensor-activated, V-507
 - rf-actuated, III-270
 - ringer, telephone, III-606
 - solid-state relays, I-365, I-623, II-408, III-412, III-416, III-569-570, IV-472, IV-474, V-505-506
 - sound actuated, I-576, I-610
 - telephone, I-631
 - thermostatic relay circuit, VI-643, VI-645
 - time delayed, I-219, I-663, V-506
 - tone actuated, I-576
 - TR circuit, II-532
 - transistor relay driver, VI-571
 - triac, contact protection, II-531
 - remote control devices (*see also* infrared; radio-control circuits), IV-224, V-229, V-508-513
 - A/B switch, IR-controlled, V-225

- ac switch hookup, two-way, V-592
 - amplifier, I-99
 - analyzer, V-224
 - carrier, current, I-146
 - drop-voltage recovery for long-line systems, IV-328
 - extender, infrared, IV-227, V-512
 - fax/telephone switch, IV-552-553
 - infrared circuit, I-224
 - IR TV remote relay, VI-263
 - lamp or appliance, I-370
 - loudspeaker via IR link, I-343
 - loop transmitter for, III-70
 - on/off switch, I-577
 - receiver, V-510, V-513
 - ringer, telephone, III-614
 - sensor, temperature transducer, I-649
 - servo system, I-575
 - telephonic monitor, II-626
 - temperature sensor, II-654
 - tester, infrared, IV-228, V-228, V-229
 - thermometer, II-659
 - transmitter, V-509, V-513
 - interfacc, V-511
 - ultrasonic, V-512
 - transmitter/receiver, IR, I-342
 - ultrasonic tester, VI-667
 - video switch, IV-619-621
 - recapitators
 - beeper, I-19
 - European-type, tone burst generator for, III-74
 - fiberoptic link, I-270
 - telephonic, III-607
 - reset buttons
 - child-proof computer reset, IV-107
 - power-on, II-366
 - protection circuit for computer, IV-100
 - resistance controller, digital, V-159
 - resistance/continuity testers, I-550, I-551, II-342, II-533, II-534, II-535, III-345, III-538-540, IV-287, IV-289, IV-295, IV-296
 - audible, V-317
 - audible, adjustable, II-536
 - buzz box, I-551
 - cable tester, III-539
 - four-wire hookup, VI-335
 - latching design, IV-295
 - low-resistance circuits, V-319
 - ohmmeter, linear, III-540
 - PCB, II-342, II-535
 - ratiometric, I-550
 - RC decade box, V-294-295
 - resistance-ratio detector, II-342
 - single chip checker, II-534
 - visual, V-293
 - resistance-to-voltage converter, I-161-162
 - resistors
 - multiplier, II-199
 - programmable, VI-363
 - simulator, 100-W, VI-352
 - voltage-controlled, I-422
 - resonator oscillator, varactor tuned
 - 10 MHz ceramic, II-141
 - restorer, video dc, III-723
 - reverb effect
 - analog delay line, IV-21
 - stereo system, I-602, I-606
 - reversing motor drive, dc control signal, II-381
 - rf amplifiers, II-537-549, III-542-547, IV-476-493, V-514-527
 - 1 W, 2.3 GHz, II-540
 - 2 meter FET power amplifier, V-521
 - 10 W, 225-400 MHz, II-548
 - 10-W, 10-M linear amplifier, V-520
 - 10 dB-gain, III-543
 - 2- to 30 MHz, III-544
 - 4 W amp for 900 MHz, IV-477
 - 5 W 150-MHz, III-546
 - 5 W power, II-542
 - 6-meter kilowatt, II-545
 - 6-meter preamp, 20 dB gain and low-NF, II-543
 - 20-W, V-1296-MHz module, V-522
 - 20-W, V-450 MHz amplifier, V-519
 - 30-MHz, V-519
 - 60 W 225-400 MHz, III-547
 - 125 W, 150 MHz, II-544
 - 455-kHz IF amplifier, V-522, V-523, V-524
 - 500 MHz, IV-491
 - 1.296 MHz, IV-486
 - 1,500 W, IV-478-479
 - AGC, wideband adjustable, III-545
 - broadcast-band, II-546, III-264, IV-487, V-516, V-517
 - buffer amplifier with modulator, IV-490
 - cascode amplifier, IV-488
 - common-gate, 450-MHz, III-544
 - GAsFET preamplifier, V-435 MHz, V-516
 - HF preamplifier, V-515
 - HP/VHF switchable active antenna, V-524
 - IF amplifier, 455-kHz, V-522, V-523, V-524
 - IF amplifiers, 45-MHz, crystal filter, V-527
 - isolation amplifier, II-547
 - LC tuned, V-525
 - linear amplifiers, IV-480-485, V-520
 - low-distortion 1.6 to 30 MHz SSB driver, II-538
 - meter-driver, 1-MHz, III-545
 - MOSFET rf-amp stage, dual-gate, IV-489
 - power amplifiers, I-559, II-542, III-542, V-517, V-519, V-521, V-525
 - preamplifiers, V-527
 - GasFET, V-516
 - HF, V-515
 - receiver/scanner with MAR-1 MMIC, V-521
 - VHF/UHF, V-515
 - wideband, V-526
 - preselectors, IV-483, IV-485, IV-488
 - receiver/scanner preamp with MAR-1 MMIC, V-521
 - TV sound system, V-519
 - UHF, V-523
 - UHF-TV amp/preamp, III-546, IV-482, IV-483
 - VHF/UHF preamplifier, V-515
 - wideband amplifiers, IV-479, IV-489, IV-490-493, V-518, V-519, V-526
 - rf circuits (see radio/rtf)
 - RGB video amplifier, III-709
 - RGB-composite video signal converter, III-714
 - RGB-to-NTSC converter, IV-611
 - RTAA line amplifier/driver, VI-77
 - RTAA preamp, VI-80
 - ring counters
 - 20 kHz, II-135
 - incandescent lamps, I-301
 - low-cost, I-301
 - pulse circuit, low-power, IV-437
 - SCR, III-195
 - variable timing, II-134
 - ring launcher game, electromagnetic, V-209
 - ring-around flasher, LED, III-194
 - ringers, telephone, I-628, IV-556
 - detectors, ring detectors, I-634, I-635, III-611, III-619
 - extension-phone ringer, IV-561
 - high-isolation, II-625
 - multi-tone, remote programmable, II-634
 - musical, II-619
 - piezoelectric, I-636
 - plug-in, remote, II-627
 - relay, III-606
 - remote, II-627, III-614, IV-562
 - silencer, IV-557
 - tone, I-627, I-628, II-630, II-631
 - ripple suppressor, IV-175
 - fixed power supplies, IV-396
 - RLC oscillator, III-423
 - rms-to-dc converter: I-167, II-129
 - thermal, 50-MHz, III-117
 - true rms detector, I-228
 - road ice alarm, II-57
 - robots
 - eyes for, II-327
 - light-seeking, II-325
 - rocket launcher, II-358
 - RON compensator, op amp and analog switch, VI-605
 - room monitor, V-369
 - root extractor, V-207, V-288
 - rotation detector, II-283
 - roulette, electronic, II-276, IV-205
 - RS-232 interface
 - CMOS-to, line receiver, III-102
 - datasector, automatic, III-97
 - drive circuit, low-power, III-175
 - LED circuit, III-103
 - line-driven CMOS circuits, IV-104
 - RS flip-flop, I-395
 - RTD signal conditioners
 - 5V powered linearized platinum, II-650
 - precision, linearized platinum, II-639
 - RTTY machines, fixed current supply, IV-400
 - rumble filters, III-192, III-660, IV-175
 - LM387 in, I-297
 - turntable, IV-170
- S**
- S meter, III-342, V-311
 - safe area protection, power amplifier with, III-459
 - safety circuits (see protection circuits)
 - safety flare, II-608
 - Sallen-Key filters
 - 10 kHz, I-279
 - 500 Hz bandpass, I-291
 - current driven, V-189
 - high pass, VI-209
 - low pass, VI-221
 - active, IV-177
 - equal component, I-292
 - second order, I-289
 - sample-and-hold circuits, I-590, II-552-559, III-548-553, IV-502-503, V-533-534, VI-573-574

sample-and-hold circuits *continued*
 x 1000, I-589
 4-channel micropower, VI-574
 charge-compensated, II-559
 de-glitch circuit, V-336-337
 fast and precise, II-556
 filtered, III-550
 frequency-to-voltage conversion,
 IV-194
 high-accuracy, I-590
 high-performance, II-557
 high-speed, I-587-588, I-590, III-550
 infinite, II-558
 inverting, III-552
 JFET, I-586
 low-drift, I-586, VI-574
 offset adjustment for, I-588
 three-channel multiplexer with, III-
 396
 track-and-hold, III-549, III-552
 sampling circuit
 hour time delay, II-668
 RF line sampler/coupler, VI-30
 saturated standard cell amplifier, II-
 296
 saw filter, VI-222
 sawtooth waves, VI-575-577
 converter, IV-114
 generator, VI-577
 digital design, IV-444, IV-446, V-491
 linear, V-205
 op amp design, VI-576, VI-701
 triggered, V-204
 oscillator modulator, III-373
 pulse generator and, III-241
 SCA (*see* silicon-controlled
 amplifiers)
 scale, I-398, V-297
 scaler, inverse, I-422
 scanner, bar codes, III-363
 scanners, VI-578-580
 FM scanner noise squelch, VI-579
 receiver/scanner preamp with MAR-
 1 MMIC, V-521
 shortwave converter for scanner,
 VI-580
 silencer circuit, VI-579
 Schmitt triggers, I-593, III-153, V-356
 crystal oscillator, I-181
 programmable hysteresis, I-592
 square-wave generators, V-569, V-
 570
 transistorized, V-204
 TTL-compatible, II-111
 without hysteresis, I-592
 SCR (*see* silicon-controlled rectifiers)
 scramblers, audio (*see also* sound
 generators; voice-activated
 circuits), IV-25-27
 telephone, II-618
 voice scrambler/descrambler, IV-26,
 IV-27
 scratch filters, III-189, IV-175
 LM287 in, I-297
 second-audio program (SAP)
 adapter, III-142
 security circuits (*see* alarms;
 annunciators)
 sense-of-slope tilt meter, II-664
 sensors (*see* alarms; fluid and
 moisture; light controlled
 circuits; motion/proximity
 detectors; motor control circuits;
 smoke detectors; speed
 controllers; temperature-related
 circuits; tone controls)
 sequence indicator, phase, I-476
 sequencer, pseudorandom, III-301
 sequential flashers, I-109, II-233, II-
 238
 sequential timer, III-651
 series connectors, telephone, III-609
 servo amplifiers (*see also* motor
 controls), I-452
 400 Hz, II-388
 bridge type ac, I-458
 dc, I-457
 motor drive amplifier, II-384
 servo systems (*see also* motor
 controls)
 controller, III-384
 remote control, I-575
 shaper, sine wave, II-561
 shielding, shield/line driver, high-
 speed, VI-198
 shift registers, I-380, II-366
 driver for, I-418
 shifter, phase (*see* phase)
 ship siren, electronic, II-676
 short-circuit proof lamp driver, II-310
 short-circuit protection circuit, VI-526
 short-circuit tester/sensor, V-315
 computer remote data lines, IV-102
 for 120-V equipment, V-313
 shortwave transmissions
 AM broadcast trap, VI-214
 AM and shortwave, ac/dc vacuum-
 tube design, VI-536-537
 converters, III-114, IV-500, V-118
 FET booster, I-561
 IF filter for shortwave receiver, VI-
 212
 interference trap, VI-214
 noise limiter, V-397
 notch filter, V-185
 pulsed marker rf oscillator, V-532
 receiver, IV-454, V-501, VI-540, VI-
 543, VI-544-545, VI-546, VI-556
 scanner converted to shortwave,
 VI-580
 shunt, multimeter shunt, IV-293
 shutdown circuits (*see* protection
 circuits)
 shutoff, automatic, battery-powered
 projects, III-61
 shutter speed tester, II-445
 sidetone oscillator, rf-powered, I-24
 signal amplifiers, audio, II-41-47, IV-
 34-42
 signal attenuator, analog,
 microprocessor-controlled, III-
 101
 signal combiner, III-368
 signal conditioners, IV-649
 5V powered linearized platinum
 RTD, II-650
 bridge circuit, strain gauge, II-85
 linearized RTD, precision design, II-
 639
 LVDT, II-338
 thermally stabilized PIN
 photodiode, II-330
 signal distribution amplifier, I-39
 signal generators (*see* function
 generators; sound generators;
 waveform generators)
 signal injectors, III-554-555
 signal sources, crystal-controlled, II-
 143
 signal tracer, V-309
 three-in-one set: logic probe, signal
 tracer, injector, IV-429
 signal-strength meters, III-342, IV-
 166
 silent alarm, V-16
 silicon-controlled amplifiers (SCA),
 V-535
 converter, VI-151
 decoder, I-214, II-166, II-170
 demodulator, II-150, III-565
 MPX-SCA receiver, III-530
 subcarrier adapter for FM tuners,
 V-536
 silicon-controlled rectifiers (SCR)
 circuits
 annunciator, self-interrupting load,
 IV-9
 chaser, III-197
 crowbar, II-496
 flashers, II-230, III-197
 chaser, III-197
 relaxation, II-230
 ring counter, III-195
 flip-flop, II-367
 full-wave, I-375
 gas/smoke detector, III-251
 inverter and trigger, VI-283
 motor speed controller, VI-414
 preregulator, II-482
 proximity alarm, III-517
 radio control using, II-361
 relaxation flasher, II-230
 relaxation oscillator, III-430
 ring counter, III-195
 tester, III-344
 time delay circuit with, II-670
 triggering series, optically coupled,
 III-411
 switching supply for color TV, VI-
 487
 simulators
 EKG, three chip, III-350
 inductor, II-199
 VOR signals, IV-273
 sine approximation circuit, VI-323
 sine-to-square wave converter, IV-
 120, V-124, V-125, V-569, V-570
 sine-wave converter, VI-150
 sine-wave descrambler, II-163
 sine-wave generators, IV-505, IV-506,
 V-542, V-543, V-544, VI-701
 60 Hz, IV-507
 audio, II-564
 battery powered, V-541
 LC, IV-507
 LF, IV-512
 oscillator, audio, III-559
 square-wave and, tunable oscillator,
 III-232
 VLF audio tone, IV-508
 sine-wave inverter, VI-285
 sine-wave oscillators, I-65, II-560-570,
 III-556-559, III-560, IV-504-513,
 V-539-544, VI-433
 1-Hz, V-542
 60-Hz, highly stable, V-540
 555 used as RC audio oscillator, II-
 567
 adjustable, II-568
 audio, II-562, II-564, III-559
 generators (*see* sine-wave
 generators)
 LC oscillator, low-frequency, IV-509
 logic gate design, VI-440
 low-distortion, II-561, VI-436
 one-IC audio generator, II-569
 phase-shift, audio ranging, IV-510
 programmable-frequency, III-424

relaxation, modified UJT for clean audio sinusoids, II-566
 shaper, sine-wave, V-543
 sine wave shaper, II-561
 sine/square wave TTL oscillator, IV-512
 two-tone generator, II-570
 two-transistor design, IV-508
 variable, super low-distortion, III-558
 very-low-distortion design, IV-509
 voltage-controlled oscillator, V-666
 Wien-bridge, I-66, I-70, II-566, IV-510, IV-513, V-541
 sine-wave output buffer amplifier, I-128
 sine/cosine generator, II-260, VI-700
 sine/square wave converter, I-170
 sine/square wave oscillators, I-65
 easily tuned, I-65
 TTL design, IV-512
 tunable, III-232
 sinks (*see* current sources)
 single-pulse generator, II-175
 single-sideband (SSB)
 communications
 CW/SSB product detector, IV-139
 CW/SSB receiver, V-499
 driver, low-distortion 1.6 to 30 MHz, II-538
 generators, IV-323
 receiver, 80-meter, VI-29
 transmitter, crystal-controlled LO for, II-142
 sirens (*see also* alarms; sound generators), I-606, II-571, III-560-568
 alarm using, II-572, II-573, IV-514-517, VI-581-584
 7400, II-575
 adjustable-rate programmable-frequency, III-563
 electronic, III-566, IV-515, IV-517, VI-583
 fire siren, VI-582
 generator for, II-572
 hee-haw, II-578, III-565
 high-power, II-578
 linear IC, III-564
 low-cost design, IV-516
 multifunction system for, II-574
 ship, electronic, II-576
 sonic defender, IV-324
 Star Trek red alert, II-577
 tone generator, II-573
 toy, II-575
 TTL gates in, II-576
 two-state, III-567
 two-tone, III-562, VI-584
 varying frequency warning alarm, II-579
 wailing, III-563, VI-583
 warble-tone siren, IV-515, IV-516, V-7, VI-582
 whooper, IV-517
 yelp oscillator, II-577, III-562
 slave-flash trigger, IV-380, IV-382
 slide timer, III-444, III-448
 slot machine, electronic, V-211
 smart clutch, auto air conditioner, III-46
 smoke alarms and detectors, II-278, III-246-253
 gas, I-332
 ionization chamber, I-332-333
 line-operated, IV-140
 operated ionization type, I-596
 photoelectric, I-595, I-596
 sniffers
 heat, electronic, III-627
 rf, II-210
 snooper, FM, III-680
 socket debugger, coprocessor, III-104
 soil heater for plants, V-333
 soil moisture meter, III-208
 solar circuits (*see* photodiode/photoelectric circuits)
 soldering iron control, V-327
 soldering station, IR-controlled, IV-225
 solenoid drivers, I-265, III-671-673, VI-202
 12-V latch, III-572
 hold-current limiter, III-573
 power-consumption limiter, III-572
 solid-state devices
 ac relay, III-570
 electric fence charger, II-203
 high-voltage supply, remote adjustable, III-486
 light sources, V-282-283
 load-sensing switch, V-285
 relays, III-569-570, V-505, V-506
 stepping switch, II-612
 switch, line-activated, telephone, III-617
 sonic defender, IV-324
 sound-activated circuits (*see* sound-operated circuits)
 sound effects (*see* sound generators)
 sound generators (*see also* burst generators; function generators; sirens; waveform generators), I-605, II-585-593, III-559-568, III-575, IV-15-24, IV-518-524, V-394-395, V-556-567, VI-585-592
 acoustic field generator, V-338-341
 alarm-tone generator, V-563
 amplifier, voltage-controlled, IV-20
 amplifier/compressor, low-distortion, IV-24
 allophone, III-733
 audio-frequency generator, V-416-417
 audio tone generator, VLI^F, IV-508
 autodrum, II-591
 bagpipes, electronic, III-561, IV-521
 beat-frequency, IV-371
 beeper, V-558
 bird chirp, I-605, II-588, III-577, VI-589
 bongos, II-587
 canary simulator, V-557
 chime generator, II-604, IV-624
 chug-chug, III-576
 color organ, VI-193
 complex sound-effect generator, VI-586
 dial tone, I-629, III-609
 ditherizing circuit, digital audio use, IV-23
 doorbell, musical tones, IV-522
 doubler, audio-frequency doubler, IV-16-17
 dual-tone sounder, V-564, VI-390, VI-587
 echo and reverb, analog delay line, IV-21
 electronic, III-360
 envelope generator/modulator, II-601
 equalizer, IV-18
 fader, IV-17
 fish lure, electronic, VI-386
 frequency-shift keyer, tone-generator test circuit, I-723
 funk box, II-590
 fuzz box, II-590, III-575
 gong, electronic, V-563
 guitar compressor, IV-519
 gunshot sound effect, VI-592
 harmonic generator, I-24, IV-649
 high-frequency signal, III-150
 hold for telephone, II-623
 instrument tune-up, audio generator, V-390
 laser pistol sound effect generator/receiver, VI-292
 low-level sounder, V-564
 mating circuit, VI-383
 noise generators, I-467, I-468, I-469, IV-308, V-395, VI-421
 octave-shifter for musical effects, IV-523
 one-IC design, II-569
 perfect pitch circuit, V-391
 phasor sound generator, IV-523
 pink noise, I-468
 portable, I-625
 pulse echo driver, VI-380
 pulsed-tone alarm, V-559
 quad tone oscillator, VI-434
 race-car motor/crash, III-578
 robotic chatter, VI-590-591
 run-down clock for games, IV-205
 sound effects, III-574-578
 siren, V-559, V-565, V-567
 sound-effects generator, V-565
 sound subcarrier generator, VI-358
 space-age sound machine, V-562
 spaceship alarm, V-560
 speech detectors, II-617, III-615
 steam locomotive whistle, II-589, III-568
 steam train/prop plane, II-592
 stereo system, derived center-channel, IV-23
 super, III-564
 surf sound generator, VI-588
 synthesizer, II-599, V-561
 telephone call-tone generator, IV-562
 telephone ringer, II-619
 tone burst generator, VI-375
 tone burst generator, repeater, V-629
 tone chime, V-560
 tone generators, I-604, I-625
 top octave generator, V-393
 Touchtone dial-tone, telephone, III-609
 train chuffer, II-588
 tremolo circuits, III-692-695, IV-589
 twang-twang, II-592
 two-tone, II-570, V-629, VI-584
 ultrasonic sound source, IV-605
 very-low-frequency, I-64
 vocal eliminator, IV-19
 voice circuits, III-729-734
 waa-waa circuit, II-590
 wailer, VI-583
 warbling tone, II-573, VI-582
 whistle, VI-589
 white noise generators, IV-201, VI-705-706
 wind chimes, VI-591

sound-operated circuits (*see also* ultrasonic circuits; voice-operated circuits), II-580-584, III-579-580, IV-525-528, V-545-555
 amplifier, gain-controlled, IV-528
 color organ, II-583, II-584
 decoder, III-145
 fader, V-549
 flash triggers, I-481, II-449, IV-382
 kaleidoscope, sonic, V-548-549
 lights, I-609, V-552
 memo alert, V-352
 noise clipper, I-396
 relay, I-608, I-610
 sleep-mode circuit, V-547
 switch, II-581, III-580, III-600, III-601, IV-528-527, V-553, V-555, V-590, VI-613
 ac, II-581
 two-way, I-610
 voice-operated, III-580, IV-527
 speech activity detector, telephone, III-615
 voice-operated switch, III-580
 vox box, II-582
 whistle-activated switch, V-551
 sources (*see* current sources; voltage sources)
 source followers
 bootstrapped, V-20
 JFET, V-20
 photodiode, III-419
 SPDT switch, ac-static, II-612
 space-age sound machine, V-562
 space war, I-606
 spaceship alarm, V-560
 speaker systems
 FM carrier current remote, I-140
 hand-held transceiver amplifiers, III-39
 overload protector for, II-16
 protection circuit, V-476, V-479
 wireless, IR, III-272
 speakerphone, II-611, III-608
 spectrum analyzer adapter, oscilloscopes, V-424
 speech-related circuits
 activity detector, II-617, III-619
 compressor, II-15
 filter
 300 Hz-3 kHz bandpass, I-295
 second-order, 300-to-3,400 Hz, IV-174
 speech-range bandpass filter, V-185
 two-section, 300-to-3,000 Hz, IV-174
 network, II-633
 scrambler, V-554
 speed alarm, I-95
 speed controllers (*see also* motor control), I-450, I-453, II-378, II-379, II-455, V-380, V-381, VI-412, VI-414
 accelerometer, VI-345
 back EMP PM, II-379
 cassette-deck motor speed calibrator, IV-353
 closed-loop, III-385
 dc motor speed controller, VI-411
 fans, automatic, III-382
 feedback speed, I-447
 dc motors, I-452, I-454, III-377, III-380, III-388, VI-415
 dc variable, fiberoptic, II-206
 feedback, I-447
 fixed, III-387
 high-efficiency, III-390
 high-torque motor, I-449
 light-activated/controlled, IV-247
 load-dependent, I-451
 model trains and/or cars, I-453, I-455, IV-338-340
 motor (*see* motor controls; tachometers)
 power tool torque, I-458
 PWM, II-376, III-380, V-381
 radio-controlled, I-576
 series-wound motors, I-448, II-456
 shunt-wound motors, II-456
 stepper motors, direction and speed control, IV-350
 switched-mode, III-384
 tachometers, I-94, I-100, I-102, II-175, III-335, III-340, III-347, VI-98, VI-298, VI-371
 analog readout, IV-280
 calibrated, III-598
 closed loop feedback control, II-390
 digital readout, II-61, III-45, IV-268-269, IV-278
 dwell meter/tachometer, III-45
 feedback control, II-378, II-390
 frequency counter, I-310
 low-frequency, III-596
 minimum-component design, I-405
 motor speed controllers, II-378, II-389
 optical pick-up, III-347
 set point, III-47
 tachometerless, III-386, IV-349
 tools and appliances, I-446
 universal motors, I-457, II-451
 speed warning device, I-96, I-101
 speedometers, bicycle, IV-271, IV-282
 splitters, III-581-582
 battery, III-66
 phase, precision, III-582
 precision phase, I-477
 voltage, III-738, III-743
 wideband, III-582
 squarer, precision, I-615
 square-root circuit, VI-319, VI-320, VI-322
 square-wave generators, II-594-600, III-583-585, IV-529-536, V-568-570, VI-593-594
 1 kHz, IV-536
 2 MHz using two TTL gates, II-598
 10-Hz to 10-kHz VCO, V-570
 60-Hz, V-569
 555 timer, II-595
 astable circuit, II-597, IV-534
 CMOS 555 astable, true rail-to-rail, II-596
 duty-cycle multivibrator, III-50-percent, III-584
 four-decade design, IV-535
 high-current oscillator, III-585
 line frequency, II-599
 low-frequency TTL oscillator, II-595
 multiburst generator, II-88
 multivibrator, IV-536
 oscillators, I-613-614, II-597, II-616, IV-532, IV-533, V-569
 0.5 Hz, I-616
 1 kHz, I-612
 frequency doubled output, II-596
 phase-tracking, three-phase, II-598
 pulse extractor, III-584
 quadrature-outputs oscillator, III-585
 Schmitt trigger, V-569, V-570
 sine-wave and, tunable oscillator, III-232
 sine-to-square wave converter, V-569, V-570
 three-phase, II-600
 tone-burst generator, single timer IC, II-89
 triangle-wave and, III-239
 precision, III-242
 programmable, III-225
 wide-range, III-242
 TTL, LSTTL, CMOS designs, IV-530-532
 variable duty-cycle, IV-533
 variable-frequency, IV-535, V-570
 square wave oscillator, VI-445
 astable multivibrator and, V-386
 square-to-sine wave converters, III-118
 squelch circuits, II-394
 AM/FM, I-547
 FM scanner noise squelch, VI-579
 voice-activated circuits, IV-624
 squib firing circuits, II-357
 stabilizers, fixed power supplies, IV-393, IV-406
 staircase generators (*see also* function generators; waveform generators), I-730, II-601-602, III-586-588, IV-443-447, VI-595-599
 free-running, VI-598
 stepped triangle wave, VI-596
 up-down staircase, VI-599
 video staircase generator, VI-597
 stand-by power supply, non-volatile CMOS RAMs, II-477
 standard, calibration, I-406
 standard-cell amplifier, saturated, II-296
 standing wave ratio (SWR)
 detector adapter, audible signal, VI-25
 meter, IV-269
 power meter, I-16
 QRP bridge, III-336
 warning indicator, I-22
 Star Trek red alert siren, II-577
 start-and-run motor circuit, III-382
 state-of-charge indicator, lithium battery, II-78
 state-variable filters, II-215, III-189, VI-209
 multiple outputs, III-190
 second-order, 1 kHz, Q/10, I-293
 single 3.3-V supply, 4-pole, VI-216
 universal, I-290
 static detector, IV-276
 steam locomotive sound effects, II-589, II-592, III-568
 step-up switching regulator, 6V battery, II-78
 step-up/step-down dc-dc converters, III-118
 stepper motors (*see also* motor control circuits), V-571-573, VI-600-602
 direction control, IV-350
 drivers, II-376, II-390
 bipolar, V-572
 FET-based, V-573
 half-step, IV-349
 quarter-step, IV-350

dual clock circuit, V-573
 encoder circuit, VI-602
 pulse generator, VI-601
 shaft encoder use, VI-601
 speed and direction, IV-350
 stepping switch, solid state, II-612
 stereo/phonograph (hi-fi) circuits, V-574-584
 acoustic field generator, V-338-341
 amplifiers, I-77, I-80-81, I-89, I-670, II-9, II-43, II-45, III-34, III-37, III-38, IV-29, IV-35, IV-36, IV-66, VI-75
 bass tone control, V-584
 mini-stereo amplifier, V-583
 audio level meter, IV-310
 audio power amplifiers, V-40, V-48, VI-90
 audio power meter, IV-306
 audio signal amplifier, V-58
 balance circuits, I-618-619, II-603-605, V-583
 booster amplifier for car stereo, V-72
 compander, II-12, III-93, III-95
 expander, II-13, III-93, III-95, V-582
 decoders, II-18, II-167-169, VI-170
 demodulators, I-544, II-159
 derived center channel stereo system, IV-23
 FM bug, VI-662
 FM stereo transmitter, V-575, V-580, VI-662
 frequency decoder, II-169
 frequency division multiplex, II-169
 level display circuit, VI-190
 line driver, VI-198
 loudspeaker protector circuit, V-483
 mixers, I-55, IV-332
 power meter, III-331
 preamplifiers, I-90, I-91, II-43, II-45, III-37, III-671, III-673, IV-35, IV-36, V-581, V-584, VI-79
 reception indicator, III-269
 reverb systems, I-602, I-606, II-9
 RIAA phono amplifier, VI-89
 speaker driver, TTL-based, VI-199
 speaker protection circuit, V-476, V-479
 TDM decoder, II-168
 test circuits, I-618-619, III-269, III-331, IV-306, IV-310
 tone control circuit, high-Z input, I-676
 TV-stereo decoder, II-167, V-576-579, V-580
 volume limiter, VI-376
 stethoscope for automobiles, VI-95
 stimulator, constant-current, III-352
 -stimulus isolator, III-351
 stop light, garage, II-53
 strain gauges, VI-336
 bridge excitation, III-71
 bridge signal conditioner, II-85
 instrumentation amplifier, III-280
 strobe circuits, II-606-610, VI-468
 alarm system, V-6-7
 disco, II-610
 high-voltage power supplies, IV-413
 safety flare, II-608
 tone burst generator, II-90
 trip switch, sound activated, I-483
 variable strobe, III-589-590
 stud finder, III-339
 subharmonic frequencies, crystal-stabilized IC timer, II-151
 subtractor circuit, III-327
 subwoofer amplifier, V-49, V-50
 successive-approximation A/D converter, I-45, II-24, II-30
 summing amplifiers, I-37, III-16
 fast action, I-36
 inverting, V-18, V-20
 precision design, I-36
 video, clamping circuit and, III-710
 sun tracker, III-318
 superheterodyne receivers, VI-553
 3.5-to-10 MHz, IV-450-451
 amateur radio, four-stage 75-meter, VI-21
 supply rails, current sensing in, II-153
 suppressed-carrier, double-sideband, modulator, III-377
 sweep generators (see also function generators; waveform generators), VI-238-241
 10.7 MHz, I-472
 add-on triggered, I-472
 oscilloscope-triggered, III-438
 switches and switching circuits, II-611-612, III-591-594, IV-537, V-585-593, VI-603-614
 ac switches, III-408, IV-387
 ac power switch, V-112, V-115
 analog switches, I-621, I-622, III-593, VI-604, VI-607, VI-609, VI-614
 antenna selector, electronic, IV-538-539
 audio switch, eight-channel, V-588-589
 audio-controlled switch, V-590, VI-613
 audio/video switcher circuit, IV-540-541
 auto off power switch, VI-611
 auto-repeat switch, bounce-free, IV-545
 bandswitching for receiver, VI-608
 bidirectional relay switch, IV-472
 bistable switch, mechanically controlled, IV-545
 closure circuit, VI-182
 contact, I-136
 controller, III-383
 dark-activated, V-274, V-276
 dc controlled, V-586, V-592
 dc static, II-367
 debouncers, III-592, IV-105, IV-106, IV-108, V-316, VI-387, VI-613, VI-614
 delay, auto courtesy light, III-42
 delay circuit for switch on, VI-611
 dimmer switches, I-369, II-309, IV-247, IV-249
 800 W, II-309
 dc lamp, II-307
 four-quadrant, IV-248-249
 halogen lamps, III-300
 headlight, II-57, II-63
 low-cost, I-373
 soft-start, 800-W, I-376, III-304
 landcm, II-312
 triac, I-375, II-310, III-303
 DTL-TTL controlled buffered analog, I-621
 fax/telephone switch, IV-552-553
 FET, dc controlled, V-592
 PET dual-trace (oscilloscope), II-432
 flex switch, alarm sounder circuit, V-15
 frequency switcher/oscillators, V-418
 Hall-effect, III-257, IV-539
 headlight switching circuit, V-75
 hexFET switch, V-592, V-593, VI-612
 high-frequency, I-622
 high-side power control switch, 5 V supply, IV-384, IV-385
 infrared-activated, IV-345
 inverter, analog, VI-604
 IR-controlled A/B switch, V-225
 isolated switch, VI-604
 kill-switch for batteries, V-71-72
 latching, SCR-replacing, III-593
 light-operated, II-320, III-314, V-274, V-278
 adjustable, I-362
 capacitance switch, I-132
 light-controlled, II-320, III-314
 photoelectric, II-321, II-326, III-319
 self-latching, V-278
 solar triggered, III-318
 zero-point triac, II-311
 load-disconnect switch, V-591
 load-sensing, solid-state, V-285
 mercury-switch tilt detector, V-302
 MOSFET power control switch, IV-386
 multiplexer, low output impedance, VI-605
 on/off inverter, III-594
 on/off switch, I-577, II-359, IV-543, IV-546, VI-612
 optical safety-circuit switch, V-409
 optically coupled, III-408, III-410
 oscillator-triggered switch, V-590, VI-606
 over-temperature switch, IV-571
 photo cell memory, ac power control, I-363
 photoelectric, II-321, II-326
 PIN diode switch, VI-609
 proximity, III-517
 push on/off, II-359
 pushbutton power control switch, IV-388
 remote switches, I-577, I-630, V-592
 resistor PIN-diode switch, VI-608
 rf switches, III-361, III-592
 RON compensator, op amp and analog switch, VI-605
 rotary switch, BCD digital, V-160
 safety switch, V-589
 satellite TV audio switcher, IV-543
 series/shunt PIN-diode RF switch, VI-610
 shunt PIN-diode switch, VI-607
 solar-triggered, III-318
 solid-state stepping, II-612
 sonar transducer, III-703
 sound-activated, I-610, II-581, III-580, III-600, III-601, IV-526-527, V-553, V-555, V-590
 speed, I-104
 SPDT, ac-static, II-612
 switching controller, III-383
 temperature control, low-power, zero-voltage, II-640
 thermostatic, for auto fan, V-68
 tone switch, narrowband, IV-542
 touch switches, I-131, I-135-136, II-

switches and switching circuits

continued

- 690-693, III-661-665, IV-590-594, V-270
 - touchomatic, II-693
 - TR switch for antennas, automatic, V-37
 - transceiver T/R switch, VI-610
 - triac switches, I-623, II-311, IV-253
 - two-channel, I-623
 - two-way switch wiring, V-591
 - ultrasonic, I-683
 - under-temperature switch, IV-570
 - VHF/UHF diode rf switch, IV-544
 - video switches, III-719, III-725, III-727, III-728, IV-618-621, V-587, VI-680
 - video/audio switch, V-586
 - voice-operated, I-608, III-580, IV-527, V-553
 - whistle-activated switch, V-551
 - wiring for two-way switch, V-591
 - zero crossing, I-732, VI-606
 - zero point, I-373, II-311
 - zero-voltage switching, I-623, III-410, III-412
 - switched-mode power supplies, II-470, III-458, VI-479
 - 24- to 3.3-V, V-462
 - 5- to 3.3-V, V-462
 - 50 W, off-line, III-473
 - 100 kHz, multiple-output, III-488
 - color TV receiver, SCR, VI-487
 - control circuits, VI-494
 - converter, V-461
 - synchronous stepdown regulator, V-468
 - voltage regulators for switched supplies, V-453, VI-484
 - 3 A, III-472
 - 5 V, 6 A, 25 kHz, separate ultrastable reference, I-497
 - 6 A variable output, I-513
 - 200 kHz, I-491
 - application circuit, 3W, I-492
 - fixed power supplies, 3 A, IV-408
 - high-current inductorless, III-476
 - low-power, III-490
 - multiple output MPU, I-513
 - positive, I-498
 - step down, I-493
 - step-up, 6V battery, II-78
 - converter, +50V push pull, I-494
 - inverter, 500 kHz, 12 V, II-474
 - power amplifier, I-33
 - switched light, capacitance, I-132
 - switching/mixing, silent audio, I-59
 - sync circuits, V-594-595, VI-615-618
 - combiner, V-595
 - gating circuit, V-595
 - PLD synchronizes asynchronous inputs, VI-616
 - separators, III-715, IV-616
 - stretcher circuit, VI-618
 - sync tip dc restorer, VI-617
 - synthesizers (*see also* musical circuits; sound generators)
 - four-channel, I-603
 - frequency, programmable voltage-controlled, II-265
 - music, I-599
- T**
- tachometers, I-94, I-100, I-102, II-175, III-335, III-340, III-347, V-65, V-596-598, VI-98, VI-298, VI-371
 - adapter, VI-298
 - analog readout, IV-280, V-597-598
 - calibrated, III-598
 - closed loop feedback control, II-390
 - digital readout, II-61, III-45, IV-268-269, IV-278
 - dwell meter/tachometer, III-45
 - feedback control, II-378, II-390
 - frequency counter, I-310
 - low-frequency, III-596
 - minimum-component design, I-405
 - motor speed controllers, II-378, II-389
 - optical pick-up, III-347
 - set point, III-47
 - signal-conditioning circuit, VI-98
 - tandem dimmer, II-312
 - tap, telephone, III-622
 - tape-recorder circuits, I-21, I-419, III-599-601, IV-547-548
 - amplifiers, I-90, IV-36
 - audio-powered controller, IV-548
 - automatic tape-recording switch, I-21, II-21
 - automotive-battery power circuit, IV-548
 - cassette-deck motor speed calibrator, IV-353
 - extended-play circuit, III-600
 - flat-response amplifier, III-673
 - interface for, II-614
 - personal message recorder, V-330-331
 - playback amplifier, III-672, IV-36
 - position indicator/controller, II-615
 - preamplifier, I-90
 - sound-activated switch, III-600, III-601
 - starter switch, telephone-activated, I-632
 - telephone-activated starter switch, I-632, II-622, III-616
 - telephone-to-cassette interface, III-618
 - telecom converter -48 to +5 V at 1 A, V-472
 - telemetry demodulator, I-229
 - telephone-related circuits (*see also* intercoms), II-616-635, III-602-622, IV-549-564, V-599-615, VI-619-628
 - alarm dialer, V-612
 - amplifier, III-621, IV-560, V-614
 - answering machine beeper, IV-559
 - auto answer and ring indicator, I-635
 - automatic recording device, II-622
 - basic telephone circuit, V-615
 - bell simulator, V-604
 - Bell System 202 data encoder, VI-625
 - blinking phone light monitor, II-624, II-629
 - call-tone generator, IV-562
 - call restrictor, VI-622
 - caller ID, V-613, VI-621
 - cassette interface, III-618
 - converter, ultra low-power for personal communications, VI-166
 - decoder, touch-tone, IV-555
 - dial pulse indicator, III-613
 - dial-tone circuit, 5-V, V-610
 - diald-phone number vocalizer, III-731
 - dialer
 - emergency dialer, V-603
 - pulse/tone, single-chip, III-603
 - dual tone decoding, II-620
 - duplex audio link, IV-554
 - duplex line amplifier, III-616
 - eavesdropper, wireless, III-620
 - emergency dialer, V-603
 - fax-machine switch, remote-controlled, IV-552-553
 - flashers, II-629
 - phone-message, IV-556
 - tell-a-bell, IV-558
 - visual ring indicator, IV-559, IV-561
 - frequency and volume controller, II-623
 - hands-free telephone, III-605
 - handset encoder, I-634, III-613
 - helper/simulator, VI-627
 - hold button, II-628, III-612
 - hold circuit, V-614, VI-624, VI-628
 - in-use indicator, II-629, IV-560, IV-563, V-602
 - intercom, IV-557, V-239, V-240
 - interface
 - audio, V-612, VI-625
 - FCC Part 68, V-613
 - for phone-line, V-605
 - light for, II-625
 - line interface, autopatch, I-635
 - line monitor, I-628
 - line simulator, VI-627
 - line tester, V-615, VI-620
 - message-taker, IV-563
 - monitors, I-625, II-626
 - musical hold, II-623, V-601, V-605
 - musical ringer, II-619
 - night light, telephone controlled, III-604
 - off-hook indicator, I-633
 - optoisolator status monitor, I-626
 - pager, V-609, V-611
 - parallel connection, III-611
 - personal message recorder, V-330-331
 - piezoelectric ringer, I-636
 - power switch, ac, IV-550
 - preamp, transistor RIAA for magnetic cartridges, VI-76
 - pulse-dialing, III-610
 - recording calls, I-632, III-616, IV-553, IV-558, V-600, VI-626
 - redial, III-606
 - relay, I-631
 - remote monitor for, II-626
 - repeater, III-607
 - repertory dialer, line powered, I-633
 - ring amplifier, VI-624, VI-626
 - ring converter, V-602
 - ring detectors, II-623, III-611, III-619, IV-564, VI-628
 - ring indicator, V-604
 - ringers, IV-556, V-600
 - extension-phone ringer, IV-561
 - high-isolation, II-625
 - multi-tone, remote programmable, II-634
 - musical, II-619
 - piezoelectric, I-636
 - plug-in, remote, II-627
 - relay, III-606
 - remote, II-627, III-614, IV-562
 - tone, I-627, I-628, II-630, II-631
 - scrambler, II-618, V-608, VI-623
 - series connection, III-609
 - silencer, IV-557
 - sound level meter monitor, III-614

speaker amplifier, IV-555
 speakerphone, II-632, III-608
 speakerphone adapter, V-606-607
 speech activity detector, II-617, III-615
 speech network, II-633
 status monitor using optoisolator, I-626
 switch, solid-state, line-activated, III-617
 tap, III-622
 tape-recorder starter controlled by, I-632
 telecom converter -48 to +5 V at 1 A, V-472
 timer, tele-timer, V-623
 toll-totalizer, IV-551
 tone-dialing, III-607
 tone ringers, I-627, I-628, II-630, II-631
 Touchtone generator, III-609
 touch-tone decoder, IV-555
 vocalizer, dialed-phone number, III-731
 voice-mail alert, V-607
 teleprinter loop supply, VI-497
 television (*see* amateur television; video circuits)
 temperature-related circuits (*see also* thermometers), I-641-643, I-648, I-657, II-645, III-629-631, IV-565-572, V-616-620, VI-629-647
 0-50 C, four-channel temperature, I-648
 A/D converter for temperature measurement, VI-234-235, VI-634
 absolute temperature log with RS-232, VI-636
 alarms, II-4, II-643, II-644, V-9
 amplifier, precision RTD, for +5 V, VI-643
 automotive water-temperature gauge, II-56, IV-44, IV-48
 body-heat detector, VI-266
 boiler temperature control, I-638
 compensation adjuster, V-617
 control circuits, I-641-643, II-636-644, III-623-628, IV-567, VI-631, VI-641, VI-646
 defrost cycle, IV-566
 heater element, II-642
 heater protector, servo-sensed, III-624
 heat sniffer, electronic, III-627
 liquid-level monitor, II-643
 low-power, zero-voltage switch, II-640
 piezoelectric fan-based, III-627
 proportional, III-626
 signal conditioners, II-639
 single setpoint, I-641
 thermocoupled, IV-567
 zero-point switching, III-624
 converters
 logarithmic, V-127
 temperature-to-digital, V-123
 temperature-to-frequency, I-168, I-646, I-656, II-651-653, V-121
 temperature-to-time, III-632-633
 cool-down circuit for amplifiers, V-354, V-357
 defrost cycle and control, IV-566
 differential temperature, I-654, I-655, VI-645
 flame temperature, III-313
 freeze-up sensor, VI-647
 furnace fuel miser, V-328-329
 heater control, I-639, I-640, II-642, III-624, VI-632
 heat sniffer, III-627
 hi/lo sensor, II-650
 hook sensor on 4- to 20-mA loop, V-618
 IC temperature, I-649
 indicator, II-56, IV-570
 isolated temperature, I-651
 LCD contrast temperature compensator, VI-195
 logarithmic converter, V-127
 low-temperature sensor, V-619
 measuring circuit/sensors, II-653, IV-572
 meters/monitors, I-647, III-206, IV-569
 op amp, temp-compensated breakpoint, V-401
 oscillators, temperature-controlled, I-187, II-427, III-137
 over-temperature switch, IV-571
 over/under sensor, dual output, II-646
 proportional temperature controller, VI-633
 pyrometer, optoelectronic, VI-640
 regulator, zero-voltage switching, VI-647
 remote sensors, I-649, I-654, V-619
 room temperature display, bar graph, VI-641
 sensors, I-648, I-657, II-645-650, III-629-631, IV-568-572, V-619
 -50 to 300 F, single supply, VI-638
 0-50-degree C four channel, I-648
 0-63 degrees C, III-631
 5 V powered linearized platinum RTD signal conditioner, II-650
 automotive-temperature indicator, PTC thermistor, II-56
 Centigrade thermometer, II-648
 coefficient resistor, positive, I-657
 differential, I-654, I-655
 full-range Fahrenheit, VI-643
 output referenced to ground, two-wire, VI-638
 over/under, dual output, II-646
 DVM interface, II-647
 hi/lo, II-650
 integrated circuit, I-649
 isolated, I-651, III-631
 low-temperature, V-619
 remote, I-649, I-654, V-619, VI-638
 soil heater for plants, V-333
 soldering iron control, V-327
 thermal monitor, IV-569
 thermocouple amplifier, cold junction compensation, II-649
 thermocouple multiplex system, III 630
 zero-crossing detector, I-733
 signal conditioners, II-639
 single-setpoint, temperature, I-641
 temperature-to-digital converter, V-123, VI-646
 temperature-to-frequency converter, I-168, I-646, I-656, II-651-653, V-121, VI-639
 temperature-to-time converters, III-632-633
 thermocouples
 amplifier, cold junction compensation, II-649, VI-635, VI-642, VI-644
 control, IV-567
 multiplex system, III-630
 thermometers (*see* thermometers)
 thermostat (*see* thermostats)
 thermostatic fan switch, V-68
 thermostatic relay circuit, VI-643, VI-645
 transconductor, I-646, I-649
 under-temperature switch, IV-570
 zero-crossing detector, I-733
 temperature-to-frequency converter, I-168, I-656, II-651-653, VI-639
 temperature-to-frequency transconductor, linear, I-646
 temperature-to-time converters, III-632-633
 ten-band graphic equalizer, active filter, II-684
 Tesla coils, III-634-636
 test bench amplifier, V-26
 test circuits (*see* measurement/test circuits)
 text adder, composite-video signal, III-716
 thermocouls, II-654-656
 digital, II-656
 electronic, II-655
 thermal flowmeter, low-rate flow, III-203
 thermocouples, II-649, VI-635, VI-642, VI-644
 amplifiers, I-355, I-654, II-14, II-649
 digital thermometer using, II-658
 multiplex, temperature sensor system, III-630
 pre-amp using, III-283
 thermometers (*see also* temperature-related circuits), II-657-662, III-637-643, IV-573-577
 0-50 degree F, I-656
 0-100 degree C, I-656
 1.5-V, VI-637
 5-V operation, V-617
 adapter, III-642
 add-on for DMM digital voltmeter, III-640
 centigrade, I-655, II-648, II-662
 calibrated, I-650
 ground-referred, I-657
 differential, I-652, II-661, III-638, VI-640
 digital, I-651, I-658, V-618, VI-637
 temperature-reporting, III-638
 thermocouple, II-658
 μ P controlled, I-650
 electronic, II-660, III-639, IV-575, IV-576
 Fahrenheit, I-658
 ground-referred, I-656
 high-accuracy design, IV-577
 implantable/ingestible, III-641
 Kelvin, I-653, I-655, II-661
 linear, III-642, IV-574
 low-power, I-655
 meter, trimmed output, I-655
 remote, II-659
 single-dc supply, IV-575
 variable offset, I-652
 thermostats, I-639, I-640, V-60, VI-630
 third-overtone oscillator, I-186, IV-123
 three-in-one test set, III-330
 three-minute timer, III-654
 three-rail power supply, III-466

threshold detectors, precision, III-157
 tilt meter, II-663-666, III-644-646
 differential capacitance
 measurement circuit, II-665
 mercury-switch, V-302
 sense-of-slope, II-664
 ultra-simple level, II-666
 time bases
 crystal oscillator, III-133, IV-128, V-137, V-139
 function generators, 1 Hz,
 readout/counter applications, IV-201
 oscilloscopes timebase generator,
 V-425
 trigger selector for oscilloscopes
 timebase, V-425
 time constants, operational
 amplifiers, RC time constants, VI-426
 time delays, I-668, II-220, II-667-670,
 III-647-649
 circuit, precision solid state, I-664
 constant current charging, II-668
 electronic, III-648
 generator, I-218
 hour sampling circuit, II-668
 integrator to multiply 555 timers,
 low-cost, II-669
 long-duration, I-220
 motor controller, VI-413
 relay, I-219, I-663
 timing threshold and load driver, II-670, III-648
 time division multiplex stereo
 decoder, II-168
 timers (*see also* 555 timer circuits),
 I-666, I-668, II-671-681, III-650-
 655, IV-578-586, V-621-627, VI-
 648-650
 0.1 to 90 second, I-663
 2- to 2000-minute, V-624
 555-based alarm, V-11
 741 timer, I-667
 ac line/timer interface, VI-281
 adjustable, II-681, IV-585
 alarm, II-674, VI-649
 appliance-cutoff timer, IV-583
 CMOS, programmable precision, III-
 652
 countdown, V-627
 darkroom, I-480, V-436
 elapsed time/counter timer, II-680
 electronic egg, I-665
 enlarger timer, II-446, III-445
 extended on-time, V-627
 IC, crystal-stabilized, II-151
 interval, programmable, I-660, II-
 678
 lamp timer, VI-649
 long-delay, I-219, V-626
 long-duration, II-675, IV-585
 long-interval, I-667, IV-581, IV-582
 long-period, V-624, VI-650
 long-term, II-672, III-653
 mains-powered, IV-579
 minute marker, VI-337
 mobile radio on-alarm timer, VI-32
 one-shot, II-266, III-317, III-654
 photographic, I-485
 darkroom enlarger, III-445
 photo-event timer, IV-379
 reaction timer, game circuit, IV-204
 reflex timer, V-622
 SCR design, IV-583
 self-retriggering timed-on
 generator, V-343
 sequential, I-661-662, I-663, III-651,
 V-623
 slide-show, III-444, III-448
 solid-state, industrial applications,
 I-664
 tele-timer, V-623
 ten-minute ID timer, IV-584
 three-minute, III-654
 three-stage sequential, V-623
 thumbwheel-type, programmable
 interval, I-660
 time-out circuit, IV-580, IV-586
 triangle-wave generator, linear, III-
 222
 variable duty-cycle output, III-240
 voltage-controlled, programmable,
 II-676
 washer, I-668
 watch tick timer, V-292
 watchdog timer/alarm, IV-584
 wide-range, V-1-minute to 400
 hours, V-625
 timing light, ignition, II-60
 timing threshold and load driver, III-
 648
 tone alert decoder, I-213
 tone annunciator, transformerless,
 III-27-28
 tone burst generators, I-604, II-90,
 III-74
 tone circuits (*see* function
 generators; sound generators)
 tone controls (*see also* sound
 generators), I-677, II-682-689, III-
 656-660, IV-587-589, V-334, V-
 630-631, VI-651-653
 500-Hz, III-154
 active control, IV-588
 amateur radio amplifier controls,
 1.2-kW 144-MHz, VI-19
 audio amplifier, II-686
 automatic level control (ALC), V-
 60-62
 bass, I-670, V-584, V-631, VI-652
 bass and treble, I-674, V-631, VI-
 653
 Baxandall tone-control audio
 amplifier, IV-588
 decibel level detectors, III-154
 equalizers, II-684, III-658
 filter circuit, V-1 kHz, V-191
 guitar treble booster, II-683
 high-quality, I-675
 high-z input, hi fi, I-676
 level meters, sound levels, III-346,
 III-614, IV-305, IV-307
 loudness, II-46
 microphone preamp, I-675, II-687
 mixer preamp, I-58
 passive circuit, II-689
 preamplifiers, I-58, I-673, I-675, II-
 687, II-688, III-657
 rattle/scratch filter, III-660
 stereo level display circuit, VI-190
 stereo preamp with tone control, V-
 581
 three-band active, I-676, III-658
 three-channel, I-672
 tone detector, 15-kHz, VI-181
 treble control, V-631, VI-652
 tremolo circuit, IV-589
 volume limiter, V-59, VI-376
 Wien-bridge filter, III-659
 tone decoders, I-231, III-143, VI-170
 dual time constant, II-166
 24 percent bandwidth, I-215
 relay output, I-213
 tone-dial decoder, I-630, I-631
 tone detectors, 500-Hz, III-154
 tone-dial generator, I-629
 tone-dialing telephone, III-607
 tone encoder, I-67
 subaudible, I-23
 tone-dial encoder, I-629
 two-wire, II-364
 tone generators (*see* sound
 generators)
 tone probe, digital IC testing with, II-
 504
 tone ringer, telephone, II-630, II-631
 totem-pole driver, bootstrapping, III-
 175
 touch switches, I-131, I-135-136, I-
 137, II-690-693, III-661-665, IV-
 590-594, V-632-635, VI-654-657
 CMOS, I-137
 bistable multivibrator, touch-
 triggered, I-133
 bridging touch plate sensor, V-634
 capacitive sensor touch switch
 system, VI-656
 dimmer, CMOS based, V-270
 double-button latching, I-138
 hum-detecting touch sensor, IV-
 594
 lamp control, three-way, IV-247
 low-current, I-132
 On/Off, II-691, III-663, IV-593
 latching switch, V-635
 line-hum, III-664
 momentary operation, I-133
 negative-triggered, III-662
 on-only switch, V-635
 positive-triggered, III-662
 sensor switch and clock, IV-591
 single-plate sensor, V-633
 switch, V-633, V-634, V-635
 time-on touch switch, IV-594
 tined touch switch, VI-655
 touchomatic, II-693
 two-terminal, III-663
 Touchtone generator, telephone, III-
 609
 toxic gas detector, II-280
 toy siren, II-575
 TR circuit, II-532
 TR switch for antennas, automatic, V-
 37
 tracers, VI-658-659
 audio reference signal, probe, I-527
 bug, III-358
 cable tracer, VI-659
 closed-loop, III-356
 receiver, III-357
 signal tracer, VI-659
 wire tracer, VI-659
 track-and-hold circuits, III-667, III-
 668
 sample-and-hold circuit, III-549, III-
 552
 tracking circuits, III-666-668
 positive/negative voltage reference,
 III-667
 preregulator, III-492
 track-and-hold, III-667, III-668
 tracking power supply, VI-485
 train chuffer sound effect, II-588
 transceivers (*see also* receivers;
 transmitters), IV-595-603
 1750-meter, V-646
 CE, 20-m, IV-596-598

- CW, 5 W, 80-meter, IV-602
 external microphone circuit, V-351
 hand-held, III-39, III-461
 HF transceiver/mixer, IV-457
 memory backup, VI-28
 power supply for lab source, VI-517
 T/R switch, VI-610
 ultrasonic, III-702, III-704
 transducer amplifiers, I-86, III-669-673
 flat-response, tape, III-673
 NAB preamp, III-673
 photodiode amplifier, III-672
 preamp, magnetic phono, III-671, III-673
 tape playback, III-672
 voltage, differential-to-single-ended, III-670
 transducers, I-86
 bridge type, amplifier, II-84, III-71
 detector, magnetic transducer, I-233
 interfacing resistive transducers, VI-281
 sonar, switch and, III-703
 temperature, remote sensor, I-649
 transformers
 isolation transformer, V-349, V-470
 power tester, VI-354
 transistors and transistorized circuits
 flashers, II-236, III-200
 frequency tripler, nonselective, saturated, II-252
 headphone amplifier, II-43
 on/off switch for op amp, IV-546
 phototransistor, V-279
 amplifier, V-409
 variable-sensitivity, V-409
 pulse generator, IV-437
 sorter, I-401
 tester, I-401, IV-281, V-306
 turn-on circuit, V-345
 transistor-matching circuit, VI-339
 transmission indicator, II-211
 transmitters (see also receivers; transceivers), III-674-691, IV-595-603, V-636-649, VI-660-665
 2-meter, IV-600-601
 10-meter DSB, V-647
 27.125-MHz NBFM, V-637
 acoustic-sound transmitter, IV-311
 amateur radio, 80-M, III-675
 amateur TV, IV-599, VI-34-36
 ATV JR transmitter, V-440 MHz, V-640
 audio, visible-light, V-261
 automobile security system, VI-9
 baby-alert, carrier-current circuit, V-95
 beacon, III-683, IV-603
 broadcast, 1-to-2 MHz, I-680
 carrier current, I-144, I-145, III-79
 computer circuit, 1-of-8 channel, III-100
 CW transmitters, I-681, III-684, III-686, III-687, III-690, IV-601, V-648, V-649, VI-22-23, VI-27, VI-664
 DSB, 10-meter, V-647
 dummy load for transmitter tests, VI-37
 fiberoptic, III-177, VI-207
 FM transmitters, I-681, V-641
 27.125-MHz NBFM, V-637
 49-MHz, V-643
 bug, VI-662
 infrared, voice-modulated pulse, IV-228
 light-beam, V-259
 multiplex, III-688
 one-transistor design, III-687
 optical, I-361, I-367, II-417
 radio, V-648
 snooper, III-680
 stereo, V-575, V-580, VI-662
 voice, III-678
 wireless microphone, III-682, III-685, III-691
 half-duplex information
 transmission link, low-cost, III-679
 HF, low-power, IV-598
 infrared, I-342, I-343, II-289, II-290, III-275, III-277, IV-226-227, IV-228
 audio-modulated, VI-262
 headphones, V-227
 pulsed for on/off control, V-228
 pulse frequency modulated, VI-269
 single-tone, VI-264
 steady-tone, VI-267
 wireless headphones, VI-263
 keyer interface circuit, amateur radio, VI-31
 laser diode-based, VI-292
 LED lightwave communications, VI-309
 line-carrier, with on/off, 200 kHz, I-142
 low-frequency, III-682
 MIDI transmitter, V-393
 memory backup, VI-28
 modulated-light transmitter, V-258
 Morse code transmitter, V-6-W for 7-MHz, V-641
 multiplexed, 1-of-8 channel, III-395
 negative key-line keyer, IV-244
 optical, I-361, I-363, II-417, II-418, IV-368
 oscillator and, 27 and 49 MHz, I-680
 output indicator, IV-218
 photodiode log
 converter/transmitter, VI-312
 QRP, V-638-639, V-644-645
 remote control, V-509, V-513
 interface, V-511
 ultrasonic, V-512
 remote sensors, loop-type, III-70
 television, III-676
 tracking transmitter, V-642
 transceiver, 1750-meter, V-646
 transceiver T/R switch, VI-610
 transmit/receive sequencer, preamp, V-348
 ultrasonic
 40 kHz, I-685
 CW transceiver, VI-669
 Doppler, V-651
 vacuum-tube, low-power, 80/40-M, V-642
 voice-communication, light-beam, V-260
 VHF, III-681, III-684, VI-663
 video detector for transmitter tests, VI-37
 wireless guitar transmitter, VI-661
 wireless microphone, VI-661
 transverter, 2-to-6 meter, V-124
 treasure locator, lo-parts, I-409
 treble booster, guitar, II-683
 tremolo circuits, I-59, I-598, III-692-695, IV-589
 tri-color indicator, V-232
 triac circuits, V-268
 ac-voltage controller, IV-426
 contact protection, II-531
 controller circuit, V-267, V-271
 dimmer switches, I-375, II-310, III-303
 drive interface, direct dc, I-266
 microcomputer-to-triac interface, V-244
 microprocessor array, II-410
 relay-contact protection with, II-531
 switch, inductive load, IV-253
 trigger, I-421
 voltage doubler, III-468
 zero point switch, II-311
 zero voltage, I-623
 triangle-to-sine converter, II-127
 triangle/square wave oscillator, II-422, V-206
 triangle-wave generators, III-234, V-203, VI-596, VI-697, VI-698
 10-Hz to 10-kHz VCO, V-570
 clock-driven, V-206
 square/triangle-wave, III-225, III-239, III-242
 timer, linear, III-222
 triangle-wave oscillator, V-205
 trickle charger, 12 V battery, I-117
 triggers
 50-MHz, III-364
 camera alarm, III-444
 flash, photography, xenon flash, III-447
 load-sensing, V-285
 optical Schmitt, I-362
 oscilloscope-triggered sweep, III-438
 remote flash, I-484
 SCR series, optically coupled, III-411
 sound/light flash, I-482
 triac, I-421
 triggered sweep, add-on, I-472
 tripler, nonselective, transistor saturation, II-252
 trouble tone alert, II-3
 TTL circuits
 clock, wide-frequency, III-85
 coupler, optical, III-416
 gates, siren using, II-576
 Morse code keyer, II-25
 oscillator, VI-437
 speaker driver, VI-199
 square-to-triangle wave converter, II-125
 TTL-to-MOS logic converter, II-125
 TTL oscillators, I-179, I-613, IV-127
 1 MHz to 10 MHz, I-178
 1 MHz to 20 MHz, IV-127
 crystal, TTL-compatible, I-179
 sine wave/square oscillator, IV-512
 television display using, II-372
 tube amplifier, high-voltage isolation, IV-426
 tuners
 antenna tuner, IV-14, V-38, VI-66
 FM, I-231
 guitar and bass, II-362
 turbo circuits, glitch free, III-186
 turn-on circuit, V-345
 twang-twang circuit, II-592
 twilight-triggered circuit, II-322
 twin-T notch filters, III-403

Twenty-One game, VI-246
two state siren, III-567
two-tone generator, II-570
two-tone siren, III-562
two-way intercom, III-292
two's complement, D/A conversion system, binary, 12-bit, III-166

U

UA2240 staircase generator, III-587
UHF-related circuits (*see also* radio/rf circuits)
antenna for UHF scanners, VI-67
amplifier, I-560-565
audio-to-UHF preamp, V-24
broadband rf amplifiers, V-523
field-strength meters, IV-165
oscillator, tunable, VI-456
rf amplifiers, UHF TV-line amplifier, IV-482, IV-483
source dipper, IV-299
TV preamplifier, III-546
VHF/UHF rf diode switch, IV-544
VHF/UHF rf preamplifier, V-515
wideband amplifier, I-560, III-264
UJT circuits
battery chargers, III-56
calibration oscillator, 100-kHz, VI-157
metronome, II-355
monostable circuit, bias voltage change insensitive, II-268
ultrasonic circuits (*see also* sound-operated circuits), III-696-707, IV-604-606, V-650-653, VI-666-670
arc welding inverter, 20 kHz, III-700
cleaner, V-652-653
CW transceiver, VI-669
generator, VI-670
induction heater, 120-kHz 500-W, III-704
motion detector, VI-668
pest-control/repel, I-684, II-685, III-699, III-706, III-707, IV-605-606
proximity sensor, VI-669
ranging system, III-697
receiver, III-698, III-705, VI-670
Doppler ultrasound, V-651
remote-control receiver, V-513
remote-control tester, VI-667
remote-control transmitter, V-512
sonar transducer/switch, III-703
sound source, IV-605
switch, I-683
transceiver, III-702, III-704
transmitter, I-685
Doppler ultrasound, V-651
undervoltage detector/monitor, III-762, IV-138, VI-117
uninterruptible power supply, II-462, III-477, V-471
unity-gain amplifiers
inverting, I-35, I-80
noninverting, V-21, V-22
ultra high-Z, ac, II-7
unity-gain buffer
stable, speed and high-input impedance, II-6
unity-gain follower, I-27
universal counters
10 MHz, I-255, II-139
40-MHz, III-127
universal mixer stage, III-370
universal power supply, 3-30V, III-489

up/down counters
8 digit, II-134
extreme count freezer, III-125
XOR gate, III-105

V

vacuum fluorescent display circuit, II-185
vacuum gauge, automotive, IV-45
vacuum tube amplifier, VI-72-73, VI-87
vapor detector, II-279
varactor-tuned 10 MHz ceramic resonator oscillator, II-141
variable current source, 100 mA to 2A, II-471
variable-frequency inverter, complementary output, III-297
variable-frequency oscillators (VFO)
5 MHz design, II-551
4093 CMOS, V-421
adjustable temperature compensation, V-420
amateur radio, V-532
buffer amplifier, V-92
CMOS design, V-418
code practice oscillators, V-103
rf, V-6.5 MHz, V-529
variable-gain amplifier, voltage-controlled, I-28-29
variable-gain and sign op amp, II-405
variable-gain circuit, accurate null, III-69
variable-state filters
universal, V-178
variable oscillators, II-421
audio, 20 Hz to 20 kHz, II-727
duty-cycle, III-422
four-decade, single control, II-424
sine-wave oscillator, low-distortion, III-558
wide range, II-429
variable power supplies, III-487-492, IV-414-421
0- to 12-V, V-1 A, V-460
current source, voltage-programmable, IV-420
dc supply
SCR variable, IV-418
step variable, IV-418
dual universal supply, 0-to-50 V, 5 A, IV-416-417
regulated supply, 2.5 A, 1.25-to-25 V
switch-selected fixed-voltage supply, IV-419
switching regulator, low-power, III-490
switching, 100-kHz multiple-output, III-488
tracking preregulator, III-492
transformerless supply, IV-420
universal 3-30V, III-489
voltage regulators for variable supplies, III-490, III-492, IV-421
variable current source, 100mA to 2A, II-471
voltage regulator, III-491
VCR/TV circuits
ISD 1000A record/playback circuit, VI-50
on/off control, V-113
tester for VCR head amplifier, VI-48
video detector controller, VI-178
vehicles (*see* automotive circuits)
vertical deflection circuit, VI-374
VHF-related circuits (*see also* radio/rf; television: UHF)
amplifiers, I-558
beacon transmitter, VI-663
crystal oscillators, III-138-140
HF/VHF switchable active antenna, V-524
modulator, I-440, III-684
tone transmitter, III-681
transmitters, III-681, III-684
VHF/UHF diode rf switch, IV-544
VHF/UHF rf preamplifier, V-515
video circuits (*see also* amateur television (ATV)), III-713-728, IV-607-621, V-654-662, VI-671-683
amateur TV (ATV) down converter, V-125, V-126
amplifiers, video, I-688, I-690, I-692, III-39, III-708-712, IV-482, IV-483, V-656, V-662, VI-674, VI-675, VI-679, VI-681, VI-682
75-ohm video pulse, III-711
buffer, low-distortion, III-712
color, I-34, III-724
dc gain-control, III-711
differential video loop-through, V-657
FET cascade, I-691
gain block, III-712
IF, I-689, II-687, V-655
JFET bipolar cascade, I-692
line driving, III-710
log amplifier, I-38
output, V-655
RGB, III-709
summing, clamping circuit and, III-710
TV amplifiers, I-688, I-690, III-39, IV-482, IV-483
variable-gain video loop-through, V-658
amplifier/driver, VI-683
ATV video sampler circuit, V-656
audio/video switcher circuit, IV-540-541
automatic TV turn-off, I-577
buffers, V-93
cable driver, VI-200, VI-678
camera-image tracker, analog voltage, IV-608-609
camera link, wireless, III-718
chroma demodulator with RGB matrix, III-716
coax cable driver, VI-201
color amplifier, III-724
color-bar generator, IV-614
commercial zipper, V-334-335
composite-video signal text adder, III-716
converters
RGB-to-NTSC, IV-611
video a/d and d/a, IV-610-611
cross-hatch generator, color TV, III-724
data interface, TTL oscillator, II-372
dc restorer, III-723, V-659
decoders
NTSC-to-RGB, IV-613
stereo TV, II-167, V-576-579, V-580
video line decoders, VI-171
delayed video trigger for oscilloscopes, VI-464
detectors
IF, MC130/MC1352 design, I-688

low-level video, I-687-689
 transmitter tests, VI-37
 downconverter, VI-40-41, VI-44-45
 differential video loop-through
 amplifier, V-657
 driver, two-input video MUX cable
 driver, VI-197
 dummy load for transmitter tests,
 VI-37
 equalizer, VI-681
 fader, V-658
 filter, VSB filter for LM 2880, VI-219
 gray-scale generator, European line
 standard, VI-680
 gray-scale video generator, NTSC,
 VI-679
 high-performance video switch, III-
 728
 horizontal deflection circuit, VI-382
 IF amplifier, 4.5-MHz sound, V-655,
 VI-678
 IF detector, amplifier,
 MC130/MC1352, I-688
 ISD 1000A record/playback circuit,
 VI-50
 line driver, VI-683
 line pulse extractor, IV-612
 line receiver, VI-550
 line/bar generator, V-662
 loop-thru amplifier, IV-616
 master circuit, video master, V-661
 mixer, high-performance video
 mixer, IV-609
 modulators, I-437, I-439, II-371, II-
 372, II-433, II-434, VI-399, VI-403
 monitors, RGB, blue box, III-99
 monochrome-pattern generator, IV-
 617
 multiplexer, cascaded, I-of-15, III-
 393
 MUX cable driver
 multi input, V-657
 two-input, V-657
 NTSC-to-RGB converter, VI-677
 one-of-two video selector, VI-676
 op amp circuits, IV-615
 output amplifier, V-655
 PAL/NTSC decoder with RGB
 input, III-717
 palette, III-720
 picture fixer/inverter, III-722
 preamplifier, III-546, V-660, VI-37
 remote control, IR relay, VI-263
 rf amplifiers, TV sound system, V-
 519
 rf up-converter for TVRO
 subcarrier reception, IV-501
 RGB-composite converter, III-714
 sampler circuit, ATV video, V-656
 satellite TV audio switcher, IV-543
 selector, V-660
 signal-amplitude measurer, V-309
 signal clamp, III-726
 sound, IF/FM IF amplifier with
 quadrature, I-690
 staircase generator, VI-597
 stereo-sound decoder, II-167
 stereo TV decoder, V-576-579, V-
 580
 summing amplifier, VI-681
 sweep/function generator, VI-238-
 241
 switching circuits, III-719, III-725,
 III-727, IV-618-621, VI-680
 video/audio switch, V-586
 wideband for RGB signals, V-587
 switching power supply for color
 TV, SCR, VI-487
 sync circuits, VI-615-618
 sync separator, III-715, IV-616
 sync stripper/video interface, V-659
 tester for VCR head amplifier, VI-48
 titler, VI-672-674
 transmitter, TV, III-676, IV-599, VI-
 34, VI-35, VI-36, VI-38-39, VI-42-
 43
 TV sound system, rf amplifiers, V-
 519
 twisted-pair video driver/receiver
 circuit, VI-682
 variable-gain video loop-through
 amplifier, V-658
 VCR video detector controller, VI-
 178
 VCR/TV on-off control, V-133
 vertical deflection circuit, VI-374
 video, power, channel-select signal
 carrier, V-344-345
 UHF oscillator, tunable, VI-456
 VHF beacon transmitter, VI-663
 wireless camera link, III-71
 VLF/VHF wideband antenna
 low-noise, active, V-33
 vocal eliminator, IV-19
 voice communications
 light-beam transmitter/receiver, V-
 260
 personal message recorder, V-330-
 331
 voice-mail alert for telephone, V-
 607
 voice scrambler/descrambler, IV-26,
 IV-27
 voice substitute, electronic, III-734
 voice-activated circuits (see also
 sound-operated circuits;
 telephone-related circuits), III-
 729-734, IV-622-624, V-545-555
 ac line-voltage announcer, III-730
 allophone generator, III-733
 amplifier/switch, I-608
 computer speech synthesizer, III-
 732
 dialed phone number vocalizer, III-
 731
 disguiser for voices, V-326-327
 intercoms, V-239, VI-376
 level meter, VI-194
 message system, single-chip, VI-373
 scanner voice squelch, IV-624
 scrambler, V-554
 speech detector, II-617, III-615
 stripper, vocal stripper, V-546-547
 switches, III-580, IV-527
 switch/amplifier, I-608, V-553
 vocal stripper, V-546-547, VI-372,
 VI-373
 voice identifier for amateur radio
 use, V-550
 voice substitute, electronic, III-734
 VOX circuit, IV-623
 voltage bias regulator, VI-519
 voltage-controlled amplifier (VCA), I-
 31, I-598, IV-20, VI-684-685
 attenuator for, II-18
 differential-to-single-ended, III-670
 reference, I-36
 tremolo circuit, I-598
 variable gain, I-28-29
 voltage-controlled oscillators (VCO),
 I-702-704, II-702, III-735, IV-625-
 630, V-663-667, VI-685-687
 3-5 V regulated output converter,
 III-739
 10 Hz to 10 kHz, I-701, III-735-741
 three-decade, V-666
 555-VCO, IV-627
 audio-frequency VCO, IV-626
 basic circuit, V-666, V-667
 crystal oscillator, III-135, IV-124
 current sink, voltage-controlled, IV-
 629
 DDS digital, VI-447
 driver, op-amp design, IV-362
 linear, I-701, IV-628
 triangle/square wave, II-263
 logarithmic sweep, III-738
 one-shot, II-266
 precision, I-702, III-431
 restricted-range, IV-627
 sine-wave oscillator, V-666
 sinusoidal 3-Hz to 300-kHz, V-664-
 665
 stable, IV-372-373
 square-wave generators, V-570
 supply voltage splitter, III-738
 three-decade, I-703
 -based, V-665
 CMOS, balanced, III-736
 two-decade, high-frequency, I-704
 varactorless, IV-630
 variable-capacitance diode-sparked,
 III-737
 VHF oscillator, voltage-tuned, IV-
 628
 waveform generator, III-737
 wide-range, IV-627, IV-629
 voltage-controller, pulse generator,
 III-524
 voltage converters/inverters, III-742-
 748, V-668-669
 12-to-16 V, III-747
 dc-to-ac inverter, V-669
 dc-to-dc, III-744, III-746, V-669
 flyback, high-efficiency, III-744
 flyback-switching, self-oscillating,
 III-748
 negative voltage, μP -controlled, IV-
 117
 offline, 1.5-W, III-746
 regulated 15-V_{out} 6-V driven, III-745
 splitter, III-743
 unipolar-to-dual supply, III-743
 voltage-to-current converters, I-
 163, I-166, II-124, III-110, III-120,
 IV-118, VI-153
 voltage-to-frequency converters, I-
 707, III-749-757, IV-638-642
 1 Hz-to-10 MHz, III-754
 1 Hz-to-30 MHz, III-750
 1 Hz-to-1.25 MHz, III-755
 5 kHz-to-2 MHz, III-752
 10 Hz to 10 kHz, I-706, III-110
 accurate, III-756
 differential-input, III-750
 function generators,
 potentiometer-position, IV-200
 low-cost, III-751
 low-frequency converter, IV-641
 negative input, I-708
 optocoupler, IV-642
 positive input, I-707
 precision, II-131
 preserved input, III-753
 ultraprecision, I-708
 wide-range, III-751, III-752
 voltage-to-pulse duration converter,
 II-124

voltage converters/inverters, *continued*
 voltage-ratio-to-frequency converter, III-116

voltage detector
 glitch detector, VI-178
 grid leak detector, VI-179

voltage detector relay, battery charger, II-76

voltage doublers, III-459, IV-635, V-460
 cascaded, Cockcroft-Walton, IV-635
 triac-controlled, III-468

voltage followers, I-40, III-212, VI-127, VI-386
 fast, I-34
 noninverting, I-33
 signal-supply operation, amplifier, III-20

voltage inverters, precision, III-298

voltage indicators/meters (*see also* voltmeters), III-758-772, IV-423, VI-688-695
 amplifiers, VI-689, VI-695
 audible voltage indicator, VI-694
 automotive battery voltage gauge, IV-47
 battery-voltage measuring regulator, IV-77
 calibrator, VI-693
 comparator and, II-104
 dc meter, expanded scale, VI-692
 five-step level detector, I-337
 frequency counter, III-768
 HTS, precision, I-122
 level detectors, I-338, II-172, III-759, III-770
 low-voltage indicator, III-769
 monitor, V-315, VI-689, VI-694
 multiplexed common-cathode LED ADC, III-764
 over/under monitor, III-762
 peak program detector, III-771
 solid-state battery, I-120
 ten-step level detector, I-335
 visible, I-338, III-772
 voltage freezer, III-763
 voltage-level circuit, V-301

voltage multipliers, IV-631-637, V-670-672
 2,000 V low-current supply, IV-636-637
 10,000 V dc supply, IV-633
 corona wind generator, IV-633
 doublers, III-459, IV-635
 cascaded, Cockcroft-Walton, IV-635
 dc, V-672
 triac-controlled, III-468
 high-voltage tripler, VI-504
 laser power supply, IV-636
 low-frequency multiplier, IV-325
 negative-ion generator, high-voltage, IV-634
 quadrupler, dc, V-671
 tripler, IV-637, V-671, VI-504, VI-531

voltage probes, V-474

voltage references, III-773-775
 bipolar source, III-774
 digitally controlled, III-775
 expanded-scale analog meter, III-774
 positive/negative, tracker for, III-667
 variable-voltage reference source, IV-327

voltage regulators, I-501, I-511, II-484, III-485, VI-482, VI-486, VI-561-567
 0- to 10-V at 3A, adjustable, I-511
 0- to 22-V, I-510
 0- to 30-V, I-510
 3 A, III-472
 3.3-V adjustable, VI-489
 4- to 70-V, VI-493
 5 V, low-dropout, III-461
 5 V, 1 A, I-500
 5 V, ultrastable reference, I-497
 6 A, variable output switching, I-513
 8- from 5-V regulator, V-469
 10 A, I-510
 10 A, adjustable, III-492
 10 V, high-stability, III-468
 15 V, 1 A, remote sense, I-499
 15 V, slow-turn-on, III-477
 -15 V negative, I-499
 45 V, 1 A switching, I-499
 90 V rms voltage regulator with PUT, II-479
 100 Vrms, I-496
 200 kHz, I-491
 200-V, VI-505
 ac, III-477
 adjustable output, I-506, I-512
 application circuit, I-492
 automotive circuits, III-48, IV-67
 battery power suppliers, I-117, IV-77
 bilateral source/load power system, VI-488
 bucking, high-voltage, III-481
 combination voltage/current regulator, V-455
 common hot-lead regulator, IV-467
 constant voltage/constant current, I-508
 current and thermal protection, 10 amp, II-474
 Darlington, IV-421
 dual-tracking, III-462
 efficiency-improving switching, IV-464
 fixed pnp, zener diode increases output, II-484
 fixed-current regulator, IV-467
 fixed supplies, III-461, III-468, III-471-477, IV-408, IV-462-467
 flyback, off-line, II-481
 foldback-current limiting, II-478
 high- or low-input regulator, IV-466
 high-stability, I-499, I-502, III-468
 high-voltage power supplies, I-509, II-478, III-485, III-490, VI-500, VI-503
 IC regulator protector, VI-483
 inductorless, III-476
 junk transistors, VI-497
 LM317 design, IV-466
 loss cutter, V-467
 low-dropout, 5-V, III-461, VI-486
 low-power, I-695, III-490
 low-voltage, I-502, I-511
 linear, II-468, III-459
 mobile, I-498
 MPU, multiple output, I-513
 multiple on-card adjuster, VI-494
 negative, I-498, I-499, III-474, IV-465
 npn/pnp boost, III-475
 off-line flyback regulator, II-481
 pnp, II-484

positive, I-498, III-471, III-475, VI-491, VI-518
 pre-regulators, II-482, III-480, III-492
 programmable, IV-470
 projection lamp, II-305
 PUT, 90 V rms, II-479
 radiation-hardened 125A linear regulator, II-468
 remote shutdown, I-510
 SCR preregulator for, II-482
 single supply voltage regulator, II-471
 sensor, LM317 regulator sensing, IV-466
 short-circuit protection, low-voltage, I-502
 single-ended, I-493
 single-supply, II-471
 slow-turn-on 15 V, I-499
 step-down, I-493
 step-up, II-78
 switching supplies, I-491, I-492, I-493, I-497, I-498, I-513, II-73, III-472, III-476, III-490, IV-408, IV-463, V-453, VI-484
 3-A, III-472
 3 W, application circuit, I-492
 5 V, 6 A 25 kHz, separate ultrastable reference, I-497
 6 A, variable output, I-513
 200 kHz, I-491
 high-current inductorless, III-476
 low-power, III-490
 multiple output, for use with MPU, I-513
 step down, I-493
 variable current source with voltage regulation, IV-470
 variable supplies, III-490, III-491, III-492, IV-421, IV-468-470
 crowbar limiting, VI-515
 current limiting, VI-518
 current source, III-490
 zener design, programmable, IV-470

voltage sources
 millivolt, zenerless, I-696
 programmable, I-694
 pseudorandom, VI-381
 voltage splitter, III-738

voltmeters, III-758
 3.5 digit, I-710
 full scale, III-761
 true rms ac, I-713
 4.5-digit, III-760
 5-digit, III-760
 ac, III-765, VI-690-691
 wide-band, I-716
 wide-range, III-772
 add-on thermometer for, III-640
 bar-graph, I-99, II-54
 dc, III-763, VI-692
 high-input resistance, III-762
 low-drift, V-301

digital voltmeters (DVM), III-4, VI-593, VI-329
 3.5-digit, common anode display, I-713
 3.5-digit, full-scale, four-decade, III-761
 3.75-digit, I-711
 4.5-digit, III-760
 4.5-digit, LCD display, I-717
 auto-calibrate circuit, I-714
 automatic nulling, I-712
 interface and temperature sensor, II-647

LED readout, IV-286
 temperature sensor and DVM, 647
 FET, I-714, III-765, III-770
 high-input resistance, III-768
 JFET, V-318
 LED expanded scale, V-311
 millivoltmeters, III-767, III-769, IV-289, IV-294, IV-295
 ac, I-716
 audio, III-767, III-769
 dc, IV-295
 four-range, IV-289
 high-input impedance, I-715
 LED readout, IV-294
 rf, I-405, III-766
 voltmeters (VOM)
 field strength, I-276
 phase meter, digital readout, IV-277
 volume amplifier, II-46
 volume control circuits, IV-643-645
 telephone, II-623
 volume indicator, audio amplifier, IV-212
 volume limiter, audio signal amplifiers, V-59
 VOR signal simulator, IV-273
 voting circuit, noise-based, VI-422-423
 vox box, II-582, IV-623
 Vpp generator, EPROM, II-114
 VU meters, III-487
 extended range, II-487, I-715
 LED display, IV-211

W

waa-waa circuit, II-590
 wailers (see alarms; sirens)
 wake-up call, electronic, II-324
 walkman amplifier, II-456
 warblers (see alarms; sirens)
 warning devices
 auto lights-on warning, II-55
 high-level, I-387
 high-speed, I-101
 light, II-320, III-317
 low-level, audio output, I-391
 speed, I-96
 varying-frequency alarm, II-579
 water-level sensors (see fluid and moisture detectors)
 water-temperature gauge, automotive, IV-44
 wattmeter, I-17, VI-342
 wave-shaping circuits (see also waveform generators), IV-646-651
 capacitor for high-slew rates, IV-650
 clipper, glitch-free, IV-648
 flip-flop, S/R, IV-651
 harmonic generator, IV-649
 phase shifter, IV-647
 rectifier, full-wave, IV-650
 signal conditioner, IV-649
 waveform generators (see also burst generators; function generators; sound generators; square-wave generators; wave-shaping circuits), II-269, II-272, V-200-207, VI-696-702
 AM broadcast-band, IV-302
 AM/FM, 455 kHz, IV-301
 audio, precision, III-230
 four-output, III-223
 harmonic generators, I-24, III-228, IV-649

high-frequency, II-150
 high-speed generator, I-723
 monostable multivibrator, VI-700
 pattern generator/polar-to-rect. converter, V-288
 precis, II-274
 pulse generator, VI-699
 PWM signal generator, VI-698
 ramp generators, I-540, II-521-523, III-525-527, IV-443-447
 555 based, V-203
 accurate, III-526
 integrator, initial condition reset, III-527
 linear, II-270
 variable reset level, II-267
 voltage-controlled, II-523
 sawtooth generator, III-241, IV-444, IV-446, V-204, V-205, V-491, VI-575-577, VI-701
 signal source for audio amplifier/inverter, VI-702
 sine-wave generators, IV-505, IV-506, V-541, V-542, V-543, V-544, VI-701
 60 Hz, IV-507
 audio, II-564
 LC, IV-507
 LF, IV-512
 oscillator, audio, III-559
 square-wave and, tunable oscillator, III-232
 VLF audio tone, IV-508
 sine/cosine generator, VI-700
 sine/square wave generators, I-65, III-232, IV-512
 square-wave generators, II-594-600, III-225, III-239, III-242, III-583-585, IV-529-536, V-568-570, VI-593-594
 1 kHz, IV-536
 2 MHz using two TTL gates, II-598
 555 timer, II-595
 astable circuit, IV-534
 astable multivibrator, II-597
 CMOS 555 astable, true rail-to-rail, II-596
 duty-cycle multivibrator, III-50-percent, III-584
 four-decade design, IV-535
 high-current oscillator, III-585
 line frequency, II-599
 low-frequency TTL oscillator, II-595
 multiburst generator, II-88
 multivibrator, IV-536
 oscillators, I-613-614, I-616, II-596, II-597, II-616, IV-532, IV-533
 phase-tracking, three-phase, II-598
 pulse extractor, III-584
 quadrature-outputs oscillator, III-585
 sine-wave and, tunable oscillator, III-232
 three-phase, II-600
 tone-burst generator, single timer IC, II-89
 triangle-wave and, III-225, III-239, III-242
 TTL, LSTTL, CMOS designs, IV-530-532
 variable duty-cycle, IV-533
 variable-frequency, IV-535
 staircase generators, I-730, II-601-602, III-586-588, IV-443, VI-595-599

stepped waveforms, IV-447
 sweep generators, I-472, III-438
 test signal generator, VI-702
 three-phase digital, VI-343
 triangle-wave, III-234, V-203, V-205, V-206, VI-697, VI-698
 stepped, VI-596
 square wave, I-726, III-225, III-239, III-242, V-206
 timer, linear, III-222
 two-function, III-234
 VCO and, III-737
 waveguide circuits, VI-703-704
 wavemeter, tuned RF, IV-302
 weather-alert decoder, IV-140
 weight scale, digital, II-398
 Wheatstone bridge, VI-123, VI-148
 Wheel-of-Fortune game, IV-206, VI-254
 whistle, steam locomotive, II-589, III-568
 who's first game circuit, III-244
 wide-range oscillators, I-69, I-730, III-425
 wide-range peak detectors, III-152
 hybrid, 500 kHz-1 GHz, III-265
 instrumentation, III-281
 miniature, III-265
 UHF amplifiers, high-performance FETs, III-264
 wideband amplifiers
 low-noise/low-drift, I-38
 two-stage, I-689
 rf, IV-489, IV-490, IV-491
 HF, IV-492
 JFET, IV-493
 MOSFET, IV-492
 two-CA3100 op amp design, IV-491
 unity gain inverting, I-35
 wideband signal splitter, III-582
 wideband two-pole high-pass filter, II-215
 Wien-bridge filter, III-659
 notch filter, II-402
 Wien-bridge oscillators, I-62-63, I-66, I-70, II-566, III-429, III-558, IV-371, IV-377, IV-511, V-415, V-419, V-541, VI-439, VI-444
 CMOS chip in, II-568
 low-distortion, thermally stable, III-557
 low-voltage, III-432
 sine wave, I-66, I-70, II-566, IV-510, IV-513
 single-supply, III-558
 thermally stable, III-557
 three-decade, IV-510
 variable, III-424
 very-low-distortion, IV-513
 wind chimes, electronic, VI-591
 wind-powered battery charger, II-70
 winder, I-330
 window circuits, II-106, III-90, III-776-781, IV-655-659, V-673-674
 comparator, IV-656-657, IV-658, IV-659, V-299, V-674
 detector, I-235, III-776-781, IV-658, VI-181
 digital frequency window, III-777
 discriminator, III-781, V-674
 generator, IV-657
 high-input-impedance, II-108
 windshield wiper circuits (see automotive circuits)
 wire tracer, II-343

wireless microphones (*see*
microphones)
wireless speaker system, IR, III-272
wiring
 ac outlet tester, V-318
 ac wiring locator, V-317
 two-way switch, V-591
write amplifiers, III-18
WWV converter, VI-147
WWV receiver, VI-538-539, VI-558

X

xenon flash trigger, slave, III-447
XOR gates, IV-107
 complementary signals generator,
 III-226

oscillator, III-429
up/down counter, III-105

Y

yelp oscillator/siren, II-577, III-562

Z

Z80 clock, II-121
Z-Dice game 248-249, VI-248
zappers, battery, II-64, II-66, II-68
zener diodes
 clipper, fast and symmetrical, IV-
 329
 increasing power rating, I-496, II-
 485

 limiter using one-zener design, IV-
 257
 test set, V-321
 tester, I-400
 variable, I-507
 voltage regulator, programmable,
 IV-470
zero crossing detector, I-732, I-733,
 II-173
zero crossing switch, VI-606
zero meter, suppressed, I-716
zero point switches
 temperature control, III-624
 triac, II-311
zero-voltage switches
 closed contact half-wave, III-412
 solid-state, III-410, III-416

ABOUT THE AUTHORS

Rudolf F. Graf has 45 years of engineering, sales, and marketing experience in the electronics field. He has written more than 30 books (about three million copies printed) and well over 100 articles. He is a senior member of the IEEE, a licensed amateur radio operator (KA2CWL), and has a BSEE degree from Polytechnic Institute of Brooklyn and an MBA from NYU. He is self-employed.

William Sheets is a self-employed circuit design engineer. He has more than 25 years of experience in RF, analog, and digital electronics. He has written numerous articles in electronics publications and co-authored five books with Graf. His interests include amateur radio (K2MQJ), photography, and travel. He has designed and built numerous items, including a satellite TV system, many transmitters and receivers, and a computer. He has an MEE degree from NYU, is married, and lives in up-state New York.